

# Instruction Manual



For sales and service please call:

PTB Sales  
Ph. (626) 334-0500  
Fax (626) 334-2151  
Toll Free 866-332-0500

[www.ptb-sales.com](http://www.ptb-sales.com)

## *BOC Edwards Model HTU-108 Series Heat Exchanger*



**BOC EDWARDS**

One Edwards Park, 301 Ballardvale Street, Wilmington, MA 01887

Telephone: 1 (800) 848-9800 Fax: (978) 658-7969 (General Office)

Fax: (978) 694-1169 (Executive Office)





# CONTENTS

## DECLARATION OF CONFORMITY

<b>1 INTRODUCTION</b> .....	<b>1</b>
1.1 Scope of the manual .....	1
1.2 Description of the HTU .....	1
1.3 Lockout Procedure .....	1
1.4 Safety Features and Interlocks.....	2
1.5 Safety Symbols used in this Manual.....	3
1.6 Principles of Operation .....	5
1.7 Design Concept .....	5
1.7.1 Main Cooling Loop .....	7
1.7.2 Back Pressure Regulator (BPR) By-pass Loop .....	8
1.7.3 De-ionization By-pass Loop .....	8
<b>2 TECHNICAL DATA</b> .....	<b>9</b>
2.1 Storage Conditions .....	9
2.2 Facility Requirements .....	9
2.3 Physical Data .....	9
2.4 Allowable Operating Conditions on 208V/3-phase/60Hz Main Power .....	11
2.5 Allowable Operating Conditions on 200V/3-phase/50Hz Main Power .....	11
2.6 Rated Thermal Performance on 200V/3-phase/50Hz Main Power .....	11
2.7 Rated Performance of Pump on 200V/3-phase/50Hz Main Power .....	11
2.8 Analog Communication Interface Connectors (to be supplied by customer).....	11
2.9 DeviceNet Communication Interface .....	11
<b>3 INSTALLATION AND SETUP</b> .....	<b>12</b>
3.1 Unpacking and Inspection .....	12
3.2 Siting .....	12
3.3 Plumbing Installation.....	13
3.4 Electrical Installation.....	18



<b>4 OPERATION</b> .....	<b>23</b>
4.1 Front Panel Controls .....	23
4.2 Keypad and Liquid Crystal Display (LCD) .....	24
4.2.1 STATUS Menu .....	26
4.2.2 NORMAL Menu .....	27
4.2.3 CONTROL Menu .....	27
4.2.4 SETUP Menu .....	28
4.3 Start-up Procedure .....	29
4.4 Shut Down Procedure .....	29
4.5 AC Power Distribution .....	29
4.6 Microprocessor Controls .....	30
4.7 Host Interface Communications .....	30
4.8 Shut Down Procedure .....	30
4.9 AC Power Distribution .....	30
<b>5 MAINTENANCE</b> .....	<b>31</b>
5.1 Hazard Warnings .....	31
5.2 Electrical Hazards .....	33
5.3 Filling the Reservoir with Coolant .....	33
5.4 Draining/Bleeding the Reservoir .....	34
5.5 De-ionization (DI) Cartridge Replacement .....	35
5.6 Preventative Maintenance Schedule .....	36
5.7 Circuit Breakers and Replaceable Electrical Fuses .....	37
5.8 Troubleshooting .....	38
APPENDIX A-1 SETUP Menu – UNITS Flow Chart.....	41
APPENDIX A-2 SETUP Menu – NORMAL Display Flow Chart .....	42
APPENDIX A-3 SETUP Menu – TRIP POINTS Flow Chart.....	43
APPENDIX A-4 SETUP Menu – Factory Default Parameter Values .....	44
APPENDIX A-5 SETUP Menu – MESSAGES Flow Chart .....	45
APPENDIX B-1 - SCHEMATIC, Power Distribution, HTU Analog .....	46
APPENDIX B-2 - SCHEMATIC, Power Distribution, HTU GFI Analog .....	48
APPENDIX C - Host Interface Cables – PIN-OUT Tables .....	50
APPENDIX D - Accessory Parts List.....	52
APPENDIX E - Service Parts List.....	53
APPENDIX F - Pump Performance Curves – Available Flow and Pressure.....	54
APPENDIX G - Predicted Thermal Performance Curves.....	56
APPENDIX H - Predicted Thermal Performance Curves.....	57

**HTU FIELD FAILURE REPORT**

**LEGAL NOTICES, LIMITATIONS AND DISCLAIMERS**

**BOC Edwards – Address and Phone Listings for BOCE World-wide Sales and Service Centers(back cover)**

The HTU-108 Series Heat Exchanger Instruction Manual is available in the following translations:

Language	Edwards part number
English	W99900001
French	W99900002
German	W99900003
Italian	W99900004
Japanese	W99900005

For each HTU-108 Series Heat Exchanger purchased, you are entitled to one translated manual free of charge. This is in addition to the English version provided. Fax this completed form to the nearest Edwards location to receive your complimentary translation.

Name: _____
Title: _____
Company: _____
Address: _____
_____
HTU-108 Series Heat Exchanger serial number: _____
Language: (circle one)
French
German
Italian
Japanese

## **1. INTRODUCTION**

## 1.1 Scope of the manual

This manual provides information on the installation, start-up, operation, and maintenance of the BOC Edwards **Model HTU-108 Series Heat Exchanger**; hereafter referred to as the HTU. Technical specifications are summarized in Chapter 2. Installation is covered in Chapter 3. Operation is reviewed in Chapter 4. Maintenance is described in Chapter 5.

## 1.2 Description of the HTU

The HTU is a recirculating water cooler designed to meet or exceed the specific cooling requirements for **Applied Materials “ENDURA” series process tools (e.g. “CL” and “SL” tools)**. Its main function is to provide forced recirculation of primary coolant (de-ionized water) to and from the process tool as required to maintain process tool target and chamber temperatures within acceptable limits fixed by design.

The HTU is capable of removing up to 100kW of heat while maintaining a primary supply coolant temperature value that is no more than 15°C greater than the facility supply water temperature at rated conditions (see Chapter 2 for complete description of performance specifications).

## 1.3 Lockout Procedure

To prevent accidental or unauthorized activation of the HTU during maintenance, the customer is required to provide a main electric power disconnect with 10,000 ampere interrupt current (AIC) rating, equipped with padlockable safety lock-out disconnect switch lever; and located in close proximity to and within direct sight of the HTU. See Facility specifications defined in Section 2.2.

<p><b>Warning</b></p> 	<p>Failure by customer to install proper padlockable safety lock-out disconnect with 10,000 ampere interrupt current (AIC) rating could result in injury or death to persons.</p>
-----------------------------------------------------------------------------------------------------------	-----------------------------------------------------------------------------------------------------------------------------------------------------------------------------------

## 1.4 Safety Features and Interlocks

**Table 1.1: HTU Safety Features and Interlocks**

(\*Symbols used in Appendix-B, Power Distribution Schematic, unless otherwise stated)

<b>Component</b>	<b>Symbol *</b>	<b>Function</b>
Emergency Off button	EMO	To manually de-energize pump and DC power supply (PSU-1)
Ground Fault Interrupt	GFI	Automatically removes main power when total leakage current to ground exceeds 30mA
Main Circuit Breaker	CB1	Automatically removes main power to 24VAC Transformer (T1), DC power supply (PSU-1), and pump when main current exceeds 15A rating.
Integral Self-Protected Starter	K2	Automatically removes power to pump in response to over-current, short-circuit, and/or motor overload condition(s)
Electrical Box Interlock Switch	Elect. Box Interlock Sw	Upon opening of front control panel, shuts off power to pump and DC power supply (PSU-1)
Reservoir Low Level Switch #1	LLS1	Shuts off power to pump when Reservoir liquid level is less than 13.2 liters (3.5 U.S. gallons)
Excess Leak Level Switch	LS3	Shuts off power to pump whenever leakage water level in unit base pan exceeds 16mm (5/8 inch)
D.I. Cartridge Service Shut-off Valve, LOCKABLE	V1 (see Table 1.2)	To manually shut off supply coolant flow to D.I. Cartridge hose line during cartridge change; padlockable to prevent unintended release of coolant during service

**1.5 Safety Symbols used in this Manual**

A variety of safety symbols are used throughout this manual. A description of each is given below.

<b>General Alert</b> 	General Alert symbol denotes the potential of personal hazards or equipment failure.
-----------------------------------------------------------------------------------------------------------	--------------------------------------------------------------------------------------

<b>Warning</b> 	Warnings are given when failure to observe the instruction could result in injury or death to persons.
-----------------------------------------------------------------------------------------------------	--------------------------------------------------------------------------------------------------------

<b>Caution</b> 	Cautions are given where failure to observe the instructions could result in damage to the equipment, associated equipment and process.
-----------------------------------------------------------------------------------------------------	-----------------------------------------------------------------------------------------------------------------------------------------

<b>Electric Shock</b> 	Electric shock symbol denotes the presence of high voltage or current. It calls attention to the procedure, practice, or the like, which, if not done correctly or adhered to, could result in injury or death.
--------------------------------------------------------------------------------------------------------------	-----------------------------------------------------------------------------------------------------------------------------------------------------------------------------------------------------------------

<b>Eye Protection</b> 	Eye Protection symbol denotes a hazard which could cause injury or irritation to the eyes.
--------------------------------------------------------------------------------------------------------------	--------------------------------------------------------------------------------------------

<b>Hot Surfaces</b>	Hot Surfaces symbol denotes a hazard which could cause injury or
---------------------	------------------------------------------------------------------

	<p>burns.</p>
-----------------------------------------------------------------------------------	---------------

<p><b>Hand Protection</b></p> 	<p>Hand Protection symbol denotes a hazard which could cause injury or burns.</p>
-----------------------------------------------------------------------------------------------------------------	-----------------------------------------------------------------------------------

<p><b>High Pressure</b></p> 	<p>High Pressure symbol denotes a personal hazard or equipment failure. It calls attention to the procedure, practice, or the like which, if not done correctly or adhered to, could result in equipment damage, injury, or death.</p>
---------------------------------------------------------------------------------------------------------------	----------------------------------------------------------------------------------------------------------------------------------------------------------------------------------------------------------------------------------------

<p><b>Extreme Temperature</b></p> 	<p>Extreme Temperature symbol denotes a hazard which could cause injury or burns.</p>
-----------------------------------------------------------------------------------------------------------------------	---------------------------------------------------------------------------------------

## 1.6 Principles of Operation

The HTU supplies coolant (at or near room temperature) to the process tool via a single 1" hose line and accepts the heated return coolant (at temperatures up to 50C) through up to eight individual, 5/8" hose lines. The heated return coolant is then cooled by a chilled facility water supply (at 22°C or less) by means of a direct water-to-water heat exchanger, before being recirculated back out to the process tool.

### 1.7 Design Concept

The HTU coolant plumbing system consists of a main cooling loop, a back pressure regulator (BPR) by-pass loop, and a de-ionization by-pass loop. A schematic representation of the HTU coolant plumbing system is given in Figure 1.1. The numbered items in Figure 1.1 are defined in Table 1.2. Each sub-system is described below.

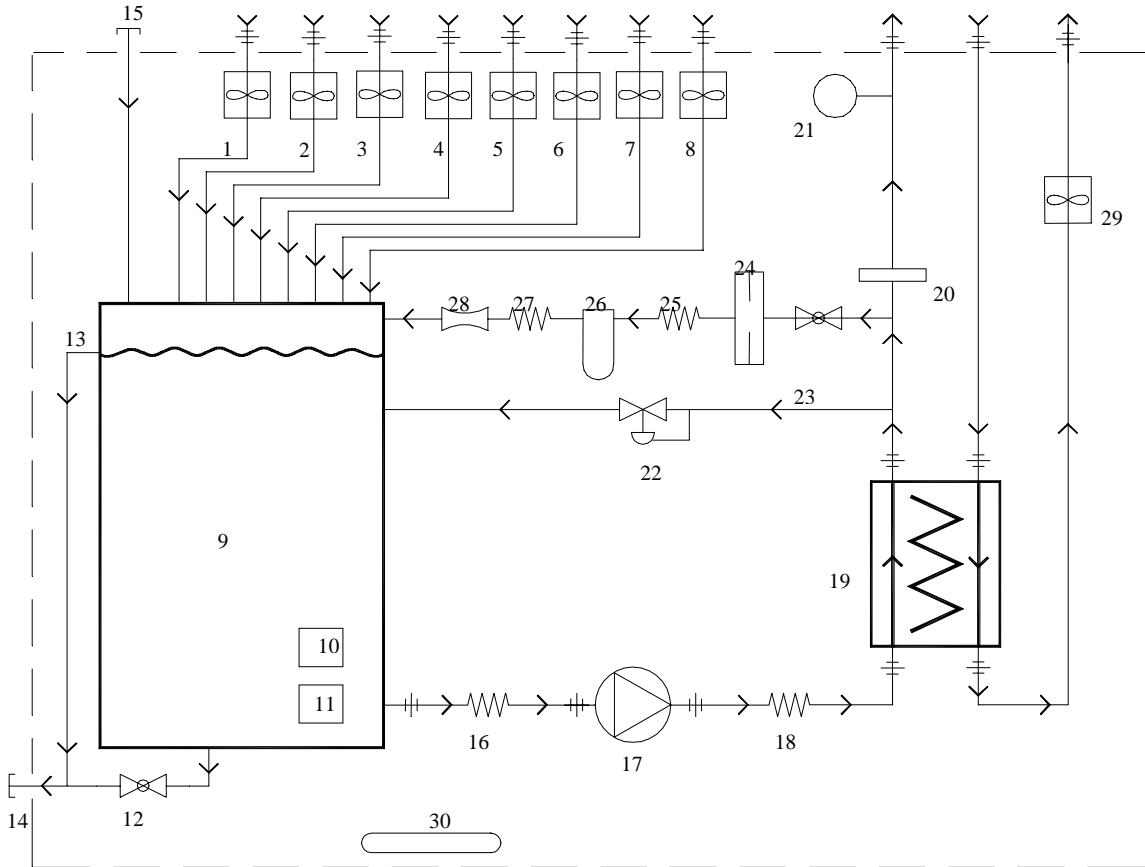

Figure 1.1 - HTU Plumbing Schematic

**TABLE 1.2**

Index of Components shown in Figure 1.1

<b>Item No.</b>	<b>Component Description</b>	<b>Component Label</b>
1-8	(8) Primary Return Line	Return 1, Return 2, ... Return 8
9	Reservoir	RESERVOIR
10	Switch, Low Reservoir Level Warning	LLS2
11	Switch, Low Reservoir Level Fault	LLS1
12	Valve, Reservoir Drain	DRAIN VALVE
13	Overflow Tube (open to main drain)	(inside Reservoir, no label)
14	Main Drain Connection (1/2"NPT)	DRAIN/OVERFLOW
15	Fill Plug, Reservoir	FILL PLUG
16	Flex Hose Line, Pump Suction-side	(white on green flow arrow)
17	Pump	PUMP
18	Flex Hose Line, Pump Discharge-side	(white on green flow arrows)
19	Heat Exchanger	HEAT EXCHANGER
20	Resistivity Probe/Temperature Sensor	RP/T
21	Pressure Sensor	P1
22	Back Pressure Regulator Valve	BPR
23	Lockable Shut-off Valve, D.I. Cartridge	V1
24	Flow Constrictor	FC
25	Flex Hose Line to D.I. Cartridge	(white on green flow arrows), IN
26	D.I. Water Filter	D.I. Cartridge
27	Flex Hose Line from D.I. Cartridge	(white on green flow arrows), OUT
28	Switch, D.I. Cartridge Flow	FS-1
29	Flow Meter, Facility Return Line	FM-F
30	Alarm - water leak surface sensor	LEAK

**1.7.1 Main Cooling Loop** includes eight (8) return flow meters, a reservoir, a circulation pump, a heat exchanger, and three (3) supply-side sensors (temperature, pressure, and volume resistivity). See Figure 1.1, above.

Return Flow Meters (labeled “Return 1”, “Return 2”, ... “Return 8”). The heated coolant returning from the process tool empties into the reservoir through (8) individual flow meters. Each flow meter transmits back to the HTU microprocessor controller the corresponding return flow rate. The microprocessor compares each flow rate against user defined (or factory default) warning level values. If measured values are less than the warning levels, the microprocessor informs the process tool host controller. Appropriate corrective action is then taken either by the host controller or by an operator. The microprocessor adds all eight return flow meter readings then displays this value on the HTU front panel as "FLOW SUPPLY." The displayed value is accurate to within +/-20%.

## **Reservoir**

The reservoir is designed to store the initial coolant charge of DI water as well as any make-up water and excess bypass water during operation. Two level switches are located near the bottom of the reservoir to monitor both warning and fault water level conditions. When a low level warning signal is detected by the HTU microprocessor, it relays that status back to the host controller. A low level fault signal will de-energize the starter contactor K2 to shut down the pump. This event is relayed back to the host controller as a low flow condition. This is one of three control actions initiated by the HTU that can intentionally interrupt process tool operation. The second HTU fault condition that will interrupt process tool operation is the Leak Level Fault (located on inside base of the HTU – to remove power from pump in event of catastrophic leak within the unit); it too will cause the HTU to send in a Low Flow Warning back to the host controller. The third HTU fault condition that will interrupt process tool operation occurs when the pump integral starter (“K2” on schematic in APPENDIX B) opens due to a motor overload condition.

## **Pump**

The pump is designed to provide adequate coolant flow required to maintain proper temperature rise across the tool cooling loop, and adequate coolant supply pressure to overcome system pressure drops which includes both pressure drops within the HTU and in external (customer-side) plumbing loop (hoses, fittings, valves, process tool, etc.). Performance charts describing available flow and pressure are given in APPENDIX F.

## **Heat Exchanger**

The heat exchanger is a device in which energy is transferred from a heated (hot-side) fluid to a cooler (cold- side) fluid across a solid surface. Hot-side fluid is the re-circulating coolant; cold-side fluid is chilled facility cooling water. This device is designed to transfer heat from the hot-side fluid to the cold-side fluid at rated thermal performance conditions (see Chapter 2). Actual performance will vary above and below this rated performance depending on process heat load, return coolant temperature, flow rate, and facility water supply conditions. Predicted thermal performance at various temperature and flow rate conditions are provided in APPENDIX G.

## **Volume Resistivity/Temperature Probe and Pressure Sensors**

All three sensors are located within the HTU on the main coolant supply line. Outputs from these three sensors are transmitted back to the HTU microprocessor and displayed (in the NORMAL mode) on the front control panel, along with the Supply Flow Rate. Warning level values are defined for each; see Appendix A-4. (Examples: high temperature warning, high pressure warnings, low resistivity warning.) An analog (or optional serial, available in DeviceNet) temperature value is transmitted back to the tool host controller on a continuous basis. Low resistivity warning is also transmitted back to the host controller for corrective action by tool operator.

### **1.7.2 Back Pressure Regulator (“BPR”) By-pass Loop**

The function of this plumbing circuit is to maintain a steady coolant supply pressure to the process tool, and to divert any excess flow directly back into the Reservoir. The main component is the Back Pressure Regulator valve (labeled “BPR”) which is equipped with a knurled, manual adjusting stem. A jam nut is included to prevent any unintended change in set

point due to vibration. Clockwise rotation of the stem decreases coolant supply pressure; counter-clockwise rotation increases it. Coolant supply pressure is measured and observed as indicated under Volume Resistivity/Temperature Probe and Pressure Sensors above.

### 1.7.3 De-ionization By-pass Loop

The function of this plumbing circuit is to maintain an adequate volume resistivity level (>600 kOhm-cm) of the entire coolant charge volume. A portion of the main coolant supply flow (0.5-to-3gpm) is continuously diverted through a de-ionizing cartridge to remove impurities, and the purified coolant is directly discharged back into the Reservoir. Components include a flow constrictor, ball valve, de-ionization cartridge, and a flow switch. See Figure 1.1, above.

#### Flow Constrictor

This device is a calibrated orifice designed to limit this by-pass flow rate to the maximum allowed for the given de-ionization cartridge (3 gpm).

#### Ball Valve

This device is a padlockable shut-off valve, used to isolate the DI by-pass loop from the main coolant supply flow and pressure. It makes it possible for service personnel to remove and replace the DI cartridge without having to shut the HTU pump off. The valve is padlockable to prevent unintended release of coolant during this cartridge replacement procedure (described in section 5.5 of this manual). Cartridge replacement intervals vary from one installation site to another. In general, the tool operator may elect to replace the DI cartridge whenever a resistivity warning is indicated on either the HTU front control panel or the process tool host controller.

#### De-ionization Cartridge

Present specifications for this component require (1) Barnstead P.N. D8901, Hose Nipple Cartridge; = AMAT P.N. 4020-01140. This is listed by Barnstead as a high capacity, single ion exchange, up-flow cartridge. Outer plastic housing and integral 3/8-inch hose barb fittings are polypropylene. For ease of service, it is bracket-mounted on the inside surface of the lower front access door of the HTU. Rated total ion exchange capacity is 100 grams (= 1600 grains) NaCl to an end point of 50,000 ohm-cm. Maximum rated temperature and pressure are 49°C and 65 psi.

#### Flow Switch

The function of this switch is to detect insufficient coolant flow (equal to or less than 0.1gpm) through the DI by-pass loop, then illuminate a "DI FLOW WARNING" warning indicator on the HTU front control panel and simultaneously transmit the warning signal back to the process tool host controller.

**(END OF CHAPTER 1)**

## 2. TECHNICAL DATA

### 2.1 Storage Conditions

Ambient temperature range----- +10°C to +40°C (50°F to 104°F)

Maximum Ambient Humidity range ----- 80%

## 2.2 Facility Requirements to be Provided by Customer

Ambient temperature range (operation)-----	10°C to 40°C (50°F to 104°F)
Maximum ambient relative humidity (operation)-----	80%, up to 31°C (88°F) Derate linearly to 50% at 40°C (104°F)
Required main power overcurrent protection -----	15Amps
Required main power earth leakage protection -----	trip at 30 milliAmps
Main Power Disconnect Lock-out Protection -----	10,000 ampere interrupt current (AIC) rating, padlockable in OFF position
Electrical supply voltage (nominal) -----	200/208 Vac
Electrical supply voltage (min/max) -----	177/228 Vac
Electrical supply frequency-----	50/60 Hz
Electrical supply, number of phases-----	3
Supply water temperature range -----	15°C to 22°C (59 to 72 °F)
Supply water pressure range -----	3.45 to 5.5 bar (50 to 80 psi)
Supply water flow range-----	30 to 76 lpm (8 to 20 gpm)

## 2.3 Physical Data

Overall Dimensions -----	610mm x 686mm x 1016mm (24"x27"x40")
Center of Gravity Location (DRY, calculated) -----	(SEE FIGURE 2.1, below)
Corner Load on each Caster (DRY, calculated) -----	(SEE Table 2.1, below)
Total Weight (DRY) -----	182kg (400 lbs.)
Total Weight (WET) -----	288kg (633 lbs.)
Maximum Reservoir Capacity -----	105.8 Liters (28 U.S. gallons)
Maximum Available Reservoir Capacity -----	79.4 Liters (21 U.S. gallons) as measured between "Warning " level and overflow drain level
Reservoir Water Volume at <b>WARNING</b> Level -----	26.5 Liters (7 U.S. gallons)
Reservoir Water Volume at <b>FAULT</b> Level -----	13.2 Liters (3.5 U.S. gallons)
Maximum tilt angle (DRY) -----	15° (no coolant in unit)
Primary Coolant Supply Fitting (1) -----	1" Female NPT
Primary Coolant Return Fitting (8) -----	1/2" Female NPT
Facility Water Supply Fitting (1) -----	1" Female NPT
Facility Water Return Fitting (1) -----	1" Female NPT
Reservoir Fill Port (1) & Plug (1) -----	1-3/4" diameter
Main Drain Fitting(1) -----	1/2" Female NPT

**Figure 2.1: HTU - Center of Gravity Location (DRY)**

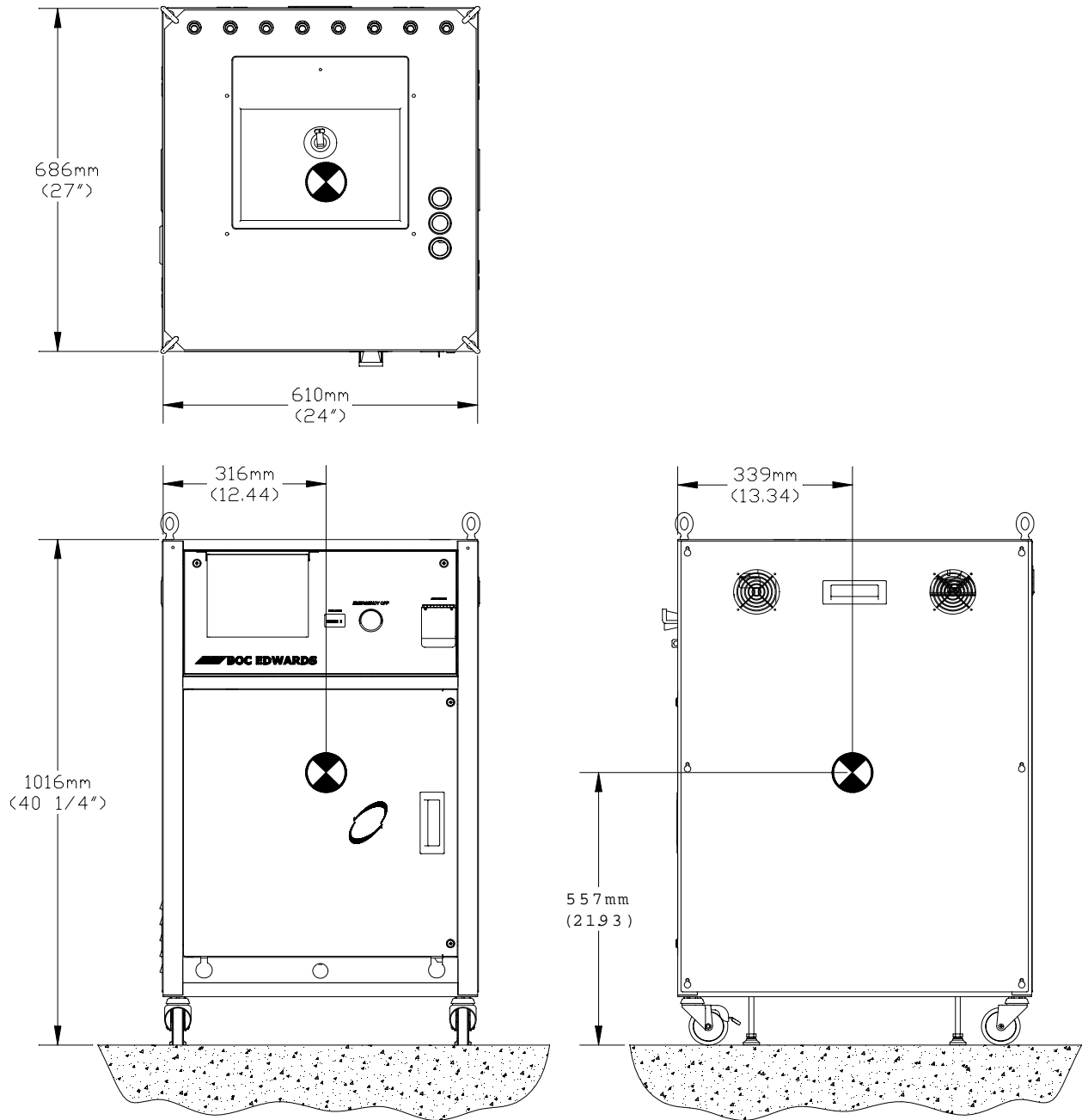

**Table 2.1: HTU - Corner Load on each Caster (DRY, calculated)**

Caster Position	Load, kg (lbs.)
Left Front	45 (100)
Right Front	47 (103)
Left Rear	44 (97)
Right Rear	46 (100)

Primary Coolant Supply temperature range ----- 15°C to 30°C (59 to 86°F)  
 Primary Coolant Supply flow range ----- 38lpm to 151 lpm (10 to 40gpm)  
 Primary Coolant Supply pressure range----- 0.7bar to 3.45 bar (10 to 50 psi)  
 Maximum Primary Coolant Supply temperature----- 37°C max. (99°F max.)  
 Maximum Primary Coolant Return temperature ----- 65 °C max. (149°F max.)

**2.5 Allowable Operating Conditions on 200V/3-phase/50Hz Main Power**

Primary Coolant Supply temperature range ----- 15°C to 30°C (59 to 86°F)  
 Primary Coolant Supply flow range ----- 38lpm to 121 lpm (10 to 32gpm)  
 Primary Coolant Supply Pressure Range ----- 0.7bar to 3.1 bar (10 to 45 psi)  
 Maximum Primary Coolant Supply temperature----- 37°C max. (99°F max.)  
 Maximum Primary Coolant Return temperature ----- 65 °C max. (149°F max.)

**2.6 Rated Thermal Performance on 200V/3-phase/50Hz Main Power**

Cooling capacity (@stated conditions)----- 100 kW  
 AC power source-----200Vac, 50 Hz  
 Difference (primary supply water temp - facility water temp)---- Not more than 15 °C  
 Primary Coolant Supply flow rate ----- 76 lpm (20 gpm)  
 Facility Supply Water flow rate ----- 76 lpm (20 gpm)  
 Facility Supply Water temperature ----- 22 °C (72°F)

**2.7 Rated Performance of Pump at 200V/3-phase/50Hz Main Power**

Rated Flow Capacity ----- 114 lpm (30 gpm) min.  
 Rated Pressure Capacity ----- 2.4 bar (35 psig)  
 Minimum Allowable Supply Voltage at 50Hz ----- 187 Vac  
 Typical maximum surface temperature----- 75°C (167°F; motor casing)

**2.8 Analog Communication Interface Connectors (to be supplied by customer)**

Main Interface Connector “P1” ----- 28-pin, Amp P.N. 205839-3  
 EMO Connector “P2” ----- 4-pin, Amp P.N. 206060-1  
 Leak Detect Connector “P3” ----- 4-pin, Amp P.N. 206429-1  
 EMO Connector “P4” ----- 4-pin, Amp P.N. 206060-1  
 Optional Analog Adapter Plate  
 Connector “R<sub>1</sub> through R<sub>8</sub>” ----- 4 Pin, Amp P.N. 206429-1

**NOTE** – See **APPENDIX C** for complete description of each connector; “P2” and “P4” provide means for customer to daisy-chain EMO with other equipment.

**2.9 DeviceNet Serial Communication Interface (To be supplied by the customer)**

Required connector type -----5-pin, 12mm circular DIN,  
 (e.g female TURCK “Eurofast” cordset)

**(END OF CHAPTER 2)**

### 3. INSTALLATION AND SETUP

This section describes all of the steps that must be performed from the removal of the unit out of its packing crate to verification of correct pump motor phase rotation.

#### 3.1 Unpacking and Inspection

Unpacking procedure:

- a. Cut straps that secure cardboard cover to pallette.
- b. Open the top flaps to cover and remove the shock absorbing material.
- c. Lift cardboard cover straight up and off of the HTU.
- d. Cut straps that secure HTU to wooden pallette.
- e. Remove plastic wrap and bubble pack to expose HTU.
- f. Visually inspect the HTU for any physical damage.
- g. Lift the HTU from the wooden pallette with approved handling equipment; e.g., use overhead hoist to lift with lifting eyes fastened to top of HTU, or use fork lift to lift from underside of HTU.



<b>General Alert</b> 	Read and understand all Physical Data found in Section 2.3 of this manual before attempting to lift or move the HTU. Only proper handling practice by qualified personnel should be employed to handle this equipment in order to avoid potential of personal hazards or equipment failure.
---------------------------------------------------------------------------------------------------------------	---------------------------------------------------------------------------------------------------------------------------------------------------------------------------------------------------------------------------------------------------------------------------------------------

#### 3.2 Siting

With the unit removed from its packing crate, the next step is to move it to the place where it will be used. This place must be within 50 feet of the process tool. If it is sited at a lower level, that level cannot be more than 31 feet below the process tool.

Safe handling practice and approved handling equipment must be pre-planned and implemented in order to avoid injury to personnel and equipment during transport of the HTU to its final installation.

<b>CAUTION:</b> 	Whenever moving HTU across floor on its casters, observe safe handling practice; for example, (a) the HTU <b>MUST NEVER BE MOVED WITH WATER IN THE RESERVOIR</b> ; (b) the handler must <b>ALWAYS PUSH</b> the HTU (dry) to its destination – <b>NEVER PULL UNIT TOWARDS ONES BODY</b> .
--------------------------------------------------------------------------------------------------------	------------------------------------------------------------------------------------------------------------------------------------------------------------------------------------------------------------------------------------------------------------------------------------------

<p><b>CAUTION:</b></p> 	<p>Once in its final installation position, the two front casters on the HTU must be locked to secure from rolling, and the four leveling feet must be lowered to make firm contact with floor and level the HX 1530; refer to Figure 3.1.</p>
<p><b>General Alert</b></p> 	<p>To avoid potential of personal hazards or equipment failure due to unintended movement of HTU,  <b>ALWAYS LOCK BOTH FRONT LOCKING CASTERS AND LOWER ALL FOUR (4) LEVELING FEET FIRMLY TO FLOOR SURFACE.</b>  <b>Customer is responsible for ensuring that installation of the HTU complies with all applicable local codes and practices.</b></p>

If mechanical fastening of the HTU to the floor is required in order to meet local seismic codes/practices, please order BOC Edwards P.N. P60208400, **Stabilization Kit (see Appendix D: Accessory Parts List)**. Installation of this accessory kit is illustrated in Figure 3.2.

### 3.3 Plumbing Installation

The HTU is equipped with one Primary coolant supply fitting, eight Primary coolant return fittings, one Facility water supply fitting, one Facility water return fitting, one Drain fitting, and one Reservoir Fill Port & Plug. The position of each fitting on the HTU is illustrated in Figure 3.1, Plumbing Connections, below. Specifications for each fitting are defined in section 2.7, “Physical Data”.

**Hose Adapter Fittings** - The customer is required to provide the appropriate adapter fittings and hose materials necessary to complete each fluid connection between the HTU and process tool; call your local BOC Edwards Service Center for fitting options and accessories (see phone listing on back cover).

**Hose Selection** - Primary coolant supply, Facility water supply, and the Facility water return hose assemblies external to the HTU are expected to be 25.4mm (1-inch) internal diameter size. Primary coolant return hose assemblies external to the HTU are expected to be 15.9mm (0.625-inch) internal diameter size. Total length of each line must not exceed 50 feet. The maximum number of Primary coolant return lines must be limited to eight (8). The actual required number of Primary coolant return hose lines will vary depending on each process tool and its intended application. Each Primary coolant return line must be plumbed as direct as physically possible from the process tool back to the HTU. Each return line to the HTU must come from only one process tool outlet line; i.e., combining return lines will not be permitted.

**GENERAL NOTES** – During installation of each fitting below, apply only Loctite No. 567 Thread Sealant to metal pipe fittings and allow adequate sealant curing time before exposing fitting to water flow and pressure. **DO NOT** use hose diameters less than those stated above; each hose line length must be no longer than 15.24 meters (50 feet; maximum allowed). **MINIMIZE** the number of bends in each hose line in order to optimize available Primary coolant supply flow rate and pressure.

**Facility Supply and Return Water Lines** – Verify that Facility supply water source temperature, pressure and available flow rate comply with corresponding specifications listed in Section 2.2, Facility Requirements. Install the appropriate Facility supply water hose assembly from Facility supply source fitting, to Facility supply fitting on HTU (Item 10, Figure 3.1). Install the appropriate Facility return water hose assembly from Facility return source fitting, to Facility return fitting on HTU (Item 9, Figure 3.1).

**Primary Coolant Supply Line** – Install the appropriate Primary coolant supply hose assembly from Primary coolant supply fitting on HTU (Item 11, Figure 3.1), to coolant supply manifold fitting at the process tool.

**Primary Coolant Return Line** - Install the appropriate Primary coolant return hose assembly from each process tool coolant return fitting, to the corresponding Primary coolant return fitting on HTU (Item 1,2,3,4,5,6,7,or 8, Figure 3.1).

**Overflow/Reservoir Drain Line** – Install appropriate Drain hose assembly from Drain port fitting on HTU (item 13, Figure 3.1; described in section 2.3) to Facility drain source fitting.

NOTE: Customer is required to provide proper drain plumbing in order that the HTU comply with SEMI S2-93A secondary containment clause.

Allow adequate time for liquid pipe thread sealant to cure, before proceeding to next step.

Add De-ionized water to Reservoir – Unscrew the plastic Fill Plug (item 15, Figure 3.1) and slowly raise from sink Fill Port; then remove level indicator (item 16, Figure 3.1). Add 25 gallons of de-ionized water to reservoir. Reinstall level indicator and Fill Plug.

Adjust Back Pressure Regulator Valve (BPR) to Full Open position - Open lower front door and verify that the BPR knurled adjustment stem is fully extended above (but not removed from) the valve body. Then gently hand-tighten the stem jam nut down onto the valve body to lock this stem position; refer to section 1.6.2 for more details.

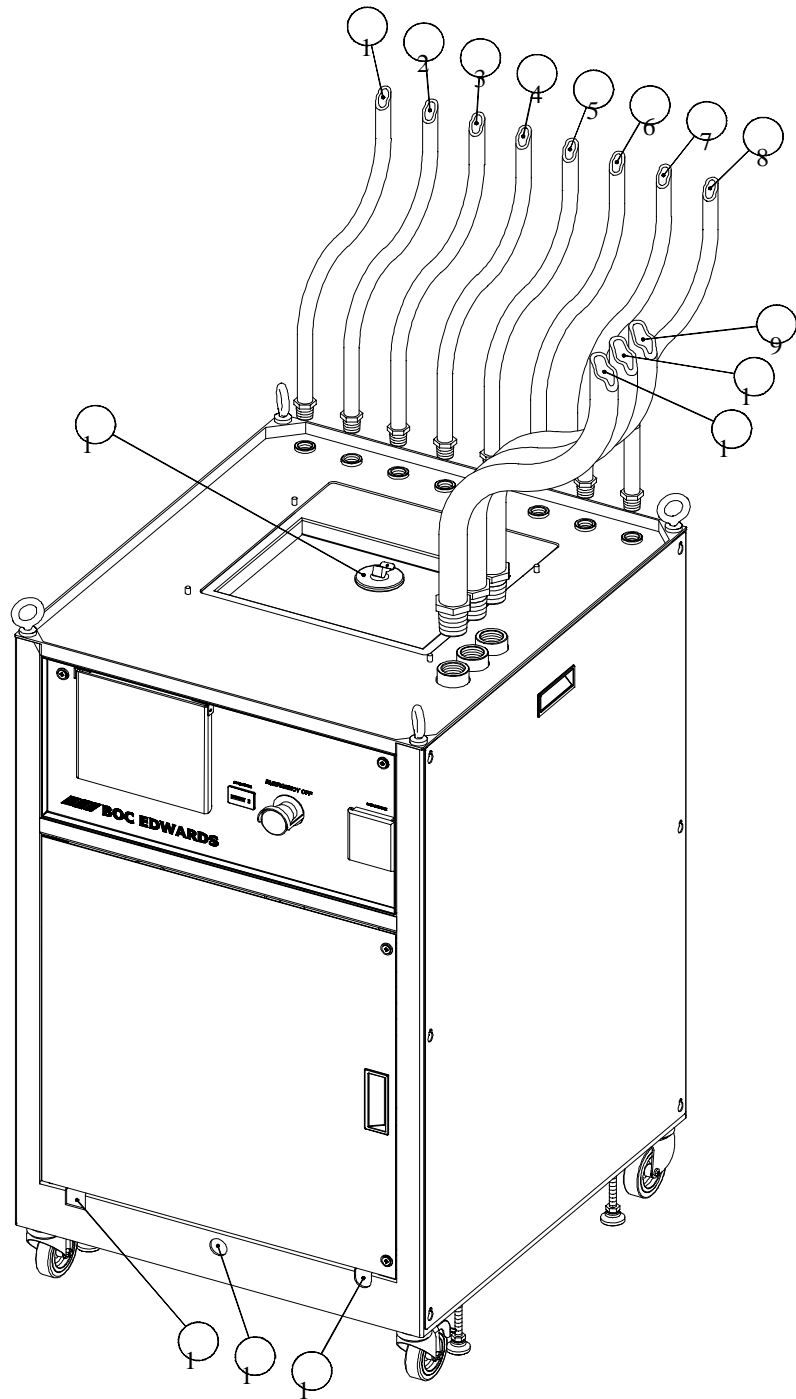

**Figure 3.1 - Plumbing Connections and Electrical Feedthroughs (see Table 3.1)**

**TABLE 3.1 – Plumbing Connections and Electrical Feedthroughs**  
 (all items are shown in Figure 3.1 unless stated otherwise)

<b>ITEM NO.</b>	<b>DESCRIPTION</b>
1	Primary Coolant Return No.1
2	Primary Coolant Return No.2
3	Primary Coolant Return No.3
4	Primary Coolant Return No.4
5	Primary Coolant Return No.5
6	Primary Coolant Return No.6
7	Primary Coolant Return No.7
8	Primary Coolant Return No.8
9	Primary Coolant Supply
10	Facility Water Supply
11	Facility Water Return
12	Feed through, Main Power Cable
13	Facility Drain Fitting
14	Feed through, Data Cable(s)
15	Reservoir Fill Port & Plug
16	Reservoir Level Indicator (not shown; located beneath item #15)

# STABILIZATION KIT TEMPLATE



Use this template to easily locate the four "U" shape fittings on the mounting surface.  
 Figure 1 illustrates a mounting method using concrete anchor bolts. (Not supplied)  
 Other methods (such as using lag bolts in the case of wood floors) are also viable.

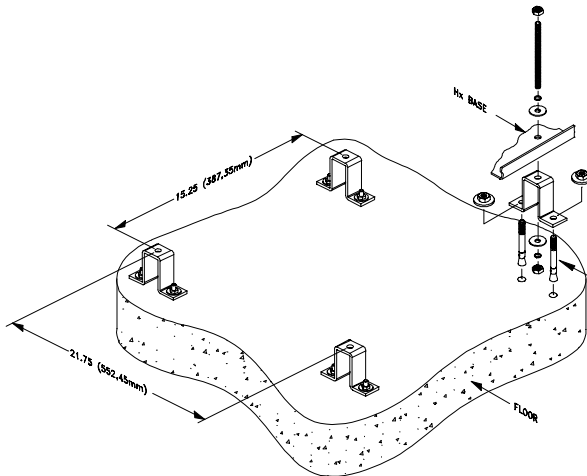

Figure 1

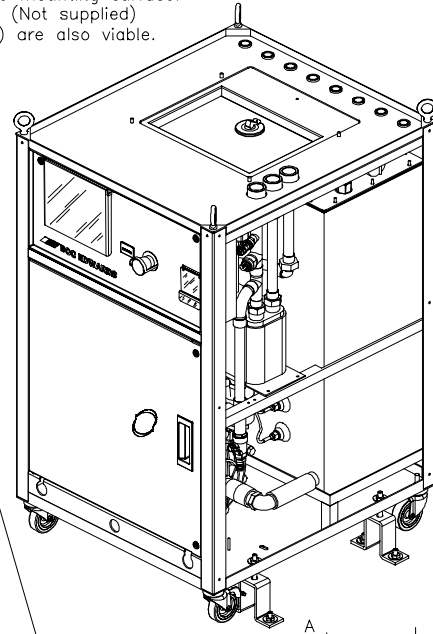

Figure 2

Secure to floor using  
 concrete anchors  
 (Not supplied)

"U" fitting mounting positions  
 8 places marked "A"

FRONT

**Figure 3.2: HTU 108 Stabilization Kit Installation (NOT TO SCALE)**

- 3.3 On models W990200000 and W990300000, CB1 and the GFI are separate components. The GFI is located in its own electrical enclosure accessible through the lower front door.

### 3.4 Electrical Installation

This section describes the installation of the main power cable, and all host interface cables (for analog and serial communication). Figure 3.3, below, illustrates the connections to be made.

#### Main Power Disconnect

The main power provided by the customer must conform to “Facility Reuirements” stated in Section 2.2 of this manual.

<p><b>Electric Shock</b></p> 	<p>Electric shock symbol denotes the presence of high voltage or current. It calls attention to the procedure, practice, or the like, which, if not done correctly or adhered to, could result in injury or death.</p> <p>Before connecting AC power to the HTU, be CERTAIN that power is disconnected at the other end, so that you are not handling “hot” wires.</p>
----------------------------------------------------------------------------------------------------------------	------------------------------------------------------------------------------------------------------------------------------------------------------------------------------------------------------------------------------------------------------------------------------------------------------------------------------------------------------------------------

#### Main Power Cable

Minimum specifications for the main power cable selection (to be provided by customer) must include 12AWG, 4-conductor, type SO cable (or equivalent; conductor ampacity to be 16 amps or greater, insulation to be 90°C rating, oil and water resistant). The customer must provide and assemble Ring Lug connector on each of the four (4) conductors; ring lug width to be 17mm max., with mounting through hole for M5x14 screw terminal.

#### Installation of Main Power Cable:

1. Verify that Main Power Disconnect at power source is in the OFF position.
2. Use a No.1 Phillips head screw driver to open both the lower front door and the control panel door by turning each latch counter-clockwise.
3. Feed the main power cable through the rubber grommet located at the bottom right corner on the front of the HTU; up the inner right front corner of the HTU frame; then through the strain relief feedthrough connector located in the upper right rear wall of the control cabinet.
4. Pull the upper terminal cover on the earth leakage circuit breaker (“CB1/GFI” in Figure 3.3) straight out to expose screw terminals labeled 1, 3, and 5. Do not remove the yellow WARNING label from terminal cover.
5. Remove the No.10-32 hex nut, lock washer, and flat washer from the primary ground stud located on the inside, right rear wall of the control cabinet, just above “CB1/GFI”. Insert the main power “earth” ground conductor with ring lug over the HTU primary ground stud, and reassemble with flat washer, lockwasher and hex nut.
6. Install the three remaining main power ring lugs (X, Y, Z) to the three corresponding terminals (1, 3, 5) on the earth leakage circuit breaker (“CB1/GFI”). Next, reinstall the terminal cover by inserting it back into the guide grooves on CB1/GFI, and push until fully seated. Peel the backing tape away from the lower half of the yellow Warning sticker on the terminal cover and press firmly onto mating surface of CB1/GFI.

7. Tighten strain relief feedthrough grommet fitting.
8. Fasten main power cable to inside right front corner of HTU using the tie-wraps provided.
9. Verify rubber grommet in lower right front corner feed through is properly seated.

### **INITIAL POWER-UP OF HTU CONTROL SYSTEM:**

1. Verify that de-ionized water level in the reservoir is full; see Section 3.3, above.
2. Toggle the switch on CB1/GFI (see Figure 3.3) down to the OFF position.
3. If not already done, turn the knob on the integral starter (see Figure 3.3) clockwise to the AUTO (12 O'clock) position.
4. Close the front control panel; use No.1 Phillips screw driver to turn each latch screw clockwise to fasten.
5. Close the main disconnect switch at the source end to energize power cord up to CB1/GFI.
6. Toggle the switch on CB1/GFI (see Figure 3.3) upward to the ON position; the green **MAIN POWER ON** LED indicator should be illuminated.
7. Press the **POWER ON RESET** button and observe the following front panel display sequence:
  - 7a. All keypad LEDs will light momentarily.
  - 7b. Then the Liquid Crystal Display (LCD) will successively display: **POWER ON RESET**, software version number, **INITIALIZING FROM EEPROM**, before returning to a **NORMAL** display.
  - 7c. The **NORMAL** LED should be ON; all three others OFF.

### **VERIFY CORRECT PUMP ROTATION**

During initial installation of the HTU, each of the three main power phase leads must be properly sequenced in order to achieve correct pump rotation. Since the HTU control system is not equipped with a phase monitor, the customer is required to visually confirm proper direction of pump rotation.

Note in Figure 3.3, the circular arc segment with arrowhead drawn on the end of the motor housing. This arrow indicates that the correct direction of motor rotation is clockwise as viewed from the left side of the HTU.

<p><b>Caution</b></p> 	<p>Failure to verify proper pump motor rotation could result in damage to the equipment associated equipment and process.</p>
-----------------------------------------------------------------------------------------------------------	-------------------------------------------------------------------------------------------------------------------------------

1. Expose the motor end of the pump assembly as follows:
  - 1a. Loosen (but do not remove) the six (6) screws on the HTU left side access panel.
  - 1b. Simultaneously lift up and pull out panel to remove from HTU; the panel is attached via a ground cable to the HTU – DO NOT DISCONNECT GROUND CABLE. Lean the panel to one side of the unit.
  - 1c. Observe the fan guard on the motor end of the pump assembly, as viewed from the left side of the unit. Note the fan impeller to be visible through fan guard openings. A clockwise direction of rotation of this impeller will be used in steps 3, 4, 5, and 6, below, to confirm proper pump rotation.
2. Locate the keypad on the front panel control. Note there are two, oval buttons labeled PUMP (positioned in the lower left corner of the keypad). The pump ON button is immediately above the PUMP label; the pump OFF button is to the right of the PUMP label.
3. Press the pump ON button to energize the pump motor, then immediately press the pump OFF button to de-energize the pump motor.
4. Immediately observe the direction of rotation of the pump motor impeller as defined in step 1c, above.
5. **If the rotation of pump motor impeller is counterclockwise**, then shut-off the main disconnect to remove electric power from the HTU. Swap positions between two of three phases on main power cable ring lug leads that fasten into top of CB1/GFI (see paragraph above entitled “Main Power Cable:”)
6. **Reapply main power, then repeat steps 3 and 4, above.**
7. **If the rotation of pump motor impeller is clockwise**, then reassemble left-side access panel onto HTU, and proceed to next section – “Host Interface Cables:”.

**Host Interface Cables:** There are four (4) connectors located on the bottom left corner of the control cabinet; see Figure 3.3. Starting from the front and moving toward the rear, they are labeled “P1 I/O”, “P2 EMO”, “P3 LEAK”, and “P4 EMO”. The customer must provide the appropriate cable assembly from the Host Controller, to each of the four connectors. On the analog version the DeviceNet card is replaced with an analog adapter plate, housing 8 connections marked R<sub>1</sub> through R<sub>8</sub>. Each cable assembly must include the following components:

- (a) “P1 I/O” - AMP P.N. 205839-3, Plug Housing, and AMP P.N. 1-66504, Female socket contact; required crimp tool is AMP P.N. 90302-1
- (b) “P2 EMO” (and “P4 EMO”, if required, see note below) - AMP P.N. 206060-1, Plug Housing, and AMP P.N. 66101-3, Female socket contact ; required crimp tool is AMP P.N. 90067-5
- (c) “P3 LEAK” - AMP P.N. 205838-1, Plug Housing, and AMP P.N. 66504-9, Socket contact; required crimp tool is AMP P.N. 90067-5
- (d) “R<sub>1</sub> through R<sub>8</sub>” – AMP P/N 206429-1, plug housing and AMP P/N 66103-3 pin contact, required crimp tool is AMP P/N 90067-4.

## Procedure to Verify Proper Pump Rotation continued...

**Note** that “P4 EMO” is provided to allow the customer to wire EMO (emergency off) status connectors of all support equipment (e.g., vacuum pumps, heat exchangers, etc...) into one Host control circuit.

A complete description of all pin numbers in each connector assembly are given in Appendix C.

### Device Net Interface Cable

There is one (1) connector located on the bottom left half of the control cabinet. The required interface cable assembly is described in Section 2.9. Connector pin-out designation is defined in Appendix – C.

### Installation of Host Interface Cables

1. Toggle CB1/GFI switch downward to the OFF position to remove main power into the HTU.
2. Align, insert, and fasten each cable connector into place.
3. Bundle and fasten all host interface cables to inside left front corner of HTU using the tie-wraps provided.
4. Verify rubber grommet in lower left front corner feed through is properly seated.
5. Verify that DeviceNet card EPROM is compatible with process tool. To do this, open front door of electrical box and locate DeviceNet card on lower front assembly, the version label should be positioned to the lower right of the EPROM. The customer will need to cross-reference this version with the process tool software to verify compatibility.

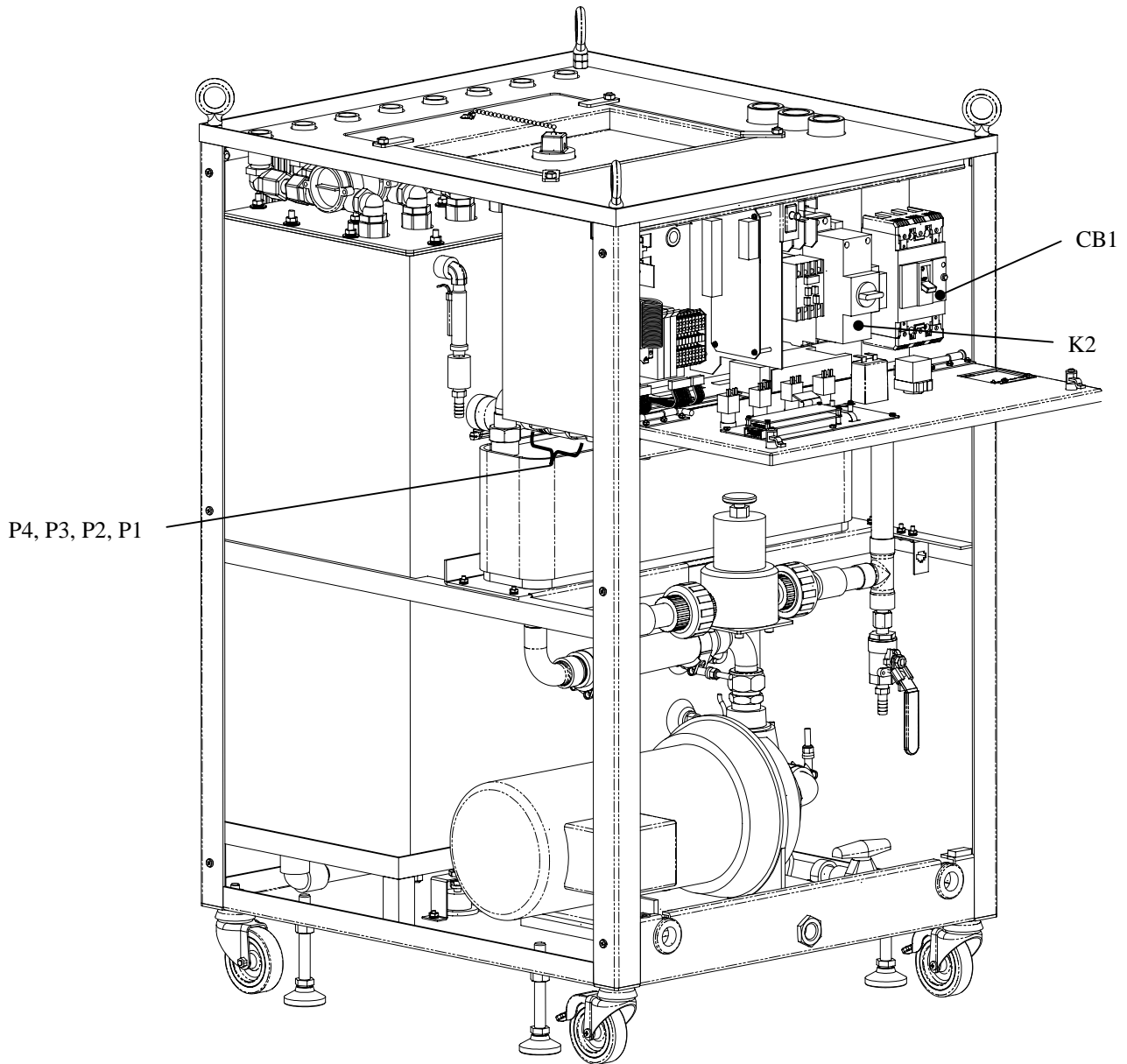

**Figure 3.3 - Connections for Main Power and Host Interface Cables**

**(END OF CHAPTER 3)**

## 4. OPERATION

The present chapter has been organized into five major sections; i.e., Front Panel Controls, Keypad and Liquid Crystal Display (LCD), Start-up Procedure, Shut Down Procedure, AC Power Distribution, Microprocessor Controls, and Host Interface Communications.

### 4.1 Front Panel Controls

An illustration of the front panel controls is given in Figure 4.1, below.

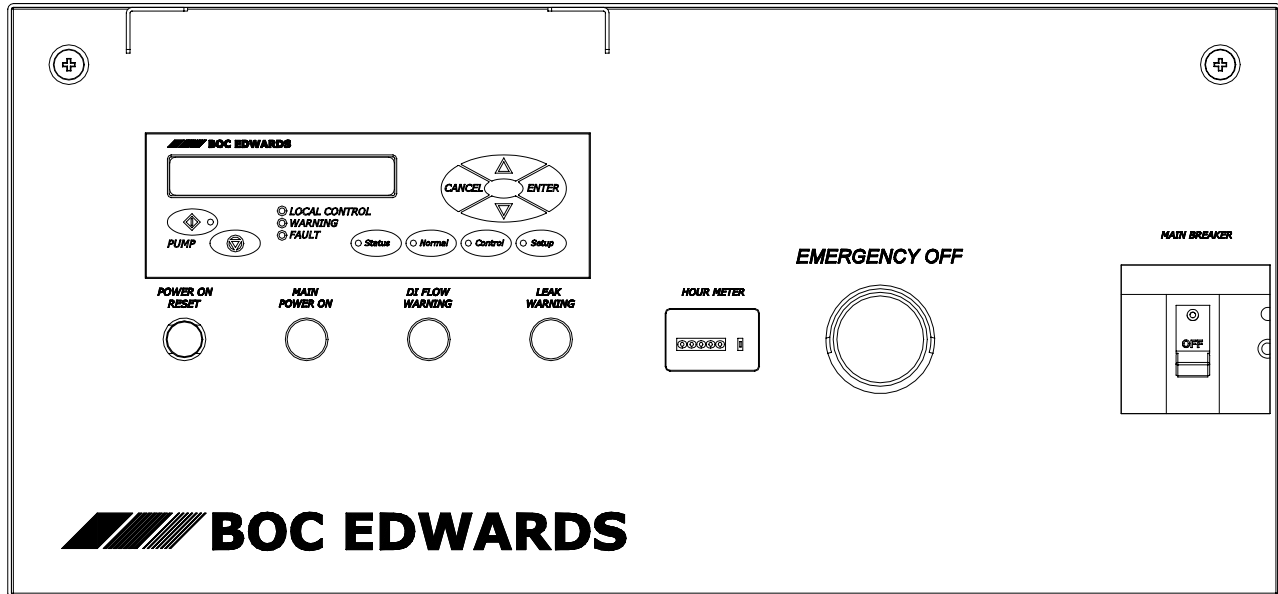

Figure 4.1: Front Panel Controls



Note that the standard clear plastic shields that protect both the components on the left half of the control panel and the MAIN BREAKER were omitted from Figure 4.1.

As viewed from left to right, front panel controls include: keypad with Liquid Crystal Display (LCD); beneath that are **POWER ON RESET** button, **MAIN POWER ON** (green color) indicator, **DI FLOW WARNING** (amber color) indicator, and **LEAK WARNING** (amber color) indicator; analog **HOUR METER**, **EMERGENCY OFF** button, and the **MAIN BREAKER** switch.

These components serve the following functions:

- " Keypad with Liquid Crystal Display - (see description in Section 4.2, below)
- " **POWER ON RESET** - Energizes high voltage supply up to pump contactor "K2", and energizes control and instrumentation DC power supply "PSU1"; requires EMO button to be in ON (released) position.
- " **MAIN POWER ON** - Indicates that there is AC power in the system up to contactor "K1".
- " **DI FLOW WARNING** - Illuminates when de-ionization cartridge flow rate drops below 0.1 gpm (0.4 lpm).
- " **LEAK WARNING** - Illuminates when water leak is detected on inside base of unit.
- " **HOUR METER** - records the cumulative elapsed time the pump has been running
- " **EMERGENCY OFF (EMO)** - Manual push button which when depressed will instantly remove high voltage supply to both the pump and the control and instrumentation DC power supply "PSU1".  
(NOTE – When manually depressed, this switch will latch in the OFF (de-energized) position. To restore power, twist the button clockwise a quarter-turn until the button pops back out to its ON (energized) position.
- " **MAIN BREAKER** - admits AC power to the system up to contactor "K1".

The front control panel is fastened to the HTU frame with a hinge on each of the bottom corners and panel screw on each top corner; SEE WARNING and CAUTION, below.

<p><b>Warning</b></p> 	<p>ONLY authorized service personnel are allowed to open the front control panel. Failure to observe this instruction could result in personal injury or death resulting from contact with HIGH VOLTAGE components within the control panel enclosure.</p>
<p><b>Caution</b></p> 	<p>The front control panel is equipped with a safety interlock switch that will de-energize the HTU each time the panel is opened for service. The process tool host controller monitors this status, and will respond by terminating process tool operation, which in turn could result in damage to associated equipment and process.</p>

#### 4.2 Keypad and Liquid Crystal Display (LCD)

An illustration of the keypad and liquid crystal display (LCD) is given in Figure 4.2, below. Starting from the top left corner of this figure is the BOC Edwards logo. Beneath logo is the Liquid Crystal Display (hereafter referred to as LCD). To the lower left of the LCD are two buttons labeled PUMP; the button directly above this label is the pump ON button, and the button to the right is the pump OFF button; the ON button has an embedded light emitting diode (LED) which illuminates green color when pump is energized. To the right of the PUMP control buttons are a column of three, LED's labeled LOCAL CONTROL (illuminates green color when active), WARNING(illuminates amber color when active), and FAULT(illuminates red color when active). Next is a row of four (4) buttons labeled from left to right as STATUS, NORMAL , CONTROL, and SETUP; these buttons allow the operator to select and enter the major display and edit menus in the HTU controller; each has embedded LED which illuminates green color when active. Pressing any one of these buttons: Status Normal Control Setup causes display to change to that particular menu. Finally, in the upper right corner there is an oval array of four buttons labeled as CANCEL, (down arrow), ENTER, and (up arrow); these buttons allow the operator to scroll through to view and/or revise the contents in each of the four major display and edit menus.

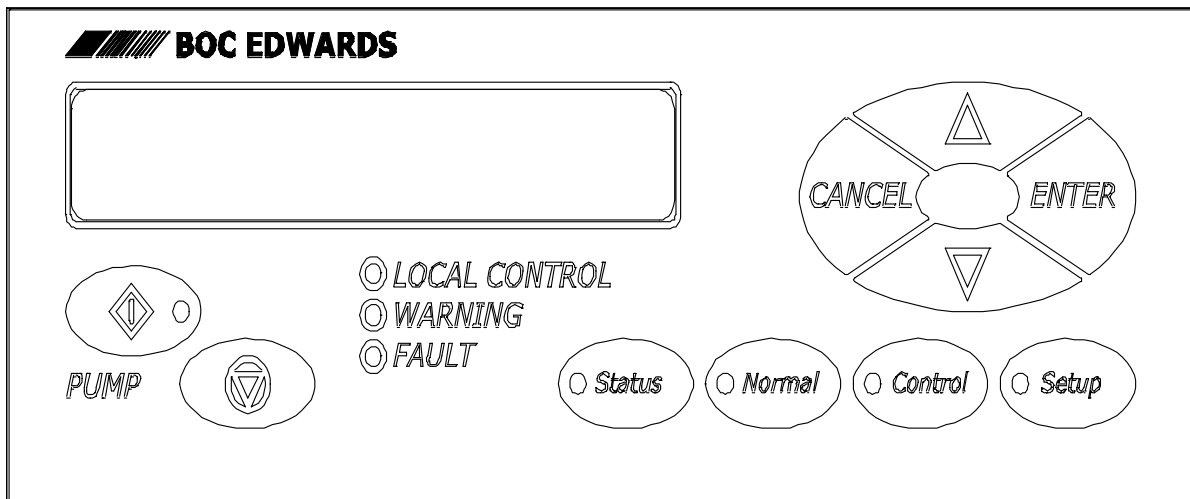

**Figure 4.2: Keypad and Liquid Crystal Display(LCD)**

These buttons and indicators serve the following functions:

" **LCD** – Provides a visual alphanumeric description of the status of all instruments onboard the HTU; capable of displaying up to 48 characters (= 24 characters x 2-row) per display page.

" **PUMP ON** and **OFF** buttons - These two buttons are used to manually control power to the pump when operating in the **LOCAL CONTROL** mode (defined below).

" **LOCAL CONTROL LED** – When illuminated indicates that the unit is in Local Control mode. When not illuminated indicates unit is in Remote Control mode, i.e., controlled by process tool host controller.

" **WARNING LED** – When illuminated indicates that one or more monitored parameters have exceeded corresponding defined warning limit values; the operator or process tool host controller is required to implement the necessary corrective action(s) in order to restore the HTU to normal operation.

" **FAULT LED** – When illuminated indicates that one or more monitored parameters have exceeded corresponding defined fault limit values. The operator and/or process tool host controller are required to implement corrective action(s) necessary to restore the HTU to normal operation or if necessary abort process tool operation. See additional descriptions in Section 1.7.1, "Reservoir", and Appendix A-5

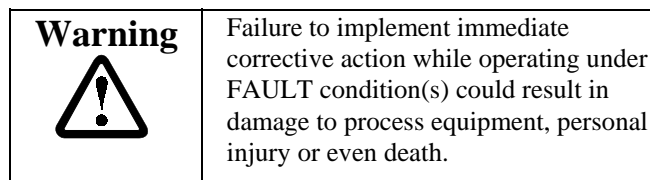

" **STATUS**: Sets the display to its **Status** menu to allow the operator to observe each parameter monitored by the HTU; the display is formatted to list one line per parameter, two parameters per display page. Each time the up-arrow or the down-arrow key are depressed, a different parameter and its value are displayed. Note that Warning List and Fault List are only displayed when scrolling with the down-arrow. See Section 4.2.1, below. Active Warnings or Faults can only be reset via the **MESSAGES** sub-menu in **SETUP**. See Section 4.2.4, below.

" **NORMAL**: Sets the display to its **Normal** menu, which is the default display mode. This menu consists of four parameters and their values; formatted to display one line per parameter, two parameters per display page, automatically scrolled between two display pages once every five seconds. The factory default display consists of **FLOW SUPPLY**, **PRESSURE**, **TEMPERATURE**, **RESISTIVITY** as described in Section 4.2.2, below. However, the operator has the option to revise the four display parameters using the **SETUP** menu; see Section 4.2.4, below for details.

" **CONTROL**: Sets the display to its **Control** menu which allows the user to select either: Remote Control, Local Control. See Section 4.2.3, below.

" **SETUP**: Sets the display into its **Setup** menu to allow the operator to edit **WARNING** and **FAULT** limit values for each parameter monitored by the HTU. See Section 4.2.4, below.

" **CANCEL**: When depressed, allows the operator to abort any changes made to a display parameter and automatically display the previous menu level.

" **▼**: Each time this button is depressed, the next step down the menu is displayed; also used in **SETUP** menu to decrease parameter **TRIP** values, change display units (English or Metric) or edit **NORMAL** display parameters.

" **ENTER**: Use by operator to confirm acceptance of existing or revised parameter values and automatically advances the display to the next menu level.

" **▲**: Each time this button is depressed, the previous menu step is displayed; also used in **SETUP** menu to increase parameter **TRIP** values, change display units (English or Metric) or edit **NORMAL** display parameters.

The purpose of this mode is to display the values of selected parameters in order to be certain they are in proper range. To enter this mode, press the **Status** button. The display will list real time parameter values for:

FLOW RETURN 1  
FLOW RETURN 2

Press the down-arrow key again and the display will show parameter values for

FLOW RETURN 3  
FLOW RETURN 4

Press the down-arrow key again and the display will show parameter values for

FLOW RETURN 5  
FLOW RETURN 6

Press the down-arrow key again and the display will show parameter values for

FLOW RETURN 7  
FLOW RETURN 8

Press the down-arrow key again and the display will show parameter values for

PRIMARY FLOW  
FLOW - FACILITY

Press the down-arrow key again and the display will show parameter values for

TEMPERATURE  
PRESSURE

Press the down-arrow key again and the display will show parameter values for

RESISTIVITY

Press the down-arrow key again and the display will show parameter values for

WARNING LIST  
(- MESSAGE -)

NOTE: Any active warnings will be displayed one at a time on the *MESSAGE* line; press the down –arrow to step through each active warning. “NO MESSAGES” will be display if no warnings have been detected.

Press the down-arrow key again and the display will show parameter values for

FAULT LIST  
(-MESSAGE-)

NOTE: Any active faults will be displayed one at a time on the *MESSAGE* line; press the down –arrow to step through each active fault. “NO MESSAGES” will be display if no faults have been detected.

## 4.2.2 NORMAL Menu

As defined above, this display automatically scrolls between two sets of parameters, once every five seconds. This allows the operator to periodically monitor and record the four most important parameters without having to touch a keypad button. The **factory default** parameters are **FLOW SUPPLY** and **PRESSURE** on one display page, and **TEMPERATURE** and **RESISTIVITY** on the other page. The operator can change the parameters displayed using the procedures defined below in Section 4.2.4, SETUP Menu, subsection on **Display**.

## 4.2.3 CONTROL Menu

Control Menu allows the operator to select between one of two control modes, i.e., either Remote Control or Local Control. To access this menu, press the **Control** button.

**NOTE:** While operating in the CONTROL menu, the HTU controller will allow up to three (3) minutes between keypad button operations before automatically reverting back to the NORMAL display menu.

Depending on the previous mode setting, the resulting display will be either

```
REMOTE CONTROL <
LOCAL CONTROL
PUMP CONTROL
```

For Remote Control Mode, or

```
REMOTE CONTROL
LOCAL CONTROL <
PUMP CONTROL
```

For Local Control Mode.

The left-arrow points to the currently-selected choice. Pressing either of the arrow keys steps it to the next choice.

**NOTE:** In almost all cases, you may use either the up-arrow key or the down-arrow key. The only difference is the direction in which you cycle through the choices.

Press **ENTER** button to accept the newly selected control mode.

**NOTE:** The HTU must be in LOCAL CONTROL mode in order to control pump actuation using the **PUMP ON** and **OFF** buttons on the front control panel.

## 4.2.4 SETUP Menu

The SETUP menu allows the operator to view and edit values and display settings.

**To access the SETUP menu, the operator is required to enter a 3-digit authorization code (202); SETUP is the only mode that requires this.**

**NOTE:** While operating in the SETUP menu, the HTU controller will allow up to three (3) minutes between keypad button operations before automatically reverting back to the NORMAL display menu.

### Entering the Authorization Code (202):

1. Press the button labeled **SETUP**.
2. The display will show three 0's with the leftmost 0 underlined (000).  
Press the up-arrow two times to display the number 2 in the left-most position. Then press **ENTER**.  
Pressing **ENTER** will both accept whatever value was chosen for the leftmost digit and will move the underline to the middle digit. (200)
3. Press **ENTER** to accept the zero value in the middle digit position. The display should now show: (200).
4. Perform Step (2) for the third digit. Pressing **ENTER** will remove the underline, indicating that the code "202" has been accepted.

Once accessed, the up or down arrow can be used to find that SETUP consists of four main menus; i.e., UNITS, NORMAL DISPLAY, TRIP POINTS, and MESSAGES. Each menu is described below.

**UNITS** – Operator can select between English and Metric units to be displayed for each individual parameter; e.g., one can choose either °C or °F for temperature measurements; see **UNITS** flow chart in Appendix A-1.

**NORMAL DISPLAY** – Operator can select the four parameters to be listed when the **NORMAL** display menu button is depressed; see **NORMAL DISPLAY** flow chart in Appendix A-2.

**TRIP POINTS** – Allows operator to edit both **WARNING** and **FAULT** trip values for each parameter, as well as perform electronic calibration (slope, intercept and hysteresis) of each transducer on board the HTU; hysteresis values are used to prevent nuisance tripping that result from crossing of trip levels due to insignificant physical and electronic noise during operation of the HTU; see **TRIP POINTS** flow chart in Appendix A-3. **Factory default WARNING and FAULT trip values** are defined in Appendix A-4.

**MESSAGES** - Allows operator to view and clear any **Warning** or **Fault** messages that have been detected by the HTU control system; see **MESSAGES** flow chart in Appendix A-5.

### 4.3 Start-up Procedure

Before reading this section, first confirm that the HTU installation fully complies with the procedures defined in chapter 3, INSTALLATION – HTU.

The following sequence of steps is used to initialize the microprocessor-based control system:

1. Verify BPR valve is fully open; see procedure at end of section 3.3 for details.
2. Toggle switch on MAIN BREAKER (see Figure 4.1) upward to the ON position; verify that the green MAIN POWER ON LED is illuminated.
3. Press the POWER ON RESET button and observe the following sequence:
  - 3a. All keypad LEDs will light momentarily.
  - 3b. Then the Liquid Crystal Display (LCD) will successively display: POWER ON RESET, software version number, INITIALIZING FROM EEPROM, before returning to a NORMAL display.
  - 3c. The NORMAL LED should be illuminated (green); all three others OFF.
4. Establish Facility supply water flow.
5. Press the pump ON button to energize the pump motor and begin Primary coolant flow.
6. Allow about five minutes for the system to come to a steady state.
7. Check the front panel indicators for either a **DI FLOW WARNING** or a **LEAK WARNING**.
8. Verify that display values for FLOW SUPPLY, PRESSURE, TEMPERATURE, RESISTIVITY meet process tool requirements for Primary coolant supply conditions.
9. Adjust the Back Pressure Regulator (BPR) valve as defined in Section 1.6.2 as necessary to achieve desired values for FLOW SUPPLY and PRESSURE.
10. Determine cause of each Fault and/or Warning message that may be encountered during start-up, before clearing any such message; see **MESSAGES** flow chart in Appendix A-5.

### 4.4 Shut Down Procedure

1. Verify that process tool has completed its process run and that the process tool host controller has switched back from REMOTE CONTROL mode, to LOCAL CONTROL mode (i.e., **LOCAL CONTROL** LED on HTU front panel will illuminate green color when active).
2. Press the **PUMP OFF** button to remove power from the pump and stop Primary coolant supply flow to the process tool.
3. Toggle the front panel **MAIN BREAKER** switch down to the OFF position.
4. Shut-off the dedicated facility main disconnect to remove main power source into HTU.
5. Shut-off all Facility Supply water flow to the HTU.

### 4.5 AC Power Distribution

A diagram describing the AC Power Distribution is given in Appendix B.

## 4.6 Microprocessor Controls

This controls grouping is located behind the front panel controls, within the HTU electrical control enclosure; it occupies the left half of that enclosure. This group consists of all low voltage DC and some 24Vac control circuitry. Components include the microprocessor pc board, A/D board, Interface board, Leak Detector board, Resistivity board, and Host Communication Interface board (RS-485 and/or DeviceNet).

## 4.7 Host Interface Communications

The HTU is equipped the following with three communications interface options; i.e., Analog, RS-485, and DeviceNet. All host interface connectors are located on the bottom side of the electrical controls enclosure.

The **Analog interface** (via connectors P1, P2, P3, P4) has been designed and verified by BOC Edwards to comply with current HTU specification entitled, Applied Materials “PVD 200mm Heat Exchanger Functional Specification” P.N. 0190-70092 Rev.-PD1 (issued – 11/12/99).

Optional additional analog communications via **Analog Adapter Plate** connectors R<sub>1</sub> through R<sub>8</sub> (Amp connectors).

The **DeviceNet communications interface** (via 5-pin MicroDIN connector) was designed to conform to Applied Materials “Functional Specification, PCB, DNet Communications, PVD Hx”, P.N 0190-00122 Rev. E1 (issued 11/12/99).

## 4.8 Shut Down Procedure

1. Verify that process tool has completed its process run and that the process tool host controller has switched back from REMOTE CONTROL mode, to LOCAL CONTROL mode (i.e., **LOCAL CONTROL** LED on HTU front panel will illuminate green color when active).
2. Press the **PUMP OFF** button to remove power from the pump and stop Primary coolant supply flow to the process tool.
3. Toggle the front panel **MAIN BREAKER** switch down to the OFF position.
4. Shut-off the dedicated facility main disconnect to remove main power source into HTU.
5. Shut-off all Facility Supply water flow to the HTU.

## 4.9 AC Power Distribution

A diagram describing the AC Power Distribution is given in Appendix B.

**(END OF CHAPTER 4)**

## 5. MAINTENANCE

***IMPORTANT NOTICE*** - This section contains instructions to enable the operator to properly care for the HTU. The operator must read, understand, and strictly adhere to all **Hazard Warnings** and **Electrical Hazards** defined throughout this manual – failure to do so can result in equipment damage and/or personal injury.

Included also are procedures for **Filling the Reservoir with Coolant, Draining/Bleeding the Reservoir of Coolant; De-ionization Cartridge Replacement; Preventative Maintenance Schedule; and Basic Troubleshooting.**

### 5.1 HAZARD WARNINGS

**Before performing any maintenance procedure on the HTU, the operator must first read and understand the hazard warnings described below, which complement those defined in section 1.4, safety symbols used in this manual.**

<p><b>Warning</b></p> 	Maintenance to the electrical system of the HTU should be performed by qualified personnel only.
---------------------------------------------------------------------------------------------------------	--------------------------------------------------------------------------------------------------

<p><b>High Pressure</b></p> 	Facility Water and the coolant are pressurized within this equipment. Facility Water pressure will depend upon utility supply, but usually is up to 80 psig. The coolant can be at pressures up to 70 psig. Do not open lines with pressure present.
---------------------------------------------------------------------------------------------------------------	------------------------------------------------------------------------------------------------------------------------------------------------------------------------------------------------------------------------------------------------------

<p><b>Eye Protection</b></p> 	Leakage or failure of high pressure fluid plumbing circuits may cause injury or irritation of the eyes. Eye protection should be worn when working with fluid systems.
------------------------------------------------------------------------------------------------------------------	------------------------------------------------------------------------------------------------------------------------------------------------------------------------

<p><b>Hand Protection</b></p> 	Hot fluids and surfaces can cause injury or irritation of the hands. Hand protection should be worn when working with these fluid systems.
-------------------------------------------------------------------------------------------------------------------	--------------------------------------------------------------------------------------------------------------------------------------------

<p><b>Electric Shock</b></p> 	<p>Ensure that all electrical power has been removed and the main circuit breaker has been turned off prior to opening the front panel electrical controls cabinet. The EMERGENCY OFF circuit (EMO) does not disconnect all power from the electrical controls cabinet.</p> <p>Extreme caution must be observed if performing maintenance operations with the front panel electrical controls cabinet door open.</p>
----------------------------------------------------------------------------------------------------------------	----------------------------------------------------------------------------------------------------------------------------------------------------------------------------------------------------------------------------------------------------------------------------------------------------------------------------------------------------------------------------------------------------------------------

<p><b>Hot Surfaces</b></p> 	<p>Pump motor surfaces can attain temperatures up to 80 °C. Circulating fluid lines can attain temperatures as high as 60 °C.</p> <p>Caution must be observed to avoid contact with hot surfaces.</p>
--------------------------------------------------------------------------------------------------------------	-------------------------------------------------------------------------------------------------------------------------------------------------------------------------------------------------------

**NOTE:** “CAUTION - Heavy Object” label is found on only three HTU components; i.e., the reservoir, heat exchanger, and pump. This **caution must be observed** during all service repair or replacement procedures that may require moving or lifting of these components. These components require two (2) people to lift.



## 5.2 Electrical Hazards

Table 5.1 gives the classifications of electrical hazards. This number indicates the severity of the hazard as defined by SEMI S2-93.

**Table 5.1: Electrical Hazards Classification**

Classification	Description	Comment
Type 1	Equipment is fully de-energized	None called out
Type 2	Equipment is energized. Live circuits are covered or insulated. Work is performed at a remote location to preclude accidental shock.	None called out
Type 3	Equipment is energized. Live circuits are exposed and accidental contact is possible. Potential exposures are less than 30 volts RMS, 42.2 volts peak, 240 volt-amperes, 20 Joules. (See NFPA 79-14.3, IEC 204, UL 1950 & 1262, IEC 950.)	Called out as Type 3
Type 4	Equipment is energized. Live circuits are exposed and accidental contact is possible. Potential exposures are greater than 30 volts RMS, 42.2 volts peak, 240 volt-amperes, 20 Joules or radio frequency (rf) is present.	Called out as Type 4
Type 5	Equipment is energized and measurements and adjustments require physical entry into the equipment, or equipment configuration will not allow the use of clamp-on probes.	None called out

## 5.3 Filling the Reservoir with Coolant

The HTU coolant system was designed specifically for de-ionized water use only.

### ***CAUTION – ADD DE-IONIZED WATER ONLY TO RESERVOIR.***

<p><b>Warning</b></p> 	<p>Keep face and eyes away from the area above the HTU top cover sink during removal/replacement of reservoir Fill Plug.</p> <p>Always remove/replace the fill plug <b>SLOWLY</b> to avoid facial contact with moving reservoir level indicator – at higher reservoir water levels, the top end of the reservoir level indicator will have a tendency to be propelled upward above the top cover surface.</p>
-----------------------------------------------------------------------------------------------------------	---------------------------------------------------------------------------------------------------------------------------------------------------------------------------------------------------------------------------------------------------------------------------------------------------------------------------------------------------------------------------------------------------------------

### **Procedure**

1. Verify that Reservoir Drain Valve is in closed position.
2. Unscrew the plastic Fill Plug (item 15, Figure 3.1). **SLOWLY** remove Fill Plug from sink Fill Port.
3. Remove level indicator (item 16, Figure 3.1).
4. Add 25 gallons of de-ionized water to reservoir.
5. Reinstall level indicator and Fill Plug.
6. Wipe dry all water spilled on outside of HTU and/or floor surfaces.

## 5.4 Draining/Bleeding the Reservoir

All coolant (D.I. water) must be drained from HTU reservoir before attempting to move/roll across floor, during service and repair, or for shipping and storage purposes.

*Note: The HTU pump must be de-energized/ shut off during draining procedure. All electric power must be removed from the unit.*

It may be necessary to bleed a portion of the coolant from the HTU reservoir to correct an overfill condition.

*Note: The unit may continue running during the bleeding procedure.*

Follow the procedure below whenever it becomes necessary to drain or bleed the system.

<b>Extreme Temperature</b> 	Coolant temperature could reach +60 °C during extreme operating conditions. Hot fluid can cause burns. Coolant should be at ambient temperature before handling.
---------------------------------------------------------------------------------------------------------------------	---------------------------------------------------------------------------------------------------------------------------------------------------------------------

### Procedure

1. Verify that the sink vent hole located on the top of the HTU is open to ambient atmosphere; remove as necessary any obstructions.

**NOTE:** Steps 2 and 3, below, only apply to installations that have not yet been equipped with external Facility Drain plumbing required to comply with SEMI S2-93A secondary containment standards; refer to Section 3.3, Installation Procedure, Overflow/Reservoir Drain Line in this manual.

2. Select and fasten (hand-tight) an appropriate adapter fitting to Drain Port (1/2"-14 NPT female thread size) located on lower front center panel of HTU.
3. Place an appropriate container beneath the drain valve; or install hose line from unit to near facility drain.
4. Perform step 5a to drain/empty entire contents of reservoir – HTU pump must be deenergized. Perform step 5b to remove excess /reduce coolant level in reservoir – HTU pump can be operated during step 5b to establish the desired operating water level in the reservoir.
  - 5a To empty the reservoir, remove power to the HTU. Next, open the lower front access door, then turn the valve handle marked “drain valve” (located in reservoir drain plumbing along lower right-side of HTU) to the open position; allow the unit to drain until all coolant has been removed. Close the reservoir drain valve upon completion.
  - 5b To correct an overfill condition, open the lower front access door, then turn the valve handle marked “drain valve” (located in reservoir drain plumbing along lower right-side of HTU) to the open position; drain the reservoir until the reservoir level indicator is at desired depth. Close the reservoir drain when desired level is attained.

## 5.5 De-ionization (DI) Cartridge Replacement

The cartridge should be changed whenever the “Resistivity Trip Low” warning condition has been detected by the HTU controller; refer to section 4 , OPERATION, for description of Front Panel Controls; refer to Appendix A-4 for listing of Factory Default Parameter Values, Trip Points - Note that actual Trip Point Value is user selectable and may deviate from the Factory Default value depending upon individual customer needs and practices. In addition, an illuminated (amber) “DI FLOW WARNING” indicator on the front control panel could be caused by a clogged DI cartridge, which would then warrant replacement; see Section 1.7.3., “De-ionization Bypass Loop”, in this manual.

*Note: The HTU may continue running during the DI cartridge replacement procedure.*

### Required Tools & Equipment

Safety goggles, ¼-inch nut-driver, drip-pan (about 1-liter capacity), new DI cartridge (Barnstead P.N. 8901), Quick Release Tool (BOCE P.N. P53260200; equipped with each HTU prototype)  
Padlock and key (to be provided by customer to lock isolation ball valve labeled “V1”, prevent unintended release of water from unit).

### Procedure

1. Open the lower front access door; the DI cartridge is mounted on the inside surface of that door. Please note the following:
  - 1a. Direction of water flow through the cartridge is IN the bottom (purple-colored end ) and OUT the top (white-colored end). The cartridge-end of both hoses are held in place close to the cartridge body by the nylon hook-and-loop cartridge strap.
  - 1b. Flow arrows and labeling are provided on each of the two hose lines IN and OUT of the cartridge.
  - 1c. The two (2) 3/8” plastic plugs mounted to the upper left of the cartridge are to be used during cartridge replacement to prevent open end of the IN and OUT hoses from leaking on floor.
  - 1d. The Quick Release tool (blue plastic, Y-shaped) is fastened by chain to same bracket used to mount the 3/8” plastic plugs, above. The tool itself when not in use is stored loosely within cartridge mounting bracket, and retained in place by the black nylon hook-and-loop cartridge strap.
  - 1e. The as-installed orientation of pre-formed hose elbows that clamp to both IN and OUT barb fittings on cartridge must be such that the inlet flow enters from the left, and the outlet flow exits to the right. This orientation must be maintained to ensure proper assembly during new cartridge installation.
2. Position a drip-pan on the floor beneath the old cartridge.
3. Close the stainless steel ball valve labeled “V1” and **lock in closed position** (padlock to be supplied by customer).

<p><b>Caution</b></p> 	<p>Failure to lock valve “V1” in closed position during DI cartridge replacement procedure could result in unintended loss of de-ionized water from the coolant system which could cause damage to the equipment, associated equipment and process.</p>
---------------------------------------------------------------------------------------------------------	---------------------------------------------------------------------------------------------------------------------------------------------------------------------------------------------------------------------------------------------------------

4. Unfasten the nylon hook-and-loop cartridge strap from around the upper half of the old cartridge.
5. Use the Quick Release tool to depress collet on rigid plastic elbow fitting closest to the pre-formed hose elbow clamped to IN and OUT ends of the old cartridge. Capture any water draining from old cartridge in drip pan.
6. Remove old cartridge (with pre-formed hose elbows still attached) from cartridge mounting bracket. Use the ¼” nut driver to unfasten hose clamp closest to each end of the old cartridge; remove each pre-formed hose elbow assembly from old cartridge and save.
7. Properly dispose of old cartridge.
8. Re-assemble pre-formed elbow assembly to both ends of new cartridge; final orientation of these hose elbows must be as defined in step 1e, above.
9. Re-install cartridge with pre-formed hose elbows in cartridge mounting bracket.
10. Re-install IN and OUT hose lines to tube stub end of respective pre-formed hose elbow assembly.
11. Re-fasten the black nylon hook-and-loop cartridge strap around the upper half of the old cartridge. Make sure to include both the IN hose to cartridge and Quick Release tool/chain assembly within the strap loop.
12. Unlock and open ball valve “V1”; verify that Front Panel indicator “DI Flow Warning” is no longer illuminated.
13. Allow unit to operate until actual resistivity value displayed on Front Panel LCD meets or exceeds the low limit trip point setting. Then, enter SETUP menu, Messages, Warning List using Front Panel Keypad to erase Resistivity Trip Low” from active Warning list; see Appendix A-5.
14. Verify that there are no active Warnings or Fault conditions in STATUS menu or on front panel indicators before allowing the HTU to operate unattended.

## 5.6 Preventative Maintenance Schedule

Table 5.2 shows the maintenance required to keep the HTU in good working order. Failure to follow this schedule may result in degradation of system performance.

Frequency	Operation	Hazard
As-needed	Replace DI Cartridge	(Type 2)
Monthly	Check coolant level	(Type 2)
Semi- annually	Verify system status (front panel control indicators)	(Type 2)
	Coolant leak check (visual inspection of all plumbing)	(Type 2)
	Facility Water leak check (visual inspection of all plumbing)	(Type 2)
	Main Breaker “CB1” functional check (depress test button to verify trip open) For models W990100000 and W990000000	(Type 4)
	Integral Starter “K2” functional check (depress test button to verify trip open)	(Type 4)
Annually	Clean Reservoir internal surfaces	(Type 1)

Table 5.2 Preventative Maintenance Schedule

The HTU electrical controls are equipped with circuit breakers and replaceable fuses to ensure that the unit will safely de-activate in the event of a circuit overload. Table 1.1 of Section 1.4, SAFETY FEATURES, in this manual includes a functional description of all reusable circuit protectors. The AC transformer (“T1”) and DC power supply (“PSU1”) each have both primary-side and secondary-side fuse protection. Table 5.3, below, describes both voltage and current ratings for each replaceable fuse found inside the HTU electrical control box.

(\* Label Nomenclature is same here as for Symbols used in Appendix-B, Power Distribution Schematic)

(\*\* High Voltage-side is to right of center partition plate; Low Voltage-side is to left of center partition plate)

<b>Component Label *</b>	<b>Location in Electrical Box **</b>	<b>Protective Function</b>	<b>Voltage Rating</b>	<b>Amperage Rating</b>
F1	High Voltage-side, on T1, top-mounted	T1, Primary-side	600V	1/2A
F2	High Voltage-side, on T1, top-mounted	T1, Primary-side	600V	1/2A
F3	High Voltage-side, to left of TB1	PSU1, Primary-side	250V	1/2A
F4	High Voltage-side, to left of TB2	Primary-side of PSU1	250V	1/2A
F5	Low Voltage-side, to left of TB2	+24Vdc Supply from ENDURA tool	250V	1/8A
F6	Low Voltage-side, to left of TB2	+15Vdc Supply from ENDURA tool	250V	1/8A
F7	Low Voltage-side, to left of TB2	-15Vdc Supply from ENDURA tool	250V	1/8A
F8	High Voltage-side, on T1, top-mounted	T1, Secondary-side	500V	2A

Table 5.3: Replaceable Fuses found in HTU

**CAUTION: Whenever performing corrective or preventative maintenance on the HTU-108 follow all stated precautions in Section 5 of this instruction manual**

<b>Indicator</b>	<b>Possible Causes</b>	<b>Actions</b>
<b>Main Power ON light is not illuminated</b>	No Power to the HTU 108	Check that the facility power is connected to the HTU-108 in accordance with the installation procedure.  Verify that the facility circuit breaker to the HTU-108 is on.  Ensure that the tool EMO is not activated.  Check if the HTU-108 circuit breaker (CB1) is in the On position.
	<b>Main Power On</b> lamp requires replacement	Verify that the lamp assembly is receiving 24VAC.  <i>Notify the tool operator prior to opening the electrical cabinet. It will activate the electrical box interlock switch which will shutdown the HTU 108</i>  If there is 24VAC across the lamp terminals then replace the lamp.
	24VAC not present across the <b>Main Power On</b> lamp	Check fuses F1 and F2. (T1 Isolation fuses)  Check the fuse F8.
<b>Keypad indications not present (no display or warning lights)</b>	No power to PSU-1	Check for power on the line side of F3 and F4. If power not present check K1 relay and associated K1 contacts.  Check F3 and F4. (PSU-1 isolation fuses)
	Electrical connections or electrical fault (PSU-1 energized)	Check connections on the rear of the electrical box and connections on PSU-1  Check the ribbon cable connection on the keypad.  Faults associated with the IFB or the A/D board. (contact BOCE for assistance)
<b>No LCD display (Keypad lights illuminated)</b>	Electrical connection	Check the ribbon cable connection between the LCD and the IFB.
<b>Pump Fails to Run (Main power light and keypad displays on, red fault LED on)</b>	Fault condition exists in the pump control circuit.	Check the level in the reservoir and fill if necessary.  Check for water in the base of the HTU-108.  Check if K2 is in the Auto position, reset if necessary.  Check that GFI is on and has not tripped on models W990200000 and W990300000
<b>DI Flow Warning</b>	Pump not running	Normal alarm prior to pump start up due to no flow through system.
	No flow through system with pump running	Check Ball valve V1 is fully open  Check for a blocked DI cartridge  Check for a blocked flow restrictor  Check for a pinched or blocked hose
	Sensor/Electrical	Sensor Fouled, broken reed switch, faulty magnet, replace if damage evident  Check electrical connectors  IFB, CPU or PSU-1 related (contact BOCE for assistance)

<b>Indicator</b>	<b>Possible Causes</b>	<b>Actions</b>
------------------	------------------------	----------------

<b>Reservoir Low Level Warning or Fault</b>	Low level in reservoir	Check reservoir level, fill if necessary. If low level is unexplained check for system leakage.
	System Leak	Drain valve leaking, not fully closed  System leak internal or external to system. (if internal could be accompanied by an leak warning on front panel)
	Sensor/Electrical (If reservoir level is normal)	Sensor float broken or leaking, replace sensor  Check electrical connections  IFB, CPU or PSU-1 related (contact BOCE for assistance)
<b>Leak Warning</b>	Internal Leak	Locate and repair leak
	Sensor/Electrical	Sensor fouled with conductive material, replace if necessary  IFB, CPU, PSU-1 or Leak board related (Contact BOCE for assistance)
<b>Low Resistivity Warning</b>	Resistivity less than the warning setpoint	Replace the DI cartridge.  Verify the desired trip setpoint
	Sensor/Electrical	Probe fouled, internal probe leak, replace if damage evident  Check electrical connections  IFB, A/D, CPU, PSU-1 or Resistivity board related (Contact BOCE for assistance)
<b>Low Flow Warning</b>	Coolant return or facility flow less than trip setpoint.	Check BPR setting, possible pump failure, check for fouling/blockage of lines, increase facility flow not to exceed 30 gallons per minute flow rate.
	Sensor/Electrical	Verify the desired trip setpoint  Replace the flow meter if damage is evident  Check electrical connectors  IFB, CPU, PSU-1, software related (Contact BOCE for assistance)
<b>High Flow Warning</b>	Coolant return or facility flow higher than the trip setpoint	Verify the desired trip setpoint  Check the BPR setting, lower the facility supply flow
	Sensor/Electrical	Faulty reading when in "air purge"  PSU-1, IFB, CPU or software related (Contact BOCE for assistance)
<b>Low Temperature Warning</b>	Temperature lower than the trip setpoint	Verify the desired trip setpoint
	Sensor/Electrical	Sensor fouled with conductive material  Replace sensor if damage is evident  Check electrical connections  IFB, A/D, CPU, Resistivity board or software related (Contact BOCE for assistance)
	Incorrect facility supply temperature or flow rate.	Verify facility flow rate and temperature are within the specifications noted in Chapter 2.

<b>Indicator</b>	<b>Possible Causes</b>	<b>Actions</b>
------------------	------------------------	----------------

<b>High Temperature Warning</b>	Temperature is higher than the trip setpoint	Verify desired trip setpoint Heat Exchanger fouling Excessive tool heat load
	Sensor/Electrical	Open RTD (non conductive fouling) Replace sensor if damage is evident Check Electrical connectors IFB, A/D, PSU-1, CPU, Resistivity board or software related (Contact BOCE for assistance)
	Incorrect facility supply temperature or flow rate.	Verify facility flow rate and temperature are within the specifications noted in Chapter 2.
<b>High Pressure Warning</b>	System pressure higher than the trip setpoint	Verify desired trip setpoint Flow restriction external to the HTU-108 Adjust the BPR valve setting Check for system fouling/blockage
	Sensor/Electrical	Check for mechanical damage to the sensor (pressure shock) replace if damage is evident. Check Electrical connections IFB, A/D, PSU-1 or CPU related (Contact BOCE for assistance)
<b>High Pressure Warning (Continued)</b>	Fouling of BPR or spring failure	Clean or replace the BPR
<b>Unable To Adjust Primary Supply Pressure</b>	Possible broken or blocked valve stem on the BPR	Clean or replace the BPR
<b>Loss of Communication with the tool</b>	Faulty DeviceNet card or connection	Check the connection at the bottom of the electrical cabinet. Check the ribbon cable and connection point at J1 located at the bottom of the electrical cabinet. Check for the proper firmware revision on the DeviceNet card. Replace if necessary. Check if jumper JP1 is installed on the DeviceNet board

**(END OF CHAPTER 5)**

## APPENDIX A-1: SETUP Menu - UNITS Flow Chart

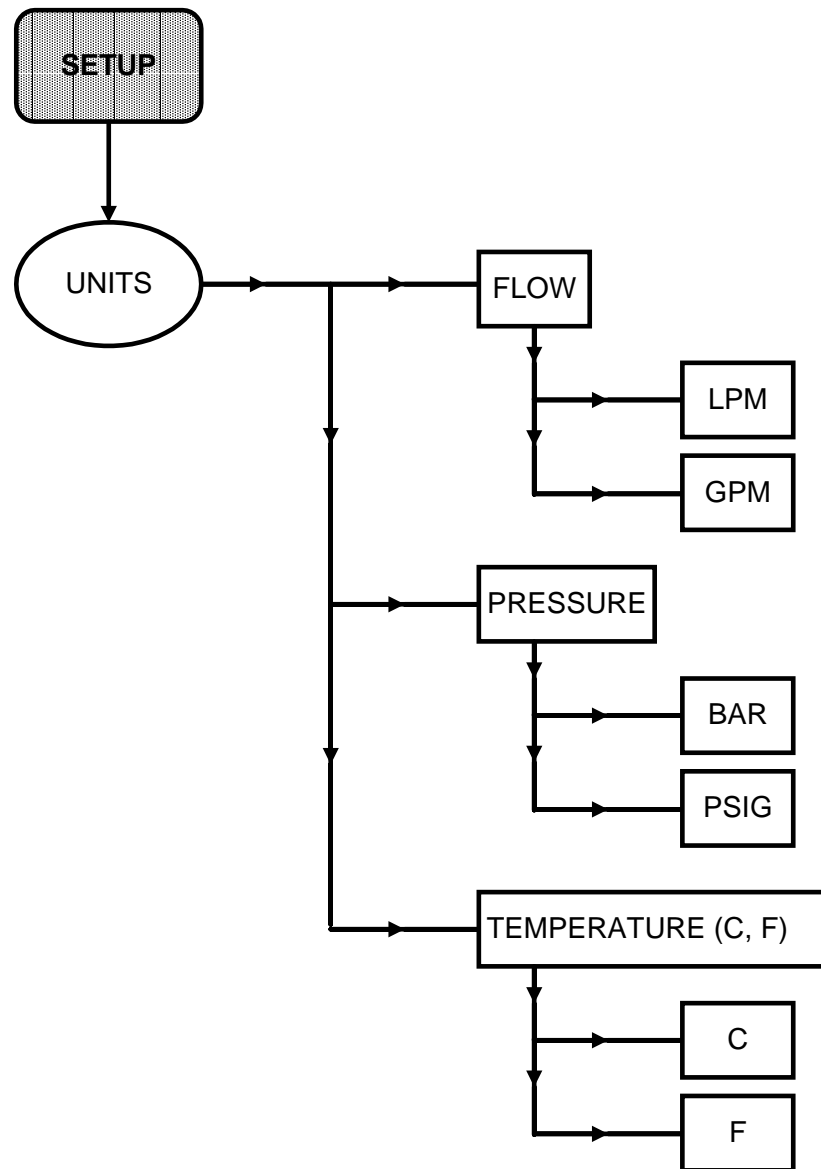

### KEYPAD INSTRUCTIONS:

1. Depress down-arrow button (or up arrow button) to view current units setting.
2. Depress ENTER button to modify current units setting.

**APPENDIX A-2: SETUP Menu - NORMAL DISPLAY Flow Chart**

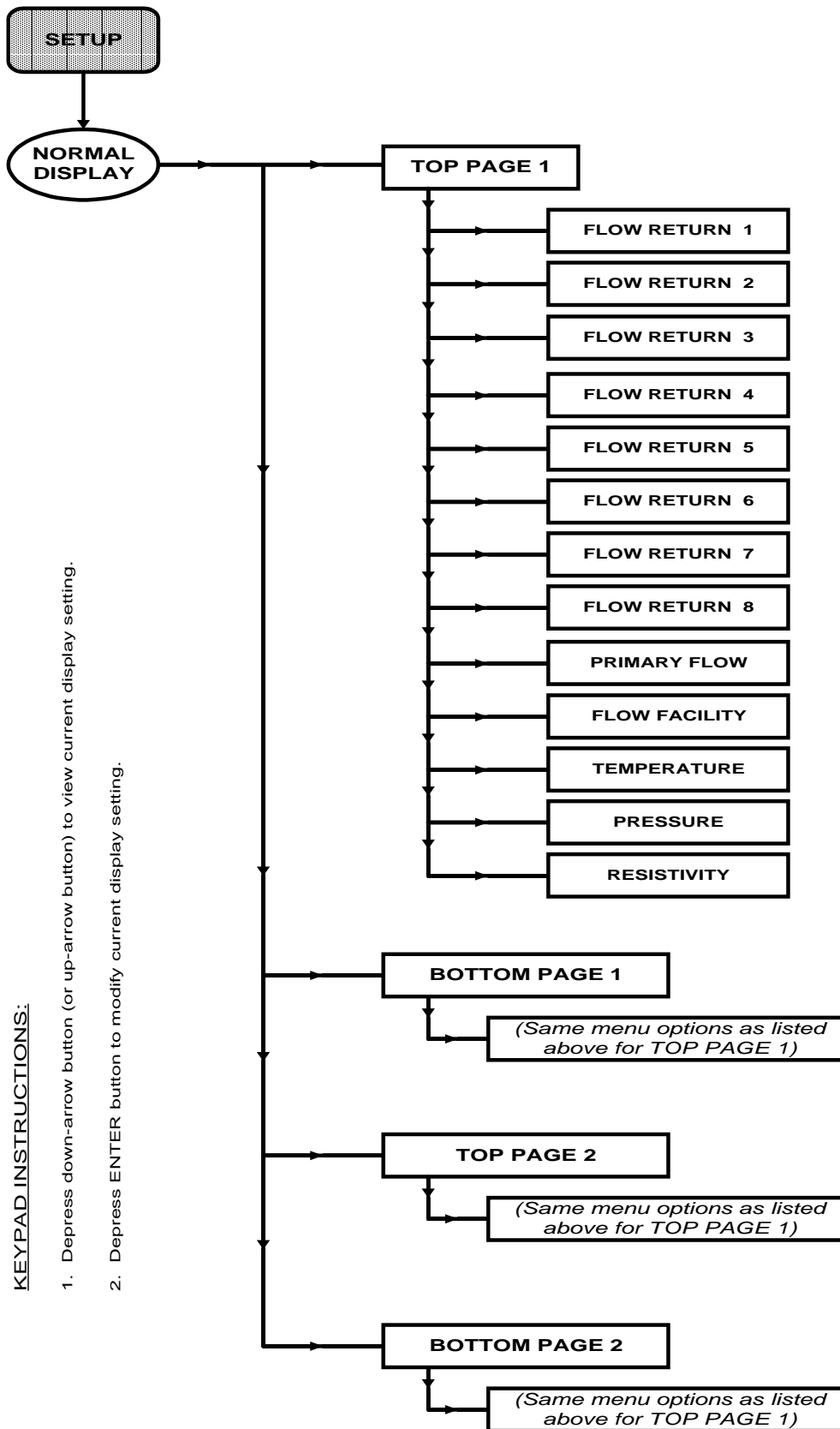

**APPENDIX A-3: SETUP Menu - TRIP POINTS Flow Chart**

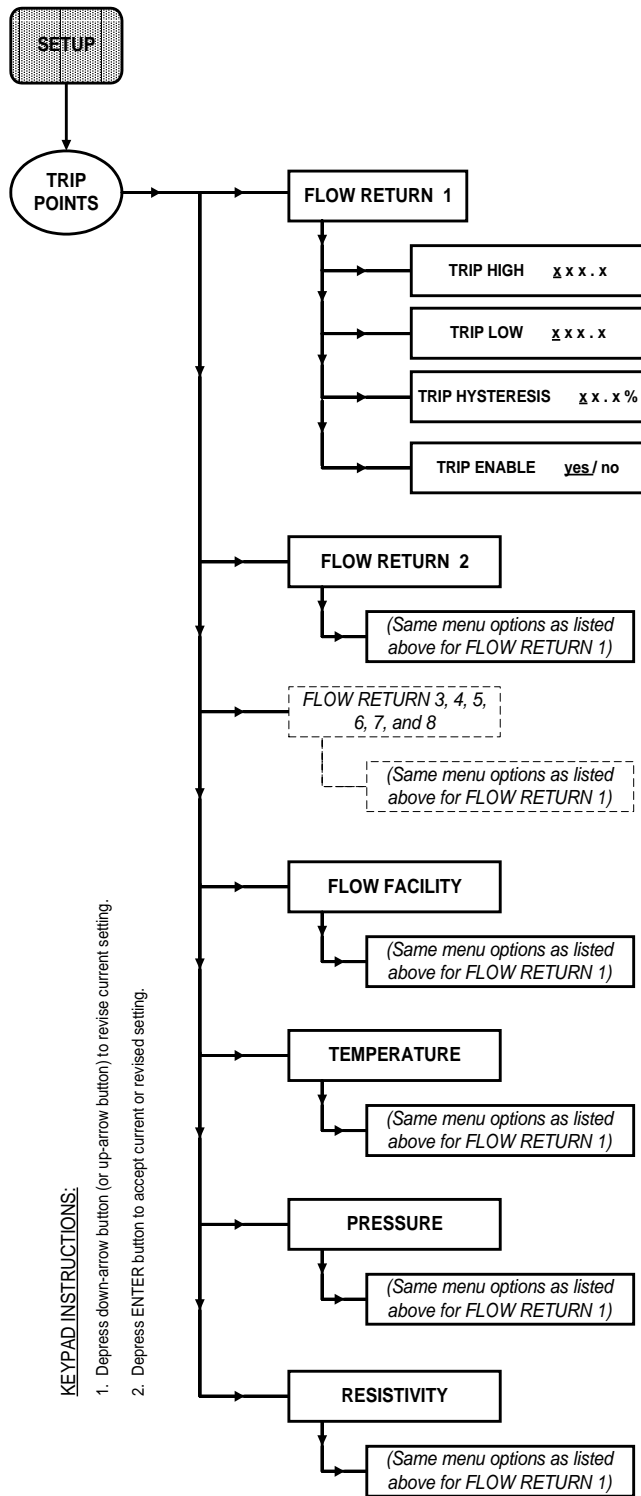

**SETUP Menu –  
Factory Default / Parameter Values**

SETUP SUB-MENU	PARAMETER	FACTORY DEFAULT
UNITS	FLOW	GPM
	PRESSURE	PSIG
	TEMPERATURE	degree-C
NORMAL DISPLAY	TOP PAGE 1	Primary Supply Flow
	BOT PAGE 1	Primary Supply Pressure
	TOP PAGE 2	Primary Supply Temperature
	BOT PAGE 2	Primary Supply Resistivity
TRIP POINTS	Flow trip low	9.4 LPM (2.5 GPM)
	Flow trip hysteresis	1.5%
	FLOW 1 trip enabled	yes
	FLOW 2 trip enabled	yes
	FLOW 3 trip enabled	yes
	FLOW 4 trip enabled	yes
	FLOW 5 trip enabled	yes
	FLOW 6 trip enabled	yes
	FLOW 7 trip enabled	yes
	FLOW 8 trip enabled	yes
	Facility Flow trip high	113.5 LPM (30 GPM)
	Facility Flow trip low	30.3 LPM (8 GPM)
	Facility Flow trip hysteresis	1.5%
	Facility Flow trip enabled	yes
	Pressure trip high	4.48 BAR (65 PSIG)
	Pressure trip low	0.41 BAR (6 PSIG)
	Pressure trip hysteresis	1.5%
	Pressure trip enabled	yes
	Temperature trip high	30°C (86°F)
	Temperature trip low	6°C (43°F)
Temperature trip hysteresis	1.5%	
Temperature trip enabled	yes	
Resistivity trip high	9,000,000 Ohm-cm	
Resistivity trip low	600,000 Ohm-cm	
Resistivity trip hysteresis	1.5%	
Resistivity trip enabled	Yes	

## APPENDIX A-5: SETUP Menu - MESSAGES Flow Chart

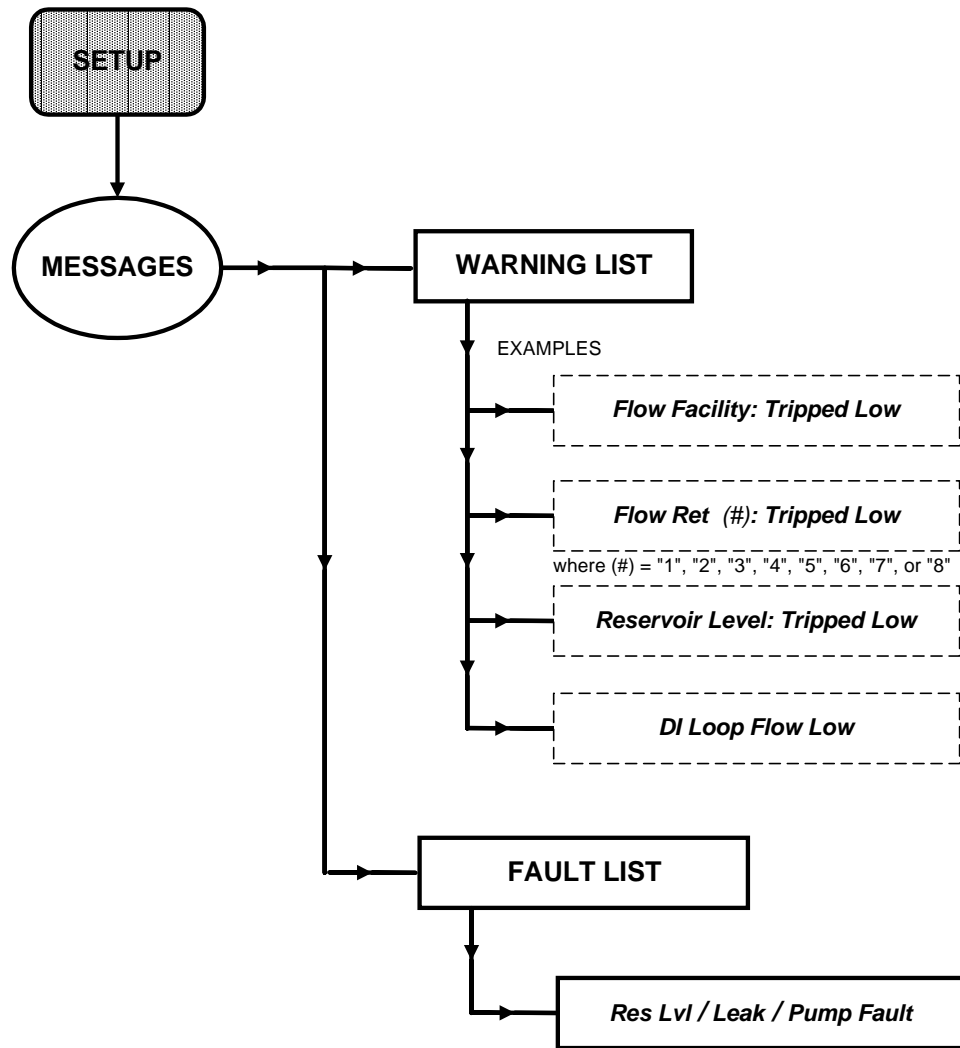

### KEYPAD INSTRUCTIONS:

1. Depress down-arrow button (or up-arrow button) to display the next message.
2. Depress ENTER button to erase the current message and display the next message.

# APPENDIX B-1: Schematic, Power Distribution, HTU Analog

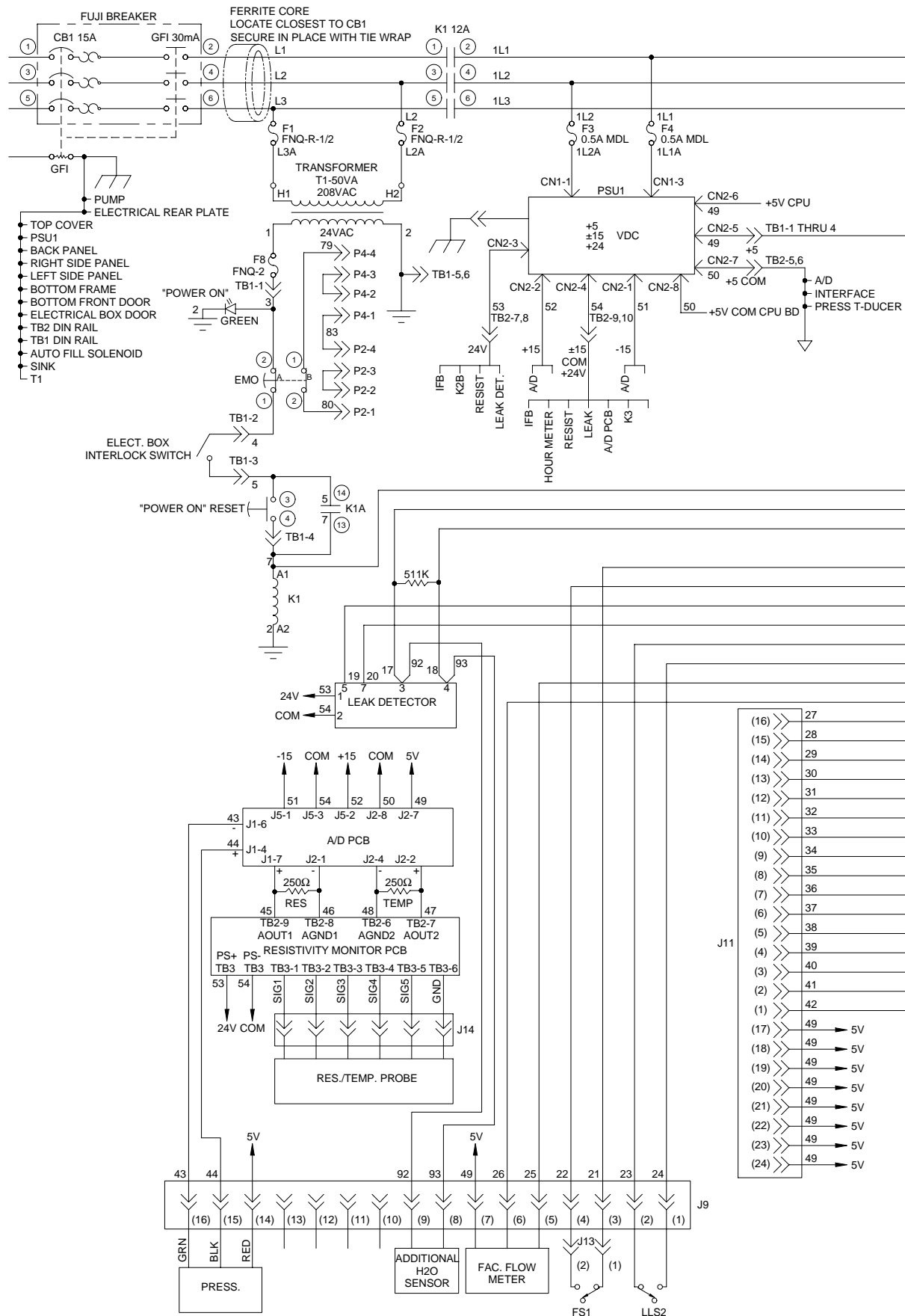



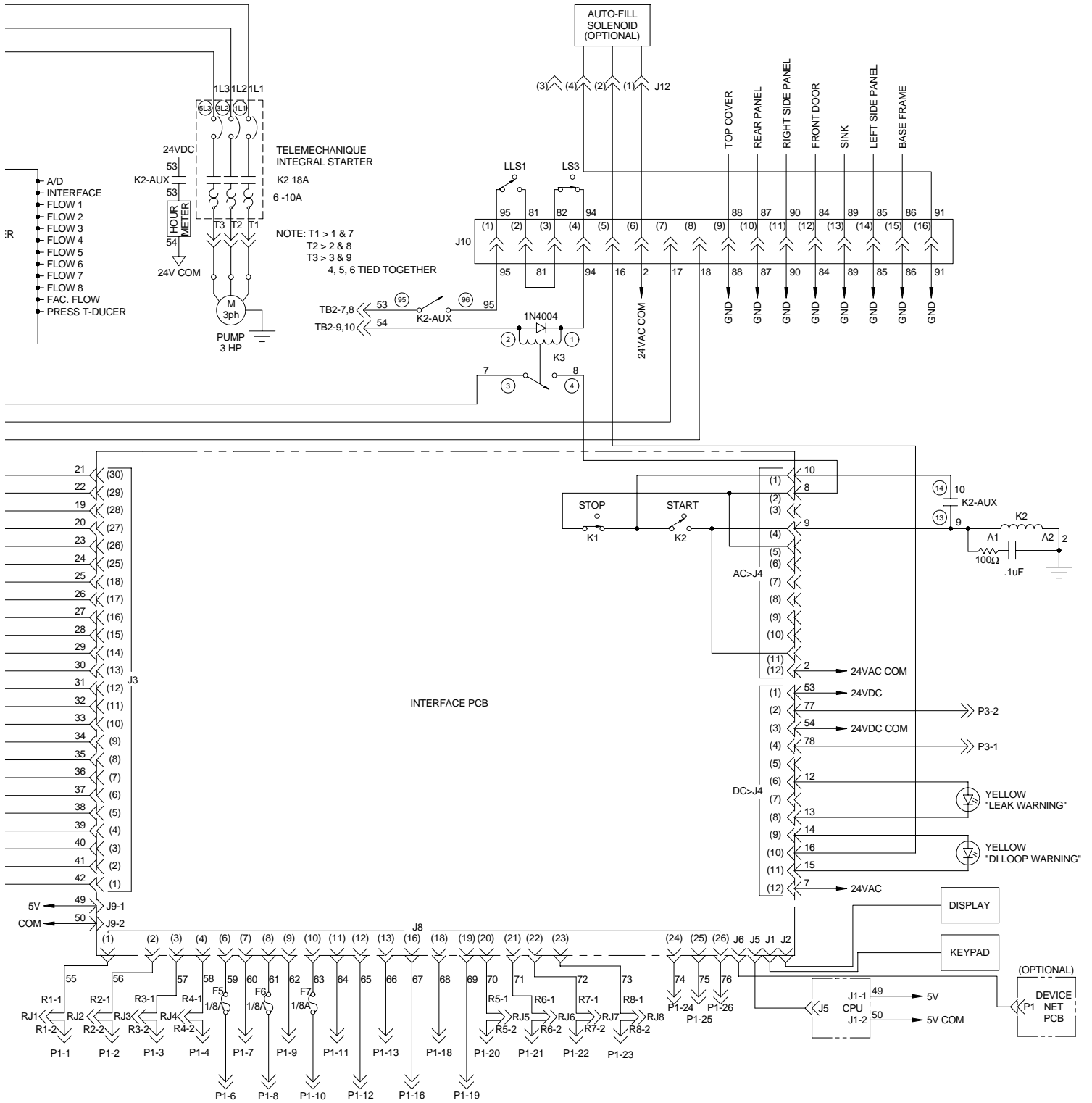





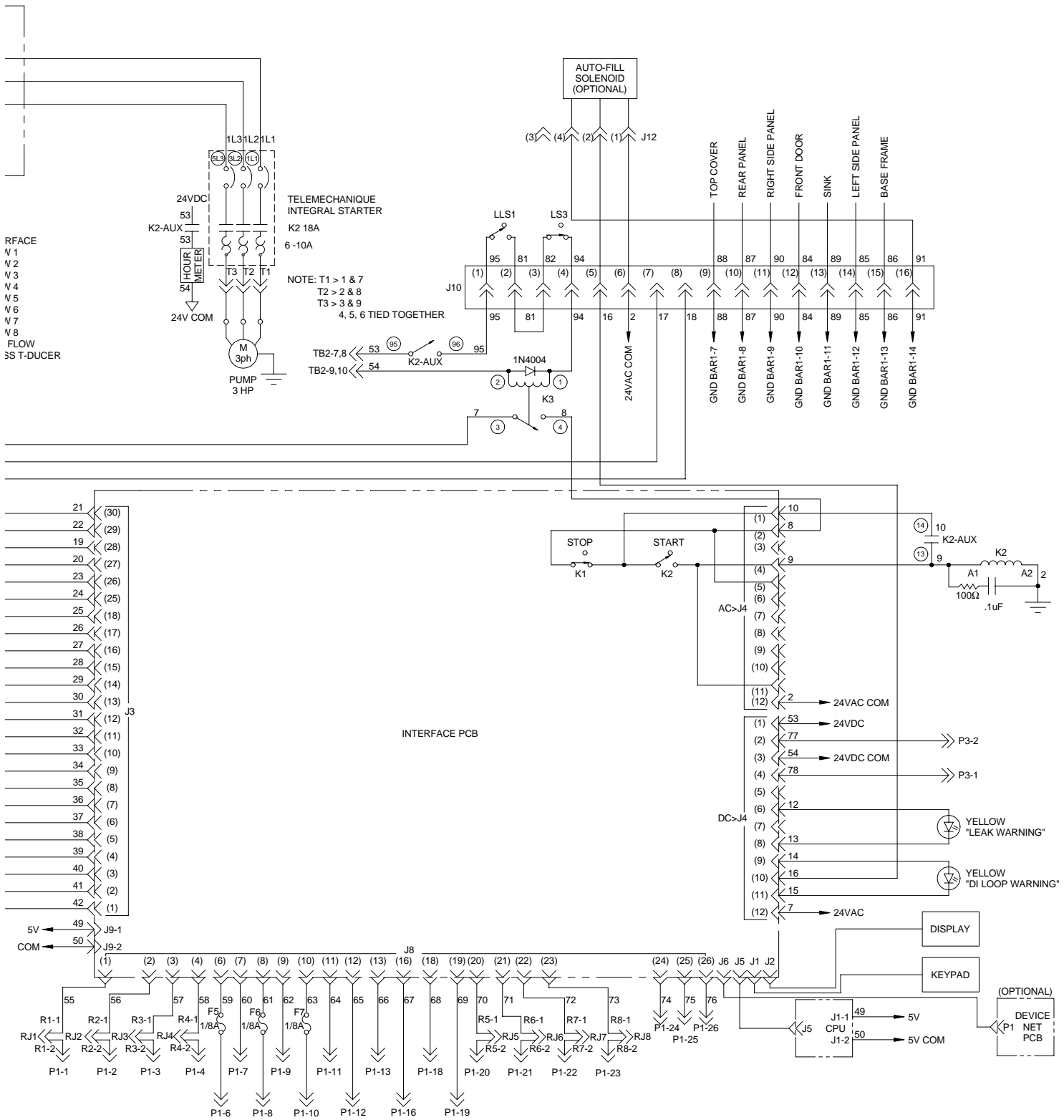

## APPENDIX C: HOST INTERFACE CABLES PIN-OUT TABLES

**NOTE:** Part Numbers for all customer-supplied connector housings and contacts are given in Section 3.4, subsection entitled “Host Interface Cables”.

### Connector P1 I/O

<u>Pin</u>	<u>Signal Type</u>	<u>Function</u>
1	DO	Return #1, Flow Monitor
2	DO	Return #2, Flow Monitor
3	DO	Return #3, Flow Monitor
4	DO	Return #4, Flow Monitor
5		
6		+24 Volts DC Supply
7		24 Volts Common
8		+15 Volts DC Supply
9		15 Volts Common
10		-15 Volts DC Supply
11	AO	Supply Water Temperature (Primary flow)
12		Signal Common
13	DO	Reservoir Level Warning / Facility Flow Output
14		
15		
16	DO	Resistivity of Primary Flow (good/bad)
17	DO	
18	DO	Facilities Flow Monitor
19	DO	Water leak detect
20	DO	Return #5, Flow Monitor
21	DO	Return #6, Flow Monitor
22	DO	Return #7, Flow Monitor
23	DO	Return #8, Flow Monitor
24	DI	Remote ON/OFF
25	DO	Available
26	DO	Low resistivity cartridge flow
27		
28		

## APPENDIX-C, continued...

### Connector P2 EMO & P4 EMO

**NOTE:** The HTU provides normally closed (open on fault) contacts during normal operation between pins 1 and 4.

Pin	Signal Type	Function
1		EMO N.C. - 1
2,3		Jumpered to each other
4		EMO N.C. - 2

### Connector P3 LEAK

**NOTE:** The HTU provides normally open (close on fault) contacts during normal operation between pins 1 and 4.

Pin	Signal Type	Function
1		Leak Detect N.O. - 1
2		Leak Detect N.O. - 2
3-9		(empty)

### DeviceNet 5-Pin Micro Male Connector

**NOTE:** Pin 1 identified using square pad; all other pins use round pads.

Pin	Signal Type	Function
1		Drain
2		V+
3		V-
4		CAN_H
5		CAN_L

### Connector R<sub>1</sub> through R<sub>8</sub>

**NOTE:** Prior to routing to the P<sub>1</sub> connector, the return flow signals #1 through 8 are interrupted and sent to connectors R<sub>1</sub> to R<sub>8</sub>. Jumper plugs are supplied.

Pin	Signal Type	Function
1	DO	Return flow monitor
2	Send signal to P <sub>1</sub>	Retransmit signal to P <sub>1</sub>

Item No.	Accessory Description	Qty. per Assy.
1	Fitting, Return, Male ORS Connector, 5/8" tube with O-ring end seal x 1/2" male NPTF, 316SS <b>BOCE PART NO. P33136300</b>	8
2	Fitting, Return, Male 37-degree Flare Connector, 5/8"-37FLR JIC x 1/2" male NPTF, 316SS <b>BOCE PART NO. P33136400</b>	8
3	Fitting, Male ORS Connector, 1" tube with O-ring end seal x 1" male NPTF, 316SS (qty-1 each used on Primary Sply, Facility Sply & Rtn) <b>BOCE PART NO. P33136500</b>	3
4	Fitting, Male 37-degree Flare Connector, 1"-37FLR JIC x 1" male NPTF, 316SS (qty-1 each used on Primary Supply, Facility Supply, Facility Return) <b>BOCE PART NO. P33136600</b>	3
5	"AUTO-FILL" Valve Assembly, 1/2" Tube OD x 1/2" male NPT 316SS; 8-ft power cable with connector <b>BOCE PART NO. P60206800</b>	1
6	"GOAL POST" Assembly, telescoping, SS; (H-shaped hose rack) (mounts on top cover; used as return hose support bracket) <b>BOCE PART NO. P60206900</b>	1
7	Stabilization Kit, mounting brackets and hardware <b>BOCE PART NO. P60208400</b>	1
8	Male ORS Connection Kit, includes 8 x P33136300 & 3 x P33136500 <b>BOCE PART NO. P60202100</b>	1
9	37-Degree Flare Connector Kit, includes 8 x P33136400 & 3 x P33136600 <b>BOCE PART NO. P60202000</b>	1

Item No.	Service Part Description	Qty per Assy
1	Assembly, Return Flow Meter, 1.5-to-12 gpm, 1/2" Female NPT end connectors, includes signal cable w/crimp-on connectors <b>BOCE Part No. P60206200</b>	8
2	Assembly, Reservoir Level Switch, ("LLS1" and "LLS2") includes cable with crimp-on connectors <b>BOCE PART NO. P60206300</b>	2
3	Assembly, Primary Resistivity Sensor Probe, ("RP/T") 1/2" Male NPT, includes signal cable with connector <b>BOCE PART NO. P43176200</b>	1
4	Transducer, Primary Pressure, ("P1") <b>BOCE PART NO. P43012800</b>	1
5	Assembly, DI Flow Switch, ("FS-1") Includes cable with crimp-on connectors <b>BOCE PART NO. P60206500</b>	1
6	Assembly, Facility Flow Meter, ("FM-F") includes cable leads with crimp-on connectors <b>BOCE PART NO. P60206601</b>	1
7	Fuse, slow blow, Rejection-type, 1/2-amp; "F1" & "F2" (TR1 primary) <b>BOCE Part No. P43131800</b>	2
8	Fuse, slow blow, 1/2-amp; "F3" & "F4" (PSU-1 primary) <b>BOCE Part No. P43130500</b>	2
9	Fuse, slow blow, 1/8-amp; "F5", "F6", & "F7" (24V, +/-15V from host) <b>BOCE Part No. P43131600</b>	6
10	Fuse, slow blow, 2-amp; "F8" (TR1 secondary) <b>BOCE Part No. P43131900</b>	1
11	DI Cartridge Assembly, includes; 1 x Cartridge, D.I. Water, 3/8" hose barb conn.'s (Barnstead P.N. D8901) 2 x Hose Elbow, Heat Formed Reinforced PVC, 3/8" (used on DI cartridge line) 2 x Clamp, worm drive, SS, for 1/2" hose O.D., (used on DI cartridge line) <b>BOCE Part No. P60205200</b>	1
13	Quick Release Tool, (used on DI cartridge line) <b>BOCE Part No. P53260200</b>	1
14	Pump Assembly, Centrifugal (3HP, 2850/3450 rpm, 3ph, 200-208V 50/60Hz) <b>BOCE Part No. P60203900</b>	1
15	Heat Exchanger, copper-brazed 316 SS, (100kW rating) <b>BOCE Part No. P33140300</b>	1
16	Gasket, Teflon (used on Heat Exchanger connector fittings) <b>BOCE Part No. P33116900</b>	4
17	Assembly, Fill Pan Plug, with brass chain leash, (used on sink, unit top cover) <b>BOCE Part No. P60243200</b>	1
18	Pin Extraction Tool (used during instrument service replacement) <b>BOCE Part No. P53260100</b>	1
19	Kit, Board Replacement (CPU Board, A/D Board, Resistivity Board, Interface Board) <b>BOCE Part No. P60217000</b>	1
20	Device Net ard (W00000000 units only) <b>BOCE Part No. P21380600</b>	1

**APPENDIX G: Predicted Thermal Performance Curves**



**Predicted Thermal Performance Curves**



**APPENDIX H: HTU ANALOG ADAPTER PLATE**

VIEWED FROM UNDERNEATH ELECTRICAL BOX

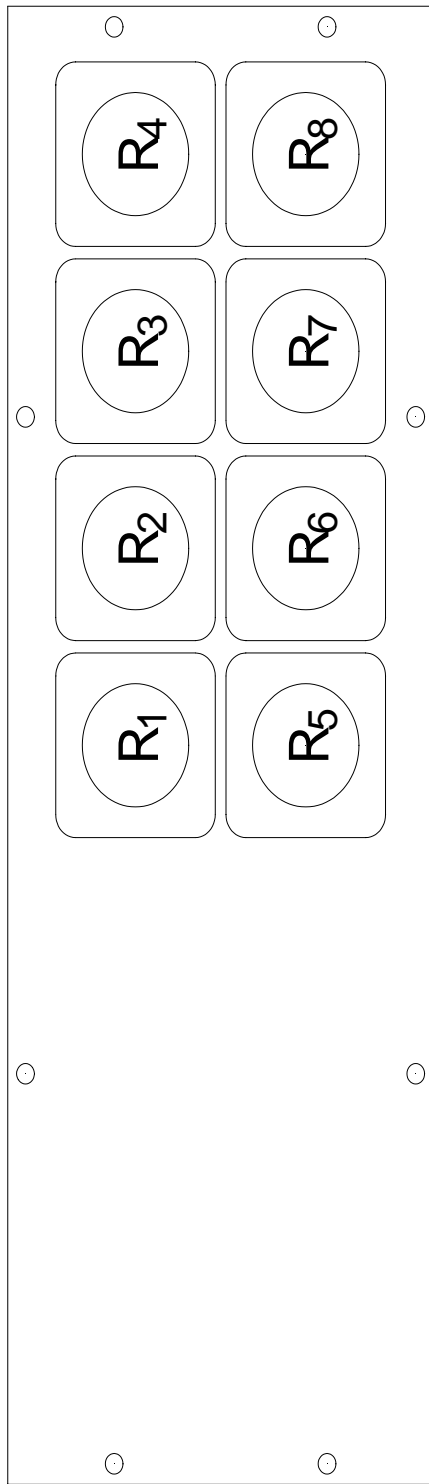

## HTU Field Failure Report



**SECTION 4 : CORRECTIVE ACTION**

Action Taken:
Possible Root Cause:
Corrective Actions:
Comments:

**SECTION 5 : CONTACT INFORMATION**

Print your name: \_\_\_\_\_ Print your job title: \_\_\_\_\_

Telephone number: \_\_\_\_\_ Date: \_\_\_\_\_

Signed: \_\_\_\_\_

**PLEASE FAX COMPLETED FORM TO: GLOBAL HTU PRODUCT SUPPORT ON 978 – 658 7969**

## **Legal notices, limitations and disclaimers**

For a period of twelve (12) months from the date of original shipment to Purchaser, the apparatus and each part of component manufactured by Edward's High Vacuum International (Edwards) is warranted to be free from functional defects in materials and workmanship. The foregoing warranty is subject to the condition that regular periodic maintenance and service be performed or replacements made in accordance with instructions provided by Edwards. The foregoing warranty shall not apply to any apparatus, part, or component that has been repaired other than by Edwards or an authorized Edwards representative or in accordance with written instructions provided by Edwards, that has been altered by anyone other than Edwards or that has been subject to improper installation or abuse, misuse, negligence, accident, or corrosion.

Purchaser's sole and exclusive remedy under the above warranty is limited to, at Edward's option, repair or replacement of defective parts of components or return to Purchaser of the price of the apparatus. The defect must be promptly reported to Edwards or Purchaser must return the part or component with a statement of the observed deficiency no later than seven (7) days after the expiration date of the warranty to the address designated by Edwards, transportation charges prepaid. In the event that Edwards elects to refund the purchase price, the apparatus shall be the property of Edwards and shall be shipped to Edwards at Edward's expense. This Mechanical Warranty shall be void and the apparatus shall be deemed to be purchased AS IS in the event that the entire purchase price has not been paid within thirty (30) days of original shipment of apparatus.

THERE ARE NO EXPRESS OR IMPLIED WARRANTIES THAT EXTEND BEYOND THE WARRANTY HEREIN ABOVE SET FORTH. THERE IS NO PARTICULAR WARRANTY OF MERCHANT ABILITY OR FITNESS FOR A PARTICULAR PURPOSE WITH RESPECT TO THE APPARATUS OR ANY PART OR COMPONENT THEREOF AND NO WARRANTY SHALL BE IMPLIED BY LAW.

Items not of Edwards's manufacture but resold by Edwards are the products of other manufacturers and their warranty, if any, shall apply. THERE ARE NO WARRANTIES OF ANY KIND ON PRODUCTS OF OTHER MANUFACTURERS RESOLD BY EDWARDS EXCEPT THE WARRANTY OF TITLE. AND NO WARRANTIES SHALL BE IMPLIED BY LAW. THERE IS NOT EXPRESS OR IMPLIED WARRANTY OF MERCHANT ABILITY OR OF FITNESS FOR A PARTICULAR PURPOSE WITH RESPECT TO PRODUCTS OF OTHER MANUFACTURERS.

In no event shall the Purchaser be entitled to any special, indirect, or consequential damages.

# BOC Edwards International

## EUROPE

### UNITED KINGDOM

Edwards High Vacuum International  
Manor Royal  
Crawley  
West Sussex RH10 2LW  
Tel: (01293)528844  
Fax: (01 293) 533453

### BELGIUM

Edwards  
Bergensesteenweg 709  
B1600 Sint-Pieters-Leeuw  
Tel: 2 360 3671  
Fax: 2 360 3591

### FRANCE

Edwards SA  
125 Avenue Louis Roche  
92238 Gennevilliers, Cedex  
Tel: (1) 4798 2401  
Fax: (1)4798 4454

### GERMANY

Edwards Hochvakuum GmbH  
Postfach 1 409  
D35004 Marburg  
Tel: 6420 82410  
Fax: 6420 82411

### ITALY

Edwards Alto Vuoto SpA  
Via Carpaccio 35  
20090 Trezzano Sul Naviglio  
Milano  
Tel: 2 4840 2258  
Fax: 2 4840 1638

### SWITZERLAND

Edwards (ECH)  
Postfach  
CH-4104 Obrwil-Basel  
Tel: 61 401 4344  
Fax: 61 401 4352

## AMERICAS

### USA

Edwards High Vacuum International  
One Edwards Park  
301 Ballardvale St.  
Wilmington, MA 01887  
Tel: 508 658 5410  
Fax: 508 658 7969

Edwards High Vacuum International  
Sierra Technology Center  
Building A Suite 120  
3100 Alvin Devane Boulevard  
Austin, TX 78741  
Tel: 512 389 3883  
Fax: 512 389 3890

Edwards High Vacuum International  
550 Sycamore Drive  
Santa Clara, CA 95035  
Tel: 408 946 4707  
Fax: 408 946 8510

### CANADA

Edwards High Vacuum  
3375 North Service Road  
Units B2/B3  
Burlington  
Ontario, L7N 3G2  
Tel: 905 336 9119  
Fax: 905 845 4924

### BRAZIL

Edwards Alto Vácuo  
Rua Benardo Wrona, 222  
Bairro do Limão  
02710 - São Paulo - SP  
Tel: 11 858 0377  
Fax: 11 265 2766

## PACIFIC

### JAPAN

Nippon Edwards KK  
Shuwa Shiba Park Building A-3F  
2-4-1 Shibakoen  
Minato-ku  
Tokyo 105  
Tel: 3 5470 6530  
Fax: 3 5470 6521

Nippon Edwards KK  
Esaka Yodo Building 5F  
16-34 Enoki-cho  
Suita-shii  
Osaka 564  
Tel: 6 384 7052  
Fax: 6 384 7504

Nippon Edwards KK  
508-1 Yomogi-machi  
Kumamoto-shi  
Kumamoto 861-55  
Tel: 96 326 7300  
Fax: 96 326 7302

### HONG KONG

Edwards High Vacuum (Pacific)  
1308 Tower II  
World Trade Square  
123 Hoi Bun Road  
Kwun Tong, Kowloon  
Hong Kong  
Tel: 796 9111  
Fax: 796 9095

### REPUBLIC OF KOREA

Songwon Edwards Ltd  
Sun In Building  
738-41 Panpo-Dong  
Sochu Gu, Seoul  
Tel: 2515 1811  
Fax: 2 515 1818

### TAIWAN

Zimmerman Scientific Co Ltd  
Golden Dragon Building  
8FL No 127  
Fu-Shin South Road  
Section 1, Taipei  
Tel: 2 752 7075  
Fax: 2 771 9415



# BOC EDWARDS

Edwards High Vacuum International is part of BOC Limited

The stripe symbol is a trade mark of The BOC Group