

Vacuum Solutions

Application Support

Service



LEYBOLD VACUUM

GA 01.600/10.02



**PTB**  
SALES

FOR SALES AND SERVICE PLEASE CALL:  
PTB SALES T : 866.332.0500  
F : 626.334.2151  
www.ptbsales.com

DATE SERVICED: \_\_\_\_\_



## TRIVAC<sup>®</sup> E 2

D 5 E / D 10 E / D 16 E

Dual-Stage Rotary Vane  
Vacuum Pump



Operating Instructions

**Contents**

	<b>Page</b>		<b>Page</b>
<b>IMPORTANT SAFETY CONSIDERATIONS</b>	<b>4</b>	<b>3</b>	<b>Checking / Maintenance</b> . . . . . <b>18</b>
<b>1</b>	<b>Description</b> . . . . . <b>6</b>	3.1	Checking the Oil Level . . . . .18
1.1	Principle of Operation . . . . .6	3.1.1	Oil Check . . . . .18
1.2	Supplied Equipment . . . . .8	3.2	Oil Change . . . . .19
1.2.1	Notes on the Oil and how to Order . . . . .8	3.2.1	Disposal of Used Pump Materials . . . . .19
1.3	Accessories . . . . .8	3.3	Cleaning the Dirt Trap . . . . .20
1.4	Technical Data . . . . .9	3.4	Removing and Inserting the Internal Demister . . . . .20
1.4.1	Motor Dependent Data . . . . .9	3.5	Disassembly and Assembly of the Electric Motor . . . . .21
<b>2</b>	<b>Operation</b> . . . . . <b>12</b>	3.5.1	Instructions for the TRIVAC D 5 E - D 10 E . .21
2.1	Installation . . . . .12	3.5.2	Instructions for the TRIVAC D 16 E . . . . .22
2.2	Connection to the System . . . . .12	3.6	Full Maintenance . . . . .23
2.3	Electrical Connection . . . . .13	3.7	Leybold Service . . . . .23
2.3.1	Pumps with AC Motor . . . . .13	3.8	Shelving . . . . .23
2.3.2	Pumps with Three-Phase Motor . . . . .13	<b>4</b>	<b>Maintenance Plan</b> . . . . . <b>24</b>
2.4	Start-Up . . . . .15	<b>5</b>	<b>Maintenance Kits and Repair Sets</b> . . . . . <b>26</b>
2.5	Operation . . . . .15	5.1	Ordering Information for the Maintenance Kits and the Repair Sets . . . . .30
2.5.1	Pumping of Non-Condensable Gases and Vapours . . . . .15	5.2	Ordering Information for the Special Tools . . .30
2.5.2	Pumping of Condensable Gases and Vapours . . . . .16	<b>6</b>	<b>Troubleshooting</b> . . . . . <b>31</b>
2.5.3	Operating Temperature . . . . .16		<b>EC - Declaration of Conformity</b> . . . . . <b>32</b>
2.6	Shut Down / Shelving . . . . .17		
2.6.1	Shut Down through Monitoring Components . . . . .17		
2.6.2	Failure of the Control System or the Mains Power . . . . .17		

We reserve the right to modify the design and the specified data. The illustrations are not binding.



We strongly recommend that you read these Operating Instructions with care so as to ensure optimum operation of the pump right from the start.

### Warning

Indicates procedures that must be strictly observed to prevent hazards to persons.



### Caution

Indicates procedures that must strictly be observed to prevent damage to, or destruction of the pump.

### Figures

The references to diagrams, e.g. (1/2) consist of the Fig. No. and the Item No. in that order.

## Leybold-Service

If a pump is returned to LEYBOLD, indicate whether the pump is free of substances damaging to health or whether it is contaminated.

If it is contaminated also indicate the nature of the hazard. LEYBOLD must return any pumps without a „Declaration of Contamination“ to the sender's address.

### Disposal of Waste Oil

Owners of waste oil are entirely self-responsible for proper disposal of this waste.

Waste oil from vacuum pumps must not be mixed with other substances or materials.

Waste oil from vacuum pumps (Leybold oils which are based on mineral oils) which are subject to normal wear and which are contaminated due to the influence of oxygen in the air, high temperatures or mechanical wear must be disposed of through the locally available waste oil disposal system.

Waste oil from vacuum pumps which is contaminated with other substances must be marked and stored in such a way that the type of contamination is apparent. This waste must be disposed of as special waste.

European, national and regional regulations concerning waste disposal need to be observed. Waste must only be transported and disposed of by an approved waste disposal vendor.

**Caution** The oil for the TRIVAC E vacuum pumps is supplied separately.

---

## IMPORTANT SAFETY CONSIDERATIONS

The Leybold TRIVAC E vacuum pump is designed for safe and efficient operation when used properly and in accordance with this manual. It is the responsibility of the user to carefully read and strictly observe all safety precautions described in this section and throughout the manual. This product must be operated and maintained by trained personnel only. Consult local, state, and national agencies regarding specific requirements and regulations. Address any further safety, operation and/or maintenance questions to your nearest Leybold Vacuum office.

### Warning Failure to observe the following precautions could result in serious personal injury:



- Before beginning with any maintenance or service work on the TRIVAC E, disconnect the pump from all power supplies.
- Do not operate the pump with any of the covers removed. Serious injury may result.



- If exhaust gases must be collected or contained, do not allow the exhaust line to become pressurised.
- Make sure that the gas flow from the exhaust port is not blocked or restricted in any way.



- The standard version of the TRIVAC E is not suited for operation in explosion hazard areas. Contact us before planning to use the pump under such circumstances.
- Before starting up for the first time, the motor circuit (3 phase) must be equipped with a suitable protective motor switch. Please take note of the information in these Operating Instructions or on the electric motor (wiring diagram).

- The TRIVAC E is not suited for pumping of:
  - combustible and explosive gases or vapours
  - radioactive and toxic substances
  - pyrophorous substances.
  - oxidations substances.

- Avoid exposing any part of the human body to the vacuum.
- Never operate the TRIVAC E without a connected intake line or blank flange.
- The location at which the TRIVAC E (including its accessories) is operated should be such that angles over 10° from the vertical are avoided.
- The location of the TRIVAC E should be such that all controls are easily accessible.



- Under certain ambient conditions the TRIVAC E may attain a temperature of over 80 °C (176 °F). There then exists the danger of receiving burns. Note the symbols on the pump pointing to the hazards, and in the case of a hot pump wear the required protective clothing.
- Before pumping oxygen (or other highly reactive gases) at concentrations exceeding the concentration in the atmosphere (> 21 % for oxygen) it will be necessary to use a special pump. Such a pump will have to be modified and de-greased, and an inert special lubricant (like PFPE) must be used.

---

**Warning**

- Before operating the TRIVAC E with atmospheric gas ballast (optional) check first compatibility with the pumped media so as to avoid hazardous conditions during operation right from the start.
- Before commissioning the TRIVAC E, make sure that the media which are to be pumped are compatible with each other so as to avoid hazardous situations. All relevant safety standards and regulations must be observed.
- It is recommended to always operate the TRIVAC E with a suitable exhaust line which is properly connected. It must slope down and away from the pump.
- When moving the TRIVAC E always use the allowed means. A lifting eye is provided as standard on the pump.

**Caution Failure to observe the following precautions could result in damage to the pump:**

- Do **not** allow the ingestion of small objects (screws, nuts, washers, pieces of wire, etc.) through the inlet port. Always use the screen which is supplied with every pump.
- Do **not** use the pump for applications that produce abrasive or adhesive powders or condensable vapours that can leave adhesive or high viscosity deposits. Please contact Leybold Sales or Service to select a suitable separator. Also please contact Leybold Sales or Service when planning to pump vapours other than water vapour.
- This pump is suited for pumping water vapour within the specified water vapour tolerance limits.
- Avoid vapours that can condense into liquids upon compression inside the pump, if these substances exceed the vapour tolerance of the pump.
- Before pumping vapours, the TRIVAC E should have attained its operating temperature, and the gas ballast should be set to position I - III (position 0 = closed, position 3 = max. water vapour tolerance, 30 mbar).  
The pump will have attained its operating temperature about 30 minutes after starting the pump. During this time the pump should be separated from the process, by a valve in the intake line, for example.
- In the case of wet processes we recommend the installation of liquid separators upstream and downstream of the pump as well as the use of the gas ballast.
- The exhaust line should be laid so that it slopes down and away from the pump so as to prevent condensate from backstreaming into the pump.
- The entry of particles and fluids must be avoided under all circumstances.
- Reactive or aggressive substances in the pump chamber may impair the operating oil or modify it. In addition, such substances may be incompatible with the materials of the pump (Viton, grey cast iron, aluminium, steel, resins, glass etc.).
- Corrosion, deposits and cracking of oil within the pump are not allowed.

**Note****This information will help the operator to obtain the best performance from the equipment:**

- Normal amounts of humidity within the range of the pump's vapour tolerance will not significantly affect pump performance when the gas ballast is active. Preferably use the exhaust flange located on the side of the motor.

**Key to Fig. 1**

- 1 Intake port
- 2 Oil drain
- 3 Oil level indicator
- 4 Name plate
- 5 Oil fill
- 6 Exhaust port
- 7 Gas ballast valve
- 8 Mains power connection

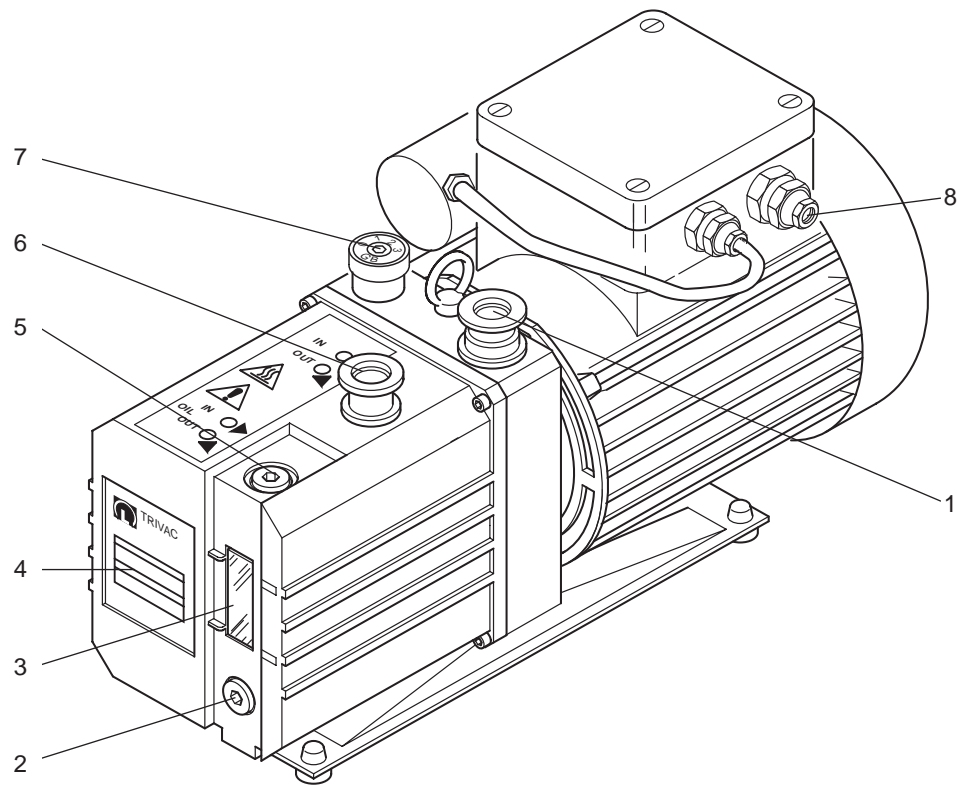

Fig. 1 TRIVAC D 5 E rotary vane pump (other TRIVAC E models are similar)

# 1 Description

The TRIVAC D 5 - 16 E are dual stage oil sealed rotary vane vacuum pumps.

The number in the designation of the pump indicates the pumping speed of this pump in  $\text{m}^3 \cdot \text{h}^{-1}$ .

These pumps are capable of pumping gases and vapours out of vessels and vacuum systems down into the fine vacuum pressure range. The standard pumps are not designed to handle oxygen at concentrations exceeding the concentration of oxygen in the atmosphere. Moreover, these pumps are not suited for pumping of hazardous gases or extremely aggressive or corrosive media.

The drive motor of the TRIVAC D 5 to 16 E is screwed directly to the bearing piece. The shaft of the pump and the shaft of the motor are linked by a coupling piece. The bearings in the inner pump body are force-lubricated sliding bearings.

The oil level glass for viewing the minimum/maximum oil level and the oil drain plug as well as the name plate are located on the front of the pump.

The connection components, the gas ballast knob and the oil fill plug are located on the top of the pump.

## 1.1 Principle of Operation

The rotor (2/6) which is eccentrically arranged in the pump housing (pump chamber) has two radially sliding vanes (2/7 and 2/9) which divide the pump chamber of the pump into several chambers.

The volume of each chamber changes periodically with each turn of the rotor so that the gas at the intake port (1/1) is sucked in. The gas enters the pump chamber, and after the admission aperture has been sealed off by the vane, the gas is compressed and moved on.

The compressed gas is ejected from the pump chamber through the exhaust valve. Oil which is entrained in the gas is roughly separated by an internal demister and at the same time any mechanical contaminations are also removed from the oil. The gas exits the pump through the exhaust port.

Oil injected into the pump chamber serves the purpose of sealing and lubrication. The knocking noise (oil slap) which normally occurs when the pump approaches its ultimate pressure is avoided by injecting a small amount of air into the oil so that a silencing effect is attained.

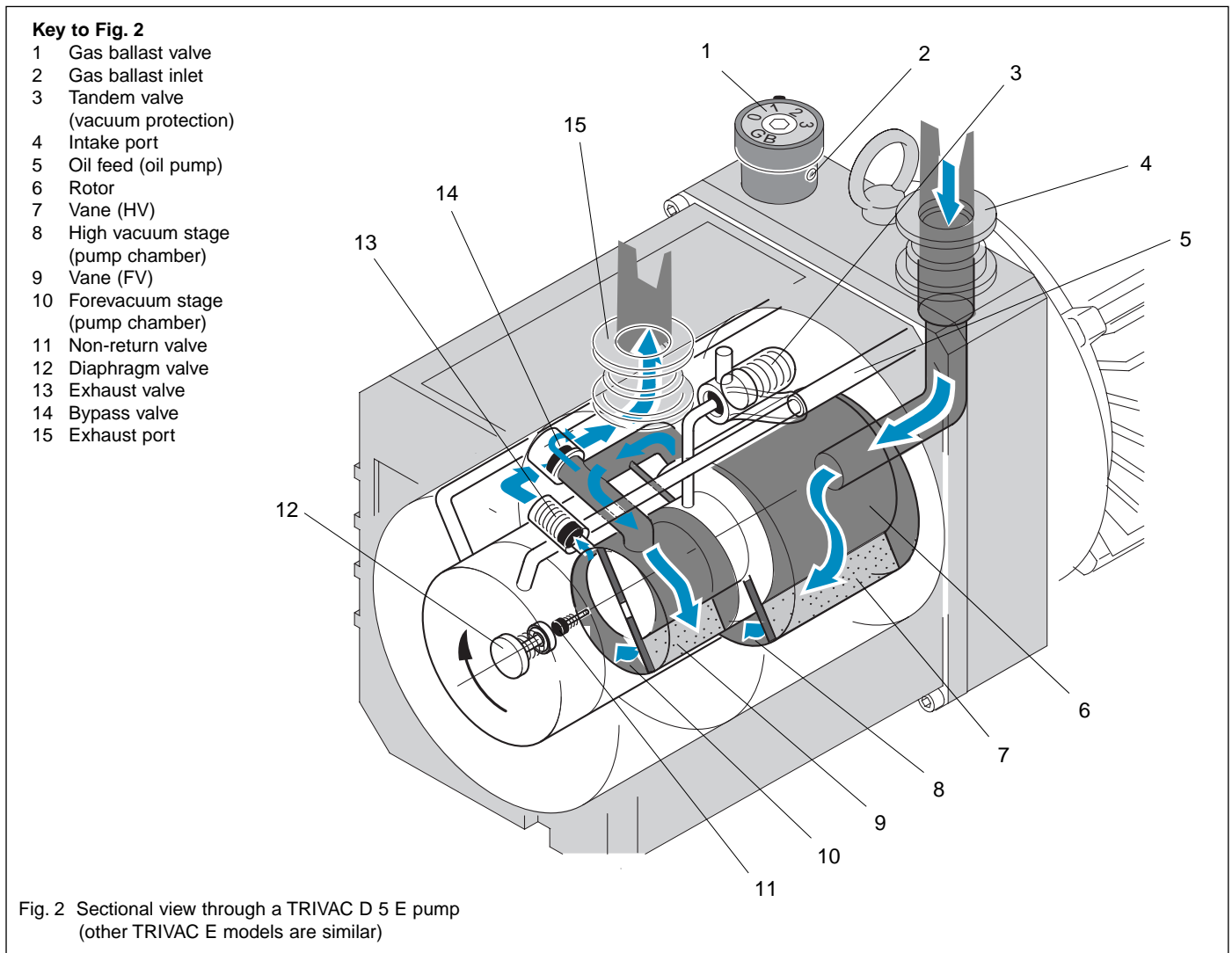

By opening the gas ballast valve (2/1, optional) it is possible to admit a controlled quantity of air (gas ballast) into the pump chamber while the compression process is in progress. The gas ballast will prevent the condensation of vapours within the pump up to the extent of the vapour tolerance levels as stated in the specifications for the pump (these data refer to water vapour).

A special lubrication system with forced lubrication of the sliding bearings has been developed to enable operation of the pump at intake pressures up to 1000 mbar.

An oil pump supplies the oil from the oil reservoir into a high pressure oil system which in turn supplies all bearings. From here the oil enters the pump chamber of the vacuum pump.

The oil pump is located in bearing piece of the high vacuum stage. Separation of oil and gas in the pump involves two stages. First an internal demister which is arranged ahead of the exhaust valve ensures the creation of larger droplets.

Next these are returned back to the oil reservoir via a separation panel. This ensures a minimal loss of oil.

This and the combination with the large usable oil reservoir, results in long intervals between the oil exchanges, even at high intake pressures.

The gas ballast valve (**GB**) is opened or closed by turning it (positions 0, 1, 2, 3).

Available as an option is a gas ballast valve having a knurled screw (see Fig. 13 on page 28). When fully opening this valve, the resulting gas flow will correspond to that of valve position 3 in the following Table.

GB position	Explanation
0	no gas ballast maximum ultimate pressure
1	for cleaning the pump's oil at a good ultimate pressure and low oil consumption
2	good water vapour tolerance - without producing excessive noise
3	maximum water vapour tolerance in accordance with the technical data on page 6.

When the pump is at standstill (mains power failure, or when the pump is shut down) the pump chamber is hermetically sealed off by two safety valves (tandem valve and gas ballast diaphragm valve) which are controlled through the oil pressure.

This reliably avoids any inadvertent venting of the vacuum chamber and the backstreaming of oil.

## 1.2 Supplied Equipment

Each TRIVAC D 5 - D 16 E pump is supplied with the following basic equipment:

- Pump with motor
- Separately included oil filling (see Section 1.2.1)
- Separately included dirt sieve with O-ring
- Operating Instructions
- "Declaration of Contamination" form

The connection ports are provided with foil protectors for protection during shipping.

The TRIVAC E pumps having an AC motor are supplied ready for operation, complete with switch, built-in thermal motor overload protection, mains cord (1.8 m long) and a mains plug which depends on the country of use.

The three-phase models do not come with the accessories needed for the electrical connection. However, these accessories are available upon request.

### 1.2.1 Notes on the Oil and how to Order

Oil N 62 or HE 200 is used as standard. If any other kind of special oil is being used, this fact will be indicated by a sticker on the oil box stating the type of special oil used.

Not all types of oil have been released for all pumps. You must only use the kind of oil which has been specified for the particular pump.

## 1.3 Accessories

### Cat. No. /Order No.

Exhaust filter AF 10, DN 25 KF . . . . .	190 51
Exhaust filter AF 16, DN 25 KF . . . . .	190 52
Replacement filters FE 10 (set of 5) . . . . .	190 81
Replacement filters FE 16 (set of 5) . . . . .	190 82
Drain clock for the exhaust filter AF 8/10/16 . . . . .	190 95
Condensate separator AK 10, DN 25 KF . . . . .	190 61
Condensate separator AK 16, DN 25 KF . . . . .	190 62
Oil drain cock (for D 5 E - D 16 E) . . . . .	190 90
Manual oil return via the gas ballast port . . . . .	190 93
(Kit for AF 8-16) ARM	

Connection components required to connect the exhaust filter and the condensate separators in each case:

1 Pipe bend	DN 25 KF	184 37
2 Centering rings with O-ring	DN 25 KF	183 27
2 Clamping rings	DN 25 KF	183 42

## 1.4 Technical Data

		D 5 E	D 10 E	D 16 E
Nominal pumping speed* 50/60 Hz	m <sup>3</sup> ·h <sup>-1</sup>	6/7,3	12/14,6	21/23,6
Pumping speed 50/60 Hz	m <sup>3</sup> ·h <sup>-1</sup>	5,2/6	9,9/11,3	16/19
Ult. partial pressure without gas ballast	mbar	≤ 5 x 10 <sup>-4</sup>	≤ 5 x 10 <sup>-4</sup>	≤ 5 x 10 <sup>-4</sup>
Ult. total pressure without gas ballast**	mbar	≤ 2 x 10 <sup>-3</sup>	≤ 2 x 10 <sup>-3</sup>	≤ 2 x 10 <sup>-3</sup>
Ult. total press. w. gas ballast (stage 2)**	mbar	≤ 3 x 10 <sup>-2</sup>	≤ 3 x 10 <sup>-2</sup>	≤ 3 x 10 <sup>-2</sup>
Water vapour tolerance				
Stage 1	mbar	10	10	10
Stage 2	mbar	30	20	20
Stage 3	mbar	40	30	30
Connection port	DN	16 KF	25 KF	25 KF
Noise level (50 Hz)	dB (A)	≤ 49	≤ 49	≤ 52
Permissible ambient temperature	°C	10 bis 50 (EURO - Motor) / 10 to 40 (USA/Japan - Motor)		
Oil filling max./min	l	1,25/0,75	1,25/0,75	1,25/0,75
Motor power 50/60 Hz	W	450/550	450/550	700/850
Speed 50/60 Hz	rpm	1350/1650	1350/1650	1380/1650
Protection	IP	54	54	54
Weight with operating agent***kg	kg	22,1	24,2	30,7
Dimensions (W x H x D)***	mm	156 x 258 x 416	156 x 258 x 435	170 x 258 x 494

\* to DIN 28 426 T1 \*\* to DIN 28 400 and subsequent numbers \*\*\* Dimensions and weights with Euro motor

### 1.4.1 Motor Dependent Data

Motors for	Voltage	Frequency	Voltage	Power consumption	Nom. current	Fuse*	Protection	Nom. speed
D 5 E	(V)	(Hz)	tolerance	(W)	(A)	(A)	IP	(rpm)
Euro 1~	220-240/230	50/60	± 5 %	450/540	2,5/2,4	10	54	1350/1650
Three-ph. motor	Δ 220-240/	50	± 5 %	550	2,8	6	54	1500
3~	Y 346/415				1,6			
	Δ 200-266/	60	± 5 %	650	2,8	6	54	1800
	Y 346-460				1,6			
Motors for	Voltage	Frequency	Voltage	Power consumption	Nom. current	Fuse*	Protection	Nom. speed
D 10 E	(V)	(Hz)	tolerance	(W)	(A)	(A)	IP	(rpm)
Euro 1~	220-240/230	50/60	± 5 %	450/540	2,5/2,4	10	54	1350/1650
Three-ph. motor	Δ 220-240/	50	± 5 %	550	2,8	6	54	1500
3~	Y 346/415				1,6			
	Δ 200-266/	60	± 5 %	650	2,8	6	54	1800
	Y 346-460				1,6			
Wide voltage- motor 1~	110-120; 208-240	50/60	± 5 %	490/550	6,8/5,6 3,4/2,8	10	54	1350/1650
Motors for	Voltage	Frequency	Voltage	Power consumption	Nom. current	Fuse*	Protection	Nom. speed
D 16 E	(V)	(Hz)	tolerance	(W)	(A)	(A)	IP	(rpm)
Euro 1~	220-240	50/60	± 5 %	700/850	5,3/4,6	10	54	1380/1650
Three-ph. motor	Δ 220-240/	50	± 5 %	650	4	10	54	1430
3~	Y 346-415				2,3			
	Δ 200-277/	60	± 5 %	750	3,6	10	54	1720
	Y 346-480				2,1			

\*The values stated for the fuses are recommended values only

Values for up-front fuses for short circuit protection. Please take note of the information provided by the manufacturers of contactors and motor protection switches.

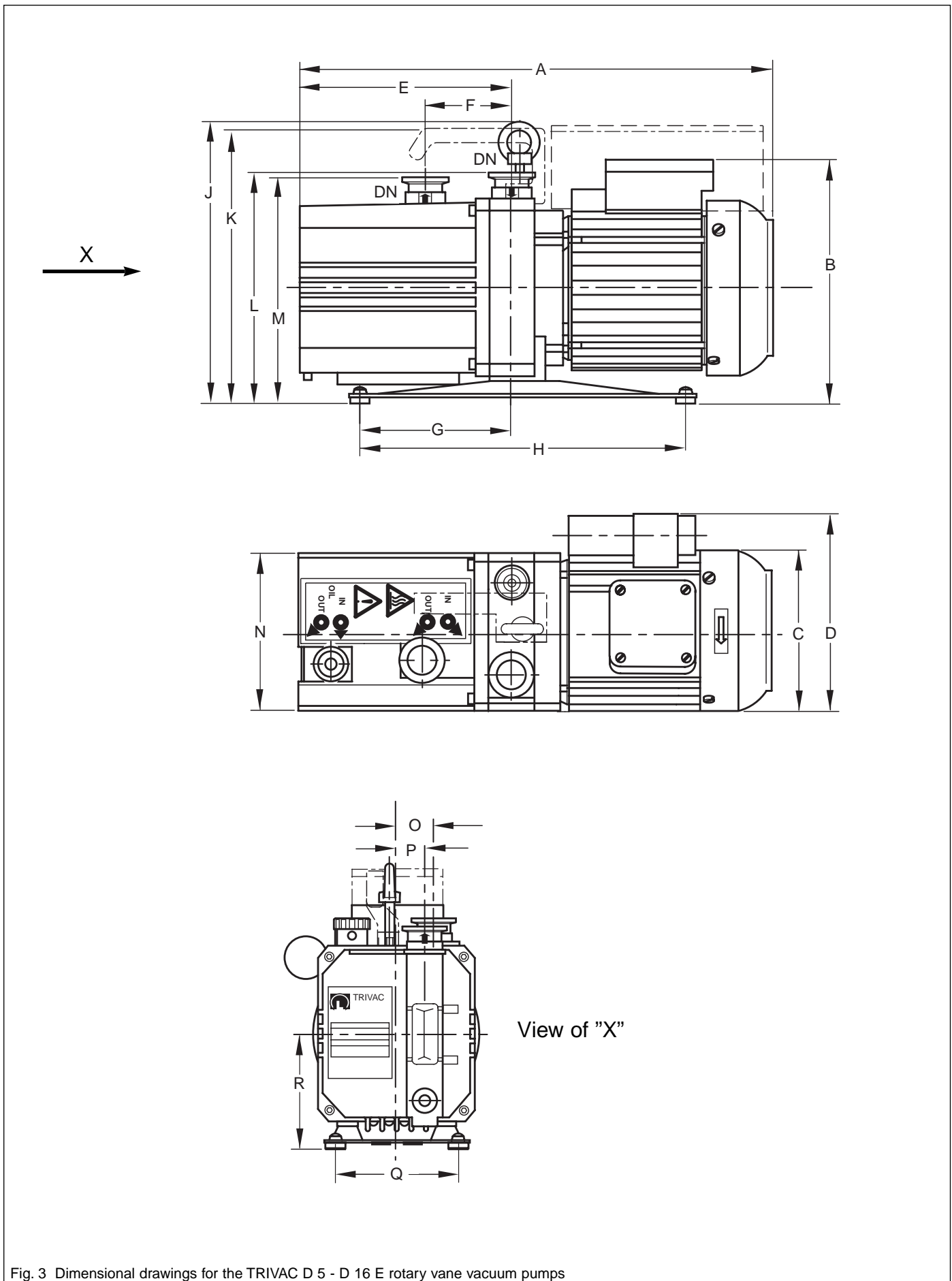

Fig. 3 Dimensional drawings for the TRIVAC D 5 - D 16 E rotary vane vacuum pumps

Table of dimensions for Fig. 3

Description	D 5 E	D 10 E	D 16 E
A	1~, EURO	421	440
	1~, World	-	440
	3~, World	421	440
B	1~, EURO	231	231
	1~, World	-	249
	3~, World	212	212
C	1~, EURO	156	156
	1~, World	-	156
	3~, World	156	156
D	1~, EURO	182	183
	1~, World	-	**
E	192	195	231
F	77	80	116
G	143	140	176
H	300	300	300
J	258	258	258
K	253	253	253
L	210	210	210
M	205	205	205
N	140	140	140
O	38	38	38
P	29	29	29
Q	110	110	110
R	105	105	105
DN	16	25	25

\* Capacitor at both sides of the motor

all dimensions in mm

\*\* Capacitor in the terminal box

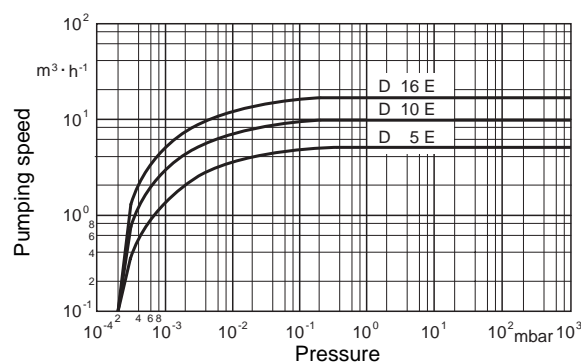

Fig. 4 Pumping speed characteristics of the TRIVAC D 5 E - D 16 E

## 2 Operation

### 2.1 Installation

The TRIVAC D 5 E - D 16 E can be placed freely on a flat and horizontal surface.

The rubber elements under the pump's base prevent the pump from slipping. If the pump is to be permanently attached, this may be done by making use of the holes in the rubber elements and a threaded bolt or similar.

**Caution** The inclination of the pump (without additional fixing means) and with possibly attached standard accessories must not exceed an angle of 10 ° from the vertical axis.

The rubber elements act as vibration absorbers. For this reason they must not be compressed by the screws. When installing the pump you must ensure accessibility of all connections and controls.

Select a place for the pump which ensures a sufficient air circulation for cooling the pump (keep front and rear sides unobstructed).

The ambient temperature around the pump should not exceed 50 °C (in the case of USA and Japan motors 40 °C) and not drop below 10 °C (see Section 2.5.3).

If required the crane eye or the handle may be removed.

**Caution** The oil filling has been included separately. Before operating the pump you must fill in the correct quantity of oil (see Section 3.2).

### 2.2 Connection to the System

Before connecting the pump, the shipping seals on the connection flanges (6/1 and 6/2) must be removed.

If residues of adhesives are present on the connecting flanges you must remove these using a suitable solvent like alcohol, for example.

Insert the dirt sieve (6/8) with the O-ring.

The intake and exhaust lines are fitted with standard small flanges. The connection flanges must be clean and undamaged.

The intake line and the exhaust line must be connected using corrugated pipes or vacuum hoses so that no mechanical forces can be transferred to the pump.

The intake line must be clean. Any deposits in the intake line will tend to degas and impair the attainable vacuum pressures.

The cross section of the intake and exhaust line must at least be of the same diameter as that of the pump connections.

An intake line which is too small in diameter will throttle the pumping speed.

An exhaust line which is too small in diameter can result in the formation of overpressures within the pump. Possible consequences are damaged shaft seals and possibly also an oil leak.

The pressure in the oil box must not exceed 1.5 bar (abs.)

When pumping vapours we strongly recommend the installation of a condensate separator on the suction side and also on the exhaust side.

The exhaust line must be laid so that it slopes down and away from pump (lower than the pump) to prevent any condensate from flowing back into the pump. If a sloping line can not be installed, a separator must be fitted.

When the oil mist is to be removed from the exhaust gas flow we recommend the installation of an exhaust filter.

When pumping inert gases the pump's gas ballast inlet can directly be connected to the system by an adaptor (for this the gas ballast knob must be removed).

Intake and exhaust port are of the screwed type and can be replaced by direct connection to the system.

## 2.3 Electrical Connection

**Warning** During all electrical work ensure that the power supply lines have reliably been switched off and protected against being switched on inadvertently.



In order to prevent the pump from running up unexpectedly after a power failure, the pump must be connected to the system controller in such a way that the pump may only be re-started manually. This applies equally after the pump has been switched off through an emergency switch.

The electrical connections may only be made by an electrician as defined by VDE 0105 in accordance with the VDE 0100 guidelines.

The pumps are supplied with either an AC motor or a three-phase motor.

### 2.3.1 Pumps with AC Motor

The pump may be directly connected via its mains cable and its plug to the mains.

In the case of 230 V mains, 6 A slow blow or 10 A fast blow fusing is required as a minimum.

A check on the direction of rotation is not required since this is fixed.

The thermal motor overload protector protects the motor in case it is overloaded.

The mains voltage must comply with the voltage stated on the name plate.

**Warning** When the thermal motor overload protection system has switched the motor off, the motor will automatically cut in again when the temperature has dropped below the maximum permissible operating temperature.



### 2.3.2 Pumps with Three-Phase Motor

The TRIVAC E pumps equipped with a three-phase motor are delivered without the components required for their electrical connection.

You must connect the pump using an appropriately rated cable (we recommend: AWG 18 for the 5 to 10 type models and AWG 16 for the 16 type modes) and a suitably rated motor protection switch. The value set on the motor protection switch must correspond to the current rating stated on the name plate of the motor.

Shown in Fig. 5 is the way in which the pump having a three-phase motor (50/60 Hz) may be connected in Star or Delta fashion. Please also take note of the information given on the name plate of the motor.

**Caution** After having connected the motor and each time after having made a change to the wiring you must check the direction of rotation.

For this switch the motor on briefly and determine whether or not a suitable plate (a blank flange, for example) held in front of the intake is sucked towards the pump's body. If this is not the case you must interchange two of the mains phases.

Note the direction indicating arrow on the fan cowl.

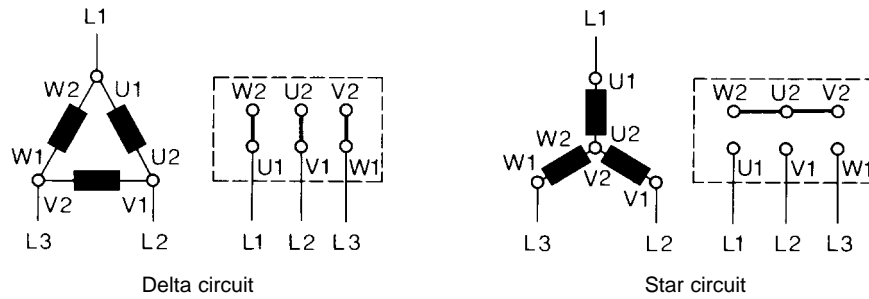
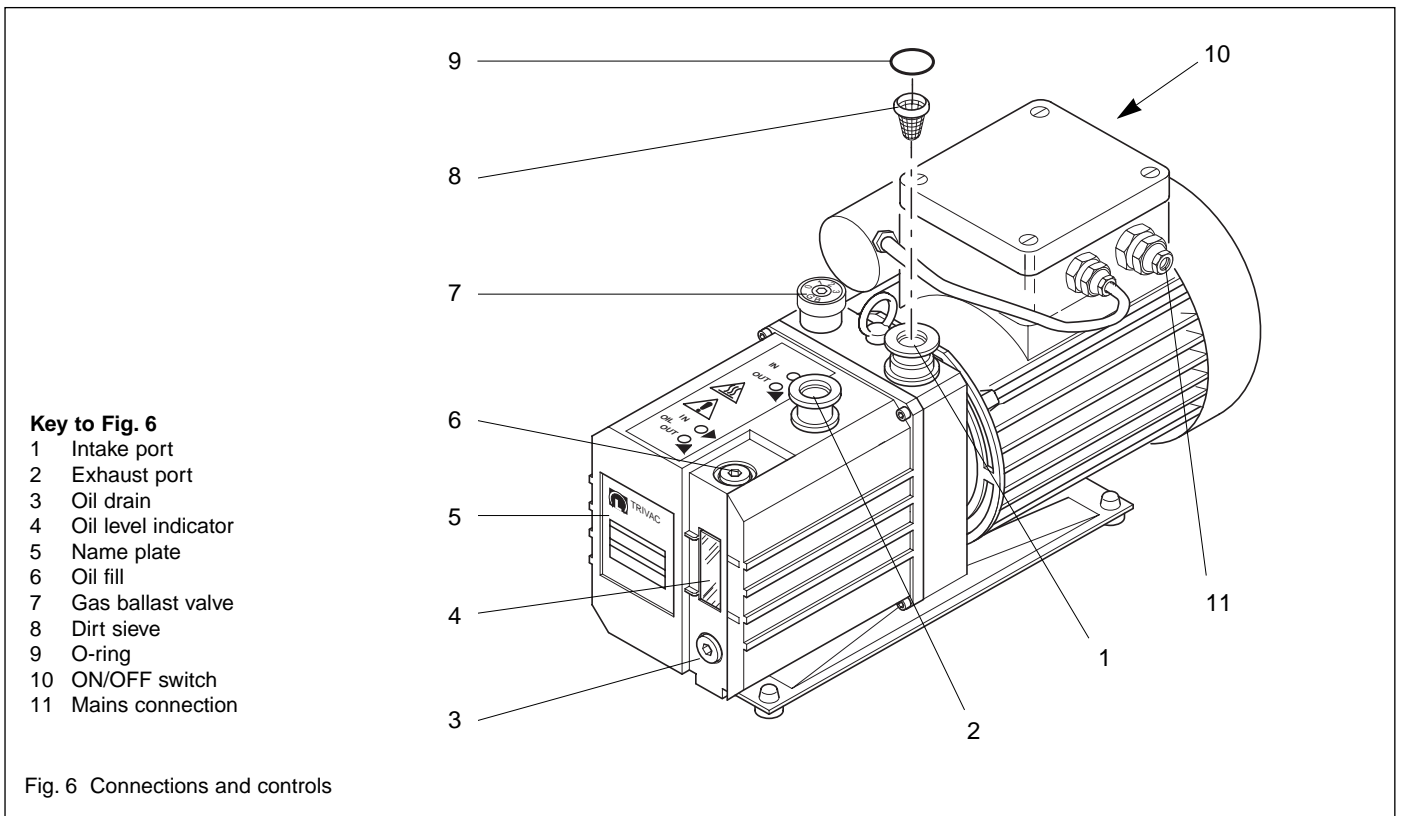

Fig. 5 Wiring diagram for the TRIVAC E pumps with three-phase motor

**2.3.2.1 Current Drawn by the Three-Phase Motors of the TRIVAC D 5 E - D 16 E**

	Voltage ranges for the three-phase motors	Max. current consumption at an intake pressure of about 300 mbar	Min. current consumption at ultimate pressure	Setting for the motor protection switch (motor data)	
<b>TRIVAC D 5 / 10 E</b>					
Δ	50 Hz	200 V - 240 V	2.2 A - 2.6 A	1.6 A - 2.5 A	2.8 A
	60 Hz	200 V - 266 V	2.5 A - 2.3 A	1.4 A - 1.9 A	2.8 A
Y	50 Hz	346 V - 415 V	1.2 A - 1.5 A	0.9 A - 1.4 A	1.6 A
	60 Hz	346 V - 460 V	1.4 A - 1.35 A	0.8 A - 1.2 A	1.6 A
<b>TRIVAC D 16 E</b>					
Δ	50 Hz	200 V - 240 V	3 A - 3.8 A	2 A - 3.3 A	4 A
	60 Hz	200 V - 277 V	3.3 A - 3.5 A	1.8 A - 3.1 A	3.6 A
Y	50 Hz	346 V - 415 V	1.8 A - 2.1 A	1 A - 1.5 A	2.3 A
	60 Hz	346 V - 480 V	1.95 A - 2 A	0.95 A - 1.45 A	2.1 A



## 2.4 Start Up

**Caution** Check the oil level each time before switching on the pump (see Section 3.2). After having connected the motor and each time after having made a change to the wiring you must check the direction of rotation (see Section 2.3.2).

The pump is started up by operating the ON/OFF switch (6/10 - does not apply in the case of pumps with a three-phase motor). The ON/OFF switch may be operated at all pressures.

During initial start up and after a longer period during which the pump has not been used, the pump may not immediately attain the specified ultimate pressure because the oil has to be degassed first.

For this you should let the pump run for about 30 minutes with the intake line closed and the gas ballast valve (6/7) open (position 2 of the gas ballast valve).

## 2.5 Operation

These pumps are capable of pumping gases and vapours. Vapours can only be pumped provided the gas ballast valve (optional) is open and provided the pump has attained its operating temperature.

The maximum vapour tolerance is attained when the gas ballast valve (6/7) is set to position 3.

### 2.5.1 Pumping of Non-Condensable Gases and Vapours

In the presence of excess quantities of permanent gases the pump may be operated without gas ballast, provided the saturation vapour pressure at the operating temperature is not exceeded during compression.

If the composition of the gases which are to be pumped is not known and if the possibility of condensation within the pump can not be excluded, we recommend operation of the pump with the gas ballast valve open (in accordance with Section 2.5.2).

## 2.5.2 Pumping of Condensable Gases and Vapours

With the gas ballast valve (option) open and when the pump is running at its operating temperature, pure water vapour can be pumped up to the extent stated in the technical data for the pump (position 3 of the gas ballast valve). When the vapour pressure increases above the permissible level, the vapour will condense in the oil of the pump.

When pumping vapours make sure that the gas ballast valve is open and that the pump has been running for at least 30 minutes with the intake line closed and with gas ballast.

**Caution** It will be possible to pump vapours up to the permissible limit only after the pump has reached its operating temperature. During the pumping process vapours may dissolve in the oil of the pump. This impairs the properties of the oil and there is the risk of corrosion within the pump. For this reason the pump must not be switched off immediately after termination of the process. The pump must remain on with the gas ballast valve open and the intake line sealed until all vapours which were dissolved in the oil have been removed. We strongly recommend that the TRIVAC D 5 E - D 16 E pumps be left running for about 30 minutes after termination of the process.

In the case of cyclic or repetitive processes the TRIVAC D 5 E - D 16 E should not be switched off during the breaks between the individual work phases (low energy requirement when running at ultimate pressure). The gas ballast valve should be opened and the intake line should be sealed (through a valve, if possible).

When all vapours have been pumped from a process (drying, for example) the gas ballast valve can be closed to improve the attainable ultimate pressure.

## 2.5.3 Operating Temperature

Proper operation of the TRIVAC D 5 E - D 16 E is ensured at ambient temperatures between 10 °C and 50 °C, with the exception of the pump models for the USA and Japan where a range of 10 °C to 40 °C applies.

When using SHC 224 Arctic oil, the pump will reliably run up even at a temperature of 5 °C.

When the pump is warm, the temperature at the surface of the oil box may rise to between 40 °C and 80 °C, depending on the load on the pump.

**Warning** TRIVAC E pumps may attain surface temperatures of over 80 °C.



There is the danger of receiving burns.



## 2.6 Shut Down / Shelving

During normal use of the TRIVAC D 5 E - D 16 E it will be sufficient to electrically switch off the pump. Further measures are not required.

After having pumped condensable media, let the pump run for some time with the gas ballast valve open and the intake line blocked (see Section 2.5.2).

When pumping aggressive or corrosive media and also in the case of long process interruptions (overnight, for example) we recommend that you let the pump run with the intake line sealed and with the gas ballast switched on.

This helps to prevent the occurrence of standstill corrosion.

If the pump is to be switched off for a longer period of time after it has been pumping aggressive or corrosive media or if the pump is to be shelved, proceed as follows:

**Warning** When hazardous substances have been pumped ensure that the appropriate safety precautions are observed.



For more information please contact our technical sales department.

Seal off the intake port. The use of special conservation or anti-corrosion oils is not required.

### 2.6.1 Shut Down through Monitoring Components

**Warning** When the pump has been switched off due to overheating sensed by the motor coil protector (single phase pumps only), the pump must only be started manually after the pump has cooled down to the ambient temperature and after having removed the cause first.



### 2.6.2 Failure of the Control System or the Mains Power

**Warning** In order to prevent the pump from running up unexpectedly after a mains power failure, the pump must be integrated in the control system in such a way that the pump can only be switched on again manually. This applies equally to emergency cut-out arrangements.



## 3 Checking / Maintenance

**Warning** Before starting any disassembly work, disconnect all electrical connections to the pump. Reliably prevent the pump from running up.



When the pump has been pumping hazardous substances, determine the nature of the hazard and make sure that the appropriate safety measures are observed.



Observe all safety regulations!

**Caution** When disposing of the waste oil, observe the applicable regulations for the safety of the environment.

Due to the concept of the TRIVAC E these pumps will hardly require any maintenance under normal operating conditions. The necessary maintenance work is described in the following sections. In addition a maintenance plan is provided in Section 4.

**Caution** All work should be left to trained personnel. Improperly performed maintenance or repair work endangers the durability and operational readiness and will lead to difficulties when wanting to file any warranty claims.

Also available from LEYBOLD are seminars covering practical aspects like maintenance, repair and checking of the TRIVAC E which are run under the supervision of our experts. For more information on these seminars please contact us at LEYBOLD.

**Caution** If the pump is used in strongly contaminated ambient air you must ensure that operation of the gas ballast system and the air cooling is not impaired. When the TRIVAC E has been pumping corrosive media, we strongly recommend that you conduct any possibly due maintenance immediately in order to avoid corrosion during standstill.

Spare Parts are contained in the Repair Sets and in the Maintenance Kits. If required, ask us for a quotation on spare parts.

In the case of custom models and variants please always state the custom, variant and serial number.

### 3.1 Checking the Oil Level

During operation the oil level of the TRIVAC E must always be visible between the marks on oil viewing glass (7/2 and 7/3). The quantity of oil must be checked and topped up as required.

**Recommendation:** The oil level should always be visible in the middle of the oil viewing glass.

**Caution** The pump must be switched off before topping up any oil.

#### 3.1.1 Oil Check

The ageing process of the standard operating agent N 62 / HE 200 (see Section 1.2.1) basically depends on the operating conditions of the pump. You may check the condition of the oil as follows:

- **Visually**

Normally the oil will be light and transparent. In the case of increasing discolouration of the oil (it becomes darker) we recommend that you exchange the oil.

- **Chemically**

The neutralisation value for N 62 is determined in accordance with DIN 51558. When the neutralisation value exceeds the value of 2 you must change the oil.

- **Mechanically**

When the viscosity of N 62 exceeds a value of 240 mPas at 25 °C (20 % over viscosity of fresh oil) we recommend that you change the oil.

When gases or liquids are dissolved in the oil, the attainable ultimate pressure will be impaired. In such cases the oil may possibly be degassed by letting the pump run for about 30 minutes with the intake line closed and the gas ballast valve open.

## 3.2 Oil Change

**Warning** Before pumping oxygen (or other highly reactive gases) at concentrations exceeding the concentration in the atmosphere (> 21 % for oxygen) it will be necessary to use a special pump. Such a pump will have to be modified and de-greased, and an inert special lubricant (like PFPE) must be used.



For proper operation of the pump, it is essential that the pump has an adequate supply of the correct and clean oil at all times.

The oil must be changed when it looks dirty or if it appears chemically or mechanically worn out (see Section 3.1.1).

The oil should be changed after the first 100 operating hours and then at least every 2,000 to 3,000 operating hours or after one year. At high intake pressures and intake temperatures and/or when pumping contaminated gases, the oil will have to be changed much more frequently.

Further oil changes should be made before and after long-term storage of the pump.

**Caution** Only change the oil after the pump has been switched off and while the pump is still warm.

Required tool: Allen key 8 mm.

Remove the oil drain plug (7/4) and let the used oil drain into a suitable container. When the flow of oil slows down, screw the oil drain plug back in, briefly switch on the pump (max. 10 s) and then switch it off again. Remove the oil drain plug once more and drain out the remaining oil.

Screw the oil drain plug back in (check the gasket and reinstall a new one if necessary).

Remove the oil fill plug (7/1) and fill in fresh oil.

Screw the oil fill plug (7/1) back in.

**Warning** If there is the danger that the operating agent may present a hazard in any way due to decomposition of the oil, or because of the media which have been pumped, you must determine the kind of hazard and ensure that all necessary safety precautions are taken.

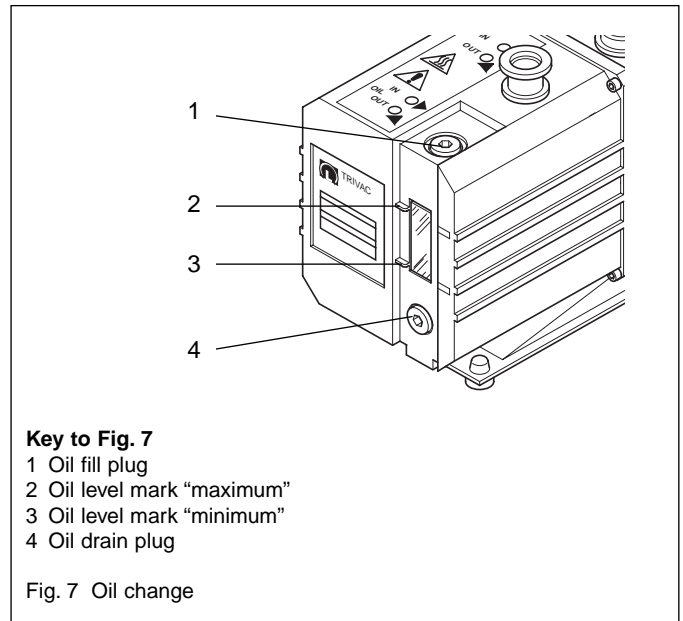

**Caution** We can only guarantee that the pump operates as specified by the technical data if the lubricants recommended by us are used.

### 3.2.1 Disposal of Used Pump Materials

The corresponding national environmental and safety regulations apply. This applies equally to used filters and filter elements (oil filter, exhaust filter and dust filter).

**Warning** - In the case of hazardous substances determine the kind of hazard first and observe the applicable safety regulations. If the potential hazard still persists, the pump must be decontaminated before starting with any maintenance work. For professional decontamination we recommend our Leybold service.



- Never exchange the oil or the filters while the pump is still hot. Let the pump cool down to uncritical temperatures first. You must wear suitable protective clothing.

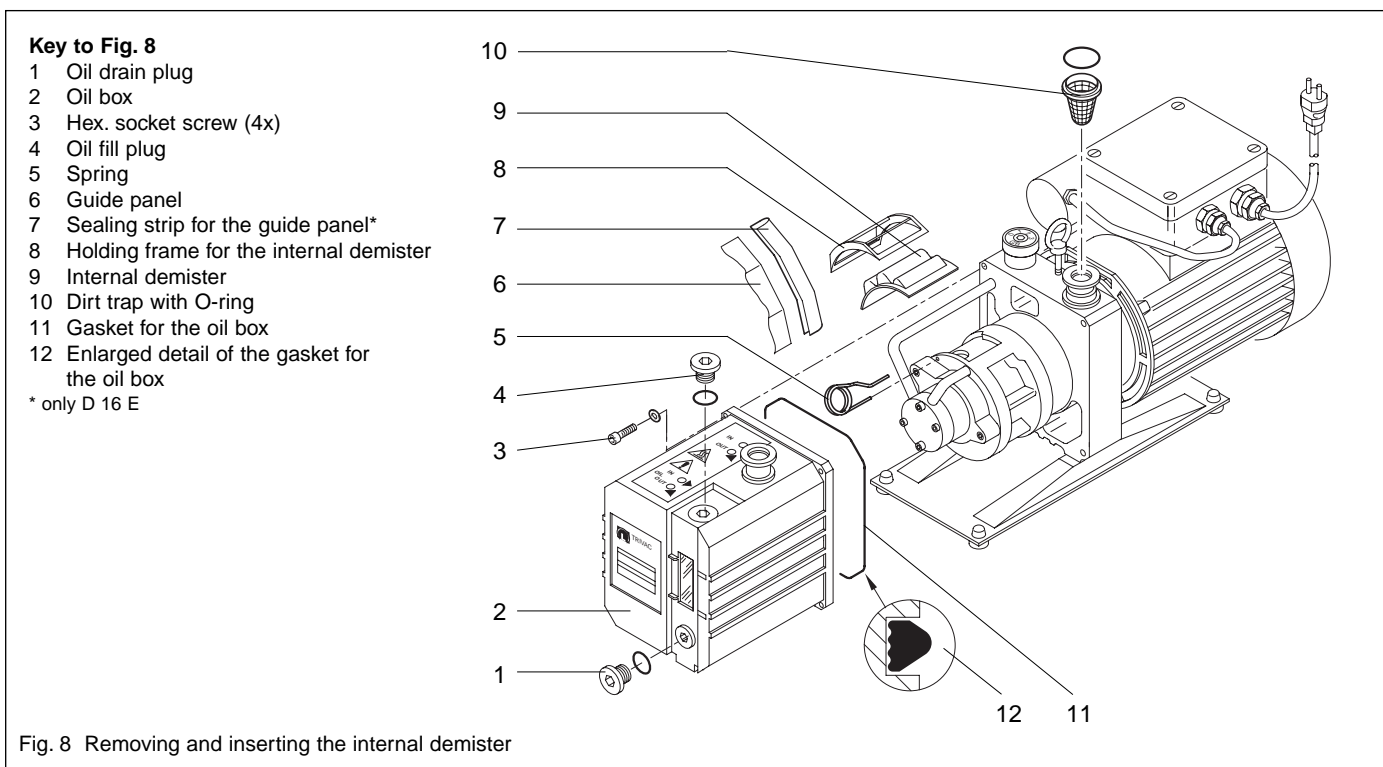

Fig. 8 Removing and inserting the internal demister

### 3.3 Cleaning the Dirt Trap

Located in the intake port is a wire mesh sieve acting as a dirt trap (8/10) for foreign objects. This sieve must be kept clean in order to avoid any throttling of the pump.

To clean the dirt trap remove it from the intake and clean it in a vessel using a solvent. Then thoroughly dry it with compressed air. If the dirt trap is faulty you must replace it.

**Caution** Adapt the cleaning intervals according to the requirements. If large quantities of abrasive materials are involved you should install a dust filter in the intake line.

### 3.4 Removing and Inserting the Internal Demister

#### *Simple maintenance on the side of the pump using Maintenance Kit 1*

Required tools:

Allan keys 4 and 8 mm

The internal demister has been installed in a resilient frame. When it has clogged it will lift itself up periodically at high intake pressures in order to equalise the resulting pressure difference.

The increased noise level at high intake pressure is thus a sign for a clogged internal demister.

Depending on the operating conditions the internal demister will have to be cleaned regularly or it must be exchanged. Cleaning must be performed using a suitable solvent.

Switch the pump off and drain out the oil (in accordance with Section 3.2).

In order to collect the remaining oil in the oil box we recommend that you lift the pump up slightly at the side of the motor.

Unscrew the four hex. socket screws (8/3) of the oil box.

Pull the oil box (8/2) out to the front.

Remove the gasket (8/11) of the oil box.

Use a pair of pliers to pull the spring (8/5) out to the front.

Detach the holding frame (8/8) and the internal demister (8/9).

Clean all parts and check them for perfect condition and replace them as required.

Reassemble in the reverse order.

**Caution** Make sure to fit the gasket for the oil box (8/11) with the flat side in the groove, see item 12 in Fig. 8.

Torque for the hex. socket screws (8/3) is 5.5 Nm.

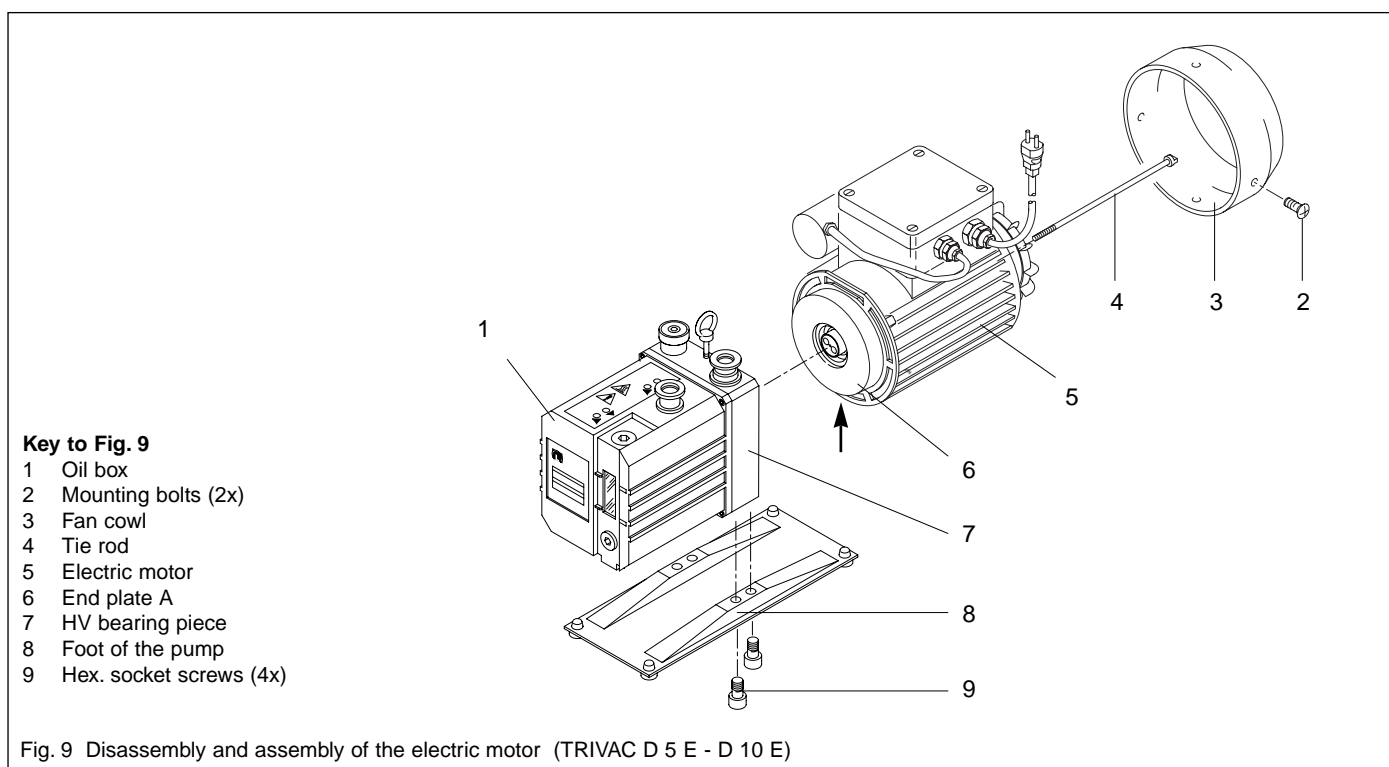

### 3.5 Disassembly and Assembly of the Electric Motor

**Warning** Before starting with any work on the pump, always reliably disconnect the motor from its power supply. Remove the mains connection (three-phase motors only) or pull the mains plug.



#### 3.5.1 Instructions for the TRIVAC D 5 E - D 10 E

Required tools:

Spanner size 8 and special tool for the tie rod.

We recommend that you remove the foot (9/9) of the pump.

Place the pump on the front side of the oil box (9/1). Remove the two (four) hex. screws (9/2) from the fan cowl (9/3).

Detach the fan cowl.

Unscrew the tie rod (9/4).

Detach the motor (lever off using two screwdrivers inserted in parallel between the end plate A and the HV bearing piece (9/6 and 9/7).

Clean all parts and make sure that they are in perfect condition; replace any parts as required.

In case of wear exchange the coupling bushings; these are included in Repair Set 1.

Reassemble in the reverse order.

Tighten the tie rods crosswise to 4 Nm.

Tighten the bolts for the pump's base to 23 Nm for the D 5 to 10 E.

**Caution** Especially note the position of the oil ejection hole (see arrow in Fig. 9) in the end plate A. The hole must always lead downward.

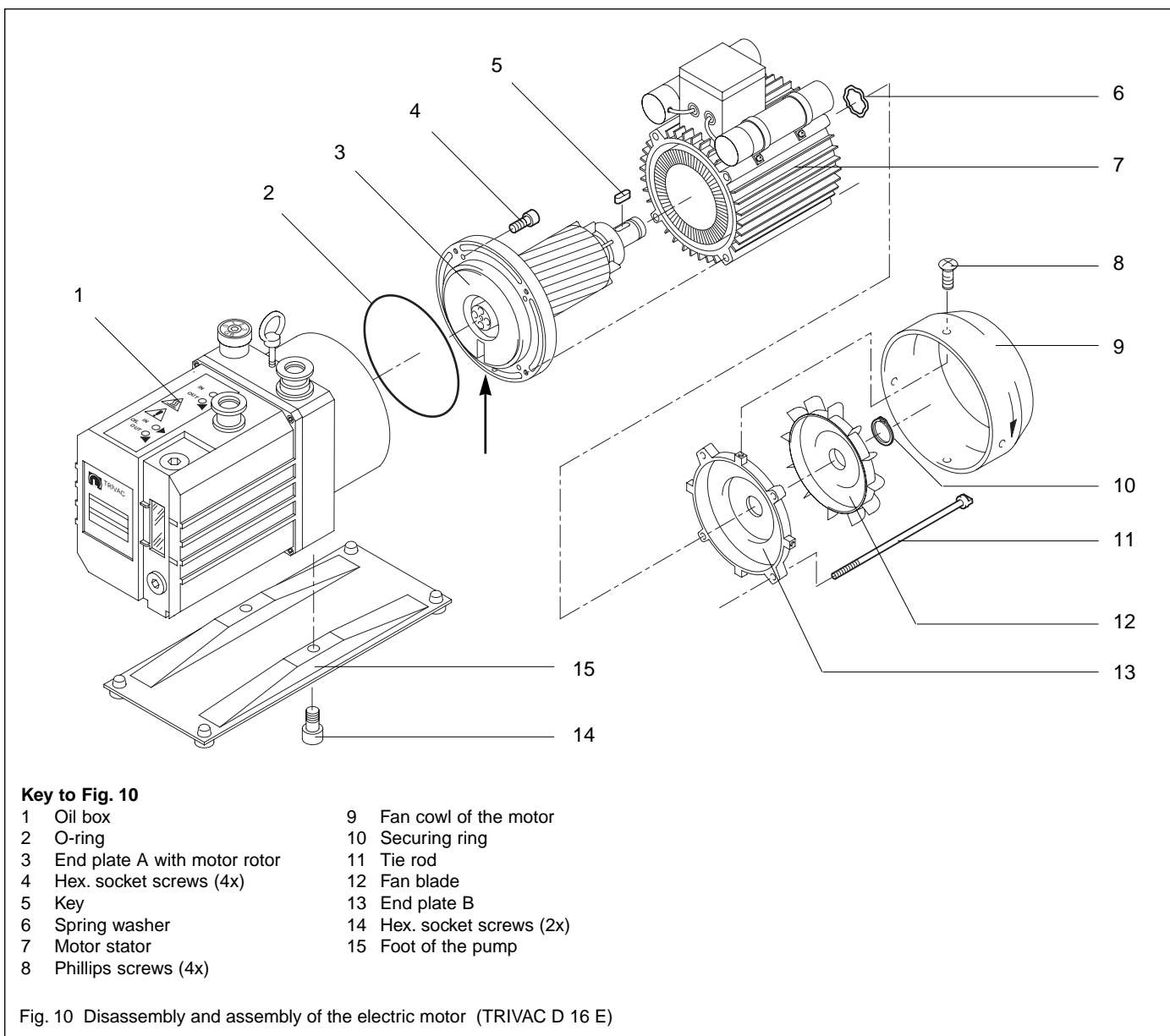

### 3.5.2 Instructions for the TRIVAC D 16 E

Required tools:

Phillips screwdriver, special tool for the tie rod, puller (two-point) for fan cowl, pliers for securing rings, combination pliers, size 4 Allan key.

We recommend to remove the foot (10/15) of the pump.

Place the pump on the front side of the oil box (10/1).

Remove the Phillips screws (10/8) from the fan cowl (10/9). Detach the fan cowl.

Disassemble the securing ring (10/10) of the fan blade (10/12).

Use the puller to detach the blade wheel.

Use a pair of pliers to disassemble the key (10/5).

Unscrew the tie rod (10/11), detach end plate B (10/13).

Lift off the stator (10/7) from the motor.

Unscrew the size 4 hex. socket screws (10/4) from end plate A (10/3).

Detach end plate A with the motor rotor and the spring washer (10/6).

Clean all parts and make sure that they are in perfect condition; replace any parts as required (Repair Set 1). Reassemble in the reverse order.

Tighten the tie rods crosswise to 5 Nm.

Also tighten the bolts at the A bearing plate to 5 Nm. The bolts at the pump's base are tightened to 23 Nm.

**Caution** Especially note the position of the oil ejection hole (see arrow in Fig. 10) in the end plate A. The hole must always lead downward.

### 3.6 Full Maintenance

Clean the pump and run maintenance on it.

Clean and perform maintenance on the pump as described in the instructions for Maintenance Kit 2.

### 3.7 Leybold Service

If a pump is returned to Leybold, indicate whether the pump free of substances damaging to health or whether it is contaminated.

If it is contaminated also indicate the nature of the hazard. For this you must use a form which has been prepared by us which we will provide upon request.

A copy of this form is reproduced at the end of these Operating Instructions: „Declaration of Contamination of Vacuum Instruments and Components“.

Please attach this form to the pump or enclose it with the pump.

This „Declaration of Contamination“ is required to meet the requirements of German Law and to protect our personnel.

**Caution** Leybold must return any pumps without a „Declaration of Contamination“ to the sender's address.

**Warning** The pump must be packed in such a way, that it will not be damaged during shipping and so that any contaminants are not released from the package.



### 3.8 Shelving

**Caution** Before putting a pump into operation once more it should be stored in a dry place preferably at room temperature (20 °C). Before the pump is shelved it must be properly disconnected from the vacuum system, purged with dry nitrogen and the oil should be changed too.

The inlets and outlets of the pump must be sealed with suitable seals.

The gas ballast valve must be set to the „0“ position and if the pump is to be shelved for a longer period of time it should be sealed in a PE bag containing some desiccant (silica gel).

When a pump is put into operation after it has been shelved for over one year, standard maintenance should be run on the pump and the oil should also be exchanged (see Section 3.2). We recommend that you contact the Leybold Service.

## 4 Maintenance Plan (Recommendation)

No.	Rotary vane pumps TRIVAC D 5 E - D 16 E	Measurem./ test quantity Operating / auxiliary agents	Interval					Remarks See also Op. Instructions,"Individual Components"
			VE	t	6m	a	n-a	
1	Operate the pump with gas ballast for at least 45 minutes.			x				Condensed water is thereby removed from the oil.
2	Check the oil level and change the oil as required.	Oil: N 62 or special and alternative types of oil, see Section 3.1	x	x				Topping up: only after the pump has been switched off.
3	Check the quality of the oil and change the oil as required.	visually  chemically  mechanically	x	x				<p><b>Visually:</b> Normal condition light and transparent, oil change is required at increasing discolouration.</p> <p><b>Chemically:</b> To DIN 51558, when the neutralization value exceeds 2, then an oil change is required.</p> <p><b>Mechanically:</b> When the dynamic viscosity at 25 °C &gt; 240 mPas, then an oil change will be required.</p> <p>Disposal of the used oil: see Section 3.2.1</p>
4	Clean the dirt trap in the intake and exchange it as required.	Suitable cleaning agent and compressed air.			x			<p><input type="checkbox"/> Clean the dirt trap with a cleaning agent and blow it clean with compressed air under a suction hood.</p> <p><input type="checkbox"/> Replace the faulty dirt trap. Use a cleaning agent which complies with national / international specifications.</p> <p><b>Observe the safety regulations which apply to the cleaning agent used.</b></p>
5	Clean the internal demister and change it as required.	Suitable cleaning agent.					x	<p>Perform cleaning also in advance of the scheduled maintenance interval when the noise increases more and more.</p> <p><input type="checkbox"/> Clean the internal demister with cleaning agent. <input type="checkbox"/> Replace a faulty internal demister. <input type="checkbox"/> Dispose of the used internal demister as special waste. Use a cleaning agent which complies with national / international specifications.</p> <p><b>Observe the safety regulations which apply to the cleaning agent used.</b> (parts are contained in Maintenance Kit 1) (see Section 5)</p>
6	Check the coupling bushings for damage and wear.						3	Check also in advance of the scheduled maintenance interval in case of extreme noise. (parts are contained in Repair Set 1, see Section 5)

No.	Rotary vane pumps TRIVAC D 5 E - D 16 E	Measur./ test quantity Operating / auxiliary agents	Interval					Remarks
			VE	t	6m	a	n-a	
7	Change the oil and  clean the oil level glass.	Oil: N 62 or special and alternative types of oil  Suitable cleaning agent and compressed air.				x		See also Op. Instructions,"Individual Components"  Oil change (see Section 3.2) • First oil change after 100 operating hours.  <input type="checkbox"/> Clean the oil level glass with a cleaning agent and blow it clean with compressed air under a suction hood. Use a cleaning agent which complies with national / international specifications.  <b>Observe the safety regulations which apply to the cleaning agent used.</b>  <b>Quantity of oil:</b> see Section 1.4. <b>Disposal of oil:</b> see page 2.
8	Check the pump's fan, the motor fan and the cooling fins of the motor for dirt, and clean as requi- red.	Brush and industrial vacuum cleaner.				x		When the pump or the motor is getting too warm clean before the stated maintenance interval. <b>Caution:</b> Switch the pump off and secure it against being started inadvertently (disconnect from the mains).
9	Full maintenance	Maintenance Kit 2.					3	Clean and perform maintenance on the pump as described in the instructions included with Maintenance Kit 2 (see Section 5).

**Key to the maintenance plan**

VE = Perform maintenance before switching the system on

t = Daily maintenance

6m = Maintenance every 6 months

a = Annual maintenance

n-a = Maintenance every n years

Every 3 years we recommend servicing of the pump involving the following steps:

- Cleaning
- Checking of individual components
- Exchange of all gaskets
- Functional check.

This check should be performed by the Leybold Service.

## 5 Maintenance and Repair Kits

The maintenance and repair kits have been so arranged that the spare and exchange parts they contain cover any servicing work which might be required.

Each set comes with brief instructions in which the necessary work is detailed. This very much simplifies the servicing or repair work.

Given in the following is a brief description of the individual kits and how to use these (in connection with the TRIVAC D 10 E, other pumps are similar)

### Maintenance Kit 1

This kit is recommended for maintenance after an operating period of one year. It contains the gaskets for the oil box, the internal demister which separates the oil from the gas (for contents see page 27, Fig. 11).

### Repair Kit 1

This kit is used for the seal on the side of the motor. It contains the gaskets for the side of the motor, the shaft sealing ring as well as the following wearing parts: coupling sleeves and compression spring for the oil pump (for contents see page 27, Fig. 12).

### Repair Kit 2

This set will only be required in those cases where the pump is not capable of attaining its ultimate pressure. This kit contains the valves, the internal demister which separates the oil from the gas as well as the gaskets for the oil box (for contents see page 28, Fig. 13).

### Maintenance Kit 2 / Repair Kit 3

These kits are identical. They contain all wearing parts, all gaskets and the internal demister which separates the oil from the gas.

They are used as follows:

1. Maintenance after three years of operation
2. Complete repair

(for contents see pages 27, 28 and 29, Fig. 12, 13 and 14).

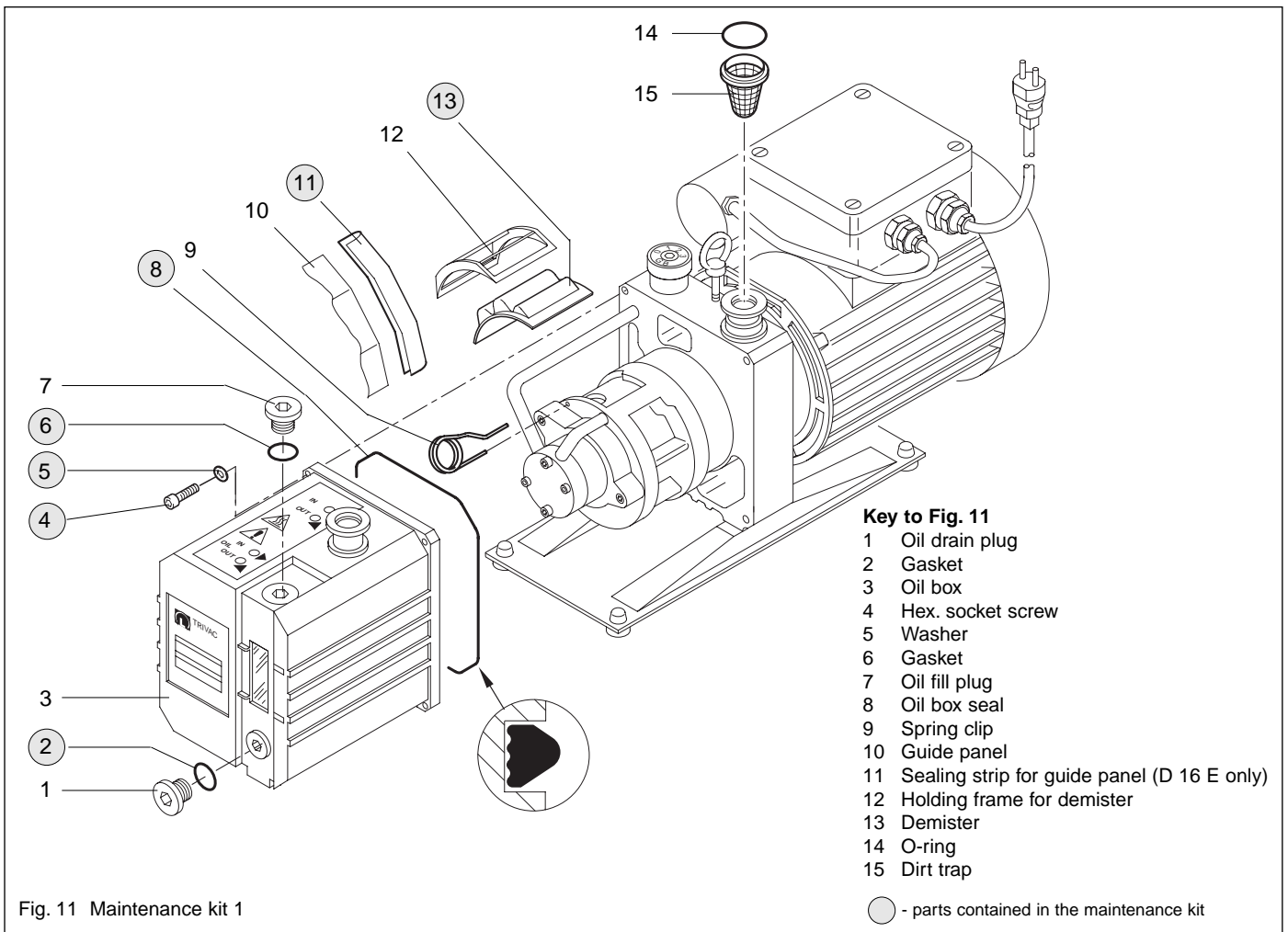

Fig. 11 Maintenance kit 1

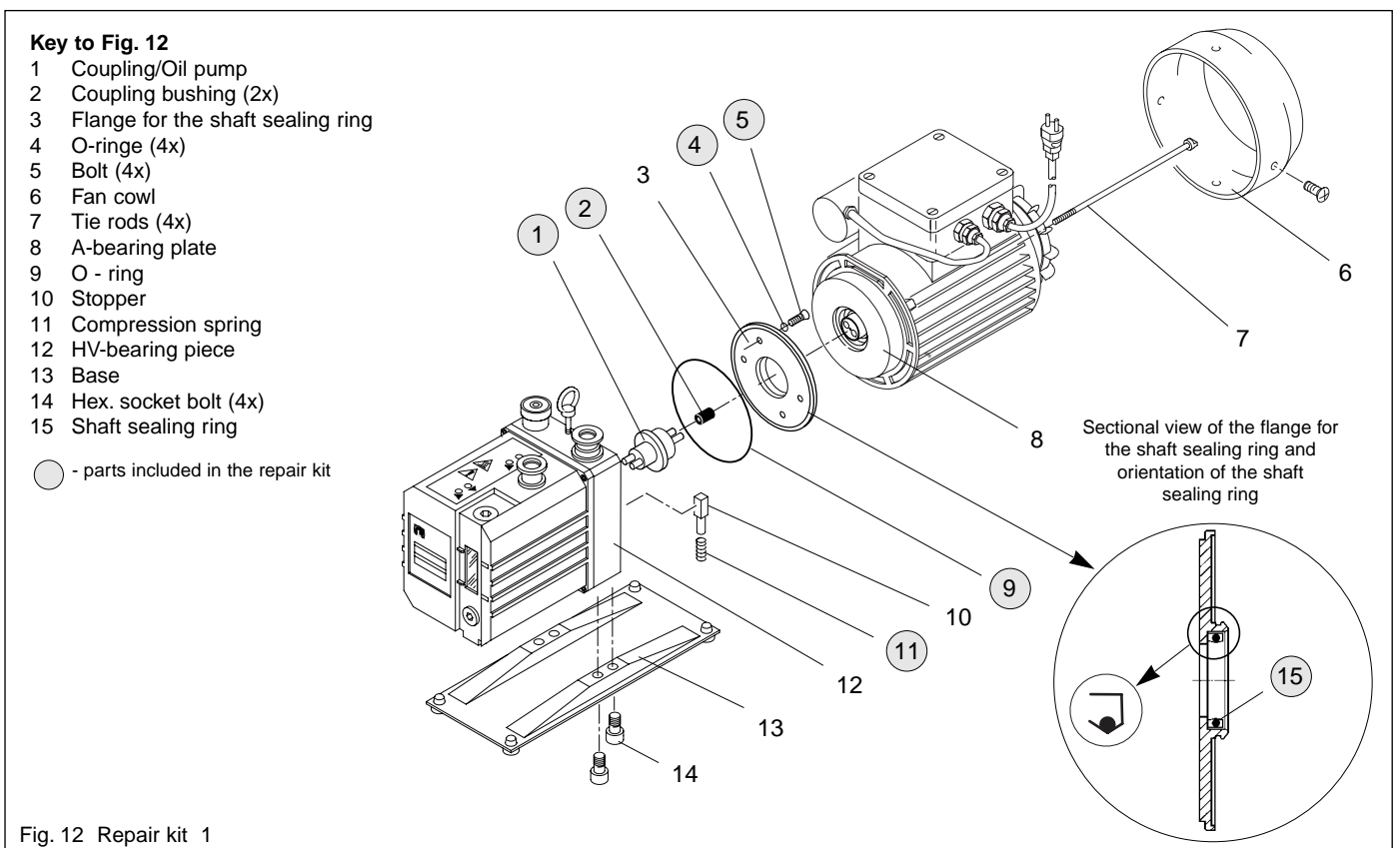
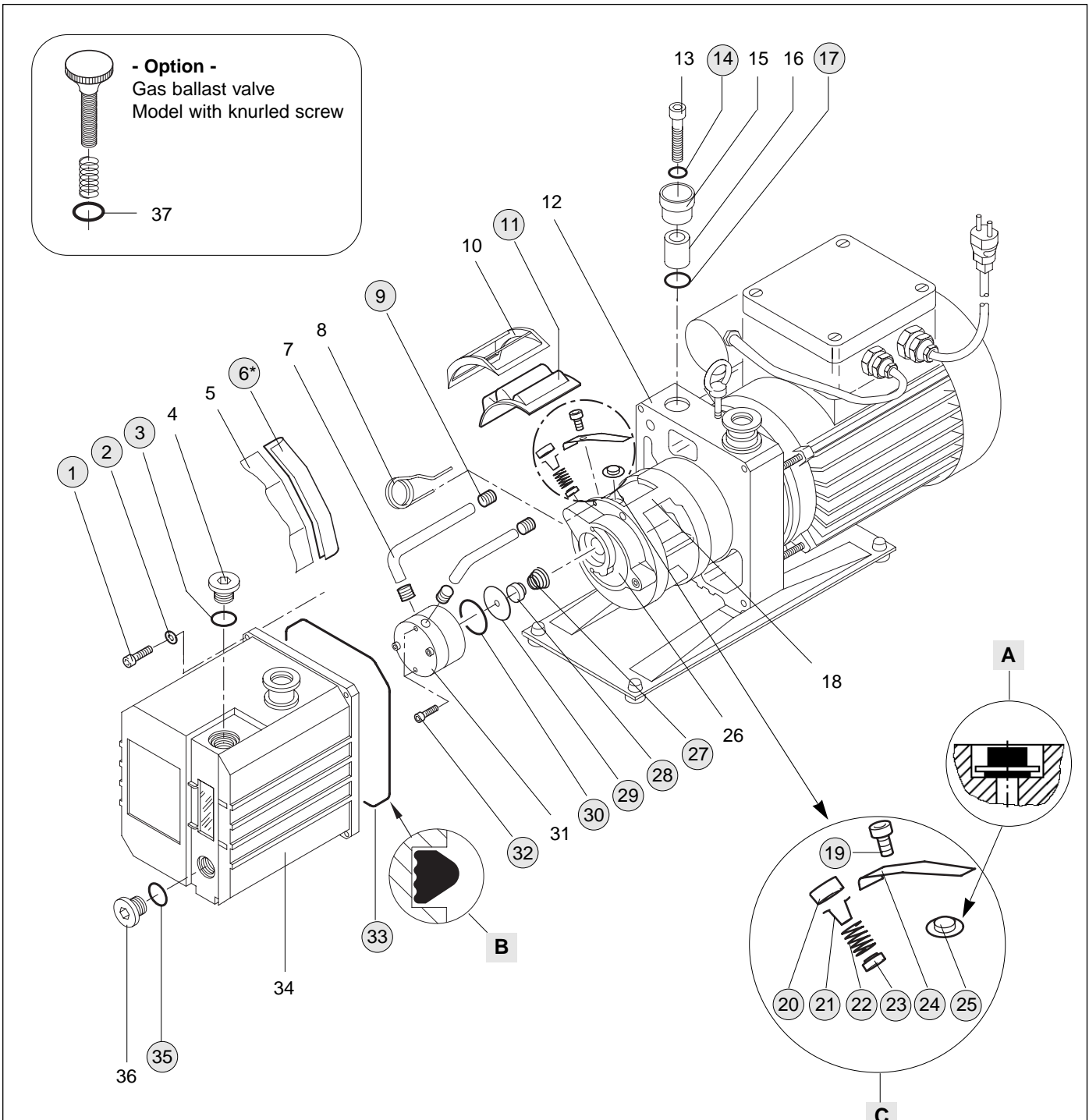

Fig. 12 Repair kit 1



**Key to Fig. 13**

- |                                  |                            |                        |
|----------------------------------|----------------------------|------------------------|
| 1 Hex. socket bolt               | 14 Flat gasket             | 27 Compression spring  |
| 2 Washer                         | 15 Gas ballast valve - cap | 28 Non-return valve    |
| 3 Gasket                         | 16 Gas ballast valve       | 29 Gas ballast orifice |
| 4 Oil fill plug                  | 17 Flat gasket             | 30 O-ring              |
| 5 Guide panel                    | 18 Forevacuum pot          | 31 Diaphragm valve     |
| 6 Sealing strip for guide panel* | 19 Hex. socket bolt        | 32 Hex. socket bolt    |
| 7 Oil or gas ballast pipe        | 20 Valve holder            | 33 Oil box seal        |
| 8 Spring clip                    | 21 Restrictor              | 34 Oil box             |
| 9 Rubber insert (4x)             | 22 Compression spring      | 35 Gasket              |
| 10 Holding frame for demister    | 23 Sealing element         | 36 Oil drain plug      |
| 11 Demister                      | 24 Valve bracket           | 37 Gasket              |
| 12 HV bearing piece              | 25 Bypass valve            |                        |
| 13 Hex. socket bolt              | 26 End disk                |                        |

\* D 16 E only

○ - parts contained in the repair kit

Fig. 13 Repair kit 2

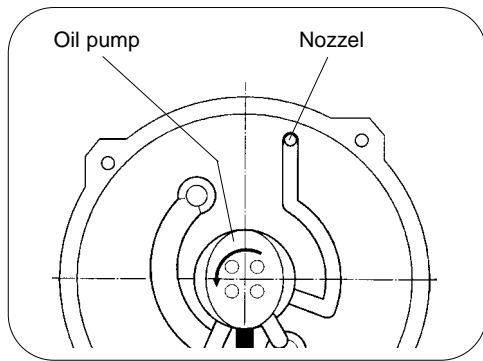

View "G"

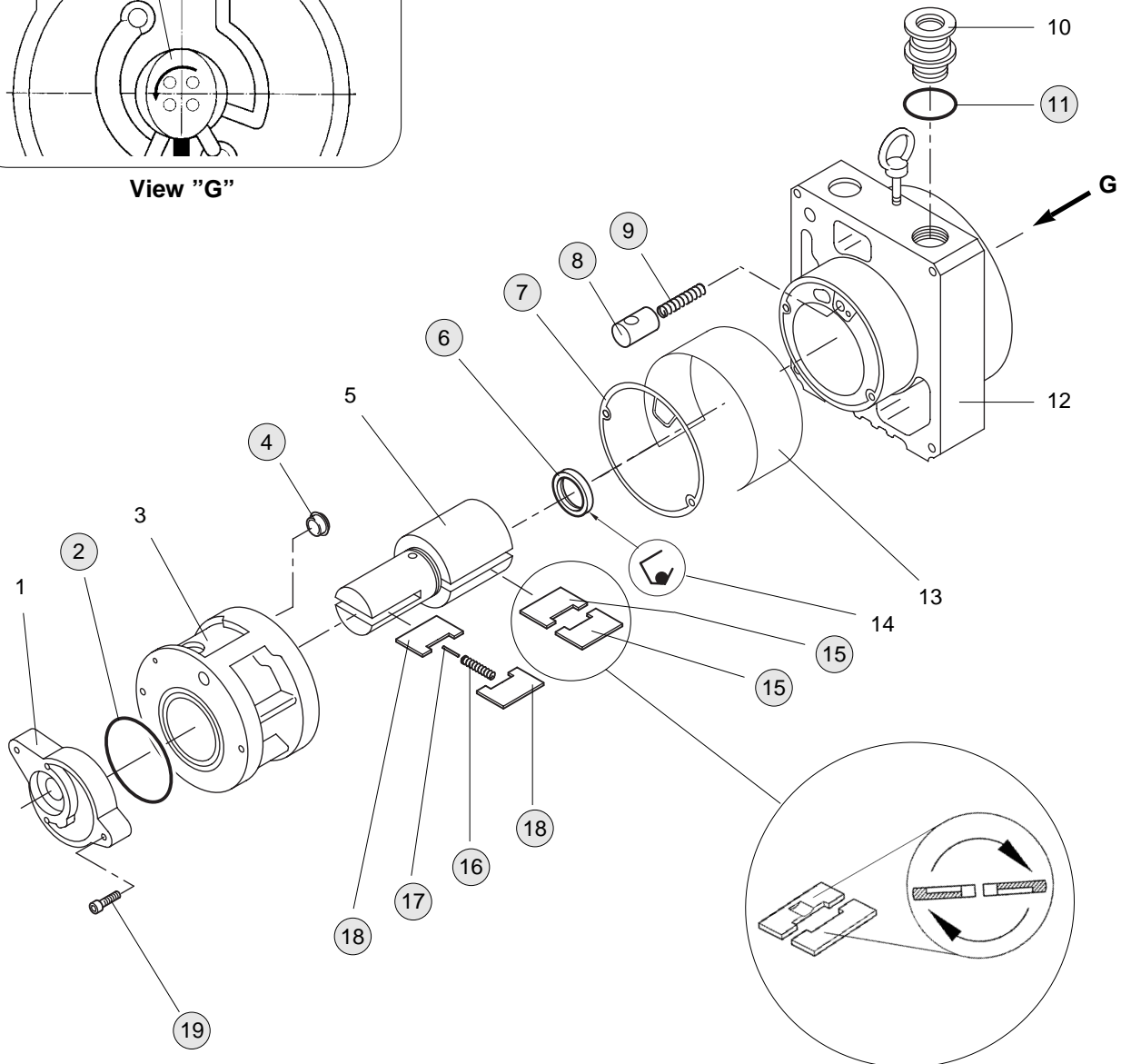

Enlarged view F  
Position of the HV vanes

**Key to Fig. 14**

- |                      |                                |
|----------------------|--------------------------------|
| 1 End plate          | 11 O-ring                      |
| 2 O-ring             | 12 High vacuum bearing piece   |
| 3 Forevacuum pot     | 13 Oil guiding panel           |
| 4 Sealing nipple     | 14 Position/shaft sealing ring |
| 5 Rotor              | 15 Vane (HV)                   |
| 6 Shaft sealing ring | 16 Compression spring          |
| 7 Flat seal          | 17 Guide pin                   |
| 8 Tandem valve       | 18 Vane (FV)                   |
| 9 Compression spring | 19 Hex. socket bolt            |
| 10 Intake port       |                                |

○ - Parts included in the complete kit

Fig. 14 Complete kit

## 5.1 Ordering Information for the Maintenance Kits and the Repair Sets

TRIVAC	D 5 E 2	D 10 E 2	D 16 E 2
Maintenance Kit 1	200 40 023	200 40 023	200 40 044
Maintenance Kit 2	E 100 000 348	E 100 000 349	E 100 000 350
Repair-Set 1	E 100 000 352	E 100 000 352	200 40 043
Repair-Set 2	200 40 054	200 40 054	200 40 056
Repair-Set 3	E 100 000 348	E 100 000 349	E 100 000 350

The use of the Maintenance Kits and the Repair Sets is detailed in the Tables 4 - Troubleshooting and 5 - Maintenance Plan.

## 5.2 Ordering Information for the Special Tools

TRIVAC	D 5 E 2	D 10 E 2	D 16 E 2
Special tool for the tie rods	_____	200 02 760	_____

# 6 Troubleshooting

Fault	Possible cause	Remedy	Repair*
Pump does not start up.	Faulty wiring. Motor protection switch not set correctly. (three-phase motors only) Power supply voltage does not match the rating of the motor. Motor faulty. Oil temperature less than 12 °C. Oil is too thick. Exhaust filter or exhaust line is clogged. Pump has seized (Sign: blocked pump).	Check the wiring and repair it. Properly set up the motor protection switch.  Exchange the motor. Exchange the motor. Warm up the pump and the oil of the pump or use a different oil. Change the oil. Exchange the filter or clean the exhaust line. Repair the pump.	- 2.3.2  3.5 3.5 2.5.3/3.2 3.2 - Service
Pump does not attain its ultimate pressure.	Method of measurement or measuring instrument not suitable.  External leak <sup>1)</sup> . Dirty internal demister. Faulty exhaust valve. Unsuitable oil. Intake line dirty or leaky. Pump too small.	Use the right method of measurement or measuring instrument. Measure the pressure directly at the intake port of the pump. Repair the pump. Perform maintenance. Repair the valve. Change the oil (possibly degas it). Clean or exchange the intake line. Check process data, possibly change the pump.	-  Service Main.kit1/2.3.5 Rep.-Set 2 3.2 - -
Pumping speed of the pump is too low.	Dirt trap in the intake line is clogged.  Clogged exhaust filter. Connection lines too narrow or too long.	Clean the dirt trap. Preventive action: install a dust filter in the intake line. Exchange the filter element. Use sufficiently wide and short intake lines.	3.3  - 2.2
After switching the pump off the pressure in the system increases to fast.	System has a leak. Faulty tandem valve. Inner shaft seal is faulty. Faulty exhaust or bypass valve.	Check the system. Repair the valve. Exchange the shaft seal. Repair the valve(s).	- Rep. Set 3 Rep. Set 3 Rep. Set 2
Pump gets hotter than previously observed.	Supply of cooling air is obstructed. Ambient temperature is too high. Process gas is too hot. Not enough oil. Unsuitable oil. Oil circulation is obstructed. Clogged exhaust filter or exhaust line. Exhaust valve faulty. Deviating mains supply voltage.	Properly install the pump. Properly install the pump. Change the process. Fill in oil. Change the oil. Clean or repair the oil channels. Exchange the exhaust filter, clean the exhaust line. Repair the valve. Check power supply rating of the motor and the mains supply.	2.1 2.1/2.5.3 -  Service - Rep. Set 2
Oil in the intake line or the vacuum chamber.	Oil coming from the system. Blocked tandem valve.	Check the system. Clean the valve or repair it.	- Rep. Set 3
Oil is turbid.	Condensation.	Degas the oil or change the oil and clean the pump. Preventive action: open the gas ballast valve or fit a separator.	2.5.2/3.2
The pump is extremely loud.	Oil level is much too low (oil is no longer visible). Intake pressure is too high. Clogged internal demister. Coupling bushings worn out. Damaged vanes or bearings. Faulty motor bearing.	Top up some oil. Reduce the intake pressure. Clean or replace the internal demister. Replace the coupling bushings. Repair the pump. Exchange the motor bearing.	3.2 - 3.4/Maint.Kit 1 Rep. Set 1 Service Service
Oil leak at the side of the motor	Outer shaft seal damaged or worn out.	Exchange the shaft seal.	Rep. Set 1

\*Descriptions relating to the repairs or maintenance work have been included with the respective maintenance kits or repair sets. For ordering information please refer to Section 5.1.

<sup>1)</sup> Bubble test: The warm pump with degassed oil is running without gas ballast with the intake blanked off. The exhaust line is lead into a vessel containing water. If an evenly spaced row of bubbles appears, then the pump has developed an external leak.

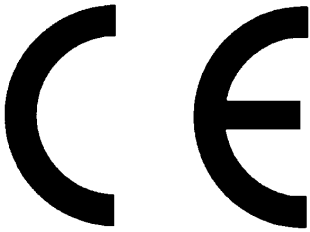

## EC Declaration of Conformity

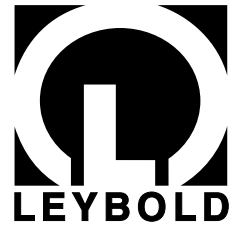

We - Leybold Vacuum GmbH - herewith declare that the products defined below meet the basic requirements regarding safety and health of the relevant EC directives by design, type and versions which are brought into circulation by us.

In case of any product changes made without our approval, this declaration will be void.

Designation of the products: Rotary vane pump  
dual stage

Models: TRIVAC E;  
D 5 E / D 10 E / D 16 E

Product numbers: 140 030 to 140 055

### **The products conform to the following directives:**

- EC Directive on Machinery (98/37/EG)
- EC Directive on Low-Voltages (73/23)+(93/68/EWG)
- EC EMC Directive (89/336/EWG)  
(91/263/EWG) + (92/31/EWG) + (93/68/EWG)

### **Applied harmonised standards:**

- DIN EN 292 Part 1 11.91
- DIN EN 292 Part 2 06.95
- DIN EN 1012 Part 2 07.96
- DIN EN 60 204 Part 1 11.98
- DIN EN 50 081 - Part 1 03.93
- DIN EN 50 081 - Part 2 03.94
- DIN EN 50 082 - Part 1 11.97
- DIN EN 50 082 - Part 2 02.96

### **Applied national standards and technical specifications:**

- DIN 31 001 April 1983

Cologne, July 07, 2001

K. Kilian, Business Area Manager LPV  
Division Industrial

Cologne, July 07, 2001

Dr. Bahnen, Head of R&D LPV  
Division Industrial



# Sales Net worldwide

## AMERICA

### USA:

*LEYBOLD VACUUM USA Inc.*  
5700 Mellon Road  
Export, PA 15632-8900  
Phone: +1-724-327 57 00  
Fax: +1-724-733 12 17  
Internet: <http://www.leyboldvacuum.com>

### Canada:

*LEYBOLD Canada Inc.*  
7050 Telford Way, Unit 5  
Mississauga, Ontario  
Canada L5S 1V7  
Phone: +1-905-672 77 04  
Fax: +1-905-672 22 49  
e-mail: [reachus@leybold.on.ca](mailto:reachus@leybold.on.ca)

## EUROPE

### Germany:

*LEYBOLD VAKUUM GmbH*  
Bonner Straße 498  
D-50968 Köln  
Phone: +49-(0)221-347-12 34  
Fax: +49-(0)221-347-12 45  
Internet: [www.leyboldvac.de](http://www.leyboldvac.de)  
e-mail: [sales@leyboldvakuu.com](mailto:sales@leyboldvakuu.com)

### Belgium/Netherlands/ Luxembourg:

*LEYBOLD N.V.*  
Leuvensesteenweg 542, 9A  
B-1930 Nossegem-Zaventem  
Phone: +32-2-71 10 083  
Fax: +32-2-72 08 338

### LEYBOLD VACUUM

*Nederland B.V.*  
Computerweg 7  
NL-3606 AV Maarssen  
Phone: +31-346-583 999  
Fax: +31-346-583 990

### France:

*LEYBOLD VACUUM France S.A.*  
7, Avenue du Quebec  
Z.A. de Courtaboeuf, B.P. 42  
F-91942 Courtaboeuf Cedex  
Phone: +33-1-69 82 48 00  
Fax: +33-1-69 07 57 38  
e-mail: [leybold-vacuuum@leybold.fr](mailto:leybold-vacuuum@leybold.fr)

### Great Britain/Ireland:

*LEYBOLD VACUUM UK Ltd.*  
Waterside Way,  
Plough Lane  
GB-London SW 17 0HB  
Phone: +44-208-971 70 00  
Fax: +44-208-971 70 01  
e-mail: [sales@leybold.co.uk](mailto:sales@leybold.co.uk)

### Italy:

*LEYBOLD VACUUM Italia S.p.A.*  
Via Trasimeno 8  
I-20128 Milano  
Phone: +39-02-27 22 31  
Fax: +39-02-27 20 96 41

### Spain:

*LEYBOLD VACUUM España S.A.*  
C/. Mataró,  
27 Poligono Industrial Les  
Grases  
E-08980 Sant Feliu de  
Llobregat (Barcelona)  
Phone: +34-93-666 46 16  
Fax: +34-93-666 43 70

### Sweden:

*LEYBOLD VACUUM Scandinavia AB*  
Datavägen 57 B  
Box 9084  
S-40092 Göteborg  
Phone: +46-31-68 84 70  
Fax: +46-31-68 39 39

### Switzerland/ Liechtenstein:

*LEYBOLD VAKUUM Schweiz AG*  
Leutschenbachstraße 55  
CH-8050 Zürich  
Phone: +41-1-308 40 50  
Fax: +41-1-302 43 73

## ASIA

### P.R. China:

*LEYBOLD (Tianjin) VACUUM Equipment Manufacturing Co. Ltd.*  
Beichen Economic Development Area (BEDA)  
Beichen District  
Tianjin 300 400  
Phone: +86-22 26 972 016  
Fax: +86-22 26 972 017  
e-mail: [leybold@public.tpt.tj.cn](mailto:leybold@public.tpt.tj.cn)

### Japan:

*LEYBOLD VACUUM Japan Co. Ltd.*  
Head Office  
Tobu AK Bldg. 3-23-3  
4th Floor,  
Shin-Yokohama  
Kohoku-ku, Yokohama-shi  
Kanagawa-ken 222  
Phone: +81-45-471 33 30  
Fax: +81-45-471 33 23

### Korea:

*Korea Ltd.*  
4th Fl. Shinahn Bldg., 173-1  
Jangchung-Dong 2-Ga,  
Chung-Ku  
Seoul 100-392  
C.P.O. Box 709  
South Korea  
Phone: +82-2-227 11 567  
Fax: +82-2-227 11 568

### Singapore:

*LEYBOLD Singapore Pte. Ltd.*  
1 Tuas South Street 3  
Singapore 638043  
Phone: +65-865 18 65  
Fax: +65-862 22 95

### Taiwan:

*LEYBOLD Taiwan Ltd.*  
2 F, No. 416-1, Section 3  
Chung Hsing Road  
Chutung HsinChu  
Taiwan R.O.C. 310  
Phone: +886-3-583 39 88  
Fax: +886-3-583 39 99



## LEYBOLD VAKUUM GmbH

Bonner Strasse 498 (Bayenthal)  
D-50968 Cologne

Tel.: + 49 (221) 347-0

Fax: + 49 (221) 347-1250

<http://www.leyboldvac.de>

e-mail: [documentation@leyboldvac.de](mailto:documentation@leyboldvac.de)