

Vacuum Solutions

Application Support

Service



LEYBOLD VACUUM

GA 05.139/1.02



PTB
SALES

FOR SALES AND SERVICE PLEASE CALL:
PTB SALES T : 866.332.0500
F : 626.334.2151
www.ptbsales.com

DATE SERVICED: _____



MAG W 2010 CHT

Turbomolecular Pump
with Magnetic Bearing

MAG.DRIVE 2000

Electronic Frequency
Converter

Software version 1.4.xx

Cat. Nos.
121 31
121 44

Operating Instructions

Contents	Page
1 Description	3
1.1 System overview	3
1.2 Compatibility with pumped media	4
1.3 Design of the MAG	4
1.4 Function and design of the MAG.DRIVE	5
1.5 Standard specification	6
1.6 Technical data	6
1.7 Ordering information	8
2 Installation	13
2.1 General safety information	13
2.2 Unpacking - storing - transportation	13
2.3 Operating environment	14
2.4 Connecting the MAG to the vacuum chamber	14
2.5 Connecting the backing pump	19
2.6 Connecting the cooling water	20
2.7 Connecting the purge gas	22
2.8 Installing the MAG.DRIVE	24
2.8.1 Power supply connection X10	25
2.8.2 Pump connection	26
2.8.3 Control plug X14	27
2.8.4 Interface connector	31
3 Operation	32
3.1 General operation rules	32
3.2 Operation with the START and STOP keys .	34
3.3 Remote control	35
4 Plug-in Control	36
4.1 Operation with plug-in control	36
4.2 Operating statuses	38
4.3 Operating menu	40
4.3.1 Basic menu	40
4.3.2 Settings converter	41
4.3.3 Settings pump	42
4.3.4 Settings temperature management system .	42
4.3.6 Total view of the menu	43
4.4 Temperature management system	44
5 Maintenance	46
5.1 Removing the pump from the system	46
5.2 Service at Leybold's	48
6 Troubleshooting	50
6.1 Warning messages	50
6.2 Failure messages	52
6.3 Malfunctions	57
Certifications	58
Forms	64

Figures

The references to diagrams, e. g. (1/2) consist of the Fig. No. and the Item No. in that order.

We reserve the right to alter the design or any data given in these Operating Instructions. The illustrations are not binding.

The Operating Instructions are included with the pump **and** the converter. If they have different numbers, the version delivered with the pump describes the pump correctly and the version delivered with the converter describes the converter correctly.

Concerning the **converter** description, this GA 05.139/1.02 is nearly identical to GA 05.135/3.02 for the standard MAG versions.

See also the last page.

1 Description

1.1 System overview

The Leybold **MAG** pumping system consists of:

- The **MAG W 2010 CHT** turbopump

The MAG are turbomolecular pumps utilizing magnetic bearings. They are designed to evacuate vacuum chambers down to pressure values in the high-vacuum range and to pump high gas throughputs.

The pump design allows high temperatures (HT) at the connection flanges without reduction of the maximum gas throughput.

- The **MAG.DRIVE 2000** frequency converter

The electronic converter converts the single-phase line supply voltage into a three-phase DC voltage to drive the pump motor. It also evaluates measured signals and controls

- the pump functions
- the temperature management system (TMS) and
- the active magnetic bearing system

The MAG.DRIVE 2000 can be operated with the START and STOP keys, via a plug-in control, or via a network interface.

- A **cable set** consisting of:
 - BEARING cable
 - DRIVE/TMS cable

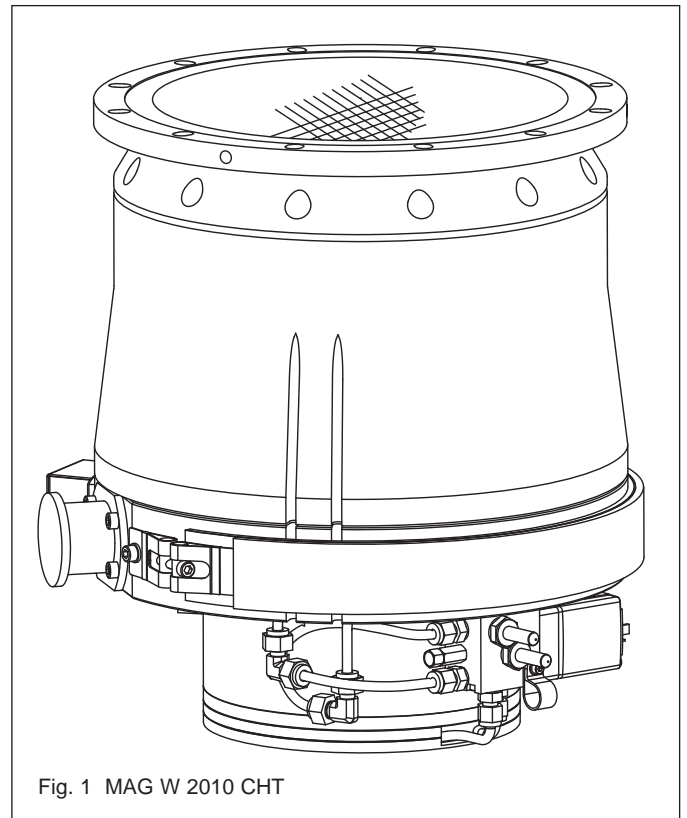

Fig. 1 MAG W 2010 CHT

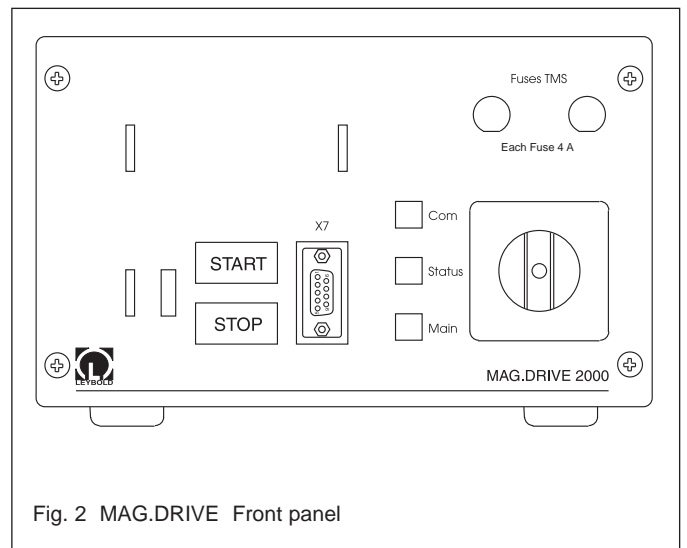

Fig. 2 MAG.DRIVE Front panel

1.2 Compatibility with pumped media

The MAG W 2010 CHT is specifically designed for the needs of the semiconductor industry.

All materials used inside the pump are compatible with typical gases used for semiconductor processes. Typical gases are: Cl_2 , HBr , HF , SF_6 , Halocarboncompounds, NF_3 , SiH_4 , SiH_2Cl_2 , PH_3 , AsH_3 , P , As .

Caution

Please consult Leybold regarding the media which can safely be handled with this unit.

Corrosion protection

To protect the pump from corrosive gases it is mandatory to use dry Nitrogen purge during operation of the pump. The purge gas protects the bearing section and the motor from corrosive gases.

The rotor and the stator of the pump are KEPLA®-coated to prevent corrosive attack caused by the process gases. The corrosion protection of the pump is effective only when the pump is protected from moisture during standstill and storage. If the process gas contains moisture, contact Leybold for recommendations.

Sublimation

Some media (e.g. AlCl_3) can sublime in the pump and form deposits. Thick coatings can infringe on the required operating clearance and ultimately cause the pump to seize. These deposits can also react with moisture and generate corrosive gases (e.g. HCl). This can become very critical when the pump is exposed to air. Deposits can be avoided in many processes by heating the pump with TMS (Temperature Management System).

The TMS is integrated in all CHT-versions. The purpose of the TMS is to keep the baseflange temperature in a constant range. To achieve the temperature the pump is equipped with a heaterband.

Some media (e.g. metall organic compounds) can decompose at the hot surface of the pump and build layers. Please direct any inquiries to the manufacturer.

Caution

In order to handle gases or media (e.g. AlCl_3 , WOCl_4) which can form deposits inside the pump it is required to use the TMS (Temperature Management System). The temperature selected for such processes has to be set to the maximum value (62°C).

Ignition danger

During operation the pressure inside the MAG is so low that there is no danger of ignition (at pressures below about 100 mbar). A hazardous condition will be created if flammable mixtures enter the hot pump at pressures above 100 mbar. During operation the pump can reach temperatures as high as 120°C (248°F). If the pump is damaged, sparks could occur which could ignite explosive mixtures.

1.3 Design of the MAG

The MAG comprises basically the pump housing, the multistage rotor with the stator package, the drive, and a magnetic bearing.

Rotor

The rotor is made from a high strength aluminium alloy. The rotor and the stator plates are protected with a special ceramic layer (KEPLA-COAT®). The rotor is a multi-stage axial-flow turbine with a screw stage.

The rotor is machined from one piece and the geometry of the the blades is optimized for high compression and pumping speed of the typical gases used in semiconductor manufacturing processes (e.g. SF_6 , Ar , BCl_3).

Bearings

The MAG has a built-in precision 5-axis controlled magnetic bearing. The rotor is suspended by trouble-free magnets:

- along two orthogonal axes in each of two radial planes
- and completely in the axial direction

The bearing concept allows for low vibration operations and insures operation of the pump in any mounting position. Magnetic bearings also guarantee ultra-clean vacuum because no grease is used for lubrication of bearings.

Two touch down bearings are provided to stabilize the rotor mechanically if impacts occur during operation. They are only used in case of the breaking of the power supply or BEARING cable during operation, strong shocks, or faulty electronics.

Motor and control

A DC motor without commutator is used to power the rotor.

Drive voltage for the motor and the operating voltage for the magnetic bearing are supplied by the MAG.DRIVE frequency converter. It also handles the automatic monitoring of these systems.

The pump is equipped with a data storage device which stores the important operating parameters during the complete operation time of the pump.

The converter monitors continuously all important operating parameters and provides warning and alarm signals in case the operating conditions exceed the specification or the set threshold.

1.4 Function and design of the MAG.DRIVE

The MAG.DRIVE 2000 electronic converter is used to drive the MAG turbo-molecular pumps.

The electronic converter converts the single-phase line supply voltage into a three-phase DC voltage to control and monitor the electronically-commutated DC motor. It also evaluates measured signals and controls (open-loop and closed-loop) the pump functions.

The temperature management system (TMS) and the magnetic bearing control system are integrated into the converter. The TMS regulates the pump temperature by switching the heating on/off or cooling the pump. The magnetic bearing control system actively controls the pump rotor in five axes (closed-loop control).

All parameters required for pump operation and the listed faults and operating hours are stored in a non-volatile memory in the pump. When the converter is switched on, the data are loaded into the converter from the pump.

The outputs of the electronic converter are no-load and short-circuit proof.

For remote control via control connector X14 we recommend that either a relay or optocoupler is used to provide electrical decoupling.

Housing

The converter is supplied with a closed housing. It can be installed in a 19" cabinet; see Section 2.8.

Front panel

Main switch

9-pin connecting socket for the plug-in control or for connection of a serial interface

2 short-stroke keys

1 green/red STATUS LED

1 green COM LED (communications interface)

1 green MAIN LED (line supply voltage)

2 fuses TMS (Temperature Management System)

The optional plug-in control has 10 keys and 1 LCD with 2 lines, each 16 characters. The plug-in control displays operating statuses and failures and allows the configuration of the pumping system.

Rear panel

X14 50-pin D socket connector for remote monitoring and open-loop control

X19 3-pin Hirschmann connector for the connection to the mains supply

X20 55-pin MIL standard socket connector for internal sensors and magnetic bearing connection

X21 41-pin MIL standard socket connector for the motor, TMS, and purge valve connection

Spare slot for optional network cards, e.g. Device Net

1.5 Standard specification

MAG

The turbomolecular pumps are shipped complete, sealed in a PE bag containing a desiccant.

The maximum effective life time of the desiccant is one year.

The intake flange is sealed with a transport seal, the forevacuum flange with a plastic cap.

For the intake flange, a centering ring with FPM O-ring, outer ring, and a splinter guard are enclosed.

We also provide the bolts for attaching the pump to your tool. To avoid any safety risk we highly recommend using only the bolts provided with the pump. Refer also to Section 2.4 „Connecting the MAG ...“.

The electronic frequency converter MAG DRIVE as well as the cables required for operation must be **ordered seperately**.

In addition, a seal kit is included to seal the pump tightly if it is removed from the process.

MAG.DRIVE

- Converter
- Line supply cable with USA connector, approx. 3m
- Line supply cable with EURO connector, approx. 3 m
- 2 spare fuses for the TMS (miniature fuses 5 x 20 mm, F4A; according to IEC 127-2/1) and 2 fuse holders 6.3 x 30 mm
- Connector for control plug X14 (pins 47/48 bridged)

Cable Set

- BEARING cable
- DRIVE/TMS cable

1.6 Technical data

MAG W 2010 CHT

Pumping speed for N ₂ measured with splinter guard (PNEUROPO)	1650 l·s ⁻¹
Gas flow (continuous operation with Argon)	1300 sccm
Compression for N ₂	>10 ⁸
Ultimate pressure as to DIN 28 400	< 10 ⁻⁸ mbar
Max. forevacuum pressure with Nitrogen	3.5 mbar
with Argon	4.3 mbar
Rotor Speed	28,800 min ⁻¹
Run-up time	< 8 min
Braking time with/without venting	1 / < 7.5 min
Cooling	water
Cooling connection, Swagelok tube OD	1/4"
Cooling water temperature	10 to 30 °C 50 to 86 °F
Inlet pressure	2 to 6 bar (absolute) (i.e. 1 to 5 bar over atmosphere)
Base flange temperature (controlled)	30 to 62 °C 86 to 144 °F
Weight	approx. 65 kg
High-vacuum connection flange	DN 250 ISO-F
Max. high-vacuum flange temperature	85 °C 185 °F
Forevacuum connection flange	DN 40 KF
Recommended backing pump	DRYVAC 50
Admissible ambient temperature	5 to 40 °C 40 to 104 °F
Storage temperature	-10 to +60 °C 14 to 140 °F
Max. relative air humidity	95% (non-condensing)
Degree of protection (EN 60529)	IP 20

Purge Gas

Purge gas:	dry nitrogen, argon or similar
Purge gas throughput	0.5 to 0.65 mbar·l·s ⁻¹ 30 to 40 sccm
Connection: VCR Nut	1/4"

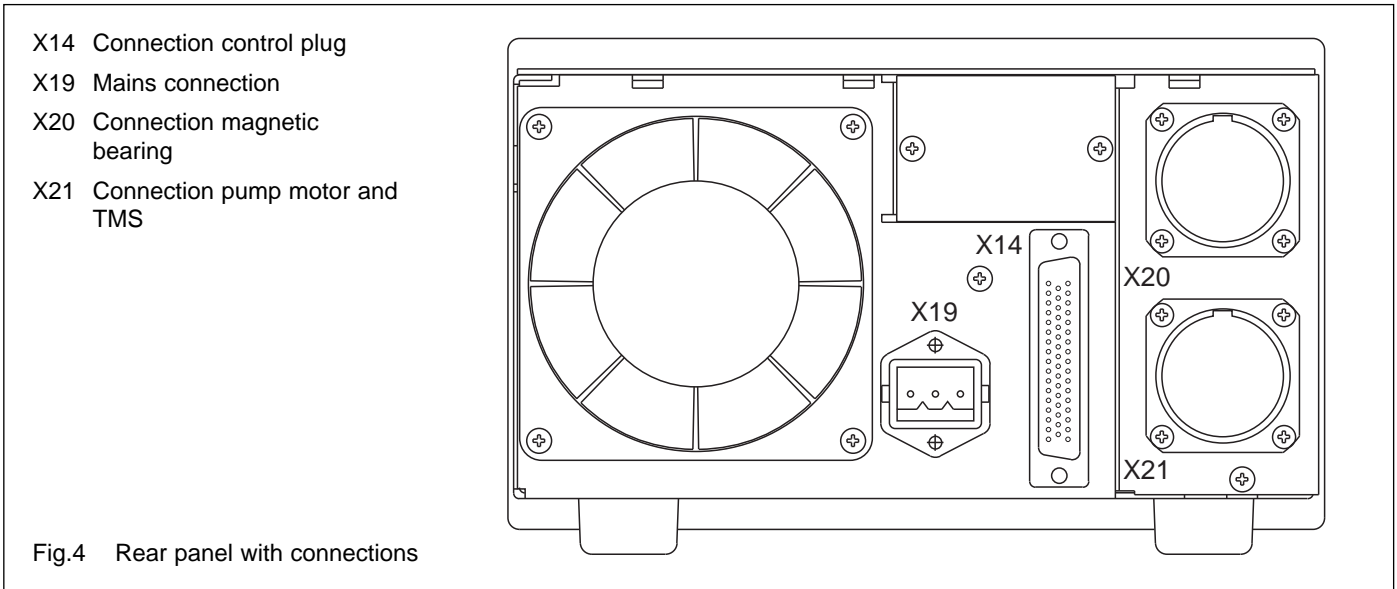
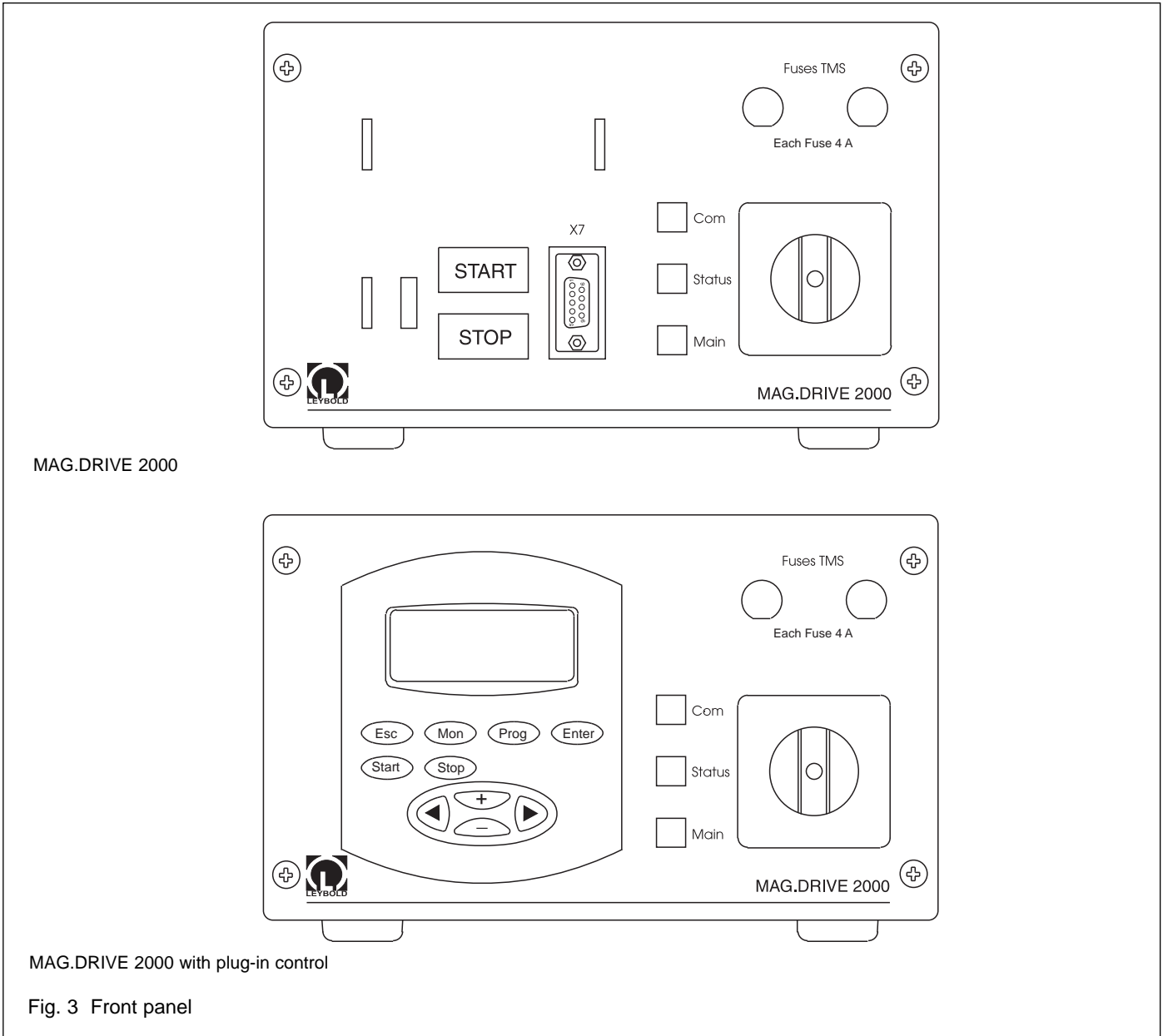

Technical data (continued)

MAG.DRIVE

Voltage range	200 - 240 V +10% -15%
Line supply frequency	50 / 60 Hz
Load	
Stand-by	approx. 100 W
Continuous (rated speed)	810 W
Maximum	1800 W
Max. voltage motor	60 V
Maximum pump current	20 A rms
Continuous pump current, max.	15 A rms
Maximum frequency	480 Hz
Load capability, relay output	42 V, 1 A
Temperature during operation	0-45° C
Storage temperature	- 10° C to + 60° C
Relative air humidity	Class F acc. to DIN 400 40
Overvoltage category	II
Contamination level	2
in accordance with EN 61010	
Weight	10 kg

The units have degree of protection IP20 in accordance with EN 60529

(protection against the ingress of solid foreign bodies > 12 mm diameter (finger). It is not protected against the ingress of water with damaging effects.)

An increased degree of protection, e.g. IP54 can only be implemented by mounting the converter in an additional housing.

1.7 Ordering data

	Order No.
MAG W 2010 CHT	121 31
Seal Kit DN 250 standard	200 91 641
Seal Kit DN 250 metal	200 07 901
MAG.DRIVE 2000 converter	121 35
MAG.DRIVE 2000 converter (AMAT part no.)	121 44
Plug-in control	121 36
MAG.DRIVE 2000 with DeviceNet	121 37
Connecting cables, converter — pump	see Fig.5
19" installation frame	161 00
Connector for hardware interface from 25 pins to 50 pins	on request
Purge/vent valve	121 33

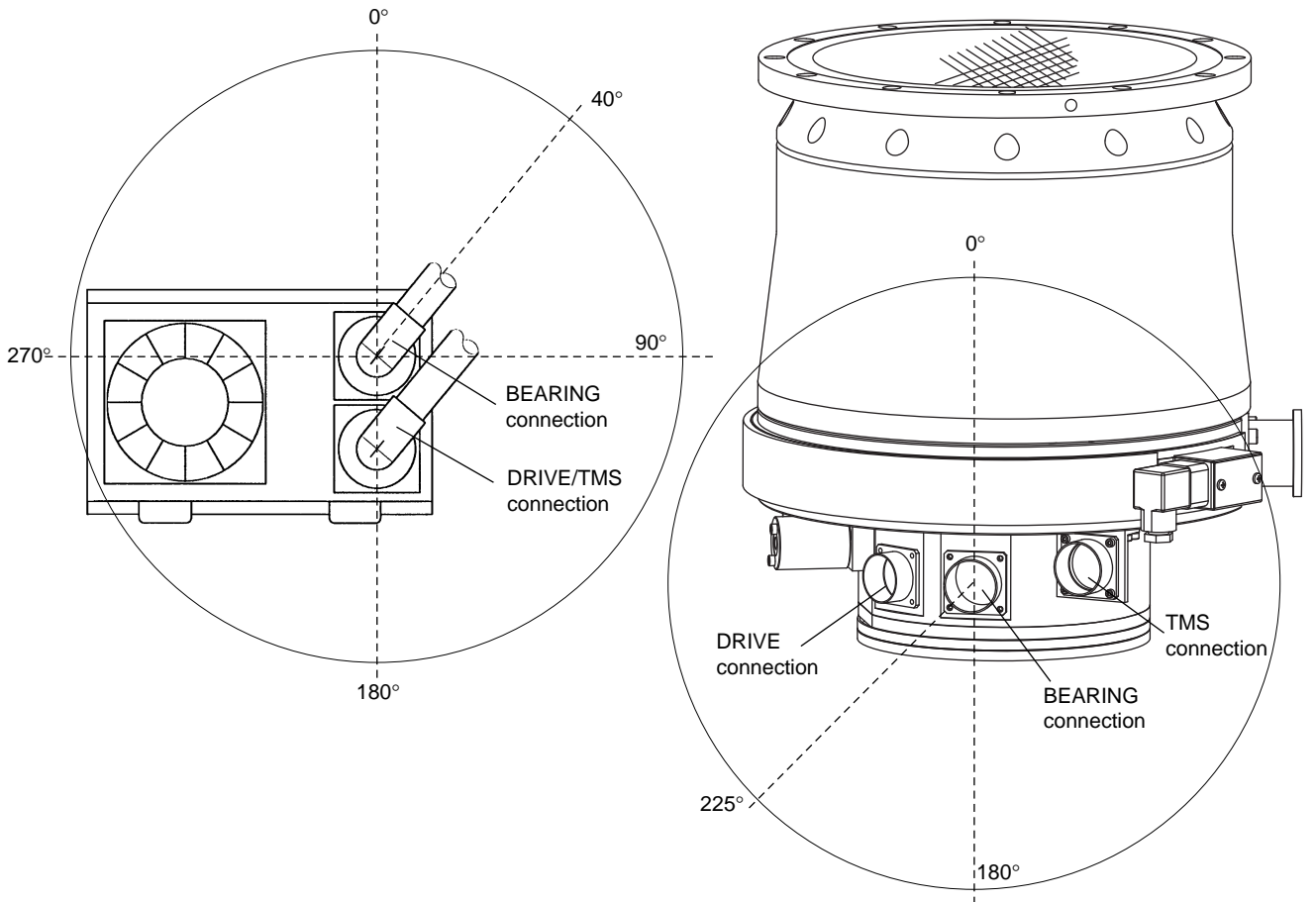

Connecting cables converter — pump

Length	Cable	Cable outlet Converter	Cable outlet Pump	Order No.
1.5 m	BEARING	bended 40°	bended 140°	121 29
1.5 m	DRIVE/TMS	bended 40°	bended 225° (DRIVE) bended 185° (TMS)	121 30
3 m	BEARING	straight	straight	121 17
3 m	DRIVE/TMS	straight	straight	121 18
5 m	BEARING	bended 225°	straight	121 19
5 m	DRIVE/TMS	bended 180°	straight	121 20
10 m	BEARING	bended 225°	straight	121 21
10 m	DRIVE/TMS	bended 180°	straight	121 22
20 m	BEARING	bended 225°	straight	121 25
20 m	DRIVE/TMS	bended 180°	straight	121 26
20 m	BEARING	bended 225°	bended 235°	121 45
20 m	DRIVE (only for MAG W 2010 C)	bended 180°	bended 235°	121 46

Fig. 5 Overview and ordering data for connecting cables

Description

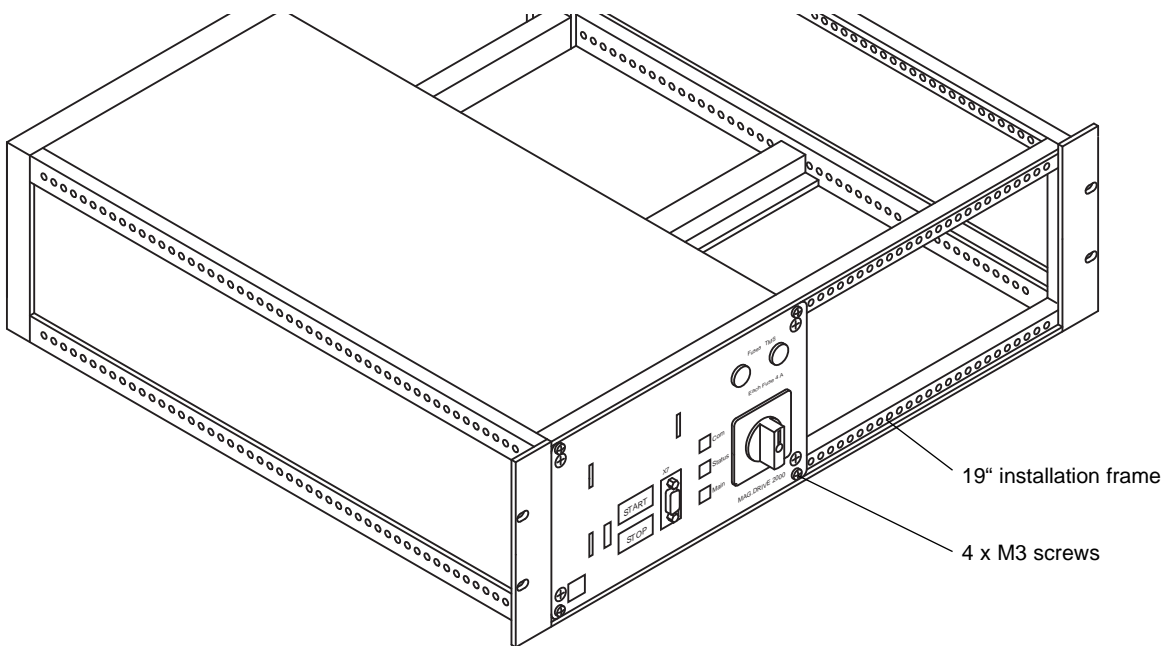
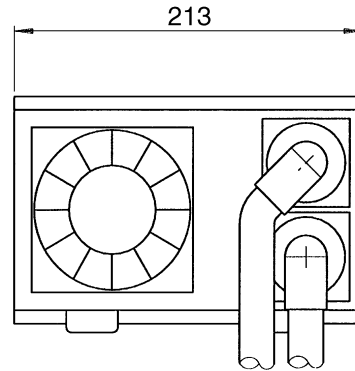
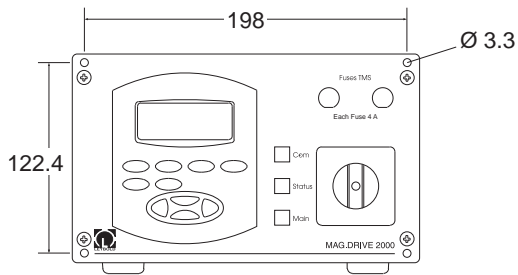
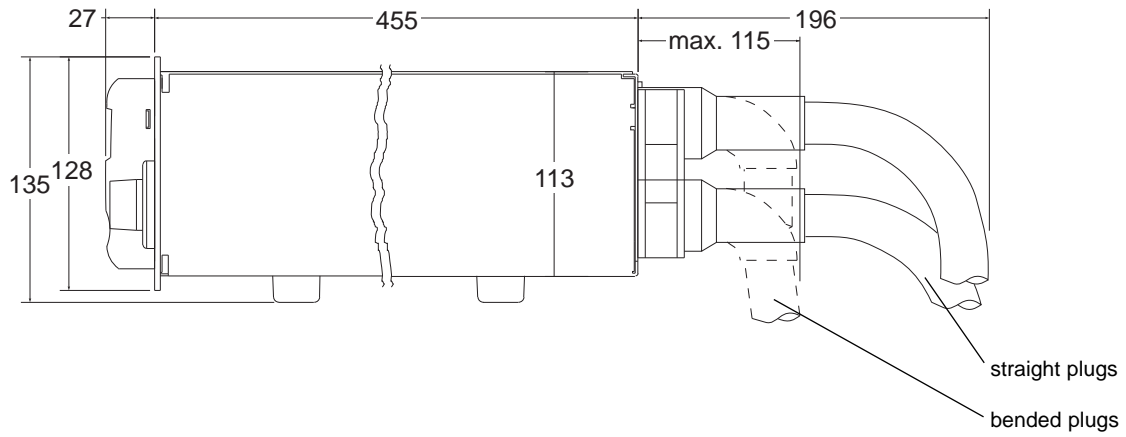
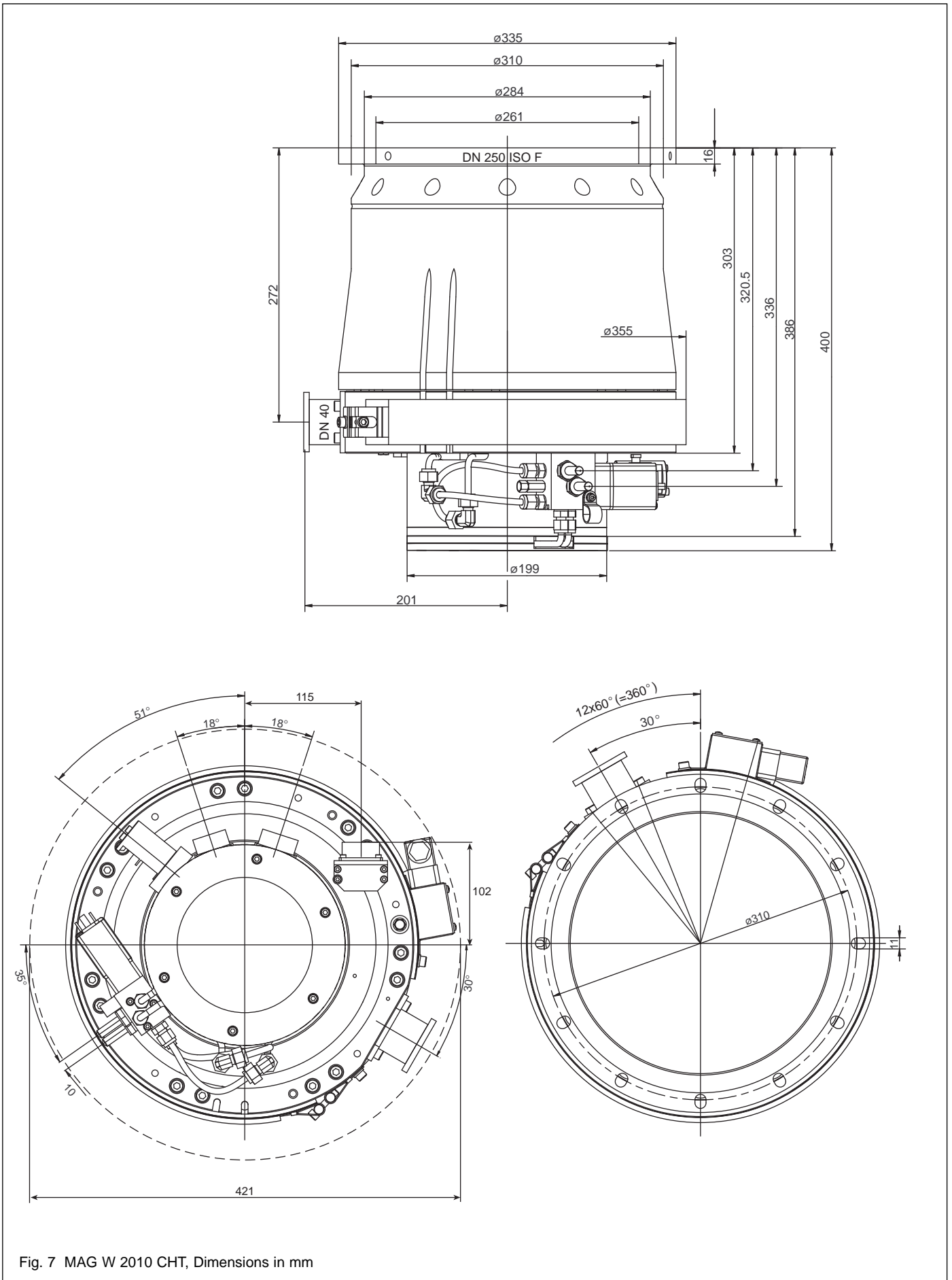
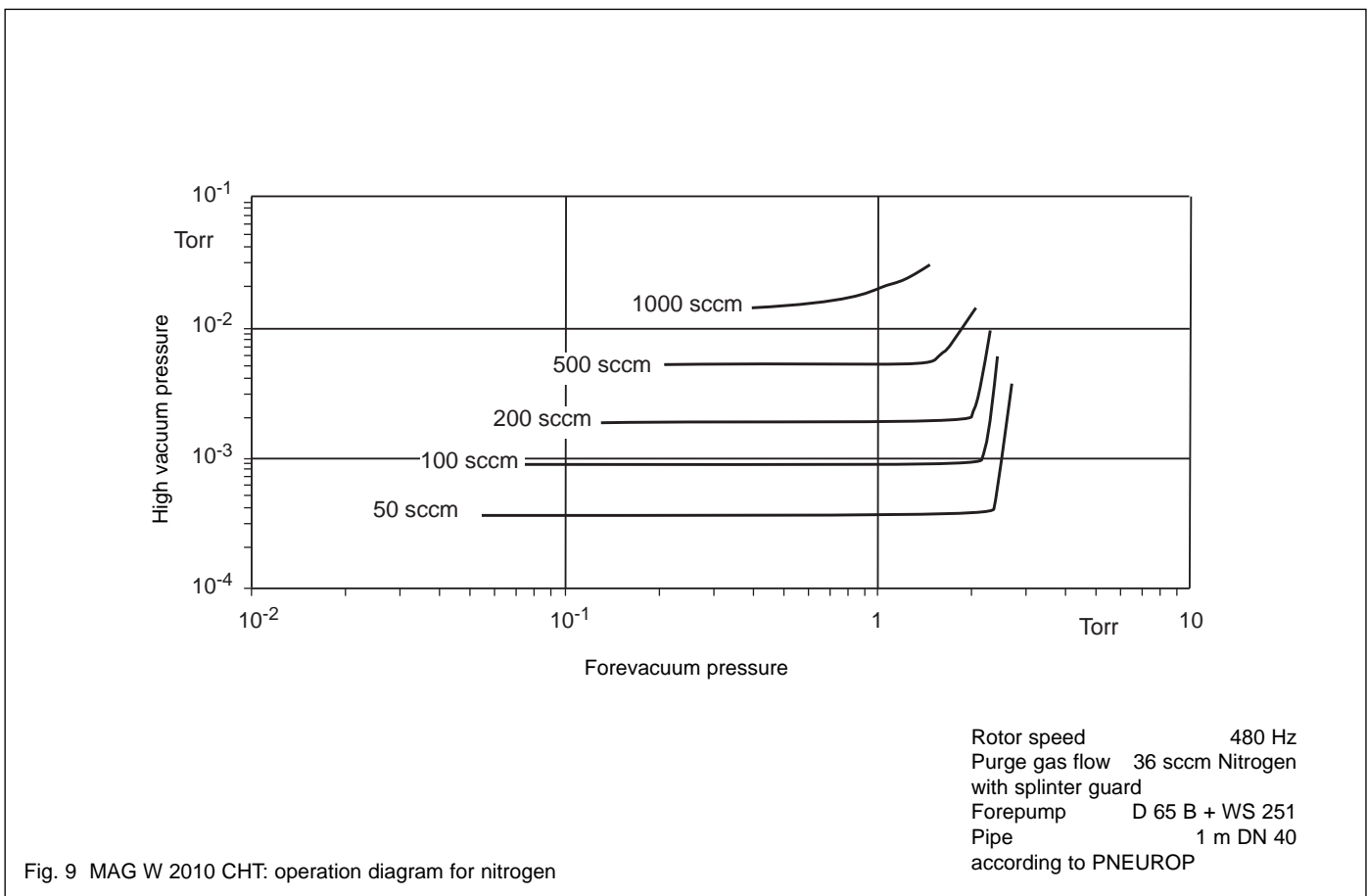
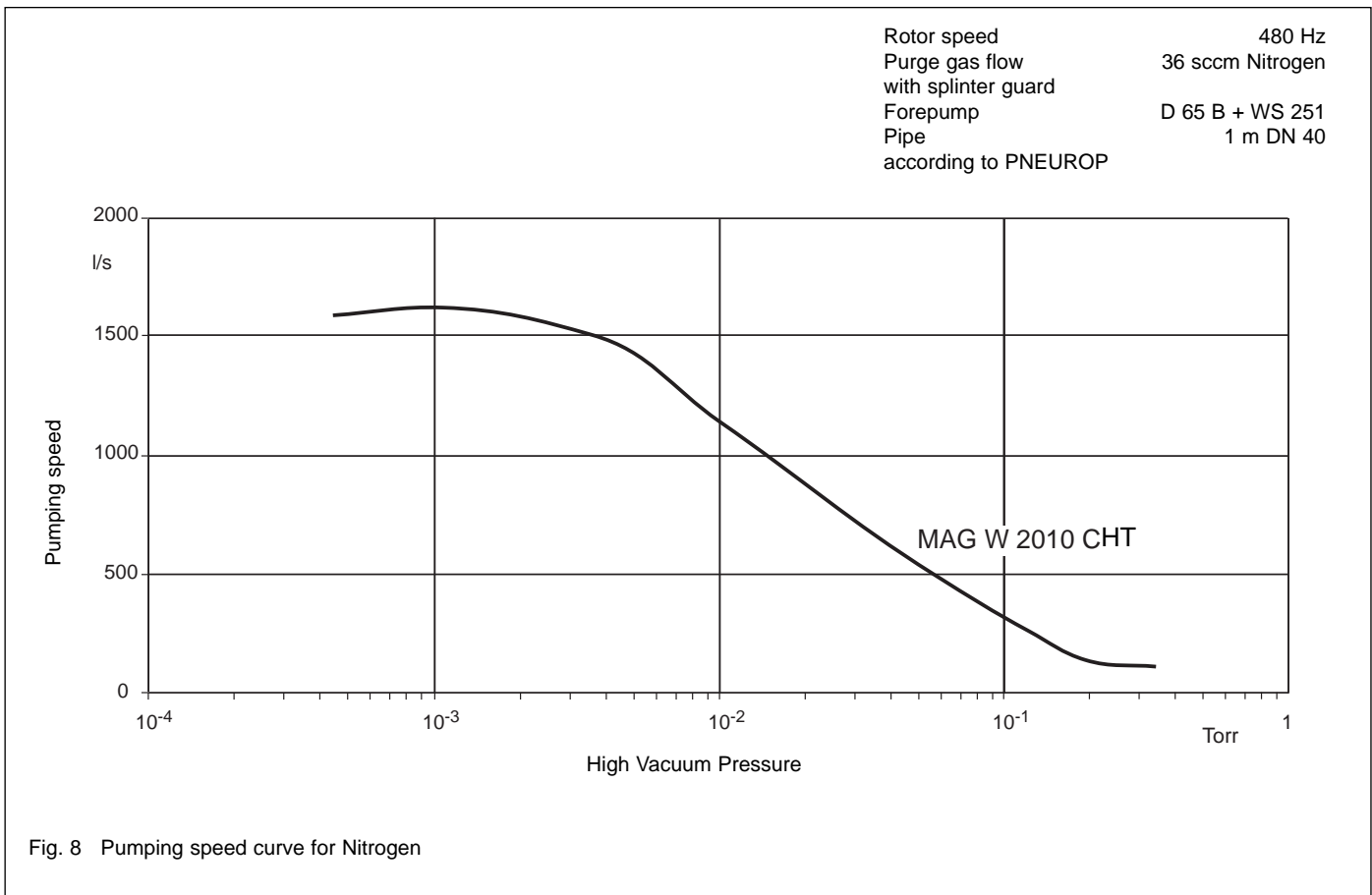

Fig. 6 Dimensional drawing and standard fixing of the MAG.DRIVE; dimensions in mm



Description



2 Installation

2.1 General safety information

Warning

Indicates procedures that must be strictly observed to prevent hazards to persons.

Caution

Indicates procedures that must be strictly observed to prevent damage to, or destruction of the MAG.

Warning



Never expose any parts of the body to the vacuum.

Warning



The converter has dangerous voltage levels.

Failure to strictly follow the instructions in this Manual can result in death, severe bodily injuries or significant material damage.



Only suitably qualified personnel are permitted to work on the pump or converter. Personnel must be completely knowledgeable of all warning information and measures which are specified in this Instruction manual for transporting, installing, and operating the unit.

Qualified personnel

Qualified electrical personnel in this instruction manual means a person who has received electrical engineering instruction or is an electrical expert in accordance with EN 60204, Part 1, 3.30 respectively 3.55.

Warning



The device contains electrostatically sensitive devices (ESD)!

Warning



Unauthorized opening of the converter voids the warranty.

Before opening the converter, always disconnect it from the mains and the pump!

Before disconnecting any cables make sure that the converter is switched off and the pump has come to a standstill.

When applying external voltage in excess of 42 V to terminals of the device, observe local safety regulations!

Unauthorized device conversion and modifications are prohibited for safety reasons.

Please keep this Operating Instruction for future reference.

2.2 Unpacking - storing - transportation

Remove the equipment from the transportation box and keep the packaging. Make sure that the product has not been damaged during transportation. If this unit is damaged contact your carrier and inform LEYBOLD if necessary. For storage of the product, use the packaging provided.

Lift the pump by the crane eyelets or move it with at least two persons.

You can position the pump on the base plate for transport with a lift-truck. Protect the pump against slipping and tipping over.

Caution

Be careful not to damage the sockets and coolant connections during transportation.

Do not stand below the pump while connecting or removing the MAG.

The MAG is shipped in a sealed PE bag with desiccant. Do not open the sealed package until immediately before installing.

Do not remove the covers and blanking flanges until you are ready to make the connections, to ensure that the MAG is installed under the cleanest possible conditions.

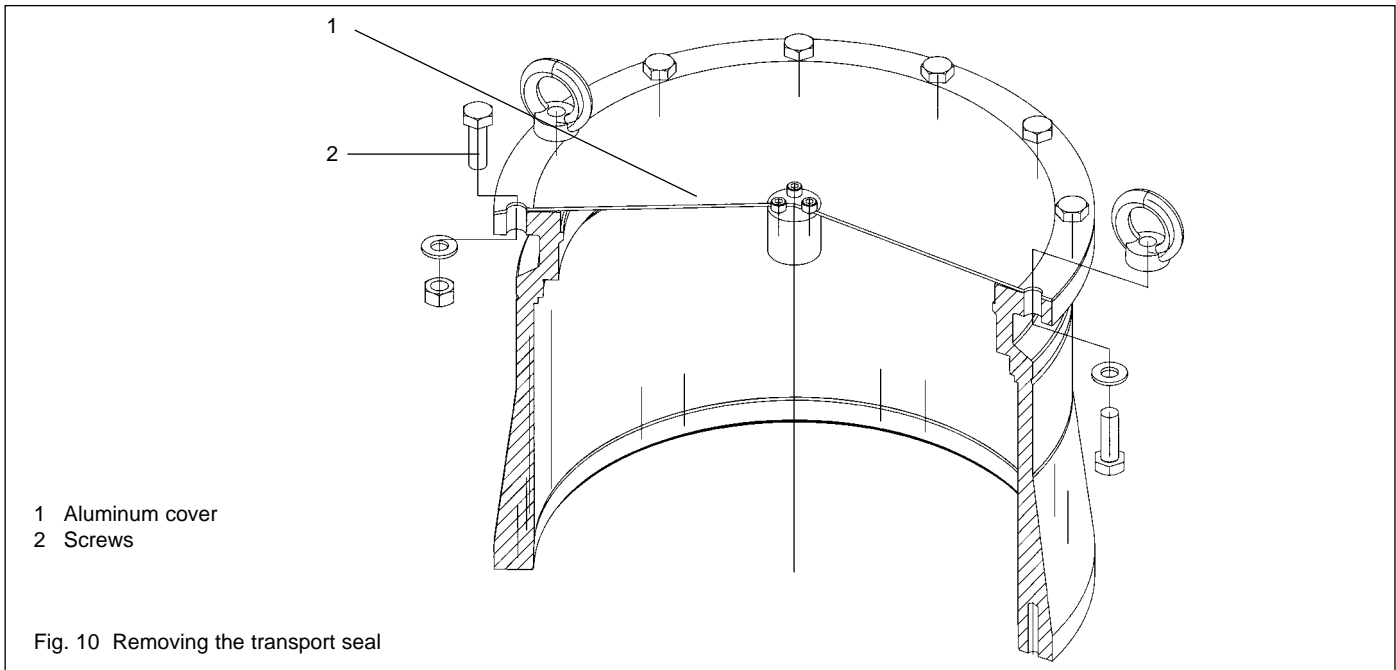

2.3 Operating environment

When using the MAG inside a magnetic field, the magnetic induction at the pump housing must not exceed 5 mT; (1 mT (milliTesla) = 10 G (Gauß))

Exceeding this limit can cause excessive rotor heating due to the eddy currents generated in this situation. It is therefore necessary to provide suitable shielding in such cases.

The standard version of the MAG is resistant to radiation at levels up to 10^3 Gy. (1 Gy (Gray) = 100 rad)

The ambient temperature must not exceed 40°C (104 °F).

The noise level when the pump is running is below 70 dB(A). No acoustic insulation is required.

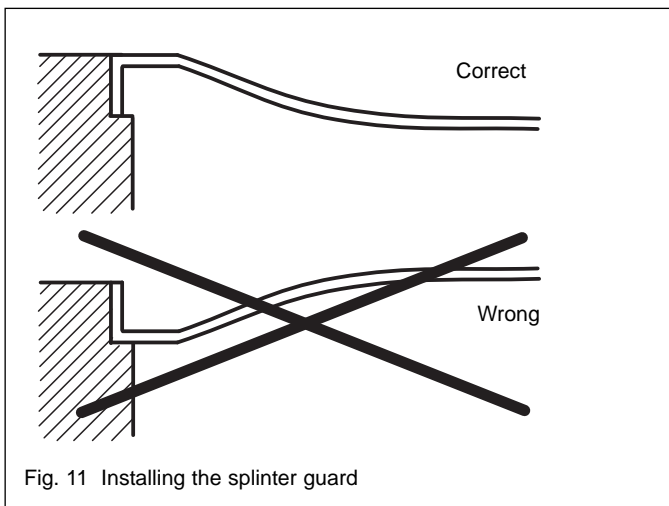

2.4 Connecting the MAG to the vacuum chamber

The MAG is shipped in a sealed PE bag with desiccant. Do not open the package until immediately before installing.

Do not remove the covers and blanking flanges until you are ready to make the connections, to ensure that the MAG is installed under the cleanest possible conditions.

Pay attention to maximum cleanliness when connecting.

Remove the transport seal from the intake flange. To do so unscrew the screws (10/2) and remove the aluminum cover. We recommend saving the transport seal for maintenance.

Foreign objects entering the pump through the high-vacuum flange can cause serious damage to the rotor. That's why the splinter guard must always be installed.

Damages caused during operation without the splinter guard are excluded from warranty.

Caution

Install the splinter guard as shown in Fig. 11. Installing the splinter guard upside down may lead to contact between splinter guard and rotor during fast venting of the pump.

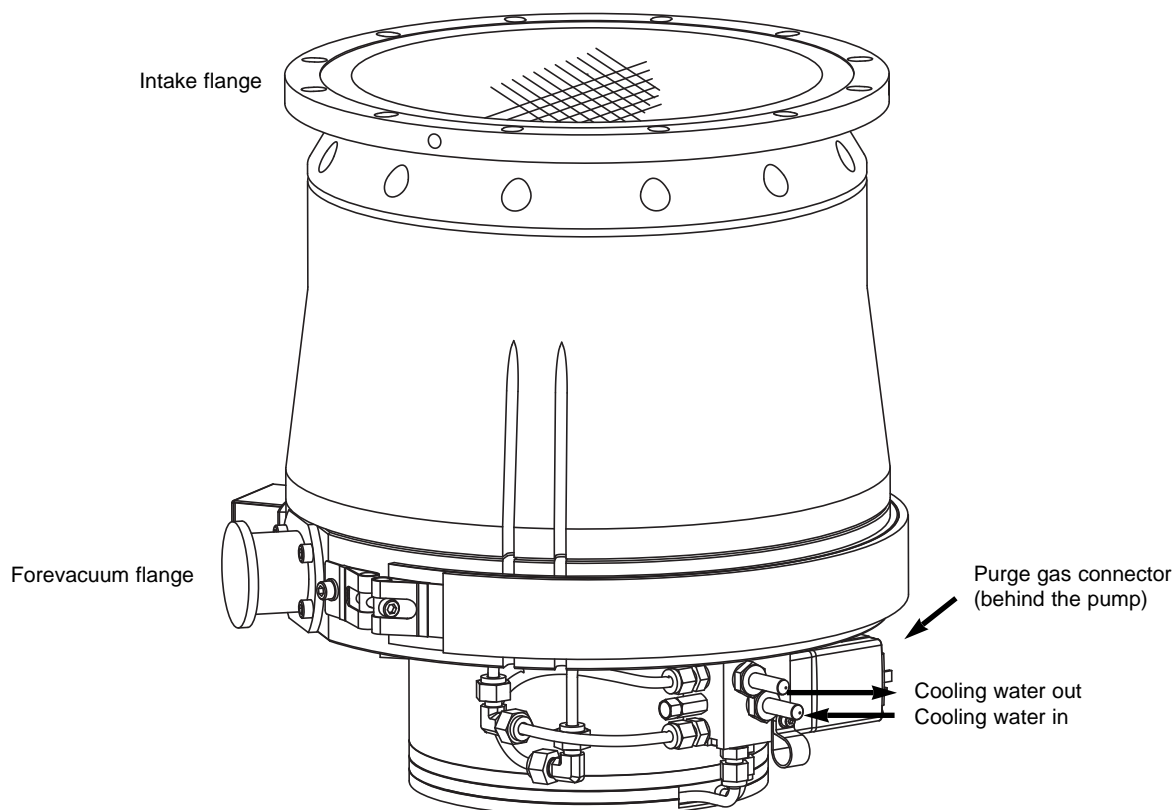

Fig. 12 Connection elements

Warning



The pump must be securely attached. If the pump should suddenly seize, inadequate attachment could cause the pump to break away or allow internal pump parts to be discharged. Never operate the pump (in bench tests, for instance) without its being connected at the vacuum chamber.

If the pump should suddenly seize, the deceleration torque of 60,000 Nm will have to be absorbed by the system. To accomplish this, use all 12 bolts provided by Leybold for fastening the high-vacuum flange; see also Fig. 15.

Mount the MAG as close as possible to the vacuum chamber. If the MAG is permanently flanged to a vacuum chamber with a weight exceeding 500 kg, it will not be necessary to secure it in any other way.

The vacuum chamber must be securely attached to the floor or a solid wall.

In case of lighter vacuum vessels secure the pump additionally. The pump's bottom is equipped with tapered holes for fastening a support; see Fig. 14.

If the pump is exposed to shocks, e.g. by a gate valve, secure the pump so that it is supported in the direction of the shock.

Earthquake protection

For earthquake protection fix the pump as shown in Fig. 13, 14 and 15. Depending on the chamber's weight and fixing use the boreholes in the pump's bottom in addition.

The standard fixing for the converter is shown in Fig. 6.

We recommend installing an isolation valve between the pump and the chamber. The valve should be closed during wet cleans of the chamber and in case of pump failures which will lead to a pump shut down. The valve should normally be closed with power off.

Warning



The pump can become so hot during operation ($> 85^{\circ}\text{C}$, $> 185^{\circ}\text{F}$) that it represents a burn hazard: Provide protection against contact with the hot components.

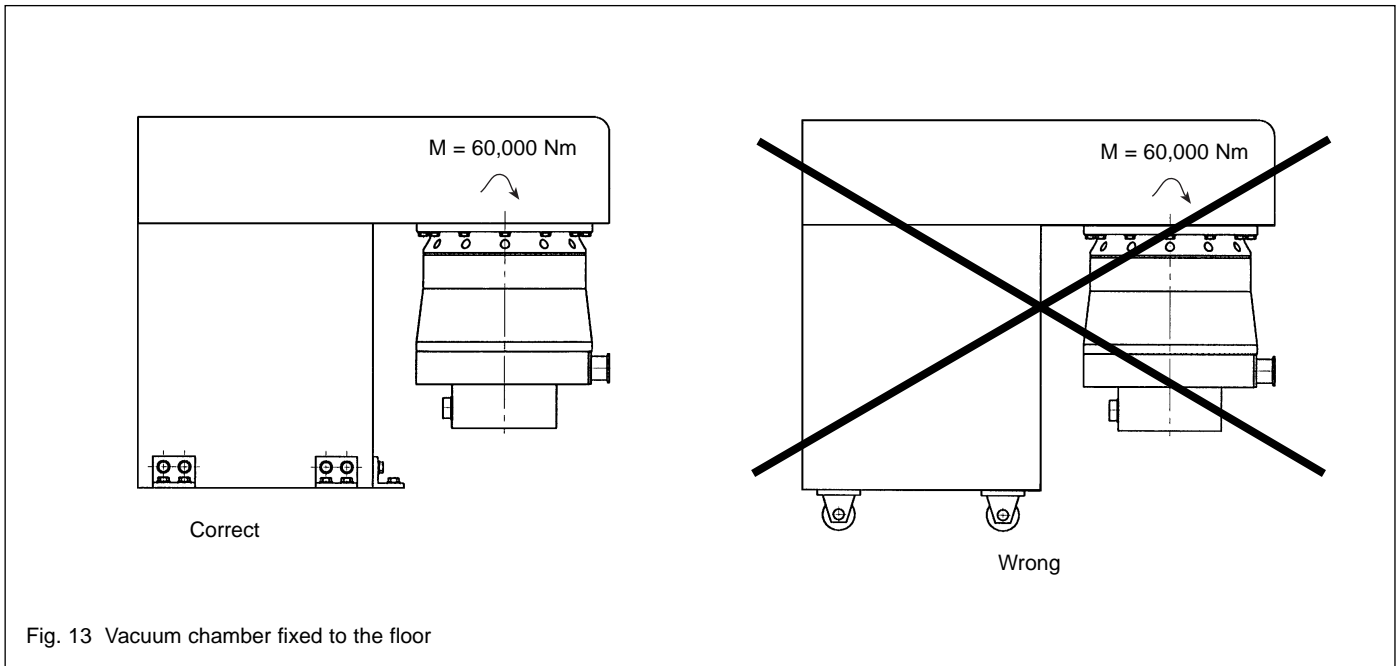

Fig. 13 Vacuum chamber fixed to the floor

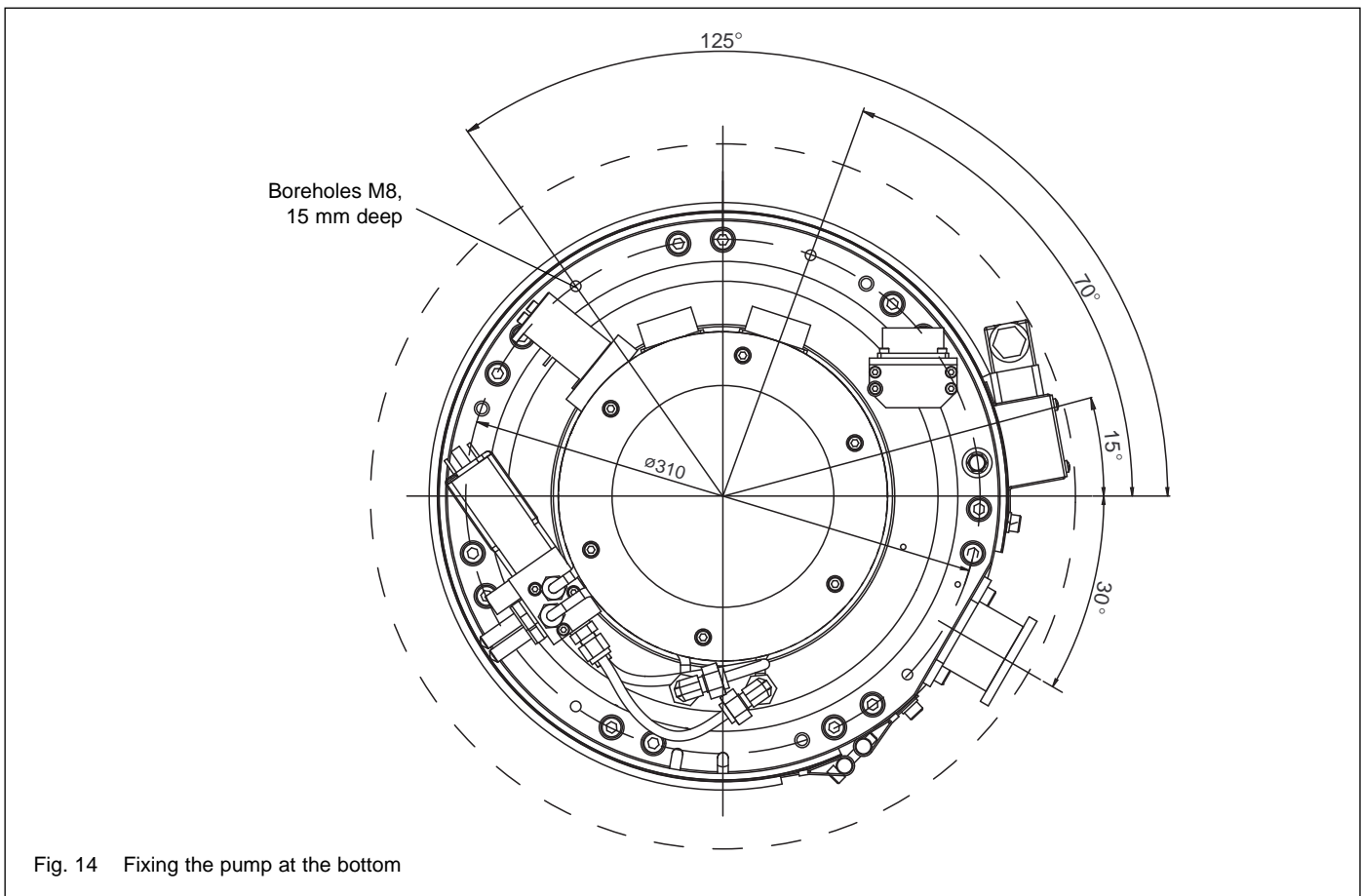

Fig. 14 Fixing the pump at the bottom

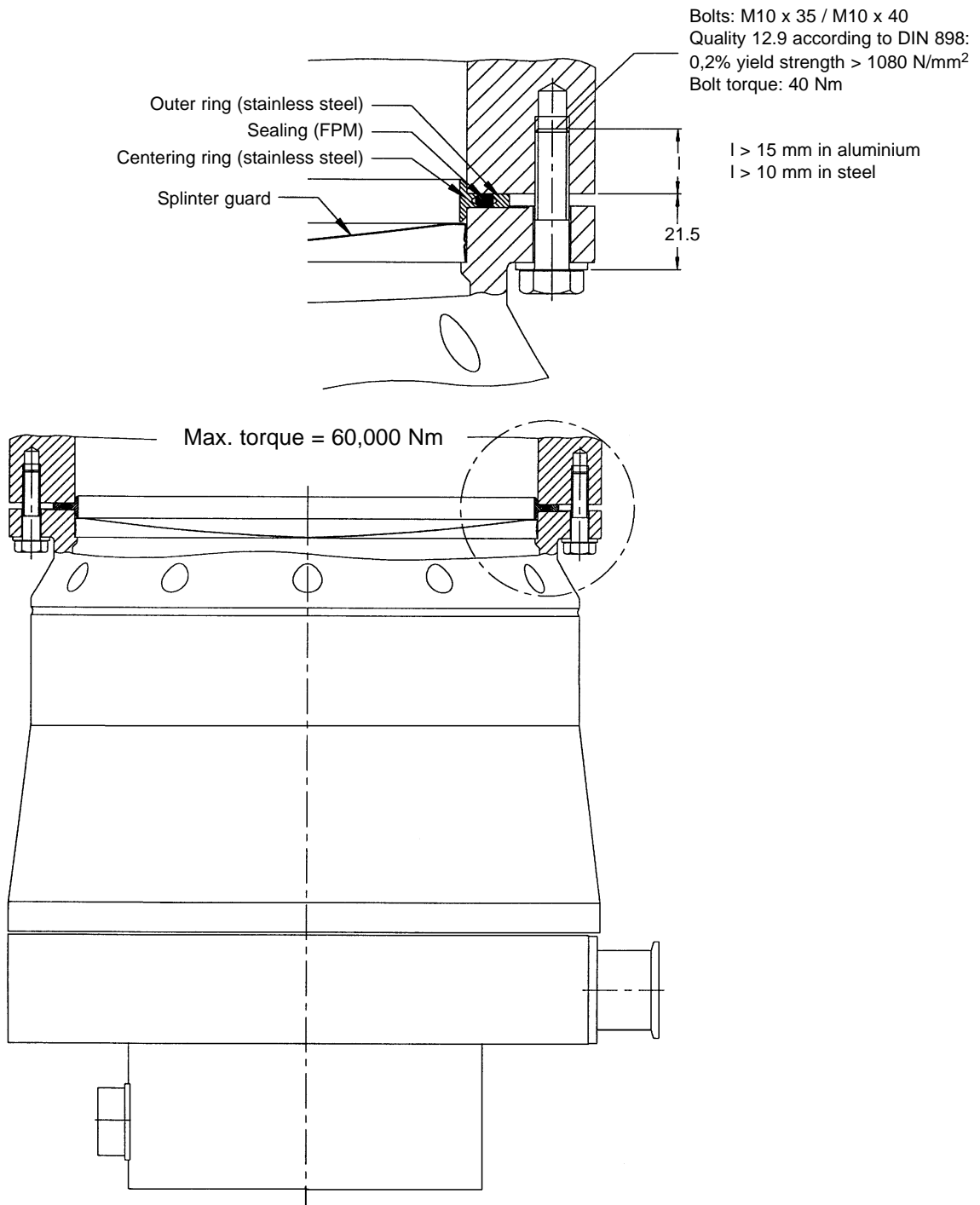

Fig. 15 Fixing the intake flange

$M < 150 \text{ Nm}$
 $M_q < 150 \text{ Nm}$

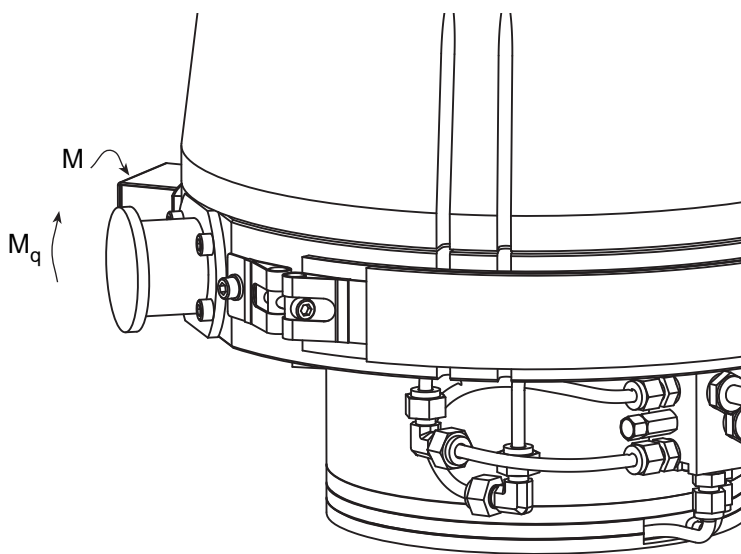

Fig. 17 Maximum torques for the forevacuum connection

2.5 Connecting the backing pump

A two stage rotary vane pump or dry-compression backing pump is required to support operation of the MAG.

We recommend using our DRYVAC or TRIVAC pump for this purpose.

In case of high gas throughput, it may also be necessary to use a roots blower to achieve the backing pressure necessary for operating the MAG. We recommend our RUVAC blower for this purpose or our DRYVAC 251/501 systems.

Fig. 16 shows schematically the design of a pump system incorporating a MAG with an additional foreline valve and an isolation valve between chamber and MAG.

The foreline isolation valve is recommended to protect the MAG from shock venting in case of uncontrolled shut down of the backing pump. This valve must be able to close fast enough to avoid pressure increase in the MAG.

In case of an oil-sealed backing pump the foreline isolation valve protects the MAG from backstreaming oil vapor during standstill.

Connect the forevacuum flange of the MAG to the backing pump.

The torque on the forevacuum connection flange must not exceed the values shown in Fig. 17.

Warning



The forevacuum line must be tight. Hazardous gases can escape at leaks or the gases being pumped can react with the air or humidity. We recommend a leak check.

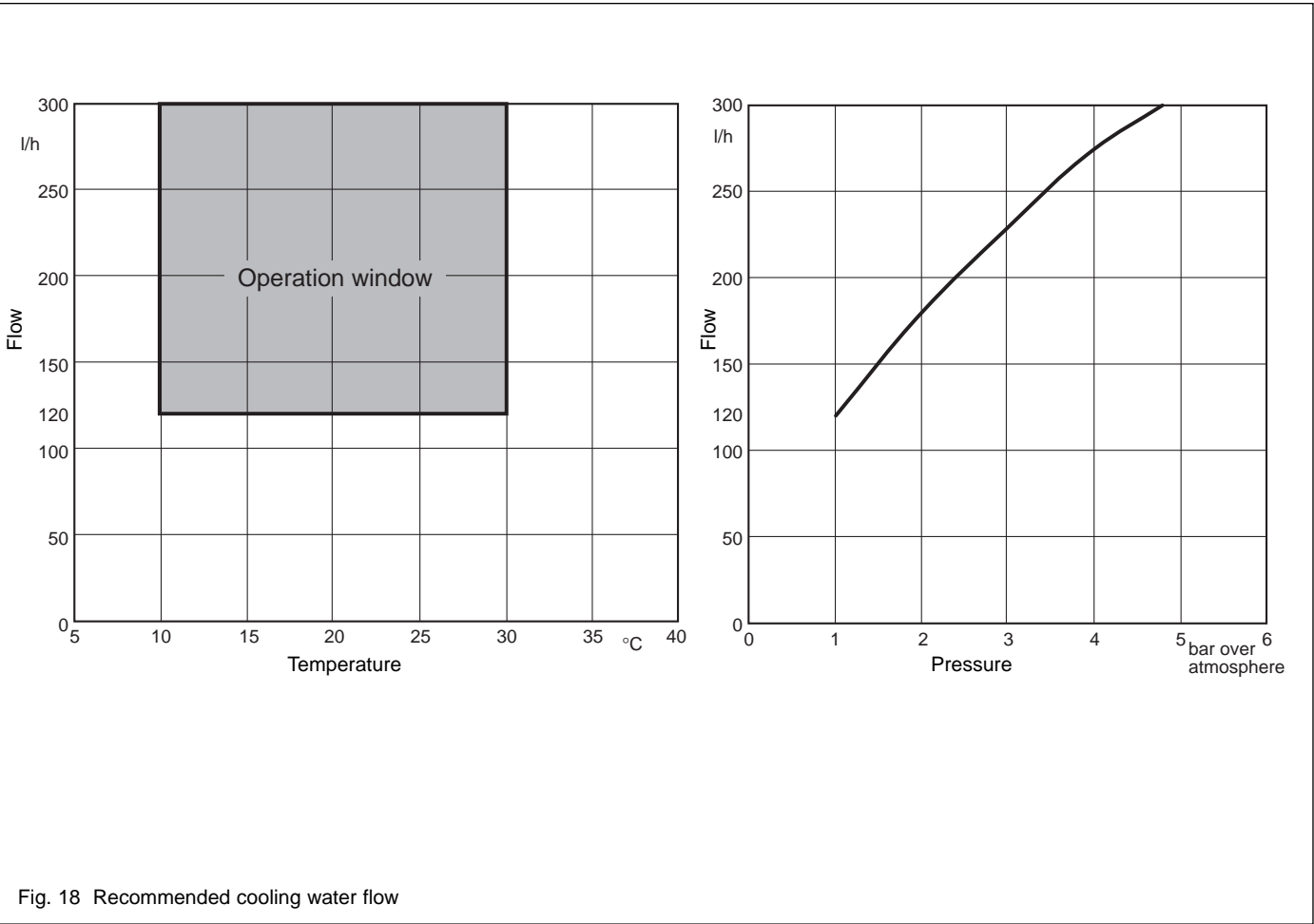

Fig. 18 Recommended cooling water flow

2.6 Connecting the cooling water

Cooling water specifications

Inlet temperature	10 - 30 °C
Inlet pressure	2 to 6 bar absolute i.e. 1 to 5 bar over atmosphere
Cooling water requirement	See Fig. 18
Appearance	Colorless, clear, free of oils and greases
Sediments	< 250 mg/l
Particle size	< 150 µm
Electrical conductivity	< 500 µS/cm
pH value	7 to 8.5
Overall hardness (total alkaline earths)	max. 20 ° German hardness scale (= 3.57 mmol/l)

Further information on request.

Connect the cooling water to the connectors; see Fig. 19.

Caution

Make sure that you do not mix up the inlet and the outlet connection. If it is mixed up the water valve will not work correctly.

Turn off the cooling water supply when the pump is switched off in order to avoid condensate formation in the pump.

If you do not close the cooling water it may take longer to achieve ultimate pressure after start up of the system.

An internal bypass in the cooling water distributor allows operating the MAG in series with other cooling water consumers.

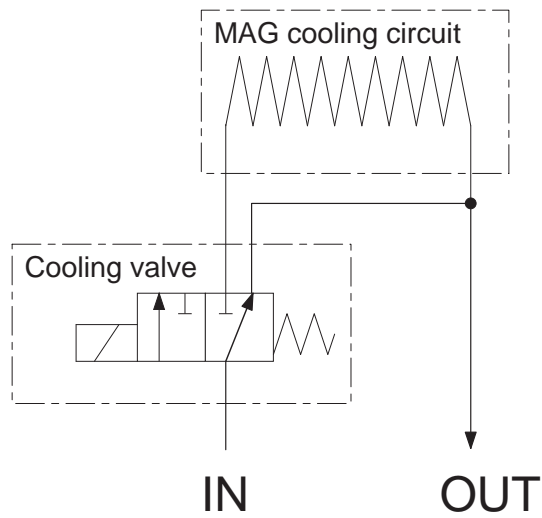
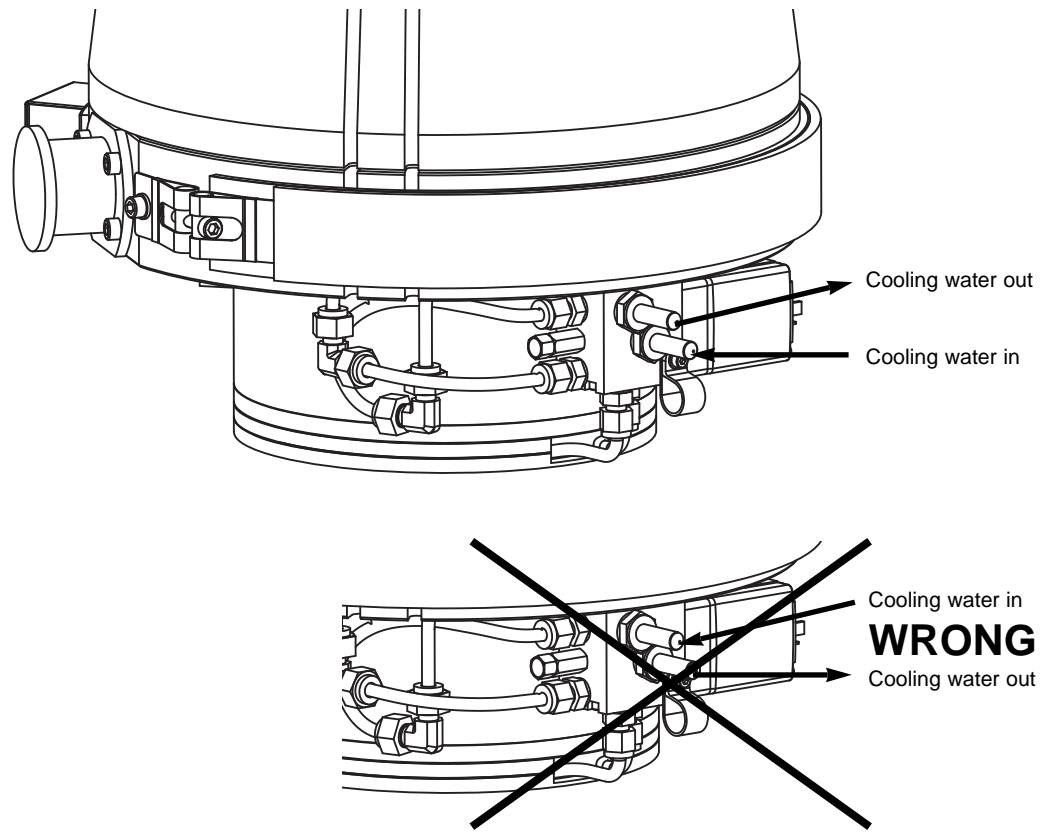

Fig. 19 Connecting the cooling water

2.7 Connecting the purge gas

The MAG is equipped with a purge gas connector. To ensure protection of the pump a constant purge gas throughput of 30 to 40 sccm is required. You may use a flow controller to ensure the flow. Inadequate purge gas flow voids the warranty.

Connect purge gas to the VCR nut 1/4" as shown in Fig. 20.

Warning



Monitor the purge gas continuously.

Insufficient purge gas flow can result in:

- Process gases entering the motor and bearing area of the MAG
- Process gases escaping from the purge gas connector
- Humidity entering the pump.



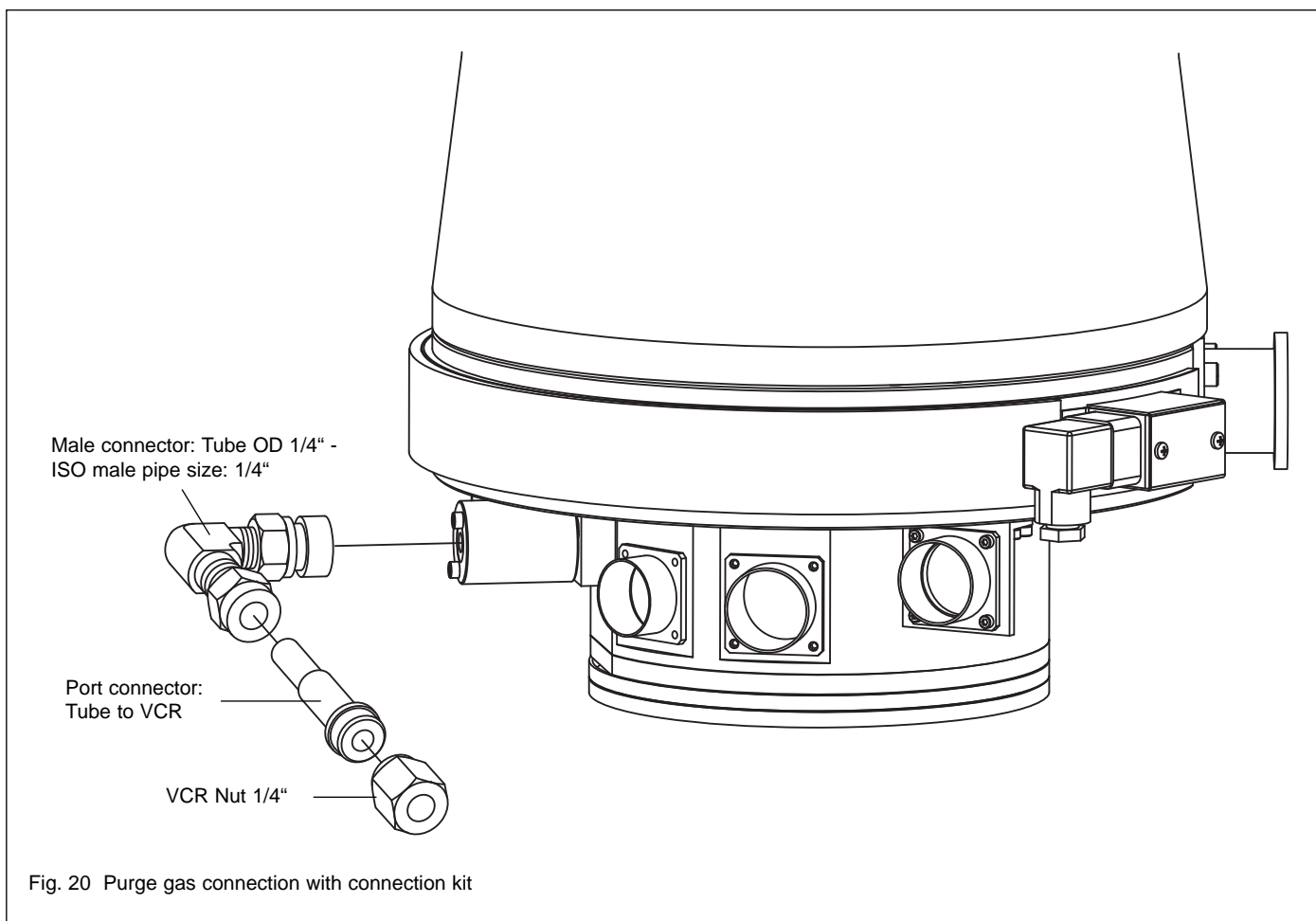

2.8 Installing the MAG.DRIVE

The converter can be installed in a 19" cabinet. It is 1/2 of 19" wide and has 3 height units. For easier installation we offer an installation frame; see Section 1.7. If you use this installation frame, remove the converter's rubber feet when installing the converter.

Caution

In order to guarantee sufficient cooling, there must be a minimum clearance of 1 height unit (44.2 mm) at the bottom and 1 height unit at the top. During operation the temperature of the ambient air must not exceed 45 °C.

Warning



The pump may be operated only with a suitable frequency converter and a suitable connector cable.

The MAG W 2010 CHT can only be operated with the MAG.DRIVE 2000 converter and **not** with the MAG.DRIVE L or L2.

Peak voltages of up to 130 V may be present at the connector line between the frequency converter and the pump; mains voltage is present at the heater.

Route all cables so as to protect them from damage.

The protection rating for the connectors is IP 30.

Do not expose the pump, the frequency converter or the connections to dripping water.

Install 16 A fuses for the converter.

When connecting the frequency converter to a polyphase network between two phases, provide additional external fuse protection for **both** phases (fuse amperage: 16 A).

Warning



Only adequately trained electrical/electronic personnel may connect-up the equipment in accordance with valid IEC (international), EN (European) and/or national guidelines, or under their management and supervision.

Warning



The connecting cables between the converter and pump may only be inserted or removed when the pump is switched off **and** stands still after the run-down procedure **and** the converter is isolated from the line supply.

To avoid contact with hazardous voltages, the safety sleeves **must** be mounted properly on

- the DRIVE/TMS connector at the converter (see Fig. 21) and
- the TMS connector on the pump.

Do not switch on frequency converter **until all cables** have been connected properly.

Warning



Unauthorized opening of the converter voids the warranty.

Hazardous voltages are present inside the converter. Death or severe injury can occur if you come into contact with these hazardous voltages. Before opening the converter, isolate the converter from the line supply, and lock the switch so that it cannot be accidentally switched on again.

In addition the pump has to stand still because it works as generator as long as it rotates, and the pump cables have to be disconnected.

Installation instructions to maintain EMC

The MAG.DRIVE 2000 complies with the Electromagnetic Compatibility (EMC) Directives of the EC. In order to maintain this the following installation instructions must be observed:

- To connect the pump to the converter the prescribed Leybold cables must be used.
- The connection cables to the analog interface (control plug X14) and to the serial interface (connector X7) must be shielded. The shields must be connected to the metal housings of the SUB-D-connector and SUB-D-socket.

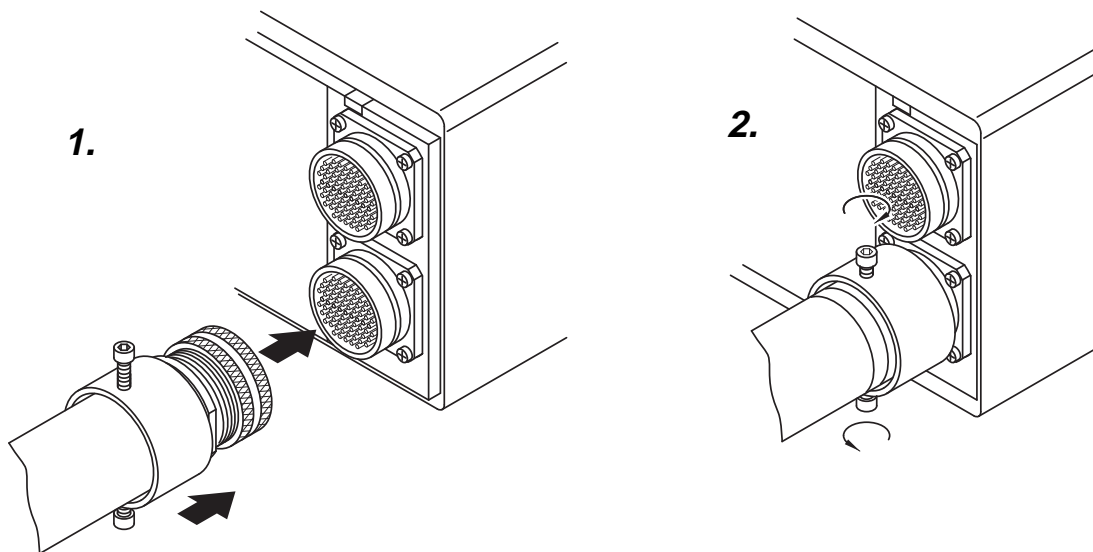
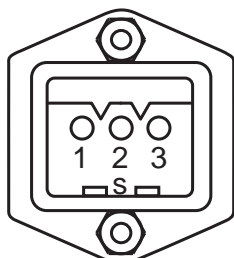

Fig. 21 Mounting the safety sleeves; rear side of the converter shown.
Mount the safety sleeve onto the pump's TMS connection too.



- 1 = Phase L
- 2 = Not assigned
- 3 = Neutral N
- S = PE

Fig. 22 Connector assignment X19, supply connection

2.8.1 Power supply connection X19

The converter is ready to be connected to line supply voltages between 200-240 V 50/60 Hz. The connection is established using the power cable supplied, which is inserted at connector X19 at the rear of the converter.

Caution

The converter will be damaged if it is operated with the incorrect supply voltage.

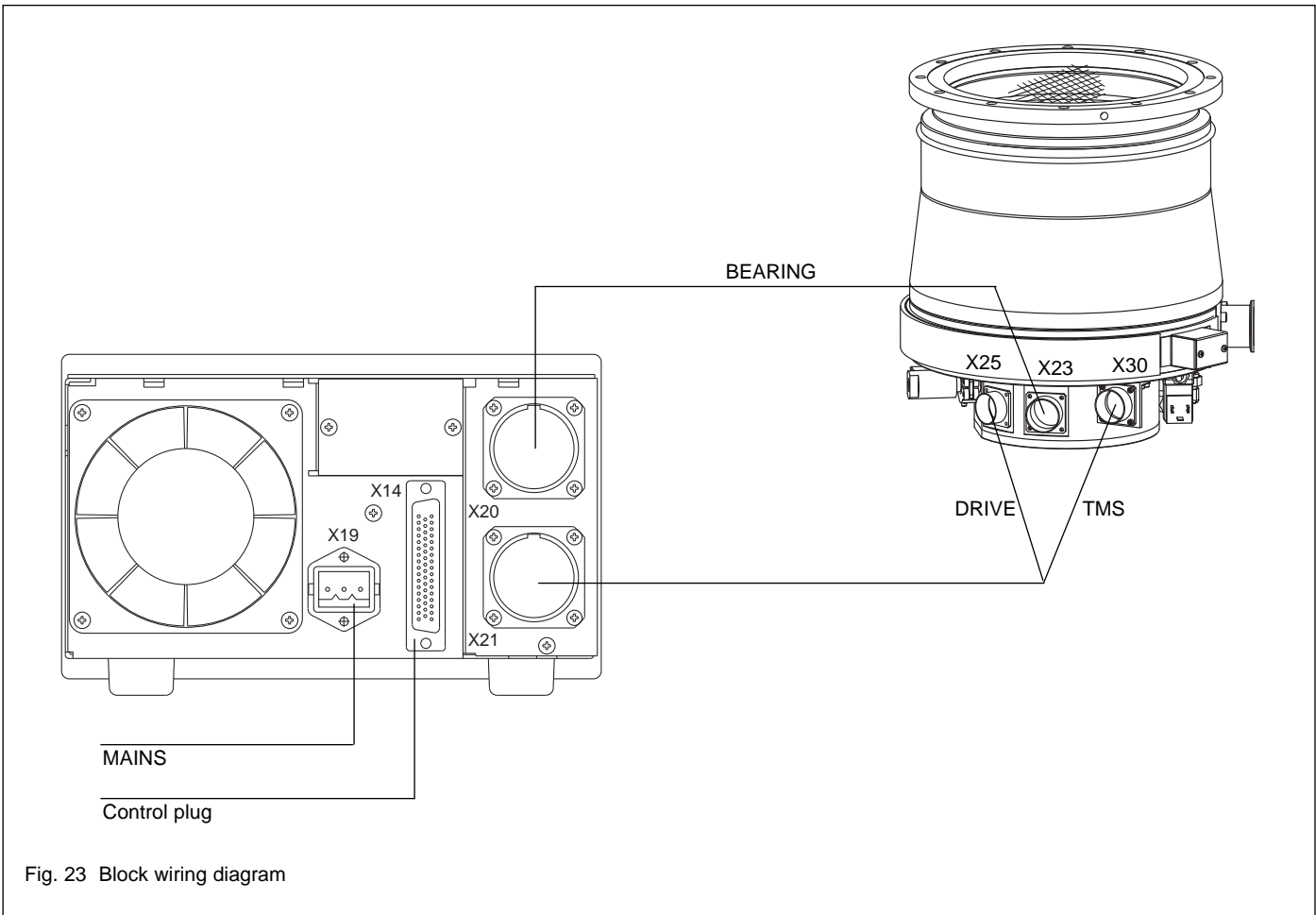

Fig. 23 Block wiring diagram

2.8.2 Pump connection

Warning



To avoid contact with hazardous voltages in case of malfunction the pump must be connected to PE, see Fig. 24.

Connect the converter (X20) to the magnetic bearing connection of the pump (X23) using the BEARING cable.

Connect the converter (X21) to the pump motor connection (X25) and to the TMS connection (X30) using the combined DRIVE/TMS cable.

Also refer to Fig. 21 and 23.

Make sure that you have fixed all cables properly. Push the safety sleeves onto the the DRIVE/TMS connector at the converter and the TMS connector on the pump and tighten the screws.

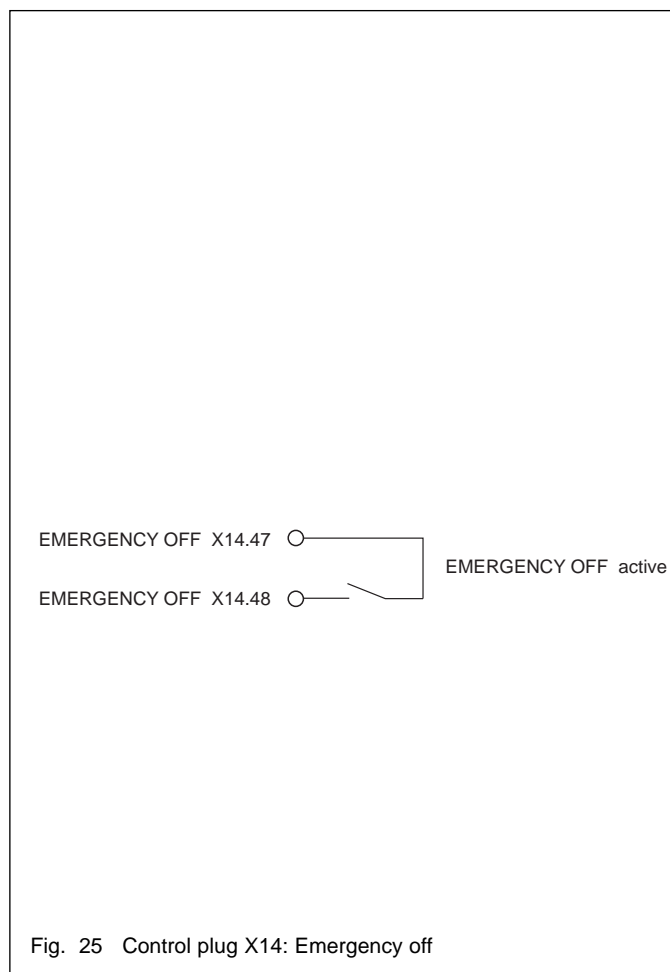
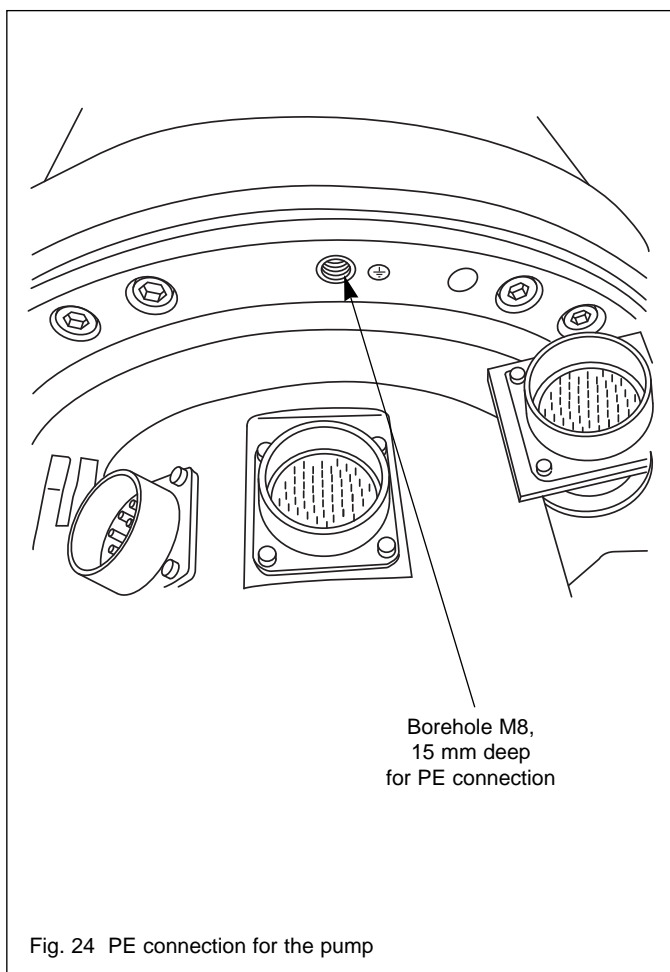

2.8.3 Control plug X14

Emergency off

Make sure that pins 47 and 48 are connected via a jumper if you don't connect an emergency off switch.

A plug for the control plug X14 with a jumper connected between pins 47 and 48 is included in the standard specification.

Description of the Emergency Off connection

Pins 47 and 48 of control plug X14 make it possible to disable the output stage of the frequency converter via the hardware. The power flow to the motor is then interrupted.

The two pins must be connected to each other to ensure proper operation.

If the two pins are to be monitored by the system control, a floating (dry) contact must be available on the system side; load carrying capacity: 42 VDC, 100 mA.

The contact used and the connecting cable **must** be protected against line supply voltage through double or reinforced insulation such that no hazardous contact line supply voltage can be applied to pins 47 and 48 in the event of a fault.

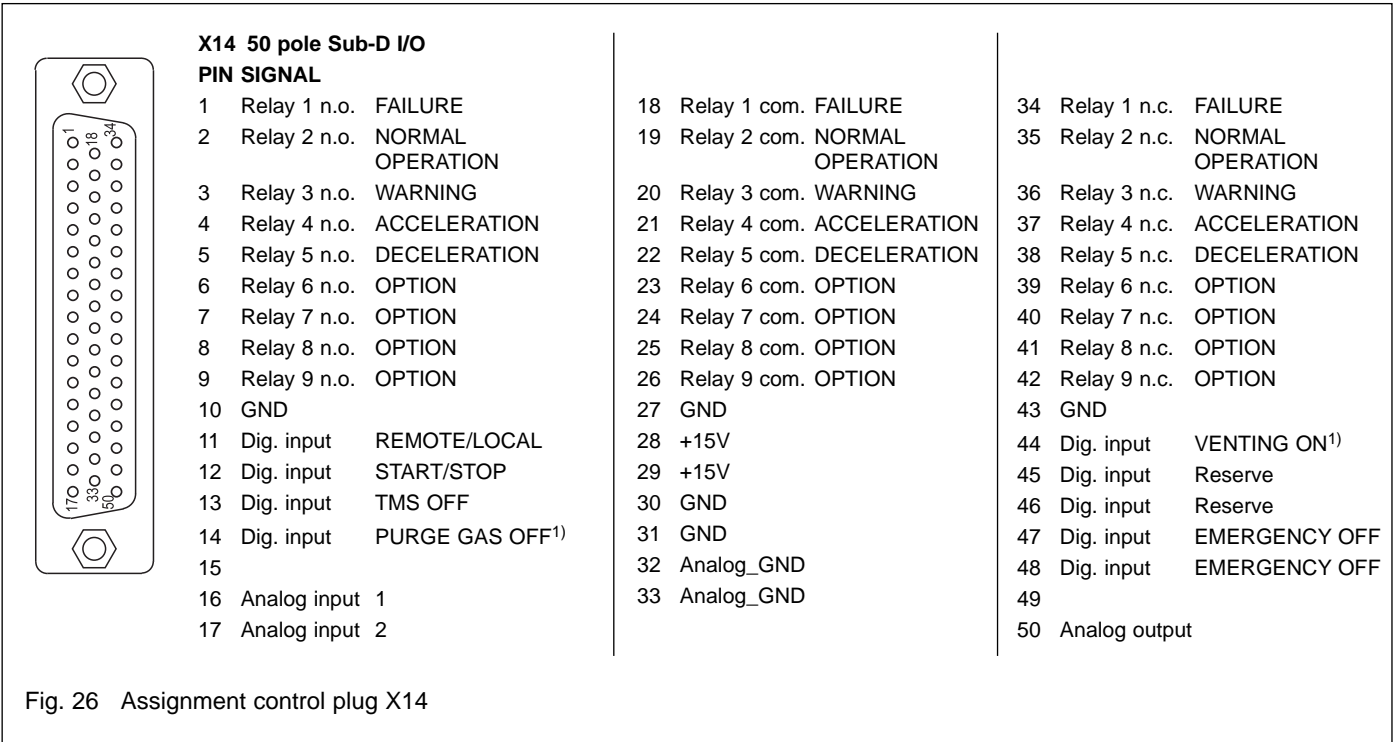

Fig. 26 Assignment control plug X14

Relay outputs

The MAG.DRIVE 2000 converter has 9 relay outputs. They have changeover contact. Five relay outputs are permanently assigned a signal.

- Failure
- Normal operation
- Warning
- Acceleration
- Deceleration

The option relays can output one of the following signals:

- Threshold bearing temperature reached
- Threshold motor current reached
- Threshold frequency reached
- No cooling water
- No purge gas¹⁾
- TMS temperature OK
- Vent¹⁾
- Start command applied
- Power supply O.K.
- Pump standstill

Option relay 6 can store the selected signal. The option relays 7, 8, and 9 cannot store the selected signal permanently and change to the default setting after a power interruption. We recommend using only the default settings for the option relays 7, 8, and 9.

- Option relay 7 Start command applied
- Option relay 8 Power supply O.K.
- Option relay 9 Pump standstill

The selection of signals for the option relay and the adjustment of their thresholds can be achieved via the operator control menu; see Section 4.3.2.

Analog output

The converter has an analog output which provides an analog signal (0..10 V) with a 10-bit resolution. The analog output function can be alternatively used to output

- motor current
- actual frequency
- motor temperature
- rotor displacement signals (PW24, PV13, PZ12)

The output value can be increased or reduced by a scale factor; see Section 4.3.2 Settings Converter.

1) not active at MAG W 2010 CHT

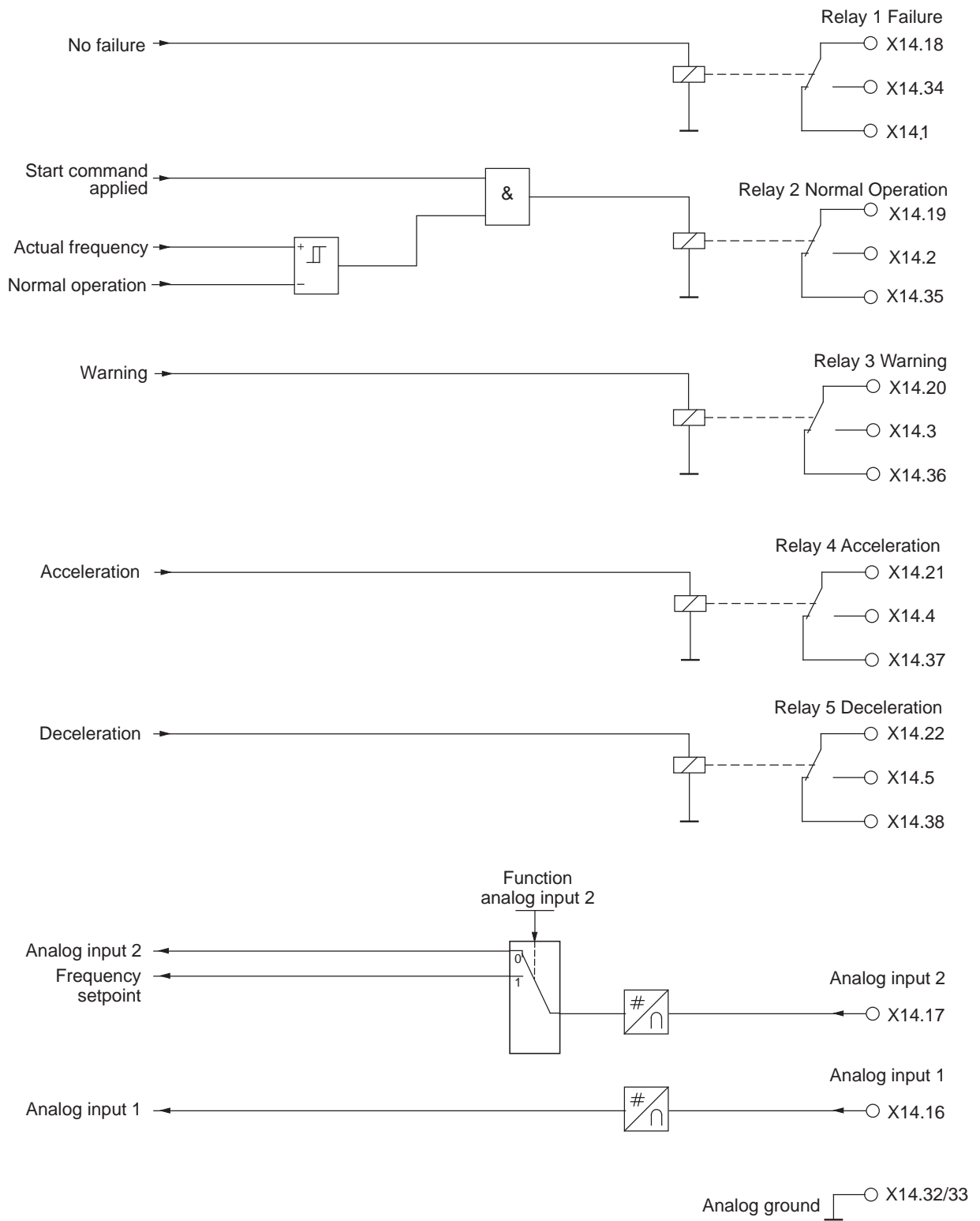

Fig. 27 Function diagram outputs, Part 1 & inputs

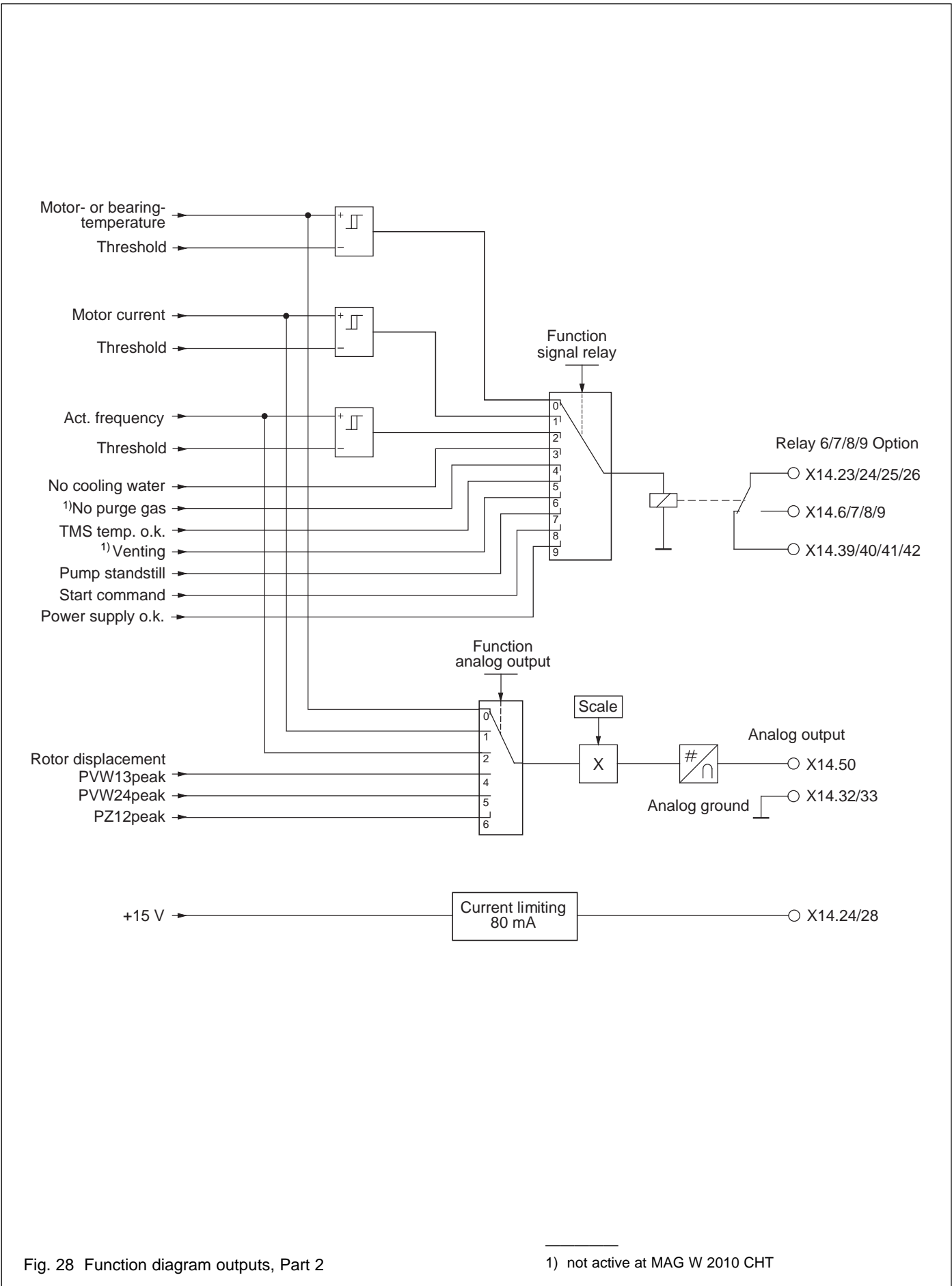
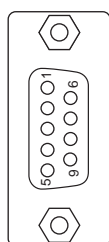

Fig. 28 Function diagram outputs, Part 2

1) not active at MAG W 2010 CHT



- 1 +5V Power supply for plug-in control
- 2 TXD
- 3 RXD
- 4 n.c.
- 5 GND
- 6 -5V Power supply for plug-in control
- 7 Reset out for plug-in control
- 8 select plug-in control input
- 9 Boot input

Fig. 29 Connector assignment, interface X7
(front side)

Analog inputs

The converter has two analog inputs with a 10-bit resolution.

Input signal: 0...10V

A supplementary function can be set for analog input 2 via the operator control menu; see Section 4.3.2:

No function: The input signal can be output via the serial interface.

Frequency setpoint: In addition to the function described above, the drive frequency setpoint is entered via analog input 2.

Digital inputs

The converter has 5 digital inputs with the following functions:

TMS OFF

Purge gas OFF¹⁾

Vent ON¹⁾

The functions are active if a High signal (15 V; e.g. Pins 28 or 29) is connected at the digital input.

Remote

Start (if Remote is active)

The functions Start and Remote are active if a Low signal (GND; e.g. Pins 27 or 43) is connected at the digital input.

1) not active at MAG W 2010 CHT

2.8.4 Interface connector

A 9-pin sub-D socket is provided at the front panel. The connector X7 is assigned the serial interface RS 232. It is only to be used by the Leybold Service.

3 Operation

3.1 General operation rules

The magnetic bearing in the MAG are immune to wear. In addition to the magnetic bearings, the MAG is equipped with touch-down bearings which protect the rotor against mechanical contact with the stator if the pump is subjected to external shock loading or when the pump is switched off. These touch-down bearings have a limited service life. Please observe the following in order to obtain maximum service life.

- Avoid shock and vibrations when the pump is running. Shocks perpendicular to the rotation axis are particularly harmful. If the pump appears to be running in the mechanical bearings continuously it is switched off.
- Do not suddenly expose the MAG to an already evacuated vacuum chamber. The pressure surge may cause the rotor to make contact with the touch-down bearings. This will cause increased wear.
- Do not disconnect the MAG and MAG.DRIVE while they are operating. If MAG and MAG.DRIVE have been disconnected accidentally re-connect them.
- When venting the MAG the values shown in the pressure rise curve must be maintained; see Fig. 30.
- Do not stop the MAG with the mains. Use the STOP key or a stop command. Switching off the mains while the pump is running will wear out the touch down bearings.

The pump may make noise during the run-up and run-down phases. This has neither an influence on the pump nor on the process.

Warning



Monitor the purge gas continuously. Insufficient purge gas flow can result in:

- Process gases entering the motor and bearing area of the MAG
- Process gases escaping from the purge gas valve
- Humidity entering the pump.



Refer to Section 2.7.



Warning



The pump will be hot during operation. Burn hazard!

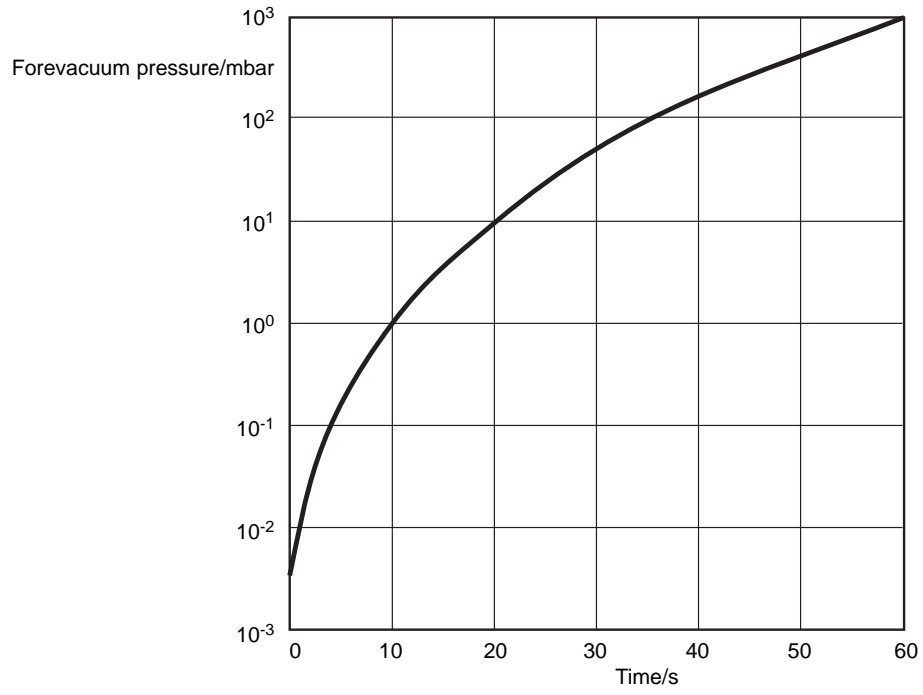

Fig. 30 Curve for safe venting of the MAG; pressure rise as a function of venting time

3.2 Operation with the START and STOP keys

Switching on

- Switch on the MAG.DRIVE.

The MAIN LED lights green.

If the pump has the optional TMS (including e.g. the red heater band) the heater will be activated. The setpoint temperature will be reached within 30 - 60 minutes depending on cooling water temperature and flow.

In case of corresponding connection the backing pump will be activated when switching on the MAG.DRIVE.

- Open the purge gas supply. With a converter with default settings the pump's purge gas valve is open.
- Open the cooling water supply.
- Press the START key.

The pump runs-up. The STATUS LED is slowly flashing green. When the STATUS LED is lit permanently green the pump is in normal operation.

The backing pump and the MAG can be switched on simultaneously. In such a situation the MAG serves from the very outset as an effective baffle.

Switching off

- Press the STOP key.

The STATUS LED is fast flashing green. When the STATUS LED is off the pump has come to a standstill.

- Close the cooling water supply when the pump is switched off in order to avoid condensate formation in the pump.

The backing pump may be switched off once the MAG has stopped.

If the MAG has been used for pumping corrosive gases it should be purged with dry nitrogen for one hour before switching off. During down times of the system take care that neither ambient air nor cleaning agents enter the pump.

After a failure has occurred and has been removed, acknowledge the failure message by pressing the STOP key.

Significance of the lamps



COM (green)

Is lit if communication has been established via the interface.

STATUS (green/red)

Red, steady light	= Failure
Red, flashing	= Warning
Green, flashing (slow)	= Start delay, Acceleration
Green, flashing (fast)	= Deceleration, Kinetic buffering
Green, steady light	= Normal operation

MAIN (green)

This lamp is lit if the power is switched-on, and all of the supply voltages for operation are available.

Flashes when the power fails as long as the power supply voltages in the converter are maintained by the kinetic buffering.

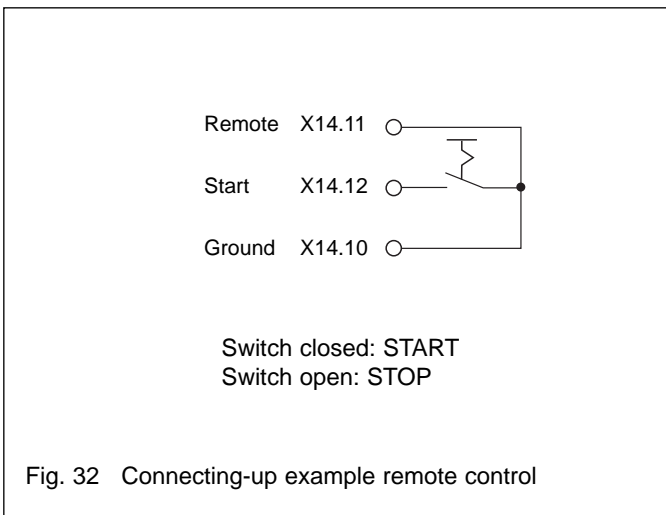
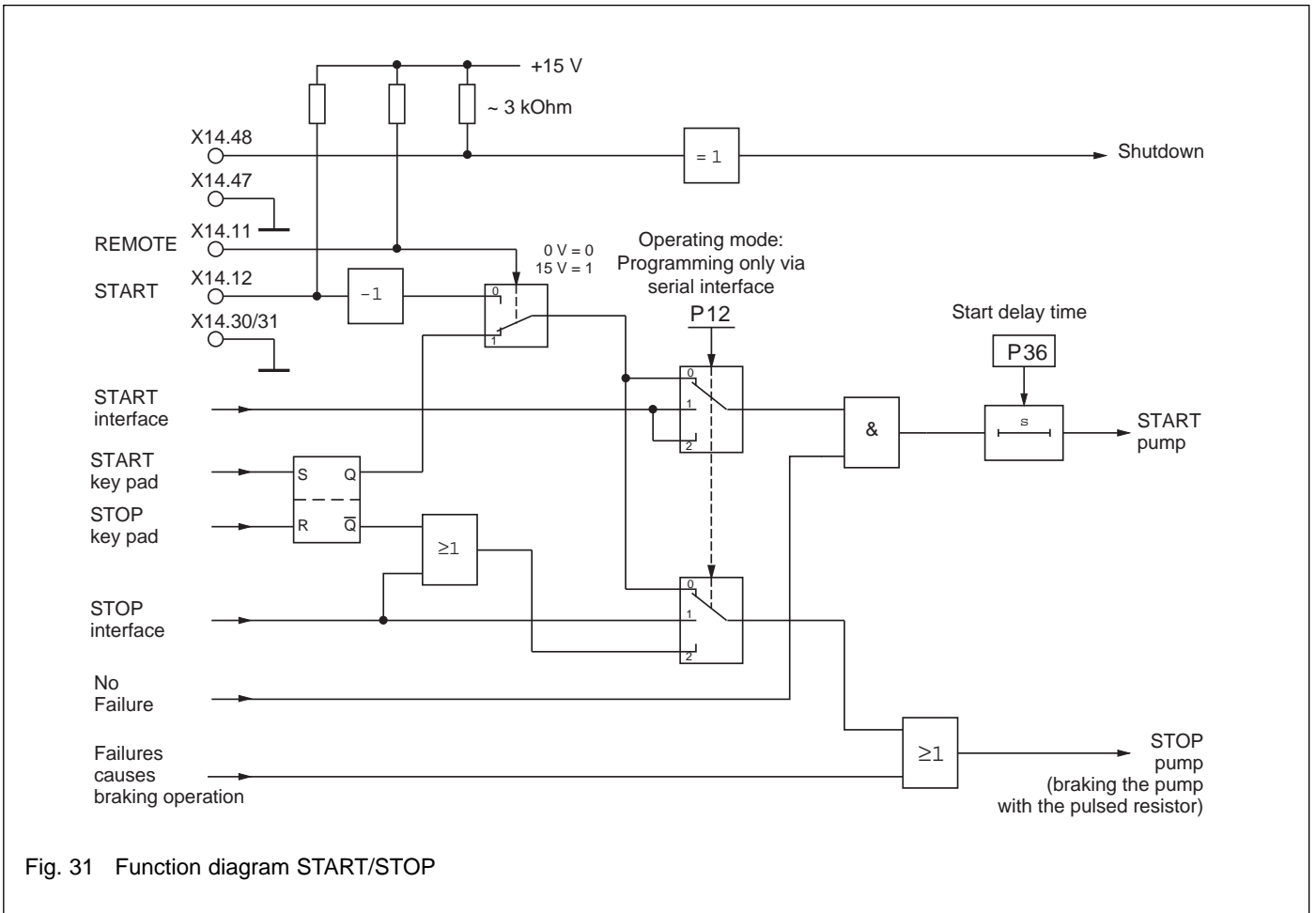

3.3 Remote control

The pump can be switched-on or off using the START/STOP keys or via control connector X14.

- X14.11 not connected = Start/Stop via the operator control panel
- Jumper X14.11-X14.10 = Start/Stop via control input X14.12

4 Plug-in control

4.1 Operation with plug-in control

Observe the general operation rules given in Section 3.1

Switching on

- Switch on the MAG.DRIVE. The display reads

Ready		
0.0 A		0 Hz

If the pump has the optional TMS (including e.g. the red heater band) the heater will be activated. The setpoint temperature will be reached within 30 - 60 minutes depending on cooling water temperature and flow.

In case of corresponding connection the backing pump will be activated when switching on the MAG.DRIVE.

- Open the purge gas supply.
- Open the cooling water supply.
- Press the START key.

The pump runs-up.

Acceleration		
20.0 A		250 Hz

is displayed until the frequency setpoint has been reached. Then

Normal Operation		
1.0 A		480 Hz

is displayed.

The backing pump and the MAG can be switched on simultaneously. In such a situation the MAG serves from the very outset as an effective baffle.

Switching off

The MAG.DRIVE controls the venting automatically provided purge gas is connected to the MAG and the MAG.DRIVE is programmed correspondingly („Vent on“).

- Press the STOP key.

Deceleration		
20.0 A		400 Hz

will be displayed. When the display reads

Ready		
0.0 A		0 Hz

the pump has come to a standstill.

- Close the cooling water supply when the pump is switched off in order to avoid condensate formation in the pump.

The backing pump may be switched off once the MAG has stopped.

If the MAG has been used for pumping corrosive gases it should be purged with dry nitrogen for one hour before switching off. During down times of the system take care that neither ambient air nor cleaning agents enter the pump.

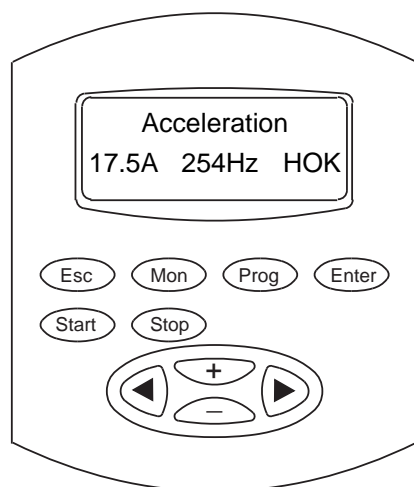

Key	Function
Esc	<ul style="list-style-type: none"> Returns to the operating display from the storage procedure without storage. Returns to the operating display from any point of the basic menu.
Mon	<ul style="list-style-type: none"> No function
Prog	<ul style="list-style-type: none"> Selects the programming menu from the operating display. Confirms to store changed parameters to the EEPROM
Enter	<ul style="list-style-type: none"> Switches forward to the next submenu
Start	<ul style="list-style-type: none"> Starts the pump (only possible if there is no fault). The start key is only active if the user is in the basic menu or in the operating display.
Stop	<ul style="list-style-type: none"> Stops the pump Returns to the operating display from the programming menu. Acknowledges a failure after the cause of the failure has been removed.
+	<ul style="list-style-type: none"> Increases a parameter value or proceeds to the next option.
-	<ul style="list-style-type: none"> Lowers a parameter value or returns to the previous option.
◀	<ul style="list-style-type: none"> Selects the programming menu from the operating display. Switches back to the last main menu.
▶	<ul style="list-style-type: none"> Selects the programming menu from the operating display. Switches forward to the next main menu.

Fig. 33 Functions of the front panel keys

Operating display

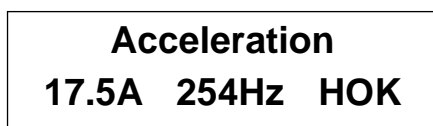

Operating status

Motor current / Actual frequency / TMS status code

If a critical operating status occurs this warning is displayed alternating with the operating display.

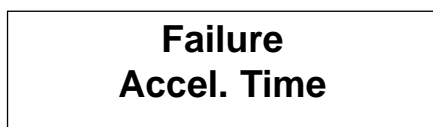

Failure message

Failure cause

TMS status code

No.	Code	Description
1	H	Heating pump
2	H O K	Temp. TMS ok, heater ON
3	O K	Temp. TMS ok (range $T_{set} \pm 2K$)
4	C O K	Temp. TMS ok, cooling ON
5	W	Warning Temp. TMS
	O F F	TMS cancelled via control plug X14

see also Section 4.4 „TMS“

Fig. 34 Display

4.2 Operating statuses

Switch-On Guard

The converter goes into the "Switch On Guard" operating status after the power is switched on and after initialization. If there is no warning or failure, it changes over into the "Ready" condition.

After a failure has been acknowledged, the converter goes into the "Switch On Guard" operating status. The failure must be acknowledged a second time, so that it then goes into the "Ready" condition.

Ready

The converter is ready and waits for the START command. All parameters can be interrogated or changed via the operator control panel or the serial interface.

The basic menu parameters (refer to 4.3, operating menu) can be scanned via the operator control panel.

Acceleration

The pump continuously accelerates with the maximum current. The acceleration time is monitored to ensure that it lies within a programmed value (refer to the menu "settings pump/Accel. Time"). If the converter hasn't reached the normal operating mode during the monitoring time, then it is shutdown with the failure message „Accel. Time“.

Normal operation

After a programmable frequency threshold has been reached (refer to the menu "settings pump/Normal Operation"), the converter goes into the normal operation mode but the pump continues to accelerate up to the frequency setpoint.

Overload

The speed is continuously monitored and controlled. If the speed, even at maximum current, cannot be held at the setpoint, as a result of external influences, e.g. excessive gas intake, the speed reduces until the converter goes into the „Overload“ operating condition when the programmable frequency threshold is fallen below (refer to the menu "settings pump/Normal Operation"). The acceleration time is restarted. If the converter hasn't gone into the normal operating mode after the monitoring time, it is shutdown with the failure message „Failure Overload Time“.

Mains Down

If the power fails when the converter is switched on, the converter regenerates due to the pump up to a minimum frequency of < 170 Hz. When the power returns, the pump is again accelerated up to the frequency setpoint.

The acceleration time is now restarted. If the converter hasn't gone into the normal operating mode after the monitoring time, it is shutdown with the failure message „Accel. Time“ .

Deceleration

After a stop command, the pump is braked down to a speed < 1 Hz as quickly as possible. A brake resistor is integrated into the converter which converts the regenerative energy into heat.

Failure

The converter was shutdown with a failure message and waits for a failure acknowledgement after the failure has been removed. The failure type can be read from the display. The failure message can be acknowledged by depressing the STOP key or via the serial interface.

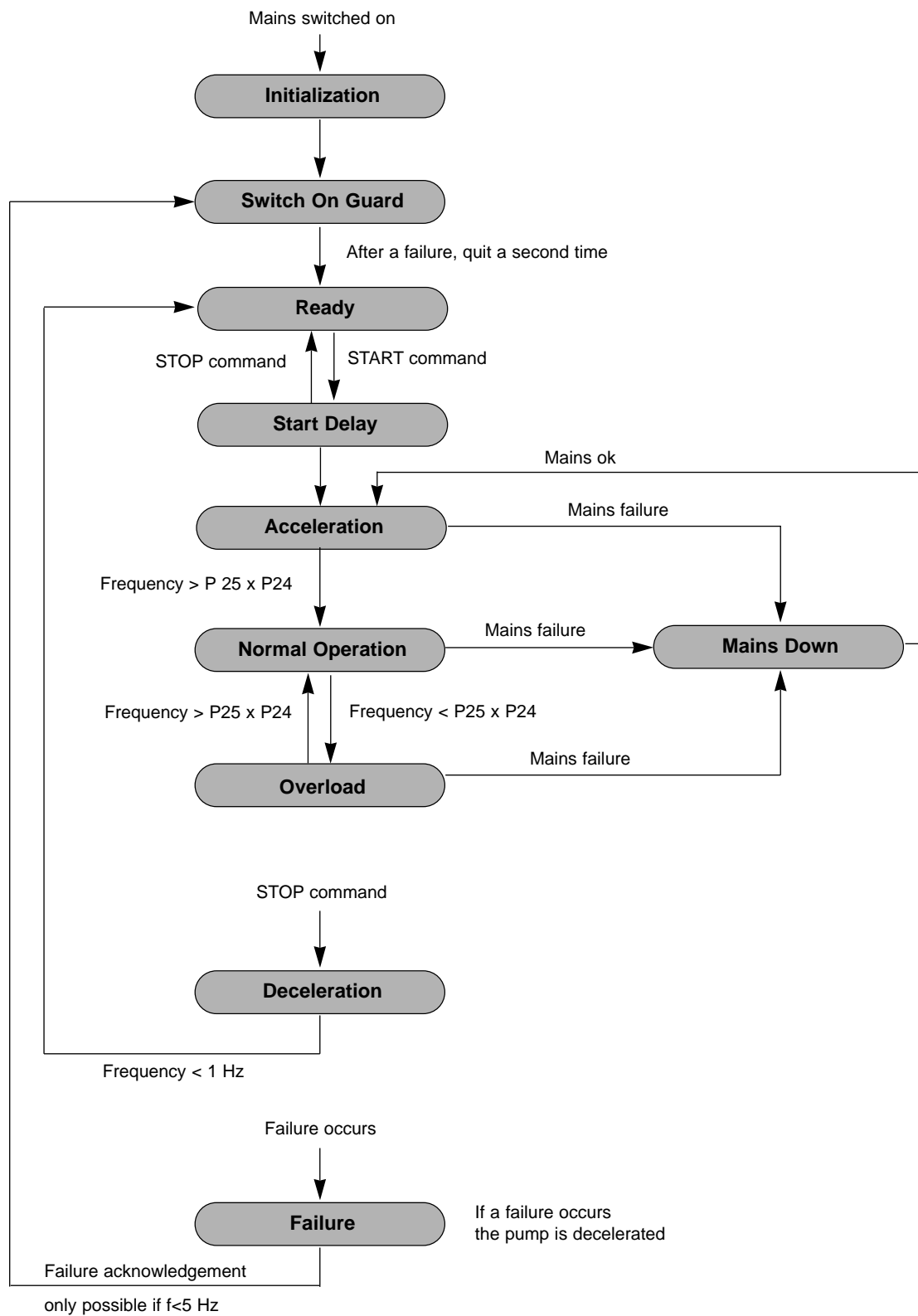

Parameter:
 P24 = Frequency setpoint
 P25 = Factor normal operation

Fig 35 Diagram: Operation status

4.3 Operating menu

4.3.1 Basic menu

Menu item	Description	Adjustable value / option				Unit	Access
		min. value	max. value	standard			
Ready	Operating display	-	-	-	-	-	-
Freq. Setpoint	Sets the speed for operation !! Every change is directly written into the pump's data storage and is valid immediately!!	150	480	480	Hz	r/w	
Operation Hours	Total operating hours of the pump	actual value			h	r	
Motor Temp.	Motor temperature	actual value			°C	r	
Converter Temp.	Temperature of the power electronic	actual value			°C	r	
Bearing Temp.	Temperature of the magnetic bearing	actual value			°C	r	
Actual Value TMS	Temperature of the Temperature Management System	actual value			°C	r	
Cooling Temp.	Cooling water temperature	actual value			°C	r	
Actual PVW 13	Rotor displacement in the magnetic bearing plane VW13	actual value			%	r	
Actual PVW 24	Rotor displacement in the magnetic bearing plane VW24	actual value			%	r	
Actual PZ 12	Rotor displacement in the magnetic bearing axis Z12	actual value			%	r	
Power	Power consumption of the drive	actual value			W	r	
Software Version	Actual software version	actual value			-	r	

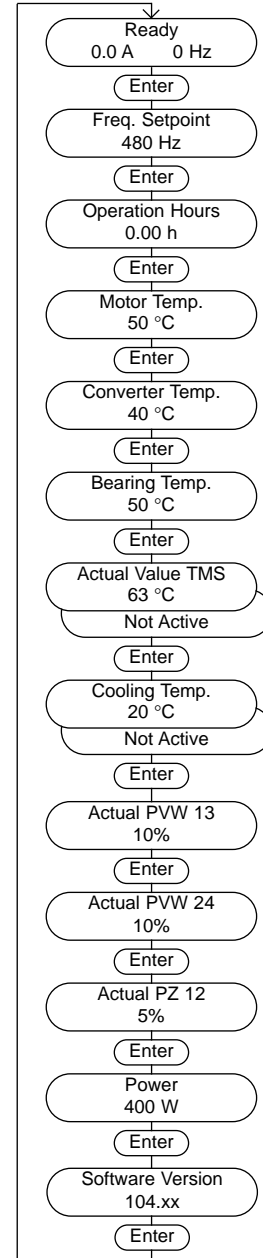

r (read) = value can **only** be read

r/w (read/write) = value can be read and written

4.3.2 Settings converter

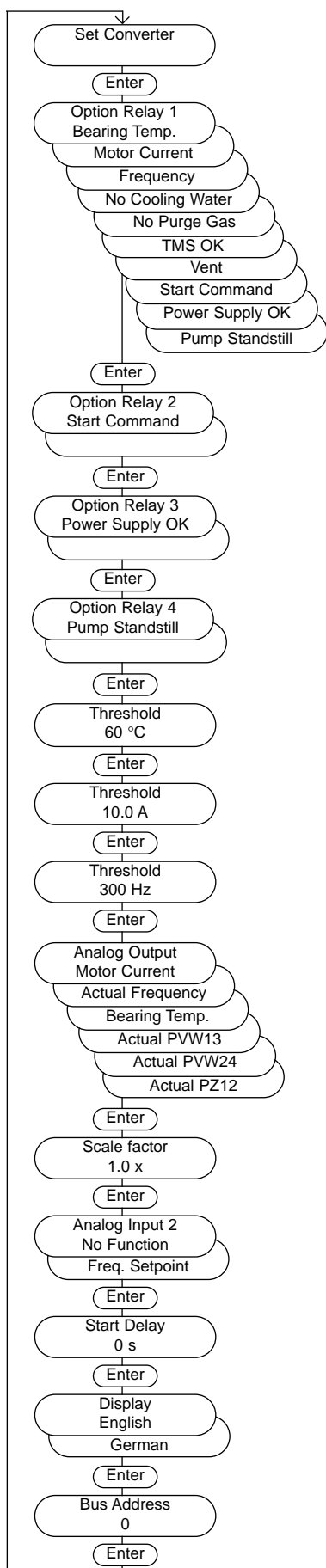

Menu item	Description	Adjustable value / option				Access
		min. value	max. value	standard	Unit	
Option Relay 1 (Relay 6)	Relay with change-over contact; the operator can select one of the functions described the thresholds are adjusted in the following menu items	Threshold bearing temperature reached			°C	r/w
		Threshold motor current reached			A	
		Threshold frequency reached			Hz	
		No cooling water no purge gas			-	
		TMS temperature o.k.			-	
		Vent			-	
		Start command applied			-	
		Power supply o.k.			-	
		Pump standstill			-	
Option Relay 2 (Relay 7)	The settings of the option relays 2 to 4 can be changed similar to option relay 1 but they cannot be stored in the pump's data storage device. After each power off the option relays 2 to 4 are in the default state.	Start command applied			-	
Option Relays 3 (Relay 8)		Power supply o.k.			-	
Option Relays 4 (Relay 9)		Pump standstill			-	
Threshold	Threshold bearing temp. for option relay	0	100	60	°C	r/w
Threshold	Threshold motor current for option relay	0	20	10	A	r/w
Threshold	Threshold frequency for option relay	0	480	300	Hz	r/w
Analog Output	Analog output 0...10V; the operator can select one of the functions described	Motor current; 20 A = 10Vxscale factor			V	r/w
		Act. frequency ; 500 Hz = 10Vxscale factor			V	
		Bearing temp. ; 100 °C = 10Vxscale factor			V	
		Actual PVW13; 100% = 10Vxscale factor			V	
		Actual PVW24; 100% = 10Vxscale factor			V	
		Actual PZ12; 100% = 10Vxscale factor			V	
Scale Factor	Scale factor for the analog output	0	2	1	-	r/w
Analog Input 2	Analog input 0...10V ; optionally frequency setpoint via analog input 2 (10V = max. frequency setpoint)	No function			-	r/w
		Function frequency setpoint			-	
Start Delay	Waiting time between start command and acceleration	0	1200	0	s	r/w
Display	Display language	English			-	r/w
		German			-	
Bus Address	Bus adress for the converter by operation via serial interface RS232/485	0	31	0	-	r/w

r (read) = value can **only** be read
r /w (read/write) = value can be read and written

4.3.3 Settings pump

Menu item	Description	Adjustable value / option				Access
		min. value	max. value	standard	Unit	
Normal Operation	Threshold for normal operation corresponding to the frequency setpoint	35	99	95	%	r/w
Max. Accel. Time	Monitor time for acceleration and overload	600	3600	1000	s	r/w
Pump Type	Displays the installed pump type	Installed pump type			-	r

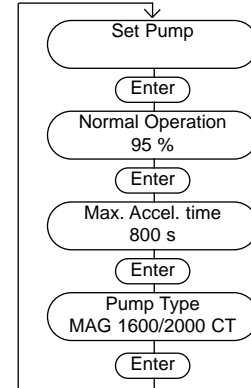

4.3.4 Settings temperature management system

Menu item	Description	Adjustable value / option				Access
		min. value	max. value	standard	Unit	
TMS Setpoint	Setpoint Temperature-Management-System	20	62	62	°C	r/w

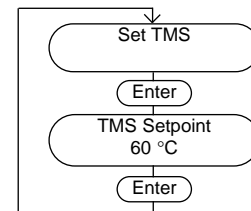

4.3.5 Settings purge / vent (Not active at MAG W 2010 CHT)

Menu item	Description	Adjustable value / option				Access
		min. value	max. value	standard	Unit	
Purge / Vent	The operator can select one of the beside standing options for purge and vent	Purge OFF		-	r/w	
		Purge ON		-		
		Controlling purge / vent via control plug X14				-
Option P / V	Displays the factory installed option for purge and vent	Installed option			-	r

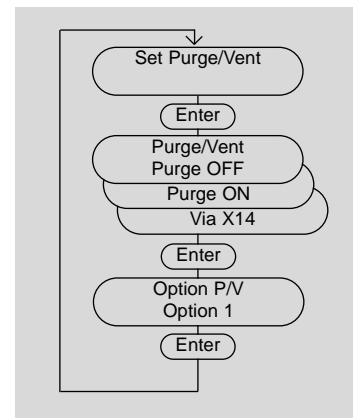

r (read) = value can **only** be read
 r /w (read/write) = value can be read and written

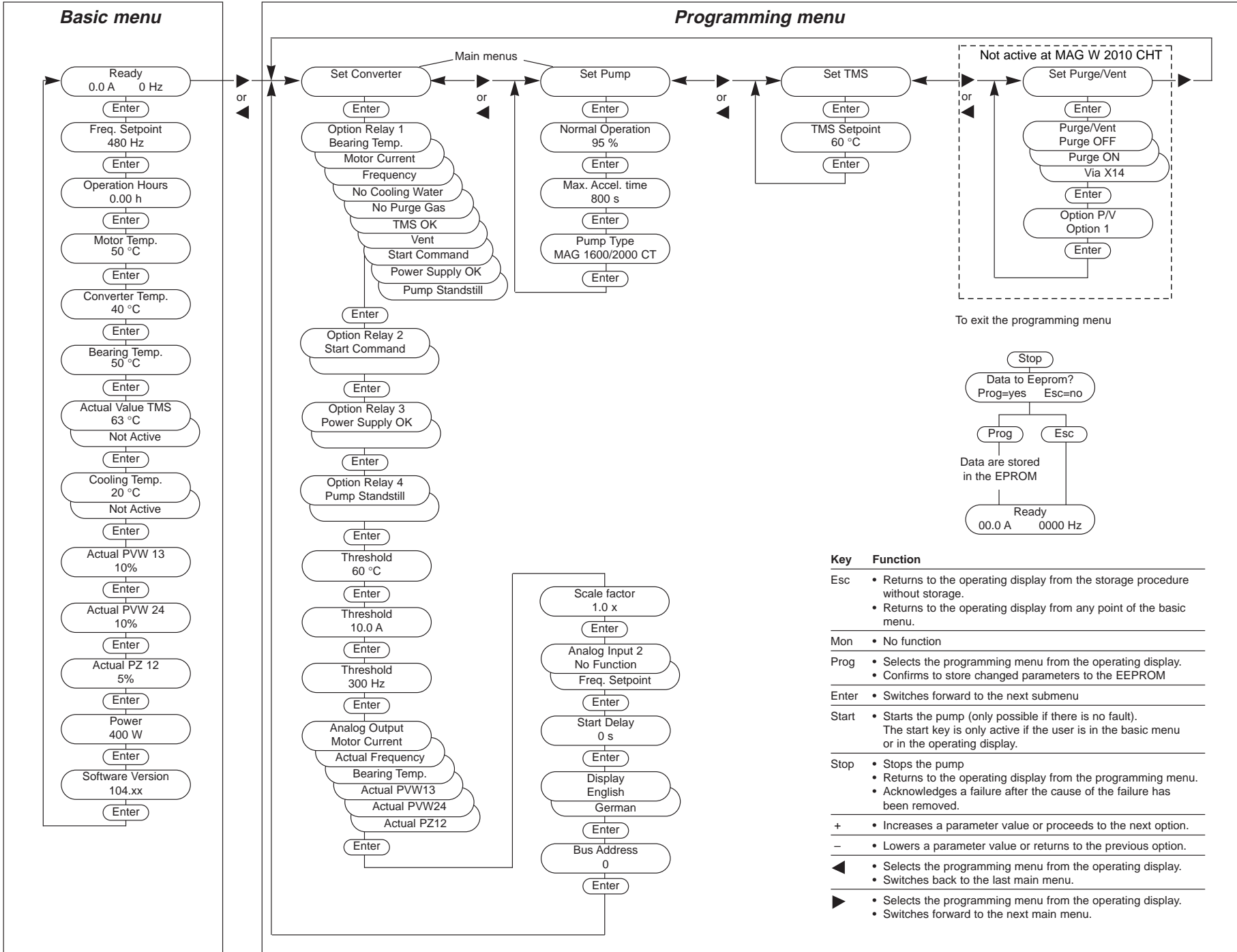

4.4 Temperature Management System

Function description

The TMS is only in function, when a MAG1600/2000 CT or CHT version is connected. The heater will be activated when the mains is switched on. The TMS controls the heating and water cooling to maintain the pump at the specified setpoint temperature.

Settings

The temperature (TMS) setpoint can be programmed via the front panel keys when the pump stands still.

Principally the factory presetting will be used. The setting is saved in the pump's memory chip. Before changing any setpoint value request Leybold!

For the setting refer to 4.3.4 Operating menu, Settings TMS.

Heat up

The setpoint temperature will be reached within 30 to 60 minutes depending on cooling water temperature and flow. If the flow is very high and the temperature low a high temperature setpoint might not be reached. For temperature sensitive applications observe the cooling water specifications (refer to Section 1.6 and 2.6).

Caution

In order to guarantee correct temperature setting of the pump it is required to provide the cooling water within the envelope described in Section 2.6.

TMS status code

The TMS status code is displayed on the operation display, see Section 4.

Actual temperature

The actual temperature is displayed on the operating display (refer to 4.3.1 Operating menu, Basic menu)

Signal TMS OK

If the actual TMS temperature lies in the range $\pm 5K$ from the setpoint temperature, the TMS OK signal can be output via the option relay. The option relay must be programmed for this function (refer to Section 2.8.3 Control plug X14, Relay outputs)

Warning message ($Temp > T_{set} + 5K$)

If the actual temperature exceeds the warning temperature the converter displays the message:

Warning TMS

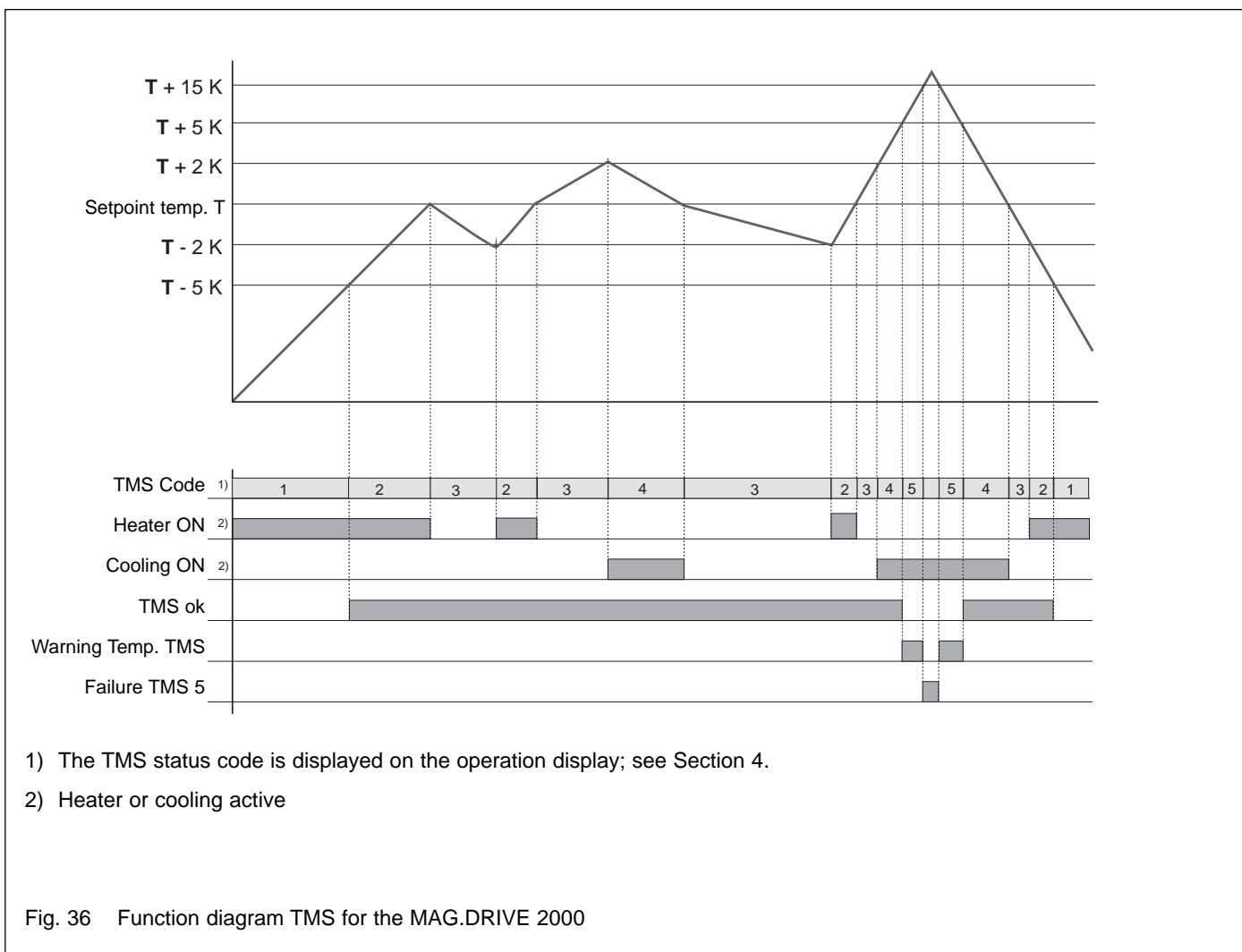

- 1) The TMS status code is displayed on the operation display; see Section 4.
- 2) Heater or cooling active

Fig. 36 Function diagram TMS for the MAG.DRIVE 2000

5 Maintenance

The MAG is nearly maintenance-free. Wear only occurs at the touch-down bearings when hard shocks have to be supported or when the pump frequently runs down without venting.

Maintenance is also required after removing the bearing cable during operation of the pump.

Under these conditions the rotor can not be controlled by the magnet bearing and the pump will have a full run down on the touch down bearing.

The rotor has to be changed after 40,000 hours of operation or after 5 years.

Depending on the installation site the converter may collect grime (dust, moisture) on the inside. Such contamination may lead to malfunctions, overheating or short circuits. Therefore the converter must be cleaned after 5 years.

Only the Leybold service can change the rotor and clean the converter.

5.1 Removing the pump from the system

MAG which have been used in semiconductor processes are contaminated by semiconductor process gases. Most of these gases form acids when exposed to moist air which causes serious corrosion damage to the pump.

To prevent corrosion damage during storage and shipping, use the seal kit.

Failure to seal a contaminated MAG voids the warranty.

The seal kit contains the following

- dry cartridge,
- plastic cap for forevacuum connection flange,
- plastic adhesive film and
- aluminum cover and screws for the high-vacuum connection flange.

Caution

For safety reasons we recommend to use a metal seal kit (order no. 200 07 901; see Fig. 38) for shipping of contaminated pumps. For storage of contaminated pumps during tool maintenance the seal kit provided with the pump can be used.

Proceed as follows to seal the turbomolecular pump immediately after removing it from your process.

Purge the pump for two hours with the backing pump running. This helps to remove a large quantity of the process gases from the pump. We recommend purging the pump via the intake flange and the purge valve with approx. 200 sccm.

Press the STOP button at the MAG.DRIVE and wait until the pump has come to a standstill.

Afterwards turn the mains switch to the „0“ position.

The cables between the MAG and MAG.DRIVE may be disconnected only after the MAG has come to a full still-stand **and** the mains is switched off.

Warning



When the pump has been pumping hazardous gases, ensure that proper safety precautions are taken before opening the intake or exhaust connections.



Use gloves or protective clothing to avoid skin contact with toxic or highly corrosive substances. Work under a fume hood if available.



Disconnect the cables from the pump.

Disconnect the cooling water lines. Remaining cooling water may flow out. Protect all parts below.

Remove 10 of the 12 bolts which hold the intake flange. The 2 remaining bolts must be directly opposite.

Disconnect the forevacuum line.

Support the pump with a lift-truck at the base plate and remove the 2 remaining bolts.

Clean the intake and forevacuum connection flange as necessary for good adhesion of tape.

Place the dry cartridge into the forevacuum port. Don't use loose crystals.

Firmly seal all ports with plastic adhesive film.

Cover the forevacuum connection port with its plastic cap.

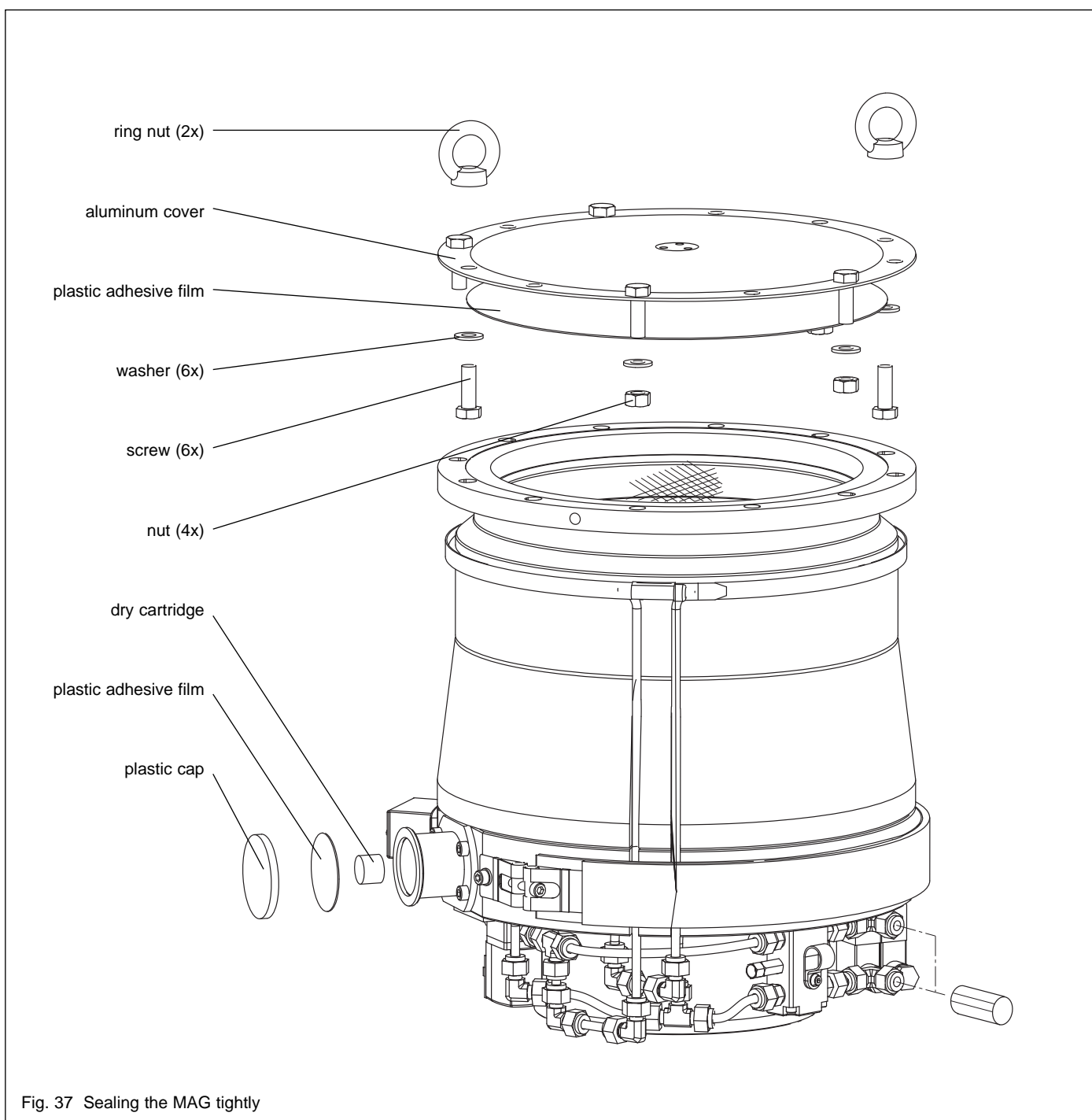

Seal the high-vacuum connection flange with the cover and the screws.

Pack the pump so that it may not be damaged during transportation. Particularly protect the flanges, the cooling water connectors and the current feedthrough.

5.2 Service at Leybold's

If you send a pump to Leybold indicate whether the pump is free of substances damaging to health or whether it is contaminated. If it is contaminated also indicate the nature of hazard. To do so, you must use a pre-printed form which we shall send to you upon request.

A copy of this form is printed at the end of the Operating Instructions: „Declaration of Contamination of Vacuum Equipment and Components“.

Either fasten this form at the pump or simply enclose it to the pump.

Don't pack the form with the pump into the PE bag.

This declaration of contamination is necessary to comply with legal requirements and to protect our staff.

Leybold must return any pump without a declaration of contamination to the sender's address.

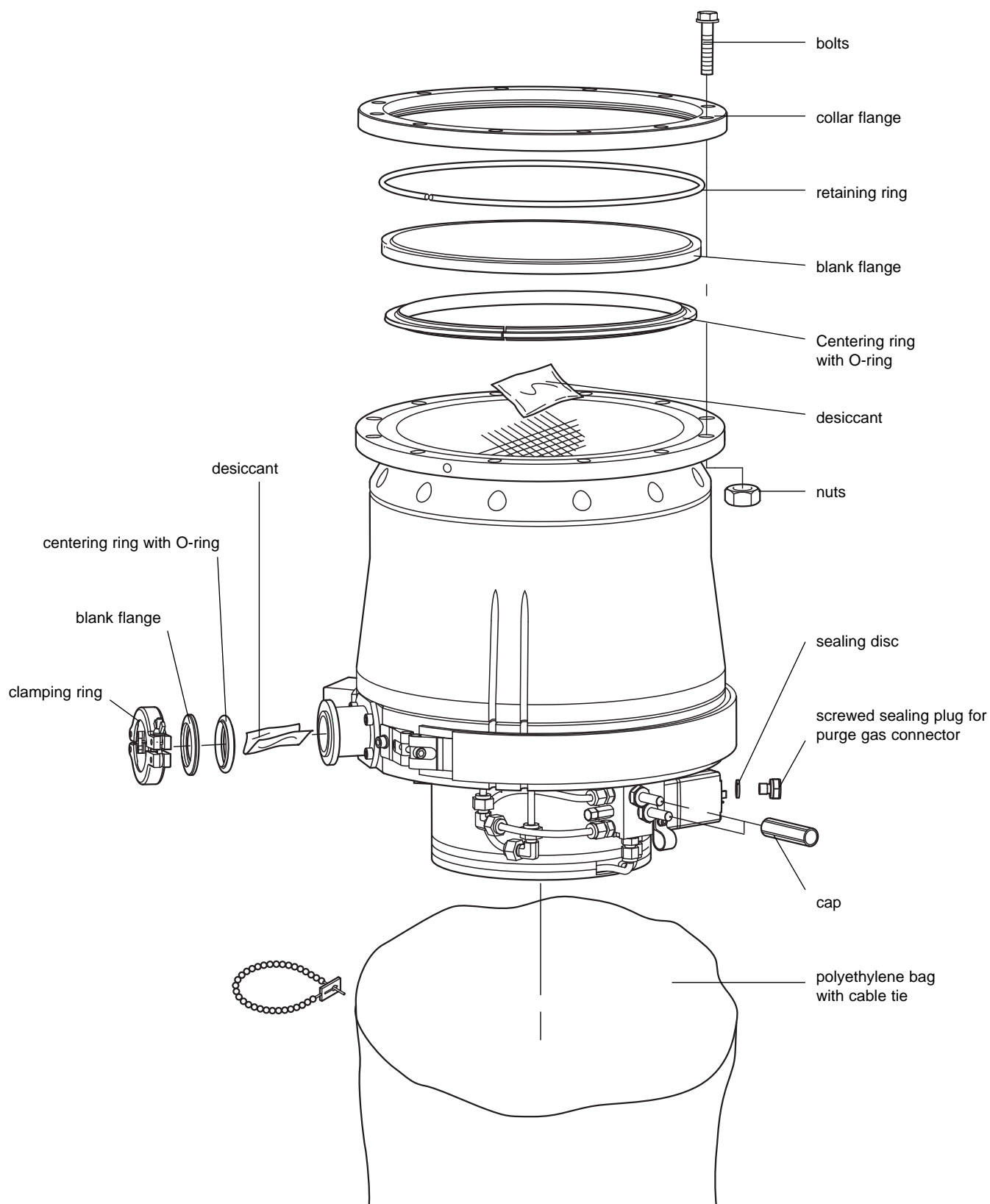

Fig. 38 Sealing the MAG tightly with the metal seal kit

6 Troubleshooting

In case of a malfunction, the MAG will be braked and the first line of the display shows

FAILURE

Malfunction messages can be cancelled once the pump has come to a stop and after the malfunction has been rectified; do so with the STOP function (button or serial interface).

Warning



The MAG shall be stopped completely and the mains power cord detached before you open the MAG.DRIVE. Since dangerous voltages may nonetheless be encountered, the housing must be opened only by a qualified electrician.

6.1 Warning messages

Warning Message on Display	Possible Cause	Measures
Motor Temp. Temperature sensor inside the motor reads a higher temperature value than the warning threshold (100 °C).	Motor temperature exceeds the warning threshold e.g. due to a high gas load. Drive failure or internal converter failure.	Take the actual motor temperature reading from the display; see Section 4.3.1. Reduce gas load. If the warning persists contact Leybold service. Contact Leybold service.
Bearing Temp. Temperature sensor inside the pump reads a higher temperature value than the warning threshold (75 °C).	Cooling water flow too low or cooling water temperature too high. Frequent acceleration and deceleration of the pump. Temperature at the high-vacuum connection flange or at the isolation valve is much higher than 85 °C. Water valve malfunction.	Apply cooling water according to specifications. Check cooling water tubes for deposits. See also Section 2.6. Allow pump to cool down between the cycles. Check chamber temperature. If the red LED at the water valve is on disconnect and connect the connector. The valve must make noises. If not contact Leybold.
Converter Temp. Temperature sensor inside of the converter reads a higher temperature value than the warning threshold (70 °C).	Frequent acceleration and deceleration of the pump. No sufficient air circulation.	Allow converter to cool down between the cycles. Refer to Section 2.8 for the correct mounting of the converter in a rack; max. ambient temperature 45 °C.
Cooling Temp. Temperature sensor at cooling water block reads a higher temperature value than the warning threshold (45 °C).	Cooling water flow too low or cooling water temperature too high.	Apply cooling water according to specifications. Check cooling water tubes for deposits. See also Section 2.6.

Warning Message on Display	Possible Cause	Measures
<p>TMS TMS temperature sensor reads a temperature higher than the TMS setpoint +5 °C.</p>	<p>Cooling water flow too low or cooling water temperature too high. Wrong TMS temperature setpoint. Temperature at the high-vacuum connection flange or at the isolation valve is much higher than 85 °C. Water valve malfunction.</p>	<p>Apply cooling water according to specifications. Check cooling water tubes for deposits. See also Section 2.6. Check the TMS setpoint (default 62 °C). For the correct setting refer to Section 4.3.4. Check chamber temperature. If the red LED at the water valve is on disconnect and connect the connector. The valve must make noises. If not contact Leybold.</p>
<p>Unbalanc. PVW13 Unbalanc. PVW24 Unbalanc. PZ12 A rotor displacement exceeding the warning threshold occurred. The code designates the affected axis.</p>	<p>Mechanical shocks, perhaps due to tool maintenance. Shock venting. Converter failure.</p>	<p>If warning message persists contact Leybold service. Check the chamber pressure during operation. Contact Leybold service.</p>
<p>Overload The rotational speed dropped below normal operation frequency.</p>	<p>Backing pressure too high during operation. Parameters „Normal Operation“ are not set correctly.</p>	<p>Reduce backing pressure. Additionally, check process gas flow. Set parameter „Normal Operation“ to default 95%. Refer also to Section 4.3.3.</p>
<p>Mains down The converter is in the generator mode.</p>	<p>Mains interrupted or converter switched off during operation of the pump.</p>	<p>Reconnect converter to the mains. Switch on the converter.</p>
<p>Op. Without Purge The warning indicates that a C/CT type of pump is operated while the purge gas valve is closed.</p>	<p>Purge gas function disabled.</p>	<p>Set purge gas function to Purge ON. (Key panel or control connector X14).</p>
<p>Protection The pump drive is blocked.</p>	<p>Emergency off active.</p>	<p>Deactivate „Emergency off“ via control plug X14.</p>
<p>PK Communication Converter does not communicate with the memory chip inside of the pump.</p>	<p>BEARING cable damaged. Memory chip inside of magnetic bearing cartridge malfunctioning.</p>	<p>Check BEARING connector and cable for damages or bent pins. Contact Leybold service if the cable is damaged. Contact Leybold service.</p>

6.2 Failure messages

Failure Message on Display	Possible Cause	Measures
<p>Motor Temp. Temperature sensor inside the motor reads a higher temperature value than the failure threshold (100 °C).</p>	<p>Motor temperature exceeds the failure threshold e.g. due to a high gas load.</p> <p>Motor temperature sensor defective.</p> <p>BEARING cable or connector damaged.</p> <p>Converter failure.</p>	<p>Acknowledge failure message.</p> <p>Take the actual motor temperature reading from the display; see Section 4.3.1. Reduce gas load. If the warning persists contact Leybold service.</p> <p>Step 1: Check pump (temperature sensor) Check pump connector X23. In particular measure resistance between pins X23/x and X23/w. The resistance is typically $2k\Omega \pm 1\%$. In case of abnormal values ($> 3.4 k\Omega$) are measured contact Leybold service.</p> <p>Step 2: Check BEARING cable If step 1 was successful do the following: Check BEARING cable for bent pins Measure the resistance between pins X20/x and X20/w with the cable connected to the pump. The resistance is typically $2k\Omega \pm 1\%$. Replace the cable if it is damaged or in case the measurement of the resistance shows abnormal values ($> 3.4 k\Omega$) now. Contact Leybold service.</p>
<p>Cooling Temp. Temperature sensor at cooling water block reads a higher temperature value than the failure threshold (55 °C).</p>	<p>Cooling water flow too low or cooling water temperature too high.</p> <p>Pt 100 (cooling water temperature sensor) damaged.</p> <p>TMS cable or connectors damaged.</p> <p>Converter failure.</p>	<p>Apply cooling water according to specifications. Check cooling water tubes for deposits. See also Section 2.6.</p> <p>Step 1: Check cooling water temperature sensor Check pump connector X30. In particular measure resistance between pins X30/S and X30/V. The resistance is typically between 110Ω and 130Ω (20 °C to 70 °C).</p> <p>Step 2: Check TMS cable and connectors If step 1 was successful do the following: Check TMS cable for bent pins Measure the resistance between pins X26/W and X26/V with the TMS cable connected to the pump. The resistance is typically between 110Ω and 130Ω (20 °C to 70 °C). Replace TMS cable if it is damaged or in case the measurement of the resistance shows abnormal values now. Contact Leybold service.</p>

Failure Message on Display	Possible Cause	Measures
<p>Bearing Temp. Temperature sensor inside the pump reads a higher temperature value than the failure threshold (76 °C).</p>	<p>Cooling water flow too low or cooling water temperature too high.</p> <p>Frequent acceleration and deceleration of the pump.</p> <p>Pt 100 (temperature sensor bearing) damaged.</p> <p>BEARING cable or connectors damaged.</p> <p>Temperature at the high-vacuum connection flange or at the isolation valve is much higher than 85 °C.</p> <p>Water valve malfunction.</p> <p>Converter failure.</p>	<p>Apply cooling water according to specifications. Check cooling water tubes for deposits. See also Section 2.6.</p> <p>Allow pump to cool down between the cycles.</p> <p>Step 1: Check pump (temperature sensor) Check pump connector X23. In particular measure resistance between pins X23/v and X23/u as well as between pins X23/v and X23/t. The resistance is typically between 110 Ω and 130 Ω (20 °C to 70 °C). In case abnormal values are measured contact Leybold service.</p> <p>Step 2: Check BEARING cable If step 1 was successful do the following: Check BEARING cable for bent pins Measure the resistance between pins X20/v and X20/u as well as between pins X20/v and X20/t with the cable connected to the pump. The resistance is typically between 110 Ω and 130 Ω (20 °C to 70 °C). Replace the cable if it is damaged or in case the measurement of the resistance shows abnormal values now.</p> <p>Check chamber temperature.</p> <p>If the red LED at the water valve is on disconnect and connect the connector. The valve must make noises. If not contact Leybold.</p> <p>Contact Leybold service.</p>
<p>Converter Temp. Temperature sensor inside of the converter reads a higher temperature value than the failure threshold (90 °C).</p>	<p>Frequent acceleration and deceleration of the pump.</p> <p>No sufficient air circulation.</p> <p>Converter failure.</p>	<p>Allow converter to cool down between the cycles.</p> <p>Refer to Section 2.8 for the correct mounting of the converter in a rack; max. ambient temperature 45 °C.</p> <p>Contact Leybold service.</p>
<p>Overload PZ 12 Overload PV 13 Overload PW 24 An abnormal displacement of the rotor occurred at frequencies between 0 and 5 Hz. The code designates the affected axis.</p>	<p>Mechanical shocks, possibly due to tool maintenance when the rotor stands still.</p> <p>Pump is still protected with transport seal on power up.</p> <p>BEARING cable or connector damaged.</p>	<p>Acknowledge failure message and restart the pump. If failure message persists contact Leybold service.</p> <p>Remove transport seal; see Section 2.4.</p> <p>Check BEARING connector and cable for bent pins. Contact Leybold service if the cable is damaged.</p>

Failure Message on Display	Possible Cause	Measures
<p>MB An abnormal displacement of the rotor occurred at frequencies between 146 Hz and 480 Hz.</p>	<p>Mechanical shocks, possibly due to tool maintenance.</p> <p>Shock venting.</p> <p>Converter failure.</p>	<p>Acknowledge failure message and restart the pump. If failure message persists contact Leybold service.</p> <p>Check the chamber pressure during the operation. Refer to Section 3.1 for correct venting of the pump.</p> <p>Contact Leybold service.</p>
<p>MB-Code Wrong Magnetic bearing controller does not work.</p>	<p>Converter failure.</p>	<p>Contact Leybold service.</p>
<p>Starting Time The frequency has not reached 40 Hz 2 minutes after the start command was applied.</p>	<p>Backing pressure too high during start-up.</p> <p>Rotor blocked.</p>	<p>Reduce backing pressure.</p> <p>Check if the rotor rotates freely. Contact Leybold service if the rotor is damaged or blocked.</p>
<p>Accel. Time The pump does not reach the normal operation frequency after the set maximum acceleration time.</p>	<p>Backing pressure too high during start-up.</p> <p>Parameter „Accel. Time“ is not set correctly.</p>	<p>Reduce backing pressure.</p> <p>Set parameter „Accel. Time“ to default 1000 s; see Section 4.3.3.</p>
<p>Overload Time The rotational speed has dropped below normal operation frequency and stays there for longer than the maximum „Accel. Time“.</p>	<p>Backing pressure too high during operation.</p> <p>Parameters „Accel. Time“ or „Normal Operation“ are not set correctly.</p>	<p>Reduce backing pressure. Additionally check process gas flow.</p> <p>Set parameter „Normal Operation“ to default 95 % and parameter „Accel. Time“ to default 1000 s; see Section 4.3.3.</p>
<p>Shutdown Freq. Rotational speed dropped below the shutdown frequency threshold (140 Hz).</p>	<p>Backing pressure too high during operation.</p>	<p>Reduce backing pressure. Additionally check process gas flow.</p>
<p>Cooling Temp. SC The cooling water temperature sensor reads a temperature lower than 1 °C.</p>	<p>Temperature sensor Pt 100 short-circuited.</p> <p>TMS cable short-circuited.</p> <p>Converter failure.</p>	<p>Repeat step 1 of „failure Cooling Temp.“. Contact Leybold service if the resistance of the sensor is less than 100 Ω.</p> <p>Repeat step 2 of „failure Cooling Temp.“. Contact Leybold service if the resistance of the sensor is less than 100 Ω.</p> <p>Contact Leybold service.</p>

Failure Message on Display	Possible Cause	Measures
<p>Bearing Temp. SC The magnetic bearing temperature sensor reads a temperature lower than 1 °C.</p>	<p>Temperature sensor Pt 100 short-circuited.</p> <p>BEARING cable short-circuited.</p> <p>Converter failure.</p>	<p>Repeat step 1 of „failure Bearing Temp.“. Contact Leybold service if the resistance of the sensor is less than 100 Ω.</p> <p>Repeat step 2 of „failure Bearing Temp.“. Contact Leybold service if the resistance of the sensor is less than 100 Ω.</p> <p>Contact Leybold service.</p>
<p>Motor Temp. SC The motor temperature sensor reads a temperature lower than 1 °C.</p>	<p>Temperature sensor KTY short-circuited.</p> <p>BEARING cable short-circuited.</p> <p>Converter failure.</p>	<p>Repeat step 1 of „failure Motor Temp.“. Contact Leybold service if the resistance of the sensor is less than 1.62 kΩ.</p> <p>Repeat step 2 of „failure Motor Temp.“. Contact Leybold service if the resistance of the sensor is less than 1.62 kΩ.</p> <p>Contact Leybold service.</p>
<p>Connection pump</p>	<p>BEARING cable not connected.</p> <p>Converter failure.</p>	<p>Check if the BEARING cable is connected to the pump and the converter. Acknowledge failure message.</p> <p>Contact Leybold service.</p>
<p>Frequency XX* Abnormal motor current or frequency *XX is a code no. between 43 and 55. It helps the Leybold service to find the cause of the failure.</p>	<p>The rotor frequency exceeds 515 Hz.</p> <p>Converter failure.</p>	<p>Acknowledge failure message. If failure persists contact Leybold service.</p> <p>Contact Leybold service.</p>
<p>No Motor Current</p>	<p>On START command: DRIVE cable not connected or connectors damaged.</p> <p>Resultant message after activating „Emergency off“.</p> <p>DRIVE cable interrupted during operation of the MAG.</p>	<p>Check cables and connectors, straighten pins if required.</p> <p>Deactivate „Emergency off“ via control plug X14 and acknowledge failure message.</p> <p>Reconnect or replace DRIVE cable.</p>
<p>TMS 1 The converter measures a heating current of less than 300 mA when heater is on.</p>	<p>Fuse TMS blown.</p> <p>Heating element or internal pump connection damaged.</p> <p>TMS/DRIVE cable or connectors damaged.</p> <p>Converter failure.</p>	<p>Step 1: Check fuse Replace fuse TMS (F4A, 5x20 mm) if blown.</p> <p>Step 2: Check pump (heating element) Check if the connector of the heating element is connected. Check pump connector X30. In particular measure resistance between pins X30/A and X30/B. The resistance is typically between 70 Ω and 75 Ω. In case abnormal values are measured contact Leybold service.</p> <p>Step 3: Check TMS/DRIVE cable If step 2 was successful do the following: Check TMS/DRIVE cable for bent pins Measure resistance between pins X21/b and X21/d with the cable connected to the pump. The resistance is typically between 70 Ω and 75 Ω. Replace the cable if it is damaged or in case the measurement of the resistance shows abnormal values now. Contact Leybold service.</p>

Failure Message on Display	Possible Cause	Measures
<p>TMS 2 The converter measures a heating current of more than 4 A.</p>	<p>Overvoltage. Heating element defective. Converter failure.</p>	<p>Check the line voltage (200-240 V +10% / -15%). Repeat step 2 of failure TMS 1. In case the measured value is less than 60 Ω contact Leybold service. Contact Leybold service.</p>
<p>TMS 3 TMS temperature sensor reads a temperature higher than 99 °C.</p>	<p>TMS sensor damaged. TMS/DRIVE cable damaged. Converter failure.</p>	<p>Step 1: Check TMS sensor Check pump connector X30. In particular measure resistance between pins X30/F and X30/H as well as between pins X30/H and X30/G. The resistance is typically between 110 Ω and 130 Ω (20 °C to 70 °C). Step 2: Additional TMS sensor test If temperature sensor TMS (Pt 100) has the correct resistance, unplug it while the pump is on power. The water valve should open instantly with a clicking noise and a red LED inside the cooling water valve connector lighting up. This LED should be on if the actual TMS temperature is higher than the TMS setpoint + 2 °C. Contact Leybold service if the sensor is defective. Step 3: Check TMS/DRIVE cable Check TMS/DRIVE cable connector X21. In particular measure resistance between pins X21/K and X21/M as well as between pins X21/K and X21/L. The resistance is typically between 110 Ω and 130 Ω (20 °C to 70 °C). Contact Leybold service if the TMS/DRIVE cable is damaged. Contact Leybold service.</p>
<p>TMS 4 TMS temperature sensor reads a temperature lower than 1 °C.</p>	<p>TMS sensor short-circuited. TMS/DRIVE cable short-circuited. Converter failure.</p>	<p>Repeat steps 1 and 2 of failure TMS 3. Contact Leybold service if the sensor is defective. Repeat step 3 of failure TMS 3. Contact Leybold service if the cable is damaged. Contact Leybold service.</p>
<p>TMS 5 TMS temperature sensor reads a temperature higher than the TMS setpoint + 15 °C.</p>	<p>Cooling water flow too low or cooling water temperature too high. Cooling water valve malfunctioning. Wrong TMS temperature setpoint. Temperature at the high-vacuum connection flange or at the isolation valve is much higher than 85 °C.</p>	<p>Apply cooling water according to specifications. Check cooling water tubes for deposits. See also Section 2.6. Repeat step 2 of failure TMS 3. Contact Leybold service if cooling water valve is malfunctioning. Check the TMS setpoint (default 62 °C). For the correct settings refer to Section 4.3.4. Check chamber temperature.</p>

6.3 Malfunctions

Malfunction	Possible Cause	Measures
Converter dead, LED „mains“ does not light up after switching on.	No power supply. Fuse F1 blown or converter failure.	Check the line voltage. Contact Leybold service.
Display malfunction, confusing messages. No reaction when pressing keys.	Converter failure.	Switch the converter off and on again. If the converter still malfunctions contact Leybold service.
Vacuum chamber pressure rises above normal backing pressure while the pump is stopped.	Purge gas and venting valve open or malfunctioning.	Open and close purge gas and/or venting valve via control plug X14. LED on the valve must light up and a clicking noise can be heard. Foreline pressure drops while the valve is closed.
No purge gas flow	Valve malfunctioning.	Set purge flow according to specification.
Base pressure not reached.	Degassing surfaces of rotor and stator. If the pump was stored in a humid environment or was exposed to humid ambient air all surfaces will be covered with condensation.	Leave the pump system run for 3 to 5 hours to reach a pressure below 10^{-5} mbar.
MAG does not heat up.	TMS failure.	See TMS failures.
Display blurred.	Ambient temperature too high or too low.	Operate the converter according to the specifications.

EEC Manufacturer's Declaration

in the sense of EEC Directive on Machinery 89/392/EWG, Annex IIb

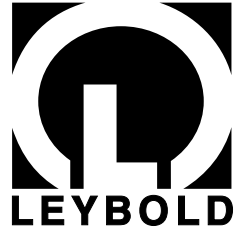

We - LEYBOLD Vacuum GmbH - herewith declare that operation of the incomplete machine defined below, is not permissible until it has been determined that the machine into which this incomplete machine is to be installed, meets the regulations of the EEC Directive on Machinery.

At the same time we herewith certify conformity with EEC Directive on Low-Voltages 73/23/EWG.

When using the appropriate Leybold accessories, e.g. connector lines and when powering the pump with the specified Leybold frequency converters, the protection level prescribed in the EMC Guidelines will be attained.

Designation: Turbomolecular pump

Model: MAG W 2010 CHT

Catalogue number: 121 31

Applied harmonized standards:

- | | |
|---------------------|-----------|
| • EN 292 Part 1 & 2 | Nov. 1991 |
| • EN 1012 Part 2 | 1996 |
| • EN 60 204 | 1993 |

Applied national standards and technical specifications:

- | | |
|----------------|------------|
| • DIN 31 001 | April 1983 |
| • DIN ISO 1940 | Dec. 1993 |

Cologne, May 19, 1999

Handwritten signature of Dr. Mattern-Klosson in black ink.

Dr. Mattern-Klosson, Business Area Manager
Turbomolecular pumps

Cologne, May 19, 1999

Handwritten signature of Stölle in black ink.

Stölle, Design Manager
Turbomolecular pumps

EC declaration of manufacture

in accordance with Art. 4 paragraph 2 of EC directive 89/392/EEC

Document No.: **MSR 0898 / MAG.DRIVE 2000**
Manufacturer: **REFU elektronik GmbH**
Product Identification: **MAG.DRIVE 2000**
Catalog No.: **121 35, 121 36, 121 37, 121 44**

The product indicated solely for fitting in another machine. Commissioning is prohibited until the conformity of the end product with EC directive 89/392/EEC has been established.

Standards applied: **EN 60204-1**
EN 61010-1

REFU elektronik GmbH
Metzingen, 1999.04.15



.....
Harald Lautz,
Head of Business Unit OEM



.....
Herbert Schleicher,
Manager of Development OEM

The safety notes given in the product documentation must be observed.

EC declaration of conformity

Document No.: **NSR 0898 / MAG.DRIVE 2000**
Manufacturer: **REFU elektronik GmbH**
Product Identification: **MAG.DRIVE 2000**
Catalog No.: **121 35, 121 36, 121 37, 121 44**

Herewith, we declare that this product, as a result of its design and type of construction, and the version marketed by us, correspond to the basic health and safety regulations specified in the EEC Directives.

This declaration is no longer valid if the product is modified without us being in full agreement.

The product conforms to the EEC Low-Voltage Directive (73/23/EEC).

Standards applied: **EN 61010-1**

Display the CE-mark: **August 1998**



REFU elektronik GmbH
Metzingen, 1999.04.15

A handwritten signature in black ink, appearing to be 'HL', written over a dotted horizontal line.

Harald Lautz,
Head of Business Unit OEM

A handwritten signature in black ink, appearing to be 'HS', written over a dotted horizontal line.

Herbert Schleicher,
Manager of Development OEM

The safety notes given in the product documentation must be observed.

Factory certificate

Document No.: **EMV 0898 / MAG.DRIVE 2000**
Manufacturer: **REFU elektronik GmbH**
Product Identification: **MAG.DRIVE 2000**
Catalog No.: **121 35, 121 36, 121 37, 121 44**

The named product, when put to its intended use, satisfies the requirements of Directive 89/336/EEC concerning electromagnetic compatibility.

The applicable measurements were made taking into account the following standards:

EN 50081 Part 2
EN 50082 Part 2

Note

Attention must be paid to the information provided on proper installation with respect to electromagnetic compatibility and to other pertinent notes in the documentation supplied with the product, as well as to the relevant information concerning electrical connection.

REFU elektronik GmbH
Metzingen, 1999.04.15

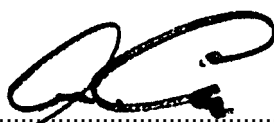

Harald Lautz,
Head of Business Unit OEM



Herbert Schleicher,
Manager of Development OEM



**NRTL
LISTED**

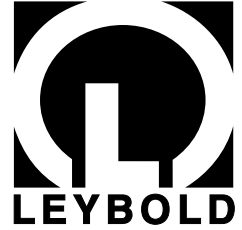

The system MAG 2000

- turbomolecular pump
- connecting cables
- frequency converter

has been tested by the TÜV Rheinland of North America according to the requirements of

- **NRTL**
(used standards UL 3101, EN 61010) and
- **SEMI S2**

The components are in compliance to the tested standards.

The tested system includes the following components:

Turbomolecular pump MAG (W) 1600/2000,
Cat. Nos. 121 31, 121 32
894 14, 894 15, 894 16, 894 17,
894 28, 894 29, 894 30, 894 31

Frequency converter MAG.DRIVE 2000,
Cat. Nos. 121 35, 121 37, 121 44

Plug-in control, Cat. No. 121 36

BEARING cable, Cat. Nos.
121 17, 121 19, 121 21, 121 25, 121 29

DRIVE/TMS cable, Cat. Nos.
121 18, 121 20, 121 22, 121 26, 121 30

NRTL Report No. E9814034E01

Form TMP-1 ... Turbopump Field Failure Report

Field Service IR No.: _____ RMA No. (if returning to factory): _____

Service Center: _____

Customer: _____

Turbopump Model: _____ Turbopump Pump Part Number: _____

Turbopump Serial Number: _____

Complaint: _____

Process: _____

OEM Equipment Name and Model: _____

Process Gas: _____

Was the turbopump replaced? Yes; No.

If yes, replacement pump P/N: _____ replacement pump S/N: _____

Date Installed: _____ Date Removed: _____

Date Received: _____

Date Examined: _____ Examined by: _____

Received Condition: _____

Findings: _____

Cause of Failure: _____

Recommendations: _____

Remarks/Questions: _____



Operating Instructions for MAG 2000 series

Operating Instructions	Valid for pumps	Valid for Converters
GA 05.130/1.02 (December 1997)	MAG W 1600 C, CT (Operation diagram & pumping speed curve missing) MAG 2000 C, CT MAG W 2000 C, CT	MAG.DRIVE L MAG.DRIVE L2 (Troubleshooting incomplete)
GA 05.130/2.02 (February 1998)	MAG W 1600 C, CT MAG 2000 C, CT MAG W 2000 C, CT	MAG.DRIVE L MAG.DRIVE L2 (Troubleshooting incomplete)
GA 05.130/3.02 (May 1998)	MAG 1600 C, CT MAG W 1600 C, CT MAG 2000 C, CT MAG W 2000 C, CT	MAG.DRIVE L MAG.DRIVE L2
GA 05.135/1.02 (August 1998)	MAG 1600 C, CT MAG W 1600 C, CT MAG 2000 C, CT MAG W 2000 C, CT	MAG.DRIVE 2000
GA 05.135/2.02 (October 1998)	MAG 1600 C, CT MAG W 1600 C, CT MAG 2000 C, CT MAG W 2000 C, CT	MAG.DRIVE 2000
GA 05.135/3.02 (June 1999)	MAG 1600 C, CT MAG W 1600 C, CT MAG 2000 C, CT MAG W 2000 C, CT	MAG.DRIVE 2000 including NRTL & SEMI S2 certifications
GA 05.136/1.02 (July 1998)	MAG W 2010 C 3 Beta site units	MAG.DRIVE 2000
GA 05.136/2.02 (October 1998)	MAG W 2010 C	MAG.DRIVE 2000
GA 05.139/1.02 (June 1999)	MAG W 2010 CHT	MAG.DRIVE 2000 including NRTL & SEMI S2 certifications



LEYBOLD VAKUUM GmbH

Bonner Strasse 498 (Bayenthal)
D-50968 Cologne

Tel.: + 49 (221) 347-0

Fax: + 49 (221) 347-1250

<http://www.leyboldvac.de>

e-mail: documentation@leyboldvac.de