

Vacuum Solutions

Application Support

Service



LEYBOLD VACUUM

GA 05.218/3.02



FOR SALES AND SERVICE PLEASE CALL:

PTB SALES T :: 866.332.0500  
F :: 626.334.2151  
www.ptbsales.com

DATE SERVICED: \_\_\_\_\_

**VIEW OUR INVENTORY**

**TURBOTRONIK**  
**NT 340 M**  
**NT 340 MA**  
**NT 341 MA**

Electronic frequency  
converters

Cat.No.  
857 29/30/31  
857 32  
857 34

**Operating Instructions**

**Contents**

	Page
1 Description .....	2
1.1 Design and Function .....	2
1.2 Standard Specification .....	3
1.3 Technical Data .....	5
1.4 Ordering Data .....	6
2 Connection .....	7
2.1 Setting the Mains Voltage .....	7
2.2 Connecting the TURBOVAC .....	7
2.3 Connecting the Forevacuum Pump .....	7
2.4 TURBOTRONIK NT 340 M & MA without temperature control (TCU): Connecting the Cooling, Venting Device and the Flange Heater .....	8
2.5 TURBOTRONIK NT 340 MA with temperature control (TCU): Connecting the Temperature Control and the Forevacuum Valve .....	10
2.6 TURBOTRONIK NT 341 MA: Connecting the Temperature Control and the Forevacuum Valve .....	12
2.7 Connecting the Interface .....	14
2.8 Connecting the Remote Control .....	14
2.9 Modifying the Relay "Failure" (Option) .....	16
2.10 Installing the TURBOTRONIK .....	16
3 Operation .....	18
3.1 Start-up .....	18
3.2 Start-up of the TURBOVAC .....	18
3.3 Bakeout of the TURBOVAC .....	18
3.4 Operation .....	19
3.5 Shut-down of the TURBOVAC .....	19
3.6 Venting of the TURBOVAC .....	19
3.7 Power Failure - Linecord Interruption .....	19
3.8 Shut-down of the TURBOTRONIK .....	20
3.9 Maintenance .....	20
4 Troubleshooting .....	21
EC Conformance Declaration .....	22

**Warning**

Indicates procedures that must be strictly observed to prevent hazards to persons.

**Caution**

Indicates procedures that must be strictly observed to prevent damage to, or destruction of the appliance.

**Figures**

The references to diagrams, e. g. (2/10), consist of the Fig. No. and the Item No. in that order.

We reserve the right to alter the design or any data given in these Operating Instructions.

The illustrations are not binding.

# 1 Description

## 1.1 Design and Function

The TURBOTRONIK NT 340 M, NT 340 MA, and NT 341 MA are electronic frequency converters. They operate turbomolecular pumps TURBOVAC.

The TURBOTRONIK NT 340 MA and NT 341 MA are prepared for operation with an additional temperature control unit. This temperature control unit is part of a temperature control which maintains the temperature of the TURBOVAC within a narrow control range.

The TURBOTRONIK converts the single-phase mains voltage into a regulated DC power supply. The unit's electronic circuitry then switches this DC power supply onto the four stator windings of the TURBOVAC's commutatorless DC motor in a cyclical sequence.

This electronic switching system uses Hall probes, and replaces the commutator normally found in DC motors. A digital controller keeps the speed of the motor constant.

The TURBOTRONIK also powers and regulates the magnetic bearing unit. Switching the motor to the generator mode keeps the magnetic bearing unit in operation even in case of a mains power failure.

Both the TURBOTRONIK and the TURBOVAC are fitted with sensors to ensure reliable operation of the entire system. External control and monitoring equipment e.g. the LEYBOTRONIK I can be connected via floating plug-and-socket terminals located at the rear of the TURBOTRONIK. Both the remote control unit and the lines for the pump system's status signals are connected here. These terminals also provide connections for controlling the forepump, the heater and valves.

An RS-232 interface provides a further control and monitoring option.

The unit also has a counter-current braking system for slowing down the pump when it is shut down.

## 1.2 Standard Specifications

### TURBOTRONIK NT 340 M

#### Mains voltage

setting	Cat. No.	for TURBOVAC
230 V	857 29	340 M, MC, 400 MC
120 V	857 30	

#### Standard Specification

Power linecord, Miniature fuses: 2 T 8.0 A; 2 T 4.0 A;  
2 T\* 3.15 A; 2 T1.0 A; 2 T 0.5 A; 2 T 0.315 A  
3 mains plugs, 2 terminal strips,  
1 portable socket-outlet

#### Mains voltage

setting	Cat. No.	for TURBOVAC
100 V	857 31	340 M, MC, 400 MC

#### Standard Specification

Power linecord, Miniature fuses: 2 T 4.0 A;  
2 T 3.15 A; 2 T1.0 A; 2 T 0.5 A; 2 T 0.315 A  
3 mains plugs, 2 terminal strips,  
1 portable socket-outlet

### TURBOTRONIK NT 340 MA

#### Mains voltage

setting	Cat. No.	for TURBOVAC
120 V	857 32	340 M, 340 MC 340 MCT 400 MC, 400 MCT

#### Standard Specification

Power linecord, Miniature fuses: 2 T 8.0 A; 2 T 0.5 A;

### TURBOTRONIK NT 341 MA

#### Mains voltage

setting	Cat. No.	for TURBOVAC
208 V	857 34	341 MCT, 410 MCT

#### Standard Specification

Power linecord (mounted),  
Miniature fuses 4 T 5.0 A, 2 T 0.5 A

Connection lines to the TURBOVAC **do not** belong to the standard specifications.

\*T= slow-blow

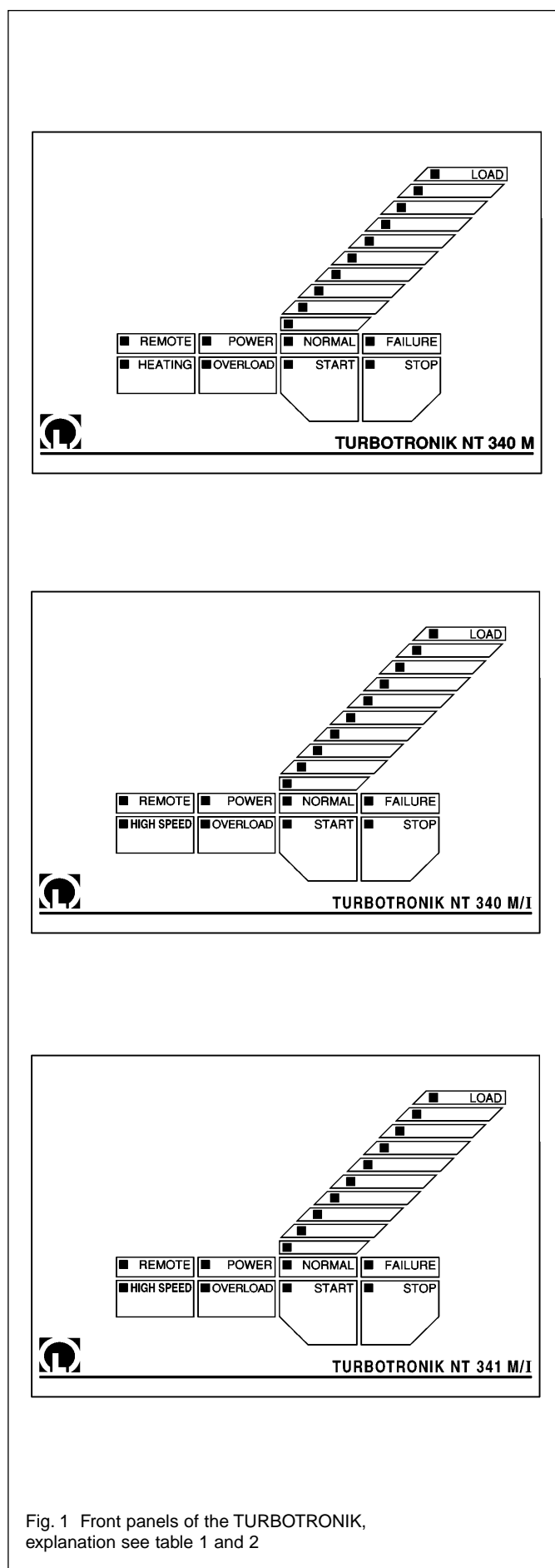

Fig. 1 Front panels of the TURBOTRONIK, explanation see table 1 and 2

**Table 1: Operational Status Display of the Front Panel LEDs**

<b>LED</b>	<b>Color</b>	<b>Display</b>
LOAD (LED chain)	green	LED "START" lights up: speed of the TURBOVAC (individual LED, linear display) LED "STOP" lights up: speed of the TURBOVAC (individual LED, linear display) LED "OVERLOAD" lights up: speed of the TURBOVAC (individual LED, linear display) LED "NORMAL" lights up: motor current (LED chain, logarithmic display) LED "FAILURE" lights up: failure code (one LED "LOAD" flashes)
REMOTE	yellow	Lights up when the converter is controlled via the remote control inputs or via the interface; key manipulation is ignored. Flashes when control is possible both via keyboard and the RS 232 interface.
POWER	green	Lights when mains power supply is on.
NORMAL	green	Lights during normal operation, speed is above 95 % of the target speed Flashes in case of acceleration, braking and "OVERLOAD".
FAILURE	red	Lights in case of failure. Flickers in case of current peaks within the magnetic bearings.
HEATING only on NT 340 M	green	Lights when heating is on. Flashes when heating has been preselected.
HIGH SPEED only on NT 340 MA and NT 341 MA	green	Lights when the TURBOVAC runs with high speed (51,600 min <sup>-1</sup> ).
OVERLOAD	yellow	Lights in case of overload, i. e. speed is below 95 % of the target speed having finished the acceleration sequence.
START	green	Lights in case of TURBOVAC's acceleration. Flashes when the delay start-up time is active.
STOP	green	Lights when the TURBOVAC brakes.

**Table 2: Functions of the Front Panel Keys**

<b>Key</b>	<b>Functions</b>
HEATING only on NT 340 M	Switching the TURBOVAC's heating on and off.
HIGH SPEED only on NT 340 MA and NT 341 MA	Selecting high or optimized speed for TURBOVAC. see Section 3.1.
START	Starting the TURBOVAC's acceleration.
STOP	Braking the TURBOVAC. Resetting a failure report.

## 1.3 Technical Data

Mains voltage, with selector switch	100/120/220/240 V,+10%/-15%
Mains frequency	50/60 Hz
Power consumption including all connected units	<1000 VA
Power consumption of the TURBOVAC	<400 VA
Rated speed of the TURBOVAC	43,860 / 51,600 min <sup>-1</sup>
Minimum speed of the TURBOVAC	6,000 min <sup>-1</sup>
Power output (motor)	
Nominal voltage	50 V
Current limitation	7 A
Power output for the magnetic bearing	
Nominal voltage	± 16 V
Current limitation	± 7 A
<b>Control Inputs</b> - digital, floating	
each terminal	25 V <sub>eff</sub> AC max., 60 V DC versus protective conductor LEYBOTRONIK I compatible
High level; between "+" and "-" terminal	13 V...33 V/max. 10 mA
Low level; between "+" and "-" terminal	0 V...7 V
Pulse duration for remote control active "START" pump, "STOP" pump, heater On/Off	>200 ms
Target speed analog input, not isolated	
Setting range	0...10 V
Rated Speed	0 V
Minimum Speed	10 V
<b>Control Outputs</b>	
Relay for normal operation	25 V <sub>eff</sub> AC, 60 V DC, 2 A/60 W/125 VA operating contact
for acceleration	operating contact
for failure	resting contact, switchable to operating contact
Analog voltage	0...10 V
selectionable speed or motor current proportional	
Loadable	max. 5 mA
Standstill, no current	corresponds to 0 V
Rated speed, max. current	corresponds to 10 V
Reference voltage (not isolated for speed potentiometer and remote control inputs)	15 V, max. 20 mA
Forevacuum pump "FOREPUMP"; Relay point	6 A, 750 VA, 250 V

### Supply Outlets NT 340 M & MA

Voltage value corresponds to mains voltage	
VALVE	max. 20 VA
HEATER	max. 300 VA
FAN	max. 100 VA
For 100 V and 120 V connection: sum of the supply outlets (VALVE, HEATER, FAN)	max. 400 VA

<b>Interface</b>	RS 232/V.24
Connector	25-pin, D-shell, female
Baud rate	4,800 or 9,600

Operating temperature; with sufficient free convection	0-45°C (32°F - 113°F)
Storage temperature	-25°C...+70°C (-77°F - +158°F)

### Interference elimination

ISM appliance group 1, Limit value class A according to EN 50081-2 / EN 55011

### Interference resistance

Electrostatic discharge (ESD) IEC 801-2, VDE 0843, Part 2	Severity 4
Burst IEC 801-4, VDE 0843, Part 4	Level III
high-energy impulse IEC 801-5, VDE 0843, Part 5	Level III

Weight	approx. 7 kg
--------	--------------

### Temperature control unit: supply outlets

Voltage corresponds to mains voltage	
Heating collar "HEATER"	max. 120 W
Cooling water magnetic valve "COOLER"	max. 30 W
Forevacuum valve "VALVE"	max. 120 W

Temperature control unit: fuses	
F1 and F2	T 1.6 A
F3	T 0.315 A

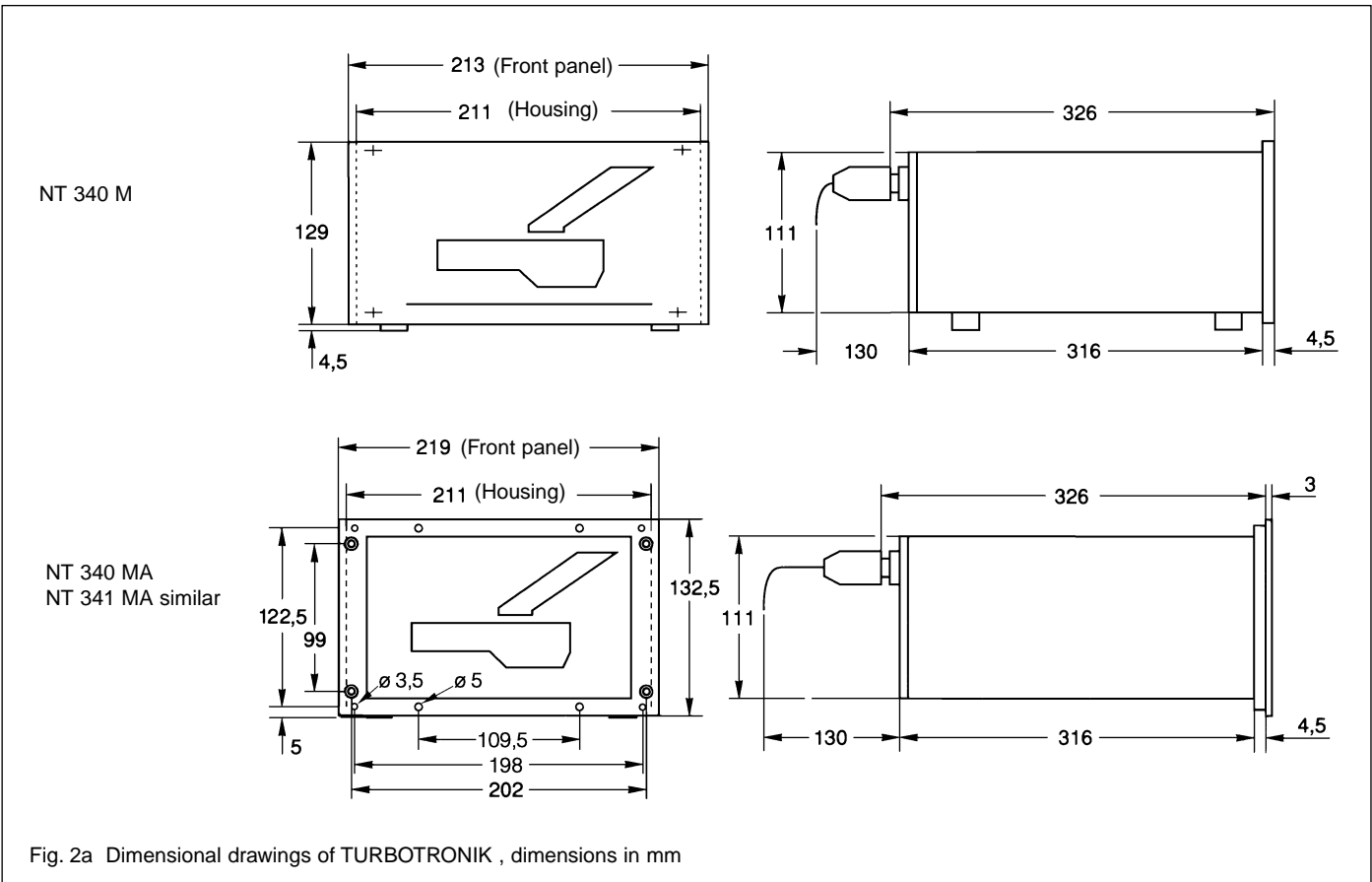

Fig. 2a Dimensional drawings of TURBOTRONIK , dimensions in mm

## 1.4 Ordering Data

	Ref. No.
Pump system control LEYBOTRONIK I	013 10
Power unit for LEYBOTRONIK I	upon request
Delaying venting device	012 44
Venting valve for delaying venting device	012 45

### TURBOTRONIK NT 340 M

Connection line set for connecting the TURBOVAC	
3 m long	857 70
5 m long	857 71
10 m long	857 72
20 m long	857 73

### TURBOTRONIK NT 340 MA

Connection line to the TURBOVAC motor, 3 m long	859 10
Connection line to the TURBOVAC bearing, 3 m long	859 11

### Accessories for temperature control

Temperature control unit (TCU)	859 20
Temperature sensor Pt 100	859 22
Connection lines	
to the heater	859 31
to the cooling water magnet valve (COOLER)	859 32
to the valve	859 33
to the temperature control unit (I/O)	859 34
to the Pt 100	859 39

### TURBOTRONIK NT 341 MA

Connection line to the TURBOVAC motor, 20 m long	859 12
Connection line to the TURBOVAC bearing, 20 m long	859 13

### Accessories for temperature control

Temperature control unit (TCU)	859 21
Temperature sensor Pt 100	859 22
Connection lines	
to the valve	859 33
to the temperature control unit (I/O)	859 34
mains connection line to the temperature control unit	859 35
to the Pt 100	859 36
to the cooling water magnet valve (COOLER)	859 37

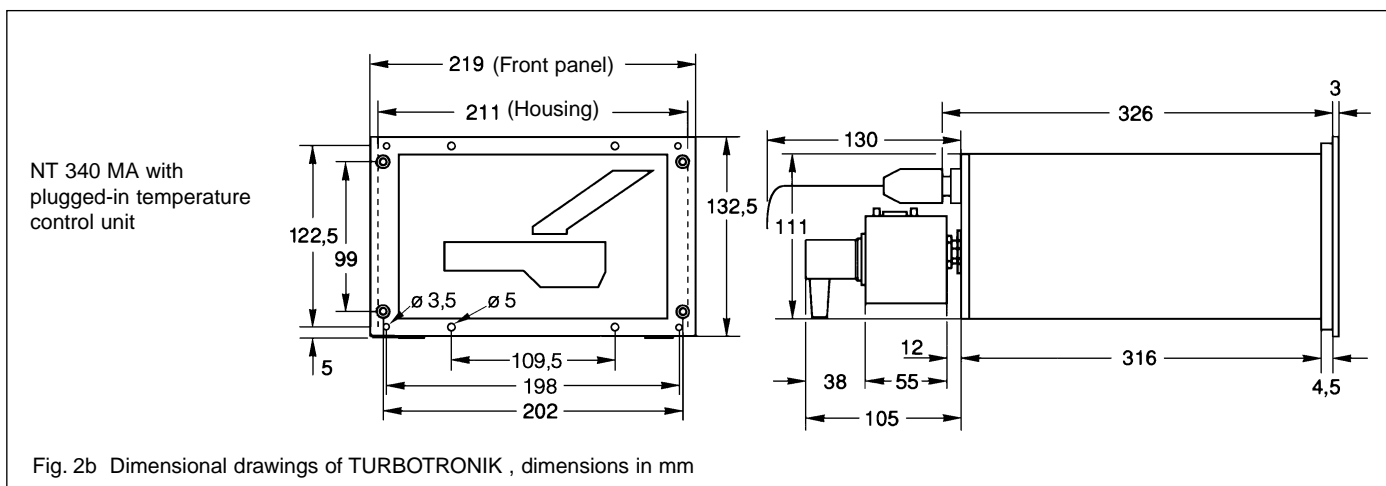

## 2 Connection

### Warning



Connections for forevacuum pump, cooling, venting valve and flange heater must be done by a qualified electrician in accordance with the applicable safety regulations.

### 2.1 Setting the Mains Voltage

The TURBOTRONIK has been set at the factory for a mains power supply; see Section „1.2 Standard Specification“.

To change this setting, remove the dummy plug (3/15) with a screwdriver and reinsert it according to the stamped-on voltage setting. The selected voltage indication must be in the immediate proximity of the arrow.

If you do change the voltage setting, please also change the line power fuse accordingly; see the table.

#### Fuses

	LINE	VALVE	HEATING	FAN
100 V	T*) 4.0 A	T 0.315 A	T 3.15 A	T 1.0 A
120 V	T 8.0 A	T 0.315 A	T 3.15 A	T 1.0 A
220/240 V	T 4.0 A	T 0.315 A	T 3.15 A	T 1.0 A

(\*) slow-blow)

In case of need, other fuses may be installed for VALVE, HEATING and FAN. However, the sum of the fuses' capacity for the three connections must not exceed:

- 4.5 A for 100/120 V
- 6.0 A for 220/240 V.

Plug the power linecord into the socket (3/14), (5/15). The NT 341 MT has a fixed linecord.

### 2.2 Connecting the TURBOVAC

Insert and fasten the connection line to the motor of the TURBOVAC at the socket DRIVE and to the TURBOVAC itself.

Insert and fasten the connection line to the stabilizer and axial sensor of the TURBOVAC at the socket BEARING and to the TURBOVAC itself; both plugs are non-interchangeable.

### 2.3 Connecting the Forevacuum Pump

Connect the forepump to the relay contact output FORE-PUMP. When pressing the START key the contact is closed without any delay and the forepump is switched on.

The forepump is shut down when the TURBOVAC has come to a standstill, switching examples see fig. 11.

A starting delay for the TURBOVAC can be set at the potentiometer DELAY; see Section 3.1

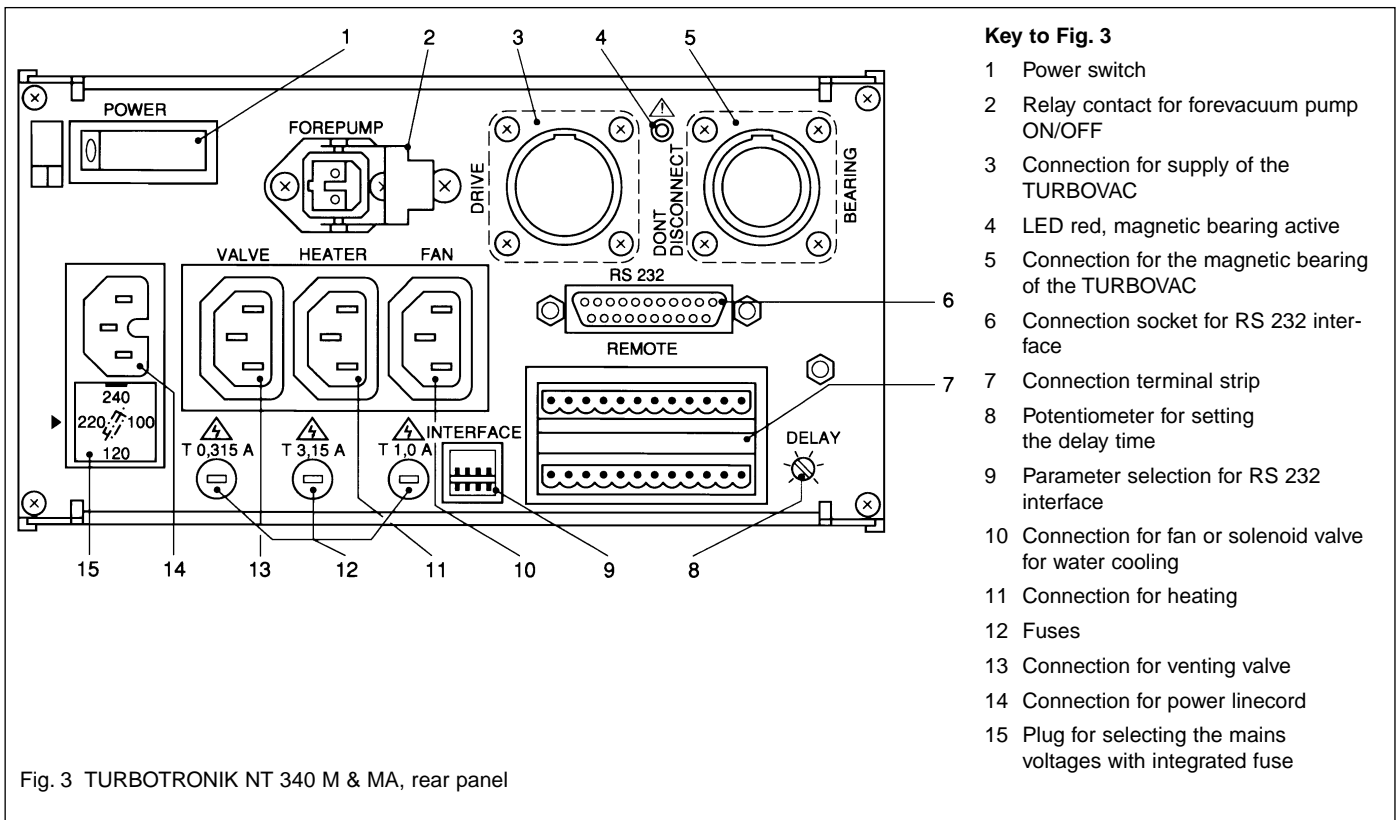

## 2.4 NT 340 M & NT 340 MA without temperature control: Connecting the Cooling, Venting Device and the Flange Heater

### Cooling

The mains power supply to the socket (3/10) is switched on as soon as the TURBOVAC acceleration sequence begins; max. load 100 VA. The relevant fuse (3/12) is below the socket.

The power supply to the socket is switched off once the TURBOVAC has come to a standstill and when the power switch is turned off.

A magnetic valve for the water cooling or a fan can be connected to the socket (3/10).

### Venting

The mains power supply to the socket (3/13) is switched on without any delay when START is activated. The power is turned off when STOP or FAILURE are activated; max. load 20 VA. The relevant fuse (3/12) is below the socket.

### Caution

Any interruption in power, no matter how short, will cause the pump to be vented.

### Power Failure Airing Valve

If the TURBOVAC is operated without purge gas a power failure airing valve can be connected to socket (3/13) VALVE.

### Purge Gas- and Venting Valve

When operating the TURBOVAC with purge gas it must be vented via the purge gas and venting valve.

### Delayed Venting Device and Venting Valve

When shutting down or in case of a power failure the connection of the delayed venting device allows for setting the start and duration of the venting sequence in order to protect a system or a process-procedure.

The presetting time can vary between 3 to 15 minutes.

A short power failure does not entail an unwanted venting.

Connect the delayed venting device to (3/13).



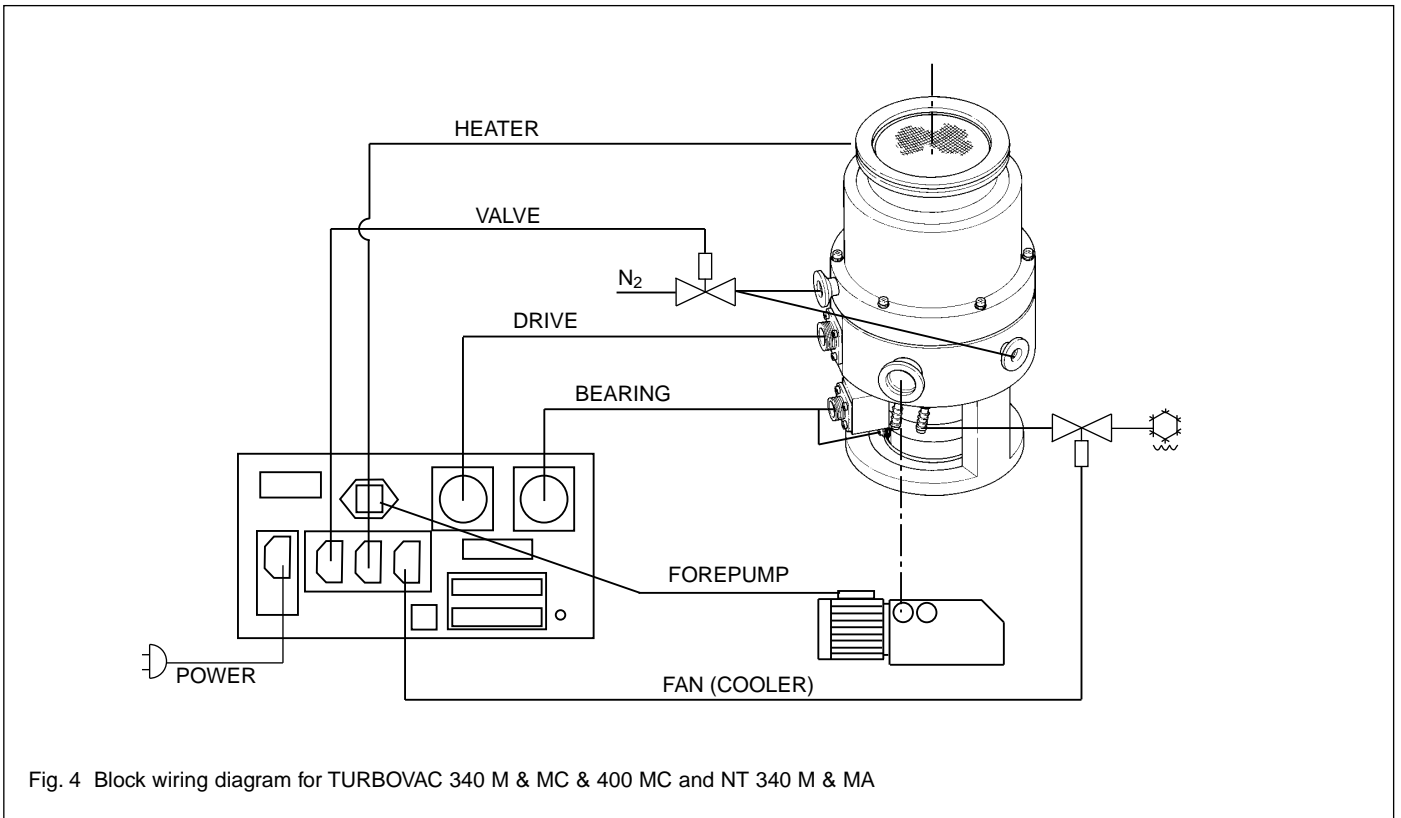

Fig. 4 Block wiring diagram for TURBOVAC 340 M & MC & 400 MC and NT 340 M & MA

**Flange Heater**

(Only for pumps with CF connection flange)

The mains power supply to the socket (3/11) is switched on when HEATING is activated, provided that the pump operation status is NORMAL; max load 300 VA.

The relevant fuse (3/12) is below the socket.

Connect the flange heater to the TURBOVAC at socket (3/11) "HEATER".

**Key to fig. 5**

- 1 Power switch
- 2 Relay contact for forevacuum pump ON/OFF
- 3 Connection for supply of the TURBOVAC
- 4 LED red, magnetic bearing active
- 5 Connection for the magnetic bearing of the TURBOVAC
- 6 Connection socket for RS 232 interface
- 7 Connection terminal strip
- 8 Potentiometer for setting the delay time
- 9 Parameter selection for RS 232 interface
- 10 Connection for voltage supply of the temperature controller
- 11 Connection for cooling water magnetic valve
- 12 Connection for heating collar
- 13 Connection for forevacuum valve
- 14 Connection for Pt 100
- 15 Connection of the power linecord

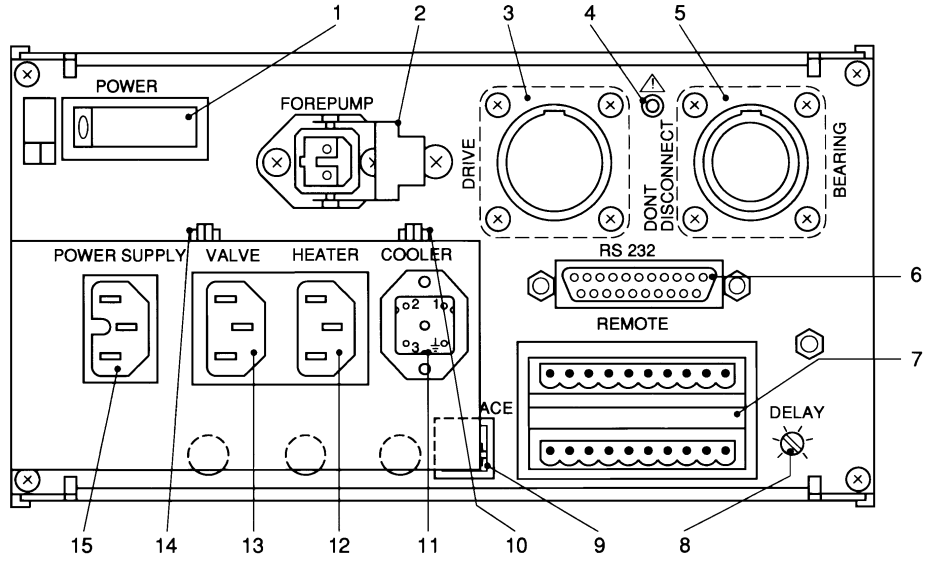
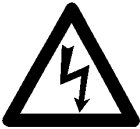

Fig. 5 TURBOTRONIK NT 340 MA with temperature control unit, rear panel

**Warning**



Prior to opening the temperature control unit pull it off. If the plug of the temperature control unit is connected there may be line voltage inside the unit.

Fig. 6 Location of the fuses F1, F2, F3 in the temperature control unit; bottom removed

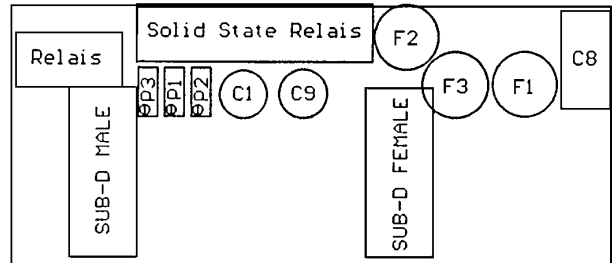

**Table 3: Temperature Control Unit: Pin assignment of the Sub D Sockets**

<b>Sub D Socket VOLTAGE I/O (Plug)</b>		<b>Sub D Socket Pt 100 (Socket)</b>
Pin 1	Relay contact*	Linked with pin 2
Pin 2	Voltage of the Pt 100 (0.1 V corresponds to 1 °C)	Pt 100
Pin 3	Common point for the relay*	Pt 100
Pin 4	Voltage threshold „NORMAL“	Linked with pin 3
Pin 5	Relay contact*	Linked with pin 3
Pin 6	Earthed (of NT: pin 21 of the socket REMOTE)	Linked with pin 2
Pin 7	Voltage threshold „Pump too cold“	Linked with pin 3
Pin 8	Voltage threshold „Pump too hot“	Linked with pin 3
Pin 9	+ 15 V (of NT: pin 210 of the socket REMOTE) Voltage supply for temperature controller	Linked with pin 3

\* If the pump is too hot or too cold (FAILURE), the contact between pin 1 and 3 is closed and open between pin 3 and 5.

In the operation mode NORMAL of the temperature controller the contact between pin 1 and 3 is open and closed between pin 3 and 5.

Too hot:  $T > 75\text{ °C}$  (167°F); too cold:  $T < 55\text{ °C}$  (131°F); NORMAL:  $55\text{ °C} \leq T \leq 75\text{ °C}$  (131°F  $\leq T \leq$  167°F)

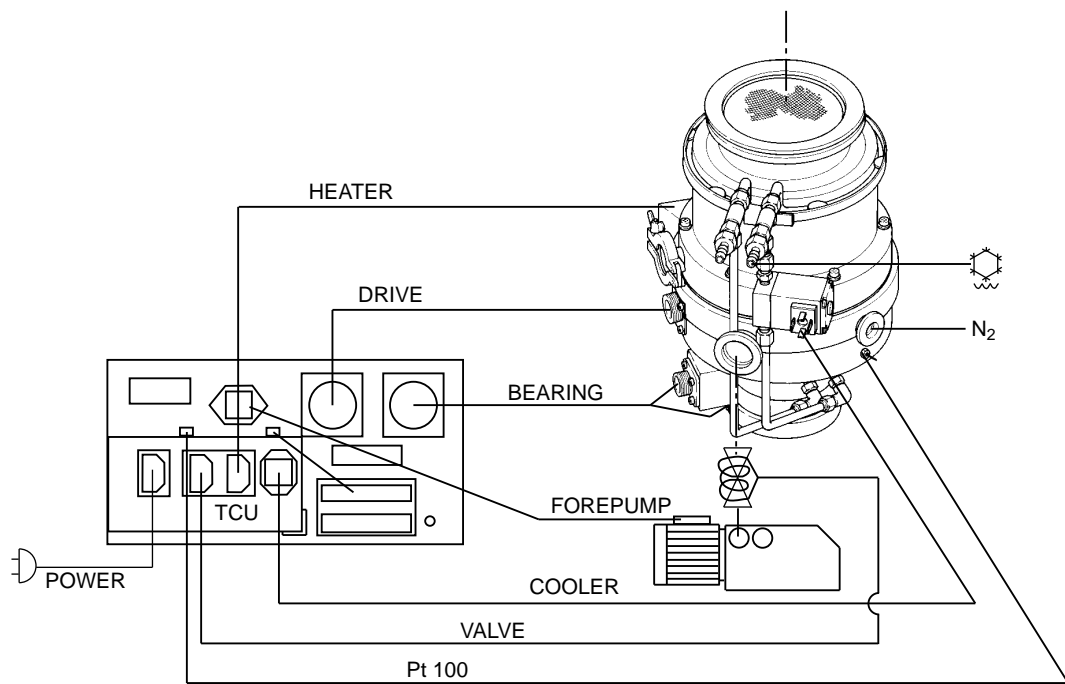

Fig. 7 Block wiring diagram for TURBOVAC 340 MCT & 400 MCT and NT 340 MA with temperature control

## 2.5 NT 340 MA with temperature control: Connecting the Temperature Control and the Forevacuum Valve

### Temperature control

The parts required for temperature control are listed in Section 1.4.

Plug in the temperature control unit, see Fig. 5.

The temperature control controls the temperature of the TURBOVAC 340 MCT & 400 MCT within a narrow control range.

Connect the connection line to the heating collar at the heating collar of the TURBOVAC and at the socket HEATER.

Plug in the connection line to the cooling water magnetic valve at the cooling water magnetic valve of the TURBOVAC and at the socket COOLER.

Plug the connection line of the Pt 100 of the TURBOVAC into the socket Pt 100.

Plug in the connection line temperature control unit - TURBOTRONIK at the sockets VOLTAGE I/O and REMOTE.

### Forevacuum valve

The socket VALVE is supplied with current provided the mains voltage is applied, max. rate: 120 W.

A heater for a forevacuum valve can be connected to the socket.

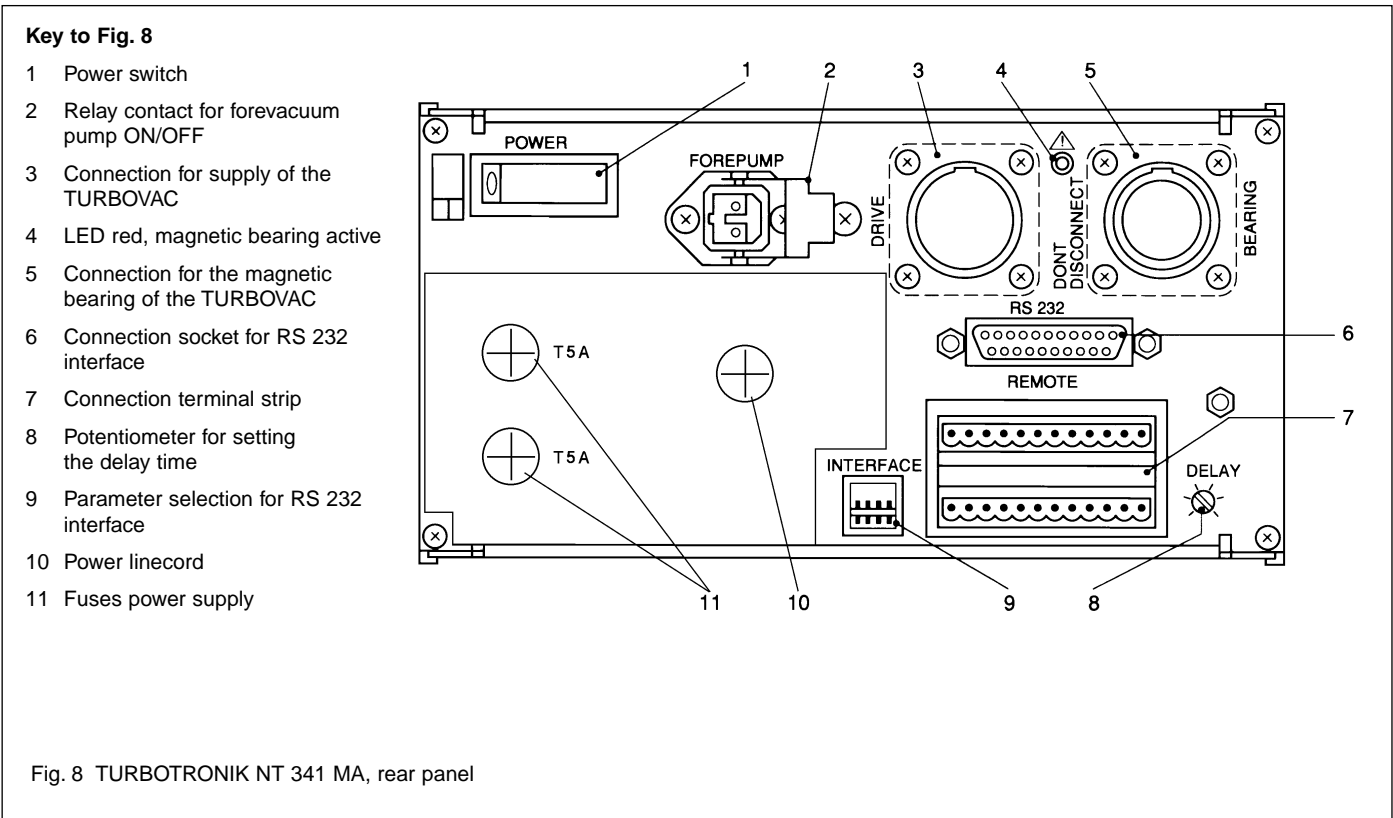

Fig. 8 TURBOTRONIK NT 341 MA, rear panel

## 2.6 NT 341 MA: Connecting the Temperature Control and the Forevacuum Valve

### Temperature control

The parts required for temperature control are listed in Section 1.4.

Install the temperature control unit.

The temperature control controls the temperature of the TURBOVAC 341 MCT & 410 MCT within a narrow control range.

The temperature control unit has to be connected to 120 V AC mains voltage.

### Warning



The power supply must ensure that even in case of failure no lethal voltages may occur.

Connect the connection line of the heating collar at the socket HEATER.

Plug in the connection line to the cooling water magnetic valve at the cooling water magnetic valve of the TURBOVAC and at the socket COOLER.

Plug the connection line of the Pt 100 of the TURBOVAC into the socket Pt100.

Plug in the connection line temperature control unit - TURBOTRONIK at the sockets VOLTAGE I/O and REMOTE.

### Forevacuum valve

The socket VALVE is supplied with current provided the mains voltage is applied, max. rate: 120 W.

A heater for a forevacuum valve can be connected to the socket.

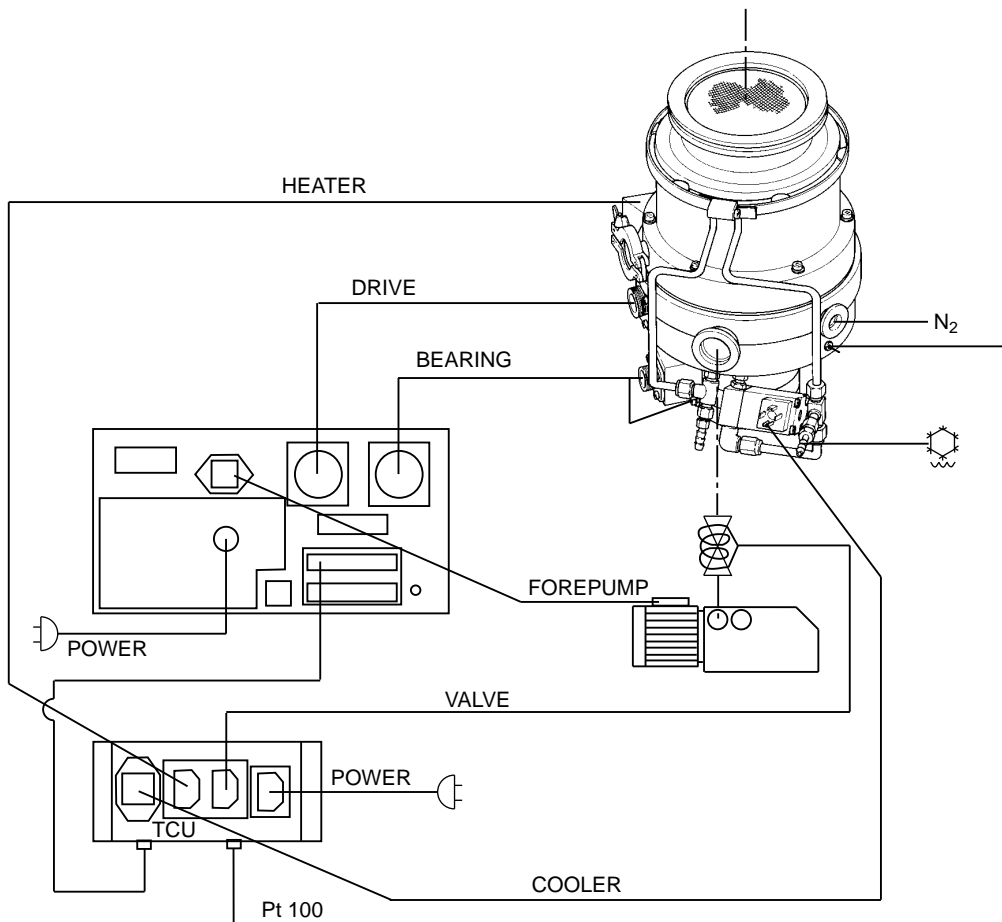

Fig. 9 Block wiring diagram for TURBOVAC 341 MCT & 410 MCT and NT 341 MA with temperature control

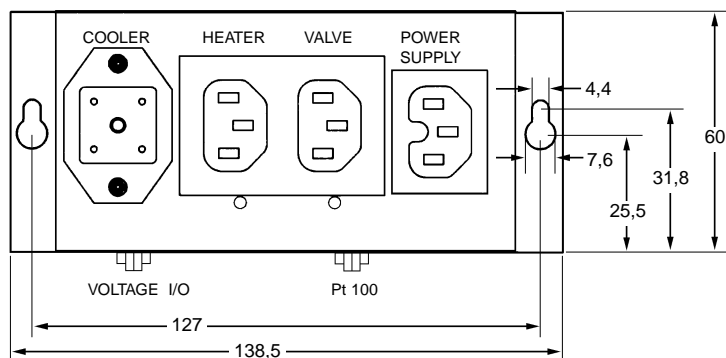

Fig. 10 Temperature Control Unit, dimensions in mm

## 2.7 Connecting the Interface

A description of the interface for operating the TURBOTRONIK with a computer can be ordered under the description SB 05.207.

The parameters for the interface will be set at the DIP switches.

At DIP switch 1 you can choose whether the analog output voltage at the terminal strip REMOTE will rise proportionally to the motor current or the speed.

ON analog output = motor current LOAD.

OFF analog output = SPEED.

## 2.8 Connecting the Remote Control Unit

For the signal assignments of the terminal strip REMOTE refer to fig. 12.

Switching examples see fig. 13.

Technical Data see section 1.3.

Relay statuses see table 4.

### Note for Switching Example ON/OFF Switch

If instead of the ON-OFF switch a jumper is established between Pin 4 and 20, the TURBOVAC will start up automatically once the TURBOTRONIK is switched on.

### Caution

The maximum permissible voltage at each of the terminals is 25 Veff AC, 60 V DC versus protective conductor.

### Inputs - Remote control active

REMOTE	Disables the keys and activates the remote control inputs (continuous signal; High-active)
START pump	Impulse or continuous signal; High-active
STOP pump	Impulse or continuous signal; Low-active
HEATING	Heating ON/OFF steady-state signal; High = On, Low = Off
Speed (target value)	analog signal

Due to safety reasons the STOP function (Low-active) is dominant.

In order to start the TURBOTRONIK via the remote control:

the REMOTE-inputs must be activated i.e. high-level between "+" and "-" terminal,

the STOP-inputs must be inactivated i.e. high-level between "+" and "-" terminal,

the START-inputs must be activated i.e. high-level between "+" and "-" terminal.

### Outputs

Acceleration,

Normal operation,

Failure,

Current-/speed actual value,

The reference voltage is +15 V for speed potentiometer and remote control inputs.

The reference voltage is protected by the fuse F7. Position of the fuse see fig. 14. For changing the fuse open the TURBOTRONIK as described in section 2.9.

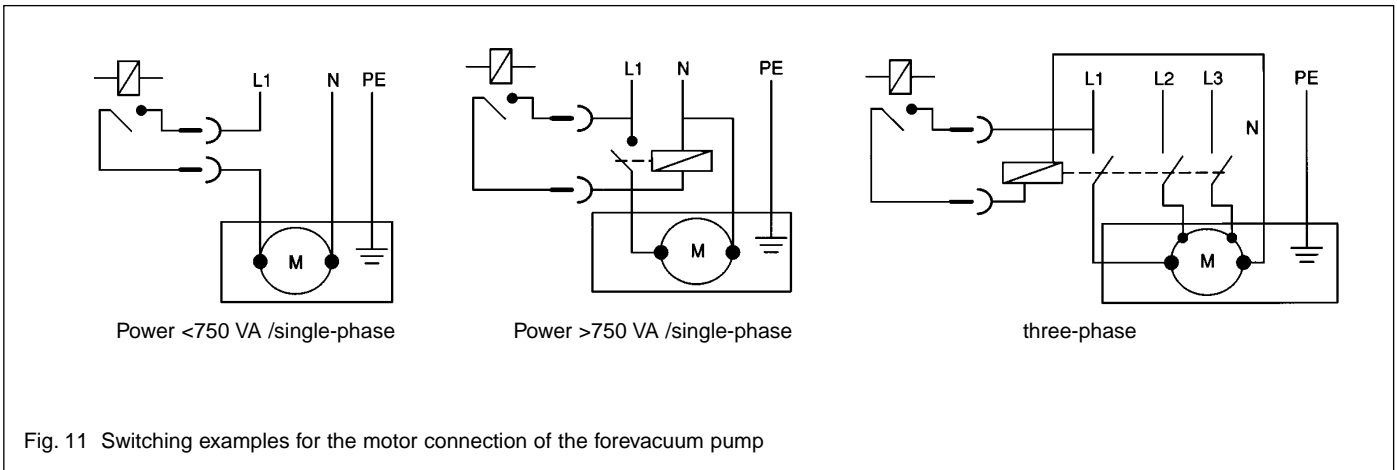

Fig. 11 Switching examples for the motor connection of the forevacuum pump

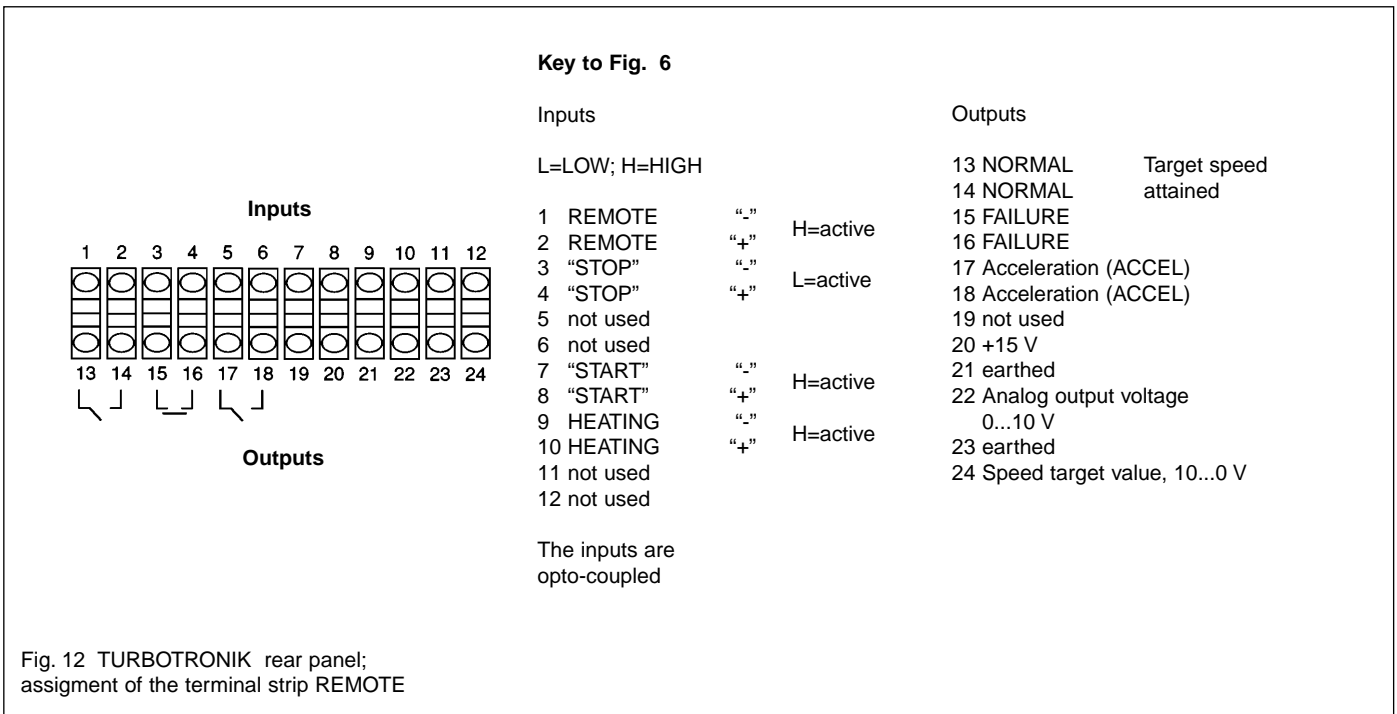

Fig. 12 TURBOTRONIK rear panel; assignment of the terminal strip REMOTE

**Table 4**

Relay status	VALVE (3/13)	HEATER (3/11)	FAN (3/10)	FOREPUMP (3/2)	ACCEL Fig. 12	FAILURE Fig. 12	NORMAL Fig. 12
Power off	open	open	open	open	open	closed**	open
Standstill	open	open	open	open	open	closed**	open
Delayed start-up device	closed	open	open	closed	closed	closed**	open
Acceleration	closed	open	closed	closed	closed	closed**	open
NORMAL	closed	closed*	closed	closed	open	closed**	closed
Overload	closed	closed*	closed	closed	open	closed**	closed
Braking	open	open	closed	closed	open	closed**	open
Failure; TURBOVAC rotates	open	open	closed	closed	open	open**	open
Failure; TURBOVAC stands still	open	open	open	open	open	open**	open

\* if selected    \*\* modifications possible





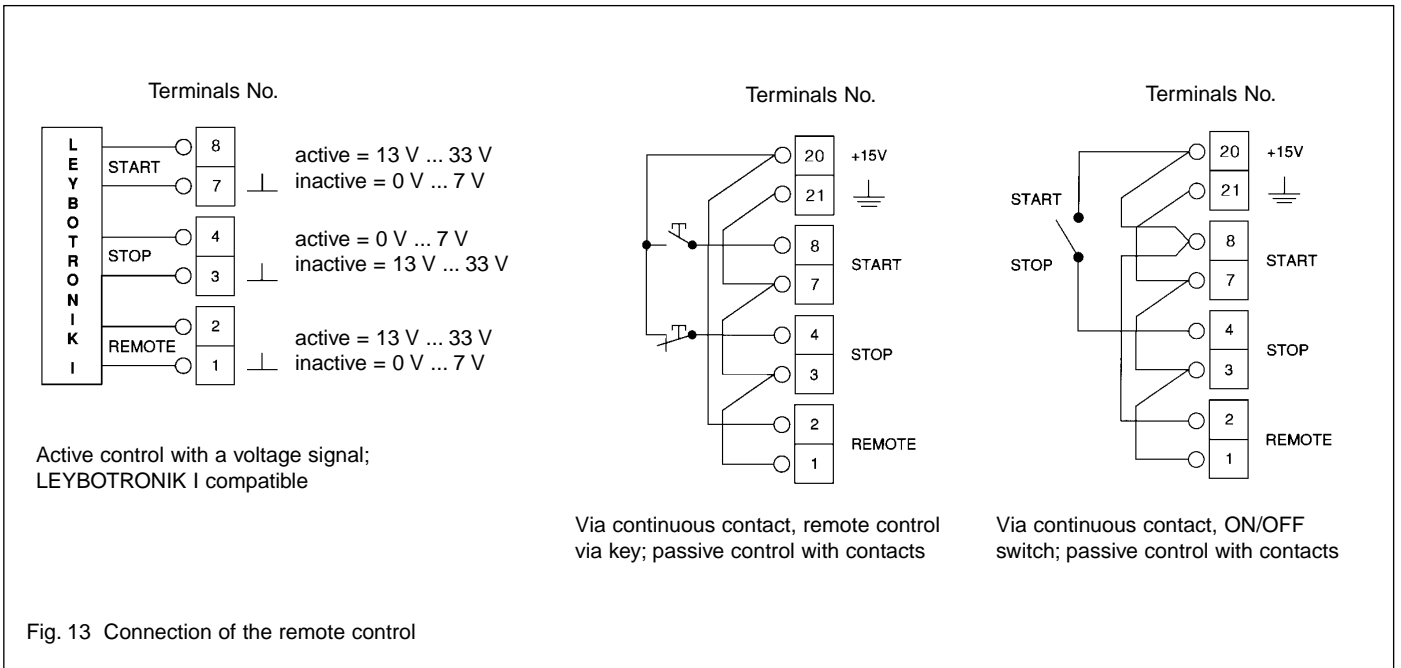

Fig. 13 Connection of the remote control

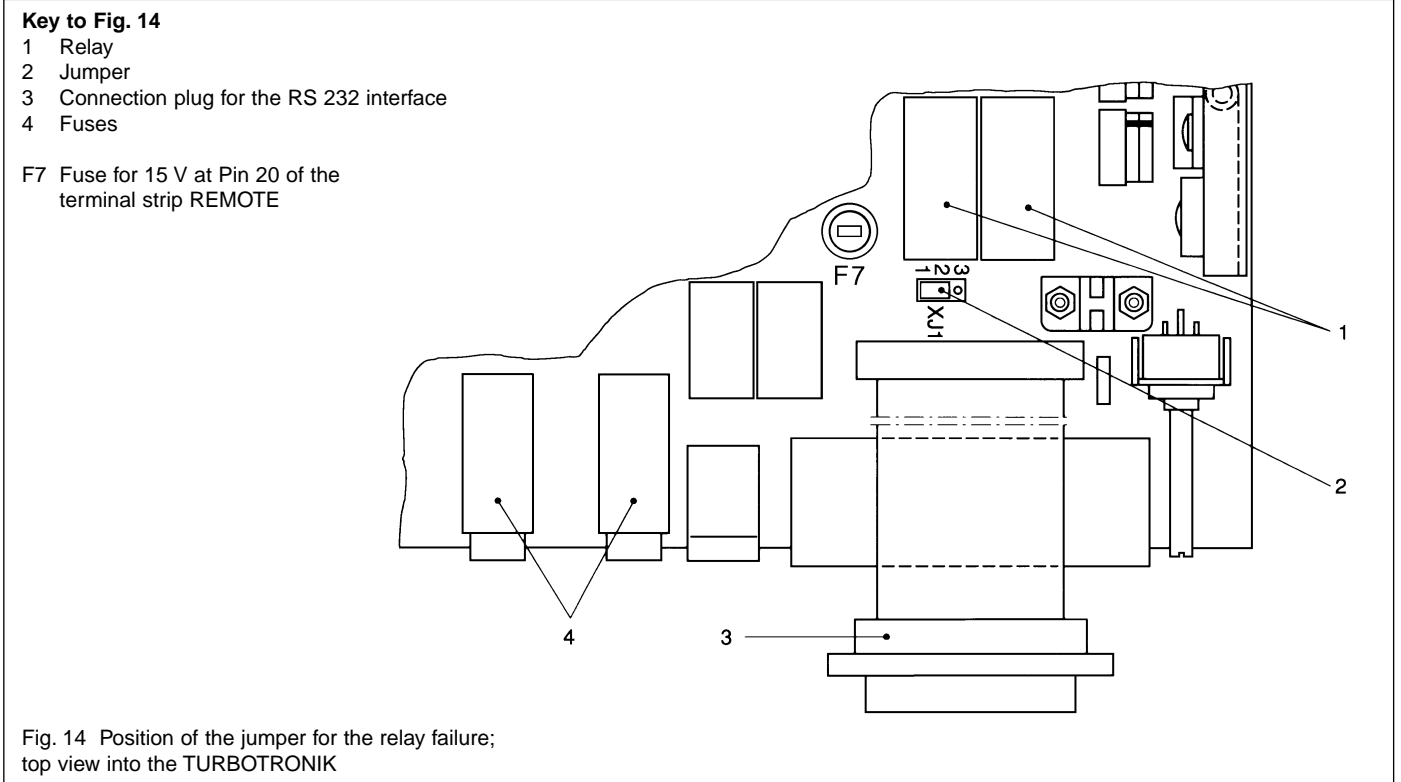

Fig. 14 Position of the jumper for the relay failure; top view into the TURBOTRONIK

## 3 Operation

### 3.1 Start-up

Insert the power plug.

Switch on the POWER switch.

Having switched on the power switch the TURBOVAC's stabilizer is activated and the rotor lifts up.

Afterwards all LEDs light up for approx. 2 s for a functional check. The green LED „POWER“ remains on.

On the TURBOTRONIK NT 340 MA and 341 MA with temperature control the temperature control is switched on.

It is not necessary to check or to recalibrate the rotor position control system.

#### **Setting the Start-up Delay**

You can set a start-up delay for the TURBOVAC of up to five minutes at the rear of the TURBOTRONIC at DELAY.

Due to the starting delay the TURBOVAC starts after the forevacuum pump.

#### **Selecting high or optimized speed (only on NT 340 MA & NT 341 MA)**

The TURBOVAC is designed for operation with optimized speed.

In certain cases the standard speed which is set on delivery, can be increased (HIGH SPEED). Please contact your local Leybold service representative.

#### **Caution**

HIGH SPEED operation may result in shorter operational lifetime of the pump. Your warranty may be voided.

### 3.2 Start-up of the TURBOVAC

Pressing the START key initiates the acceleration sequence; if a forevacuum pump is connected it will start up immediately.

If a delay has been set, the START LED will flash during the delay period, after which it will remain on continuously and the TURBOVAC starts.

The NORMAL LED flashes during acceleration. The LED chain indicates the increasing speed with one LED each. When 95% of the target speed has been reached, the LED NORMAL remains on continuously, the START LED extinguishes.

During normal operation the LED chain indicates the course of the increasing motor power consumption; the increasing current (load) drawn by the TURBOVAC is indicated by the LED chain with one LED each lighting up after the other starting at the bottom and moving upwards.

If the TURBOVAC exceeds the minimum speed within 8 minutes but does not attain 95 % of the target speed it will change to OVERLOAD operation.

The LED OVERLOAD lights up and the LED chain indicates the speed.

### 3.3 Bake-out of the TURBOVAC

#### **(only for NT 340 M)**

Bake-out is only possible with the CF version during NORMAL operation.

Pressing the HEATING key switches the flange heater ON and OFF. The green LED in the key lights up when the heating is ON.

With preselection the LED flashes during the acceleration phase; during NORMAL and activated heating the LED lights continuously.

### 3.4 Operation

During normal operation the TURBOVAC runs with target speed. The LED NORMAL lights and the LED chain shows - starting at the bottom and moving upwards - the current consumed.

In case of increased load (e.g. increased pressure due to a leak) the speed is compensated via an additional current consumption. Thus, the number of the lighting LEDs is a measure of the pressure rise.

A further pressure rise beyond the point of the max. current limitation leads to a decreasing speed due to an increasing gas friction.

The speed will likewise drop when the temperature of the TURBOVAC or TURBOTRONIK is too high, the LED OVERLOAD lights up.

If the target speed drops below 95% the LED chain indicates the speed. The LED NORMAL flashes.

If the speed drops below the minimum speed, the TURBOVAC is switched off and the LED FAILURE lights up.

### 3.5 Shut-down of the TURBOVAC

Pressing the STOP key switches off the pump and the heater and activates braking.

The forevacuum pump will be switched off provided it is connected via FOREPUMP; the TURBOVAC will be vented if the venting valve is connected via (3/13).

The LED in the STOP key lights up, and the LED NORMAL flashes until the TURBOVAC stands still.

The motor brakes the pump actively until it comes to a complete standstill; the speed is again indicated by the LED chain.

If a malfunction occurs the FAILURE signal can be reset via the STOP key provided the cause of malfunction has been eliminated and the rotor of the TURBOVAC stands still.

### 3.6 Venting of the TURBOVAC

Vent the TURBOVAC every time the TURBOVAC is switched off in order to prevent a potential backstreaming of oil vapors from the forevacuum line to the high-vacuum side.

If a power failure airing valve or a delayed venting device is connected to the socket (3/13) VALVE the TURBOTRONIK controls venting automatically.

### 3.7 Power Failure - Linecord Interruption

If there is a power failure or if the power plug is accidentally disconnected, the TURBOTRONIK automatically switches over the drive of the TURBOVAC to generator operation. This means that during run-down of the pump, the active magnetic bearing regulation will be maintained until the rotor sets down on the touch-down bearings with the rate of rotation being low.

If the connecting lines between the TURBOVAC and the TURBOTRONIK are interrupted, the automatic generator operation and the emergency power supply to the active magnetic bearing are put out of operation. In this case, the rotor is set down immediately onto the touch-down bearings, runs down with a considerable noise level and there is a risk that the touch-down bearings are damaged.

The connection line to the TURBOTRONIK is secured against accidental interruption. If it is, nevertheless, interrupted e. g. by mechanical destruction, brake the TURBOVAC via venting until it stands still.

## **3.8 Shutdown of the TURBOTRONIK**

Press the STOP key, and wait until the pump comes to a standstill.

The LEDs in the keys START, STOP and NORMAL are extinguished.

Switch the POWER switch to the "0" position. The temperature control at the TURBOTRONIK NT 340 MA and NT 341 MA with temperature control is switched off.

If the red LED DON'T DISCONNECT has gone off the connection lines to the TURBOVAC can be disconnected in case of necessity.

### **Caution**

Only after the pump has come to a standstill is the POWER switch to be switched to the "0" position.

In case of accidental shutdown, start up the pump at once.

## **3.9 Maintenance**

The TURBOTRONIK is maintenance-free.

# 4 Troubleshooting

When a malfunction occurs, the TURBOVAC is braked and the failure is indicated; see following table.

The red LED FAILURE lights permanently and one green LED within the chain flashes.

When the pump is at a complete standstill, and after you have eliminated the cause of the failure, you can reset the malfunction signal with the STOP command (key or remote control).

## Warning



Before you open the TURBOTRONIK, please first ensure that the TURBOVAC has been braked to a complete standstill, and that the mains power cord is disconnected. Since, nonetheless dangerous voltages may occur the unit must only be opened by a qualified electrician.

LED flashes	Symptom	Probable Cause	Recommended Corrective Action
<b>No. 1</b> (below)	Linecord fault.	Motor connection line incorrectly connected.	Check the motor connection line and connect it correctly.
		Motor connection line malfunctioning.	Replace the motor connection line.
<b>No. 2</b>	TURBOVAC is not supported by the TURBOTRONIK.	TURBOTRONIK and TURBOVAC incompatible. Loose contact in connection line.	Check the system. Repair the connection lines.
<b>No. 3</b>	Not used		
<b>No. 4</b>	Speed below minimum or has not been attained during acceleration within 8 minutes.	Forevacuum pressure $>10^{-2}$ mbar. Pump blocked. High-vacuum pressure too high.	Check the forevacuum. Inform the Leybold after-sales service. Check the vacuum chamber.
<b>No. 5</b>	Temperature in the TURBOTRONIK too high.	Frequent switching between acceleration and braking.	Let the TURBOTRONIK cool down.
		Ambient temperature too high. Forevacuum pressure $>10^{-2}$ mbar.	Ensure an adequate ventilation. Operate the pump under normal load only.
<b>No. 6</b>	Temperature in the TURBOVAC too high.	Frequent switching between acceleration and braking. Poor cooling or cooling line interrupted.	Let the pump cool down and operate under normal load only. Check the cooling.
<b>No. 7</b>	Self test.	Mains malfunction. EPROM malfunctioning.	Switch the mains off and then again on. Inform the Leybold after-sales service.
<b>No. 8</b>	Bearing malfunctioning.	Venting curve not observed. Pump incorrectly adjusted. Pump or pump system vibration. Excess temperature in the TURBOTRONIK. Touch-down bearings worn. RF interference.	Check the system. Control the bearings. Set up the pump system more quietly. Operate the pump under normal load only. Inform the Leybold after-sales service. Ground the TURBOTRONIK, locate the AC power cord in a separate bundle from the RF source, change the location of the TURBOTRONIK, if needed.
<b>No. 9</b>	Not used.		

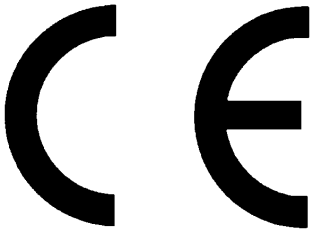

## EC Conformance Declaration



We, the Leybold Vacuum GmbH, declare herewith that the products listed below, on the basis of their design and engineering as well as in the embodiment which we have placed on the market, comply with the applicable safety and health requirements set forth in EC guidelines.

This declaration becomes invalid if modifications are made to the product without consultation with us.

Designation of the product:

Electronic frequency converter

Models: TURBOTRONIK NT 340 M  
NT 340 MA  
NT 341 MA

Catalog numbers: 857 29/30/31  
857 32  
857 34

Cologne, July 5, 1996

Mr. Beeck, Instruments Division Manager

### **The products comply with the following guidelines:**

- EC Low-Voltage Guidelines (73/23/EEC)
- EEC Directive on Elektromagnetic Compatibility (89/336/EWG), measured with a typical test configuration

### **Applicable, harmonized standards:**

- EN 61010-1: 1993
- EN 50081-2: 1992
- prEN 50082-2: 1992

### **Applied national standards and technical specifications:**

- VDE 0411 Part 1/03.94
- VDE 0839 Part 81-2/03.93
- EVDE 0839 Part 82-2/01.93

Cologne, July 5, 1996

Mr. Finke, Instruments Development



### **LEYBOLD VAKUUM GmbH**

Bonner Strasse 498 (Bayenthal)  
D-50968 Cologne

Tel.: + 49 (221) 347-0

Fax: + 49 (221) 347-1250

<http://www.leyboldvac.de>

e-mail: [documentation@leyboldvac.de](mailto:documentation@leyboldvac.de)