

Vacuum Solutions

Application Support

Service



LEYBOLD VACUUM

GA05118_1302

PTB
SALES

FOR SALES AND SERVICE PLEASE CALL:
PTB SALES T :: 866.332.0500
F :: 626.334.2151
www.ptbsales.com

DATE SERVICED: _____

VIEW OUR INVENTORY



TURBOVAC

Turbomolecular pumps with grease-lubricated bearings

Operating instructions

Contents

	Page
1 Description	2
Compatibility with pumped media	2
1.1 Standard equipment	3
1.2 Order data	3
1.3 Technical data	4
2 Connections	8
2.1 Operating environment	9
2.2 Connecting the pump to the vacuum chamber	9
2.3 Making the forevacuum connection	12
2.4 Connecting the cooling	12
2.5 Connecting the purge gas and airing device	12
2.6 Connecting the TURBOTRONIK	13
3 Operation	14
3.1 Switching on	14
3.2 Bakeout	14
3.3 Operation	14
3.4 Switching off	15
3.5 Venting	15
3.6 Removing the pump from the system	16
4 Maintenance	17
4.1 Cleaning	17
4.2 Service by LEYBOLD	17
5 Troubleshooting	18
EC Manufacturer's Declaration	19

Conventions used in these instructions

Illustrations

The references to diagrams, e.g. (2/10), consist of the figure number and the item number, in that order.

Warning

This indicates procedures and operations which must be strictly observed to prevent hazards to persons.

Caution

This indicates procedures and operations which must be strictly observed to prevent damage to or destruction of the unit.

We reserve the right to change at any time the design and data given in these operating instructions.

The illustrations are approximate.

1 Description

The TURBOVAC models 50 to 1000 are turbomolecular pumps featuring grease-lubricated bearings. These units are engineered to pump vacuum chambers down to pressures in the high-vacuum range. A TURBOTRONIK frequency converter and a forevacuum pump are required for the operation of the TURBOVAC.

These units are **not** suitable for operation without a forevacuum pump.

Compatibility with pumped media

Turbomolecular pumps are **not** suitable for pumping either gases which contain dust particles or liquids.

Turbomolecular pumps without a purge gas feature are suitable only for moving air or inert gases. They are not suitable for pumping aggressive or reactive gases.

TURBOVAC versions identified with a "C" in the model number are equipped with this purge gas feature, it protects only the bearing area and the motor in the TURBOVAC.

Some media (such as aluminum trichloride) can sublime inside the pump and form deposits. Thick deposits reduce the play between moving parts to the point that the pump could seize. In some processes deposits can be prevented by heating the pump. Please consult with us in case such problems arise.

Corrosive gases (such as chlorine) can destroy the rotors.

During operation the pressure inside the TURBOVAC is so low that there is no danger of ignition (at pressures below about 100 mbar, 75 Torr). A hazardous condition will be created if flammable mixtures enter the hot pump at pressures above 100 mbar (75 Torr). During operation the pump can reach temperatures as high as 120°C (248 °F). Sparks could occur in case of damage to the pump and these could ignite explosive mixtures.

We would be glad to consult with you as regards the media which can safely be handled with this unit.

Warning



Never expose any parts of the body to the vacuum.

Caution

Any tampering within the pump or modifications to the mechanical or electrical components of the pump, will void any liability and warranty claims.

1.1 Standard equipment

The TURBOVAC is shipped in a sealed PE bag which also contains a desiccant.

The maximum effective life of the desiccant is one year.

for high-vacuum port with ISO-K flange:

Splinter guard,
Centering ring with FPM sealing ring; outer ring.

for high-vacuum port with CF flange:

Splinter guard.

for high-vacuum port with KF flange:

Splinter guard, centering ring with FPM O-ring and clamping ring.

for high-vacuum port with ANSI flange:

Splinter guard.

Forevacuum port

Centering ring with O-ring and clamping ring.

Both the purge gas port and the airing port are blanked off for shipping.

In addition the pivoted threaded fittings used to make the coolant connection are included as standard equipment for the TURBOVAC 151, 361 and 600; if needed, they can be used to replace the hose nipples installed at the factory.

The electronic frequency converter and the connector cables required for operation are not included as standard equipment with the pump.

PE = Polyethylene

FPM = Fluoroelastomer, resistant to temperatures of up to 150°C (300 °F)

1.2 Order data

TURBOVAC	50	50 D2	151	151 C	361	361 C	600 C	1000 C
High-vacuum flange								
DN 40 KF	854 00							
DN 40 CF	853 99							
DN 63 ISO-K	854 01 800150V0010	856 68						
DN 63 CF	854 02							
DN 100 ISO-K			856 31	856 35	856 70	856 75		
DN 100 CF			856 32		856 71			
DN 160 ISO-K					856 72	856 77	856 82	855 35 ¹⁾ 855 38 ²⁾
DN 160 CF					856 73		On request	On request
DN 200 CF								On request
6" ANSI							894 25	894 89 ¹⁾
DN 250 ISO-K								855 36 ¹⁾ 855 39 ²⁾

1) With forevacuum flange DN 40 KF

2) With forevacuum flange DN 63 ISO-K

1.3 Technical data

TURBOVAC		50	50	50	50	50 D2
High-vacuum port	nom.diam.	40 KF	40 CF	63 ISO-K	63 CF	63 ISO-K
Pumping speed for N ₂	l/sec	33	33	55	55	55
Ultimate pressure	mbar	8·10 ⁻⁹	< 10 ⁻⁹	8·10 ⁻⁹	< 10 ⁻⁹	< 10 ⁻⁹
Forevacuum pressure, max. N ₂	mbar	0.5	0.5	0.5	0.5	15
Recommended fore-vacuum pump	TRIVAC	D 2.5 E	D 2.5 E	D 2.5 E	D 2.5 E	Diaphragm pump
Recommended frequency converter	NT	10/12/13	10/12/13	10/12/13	10/12/13	10/12/13
Speed	rpm	72 000	72 000	72 000	72 000	72 000
Run-up time	approx. min	2	2	2	2	3
Coolant flow rate at 15 °C*	l/hr	20	20	20	20	20
Forevacuum port	nom. diam.	16 KF	16 KF	16 KF	16 KF	16 KF
Purge gas port	nom. diam.	-	-	-	-	-
Vent port	nom. diam.	-	10 KF	-	10 KF	-
Weight, approx.	kg	2	2	2	2	2
Max. ambient temperature at operation	°C	55	55	55	55	45
Max. bakeout temperature at CF flange	°C	-	80	-	80	-

TURBOVAC		151	151	151 C	361	361	361 C	361 C
High-vacuum port	nom. diam.	63 ISO-K	100 ISO-K 100 CF	100 ISO-K	100 ISO-K 100 CF	160 ISO-K 160 CF	100 ISO-K	160 ISO-K
Pumping speed for N ₂	l/sec	115	145	145	345	400	345	400
Ultimate pressure	mbar	< 10 ⁻¹⁰	< 10 ⁻¹⁰	< 10 ⁻¹⁰	< 10 ⁻¹⁰	< 10 ⁻¹⁰	< 10 ⁻¹⁰	< 10 ⁻¹⁰
Forevacuum pressure	mbar	0.5	0.5	0.5	0.5	0.5	0.5	0.5
Recommended fore-vacuum pump	TRIVAC	D 4 B	D 4 B	D 16 B	D 16 B	D 16 B	D 25 B	D 25 B
Recommended frequency converter	NT	20	20	20	20	20	20	20
Speed	rpm	50 000	50 000	50 000	45 000	45 000	45 000	45 000
Run-up time	approx. min.	2	2	2	2	2	2	2
Coolant connection nozzle	mm	10	10	10	10	10	10	10
Coolant temperature	°C	10 – 25	10 – 25	10 – 25	10 – 25	10 – 25	10 – 25	10 – 25
Coolant flow rate at 15 °C	l·h ⁻¹	20	20	20	20	20	20	20
Forevacuum port	nom. diam.	25 KF	25 KF	25 KF	25 KF	25 KF	25 KF	25 KF
Purge gas port	nom. diam.	-	-	10 KF	-	-	10 KF	10 KF
Vent port	nom. diam.	10 KF	10 KF	10 KF	10 KF	10 KF	10 KF	10 KF
Weight approx.	kg	8	8	8	12	12	12	12
Max. ambient temperature at operation	°C	55	55	55	55	55	55	55
Max. bakeout temperature at CF flange	°C	-	100	-	100	100	-	-

* When using the water cooling option. Cat.no. 854 08

TURBOVAC		600 C	600 C	1000 C	1000 C	1000 C
High-vacuum port	nom. diam.	160 ISO-K 160 CF	6" ANSI	160 ISO-K 160 CF	6" ANSI 200 CF	250 ISO-K
Pumping speed for N ₂	l·s ⁻¹	560	620	850	1100	1150
Ultimate pressure	mbar	< 10 ⁻¹⁰	< 10 ⁻¹⁰	< 10 ⁻¹⁰	< 10 ⁻¹⁰	< 10 ⁻¹⁰
Forevacuum pressure	mbar	10 ⁻³ - 10 ⁻²	10 ⁻³ - 10 ⁻²	10 ⁻³ - 10 ⁻²	10 ⁻³ - 10 ⁻²	10 ⁻³ - 10 ⁻²
Recommended fore- vacuum pump	TRIVAC	D 40 B	D 40 B	D 40 B	D 40 B	D 40 B
Recommended frequency converter	NT	1000/1500	1000/1500	1000/1500 VH	1000/1500 VH	1000/1500 VH
or	NT	20	20	20	20	20
Speed	rpm	36 000	36 000	36 000	36 000	36 000
Run-up time	approx. min.	3	3	4 ¹⁾	4 ¹⁾	4 ¹⁾
Coolant connection nozzle	mm	10	10	11 / 10 ²⁾	11	11 / 10 ²⁾
Coolant temperature	°C	10 - 30	10 - 30	10 - 30	10 - 30	10 - 30
Coolant flow rate at 15 °C	l/hr	30	30	30	30	30
Forevacuum port	nom. diam.	40 KF	40 KF	40 KF/63 ISO-K	40 KF	40 KF/63 ISO-K
Purge gas port	nom. diam.	10 KF	10 KF	10 KF ³⁾	10 KF ³⁾	10 KF ³⁾
Vent port	nom. diam.	10 KF	10 KF	10 KF ³⁾	10 KF ³⁾	10 KF ³⁾
Weight, approx.	kg	17	17	25	25	25
Max. ambient temperature at operation	°C	55	55	55	55	55
Max. bakeout temperature at CF flange	°C	100	-	100	100	-

- 1) with the NT 20: 9 min
- 2) 11 mm with 40 mm type KF forevacuum port
10 mm with 63 mm type ISO-K forevacuum port
- 3) As of 1995 in some cases 16 mm KF

kg	lbs	mm	inch	°C	°F	mbar	Torr
2	4.4	10	0.35	10	50	10 ⁻¹⁰	8·10 ⁻¹¹
8	17.7	11	0.43	15	59	8·10 ⁻⁹	6·10 ⁻⁹
12	26.5			25	77	10 ⁻³	8·10 ⁻⁴
17	37.5			45	113	10 ⁻²	8·10 ⁻³
25	55			55	131	0.5	0.4
				80	176	1	0.8
				100	212	15	11.2

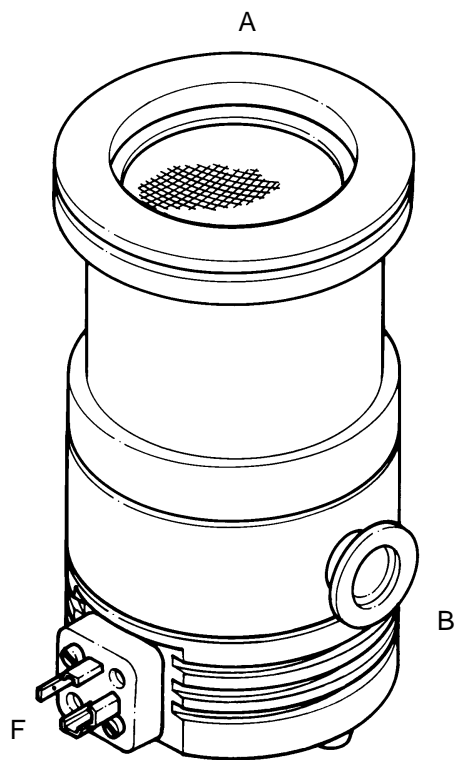

TURBOVAC 50 D2

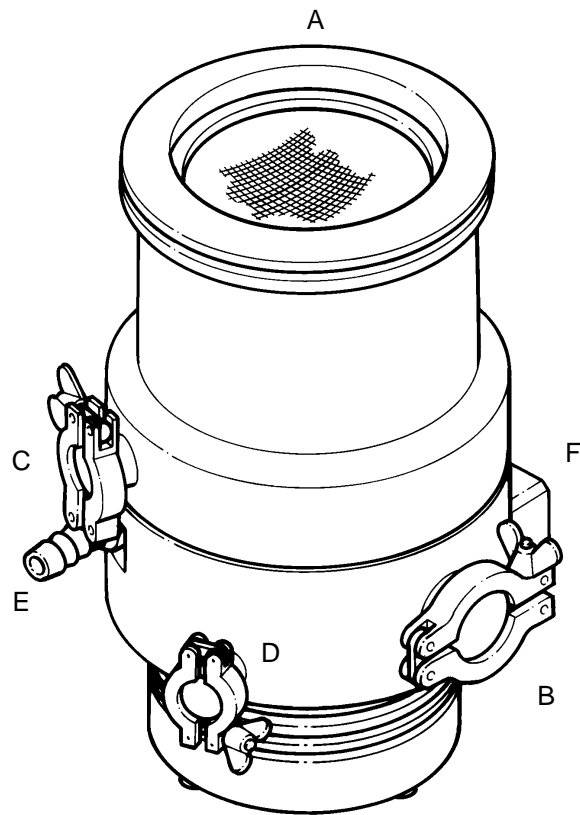

TURBOVAC 151 C; TURBOVAC 361 C is similar

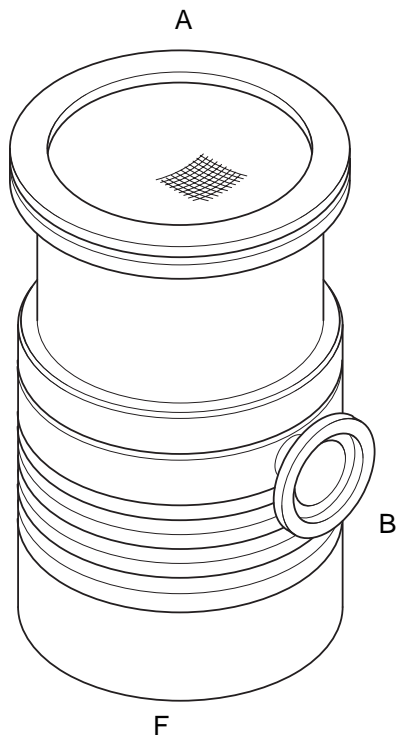

TURBOVAC 50

Fig. 1

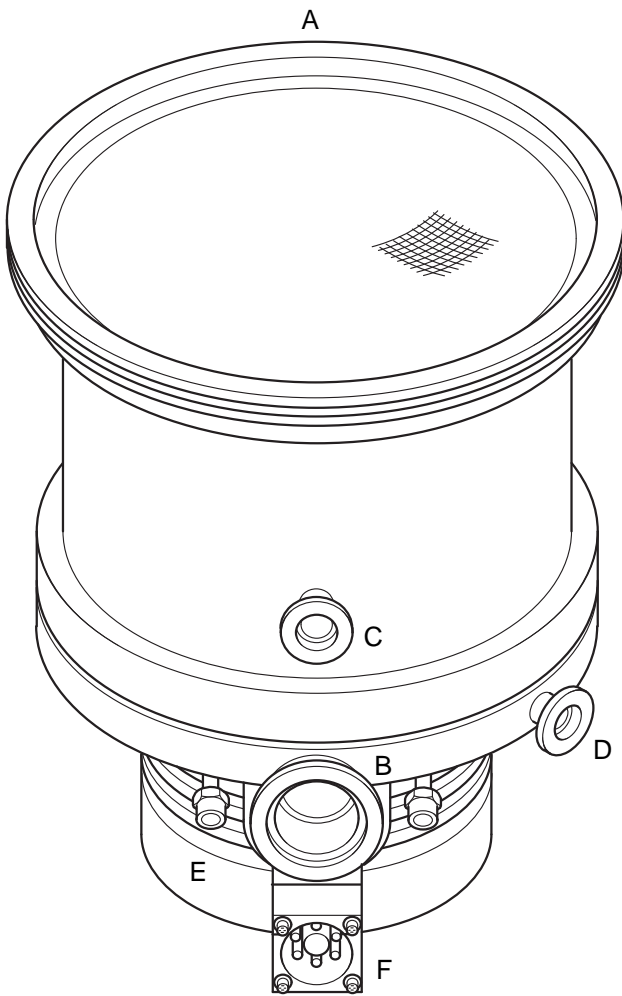

TURBOVAC 600 C

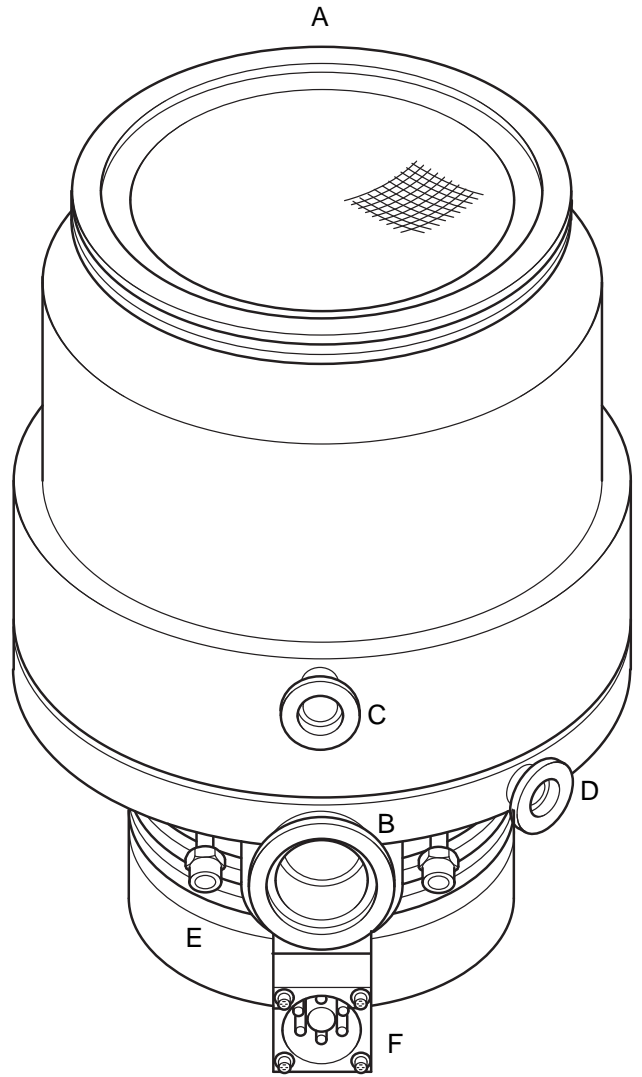

TURBOVAC 1000 C

- A High-vacuum connector flange
- B Forevacuum connector flange
- C Airing flange
- D Purge gas flange
- E Connection for water cooling
- F Electrical connection

Fig. 2

Operating environment and cooling

TURBOVAC	No additional cooling required if all these conditions are satisfied	Air or water cooling required	Water cooling required if any one of these conditions prevails
50 D2	Ambient temperature < 30° C No bakeout operations High-vacuum pressure < 10 ⁻³ mbar Forevacuum pressure < 5·10 ⁻¹ mbar	Ambient temperature 30 to 40 °C Bakeout operations High-vacuum pressure 10 ⁻³ to 10 ⁻² mbar Forevacuum pressure 5·10 ⁻¹ to 2 mbar	Ambient temperature 40 - 45 °C Bakeout operations High-vacuum pressure > 5·10 ⁻² mbar Forevacuum pressure > 2 mbar
50	Continuous operation at high-vacuum pressure < 10 ⁻⁴ mbar Ambient temperature < 45 °C	Bakeout at ambient temperature < 40 °C Continuous operation at high-vacuum pressure > 10 ⁻⁴ mbar Rapid-cycling operation	Ambient temperature 45 - 55 °C Back-out at ambient temperature > 40° C
151, 151 C, 361, 361 C	–	Bakeout at ambient temperature < 35 °C High-vacuum pressure < 10 ⁻³ mbar and ambient temperature < 45 °C	Bakeout at ambient temperature > 35 °C High-vacuum pressure > 10 ⁻³ mbar Ambient temperature 45 - 55 °C
600 C	–	Bakeout at ambient temperature < 35 °C or high-vacuum pressure < 10 ⁻³ mbar and ambient temperature < 45 °C	Bakeout at ambient temperature > 35 °C High-vacuum pressure > 10 ⁻³ mbar Ambient temperature 45 - 55 °C
1000 C	–	Bakeout at ambient temperature < 35° C or high-vacuum pressure < 10 ⁻⁴ mbar and ambient temperature < 45 °C	Bakeout at ambient temperature > 35 °C High-vacuum pressure > 10 ⁻⁴ mbar Ambient temperature 45 - 55 °C

2 Connections

Caution

Unless appropriate accessories and attachments are used, the TURBOVAC is **not** suitable for aggressive or corrosive media, or those containing dust. When handling corrosive media the C version pump must be operated with purge gas; when handling media containing dust, a fine-mesh filter must be installed.

Observe the information on media compatibility, to be found at the beginning of these operating instructions.

Do not open the packaging until immediately prior to installation.

Remove the covers and the blank flanges at the turbomolecular pump only just before installing, to ensure that the TURBOVAC is installed under the cleanest possible conditions.

When moving the heavier pumps, the lower surfaces on the base flange are suitable for accepting a lifting fork; see Fig. 3.

°C	°F	mbar	Torr
30	86	10 ⁻⁴	8·10 ⁻⁵
35	95	10 ⁻³	8·10 ⁻⁴
40	104	10 ⁻²	8·10 ⁻³
45	113	5·10 ⁻²	4·10 ⁻²
50	122	5·10 ⁻¹	4·10 ⁻¹
55	131	2	1.5

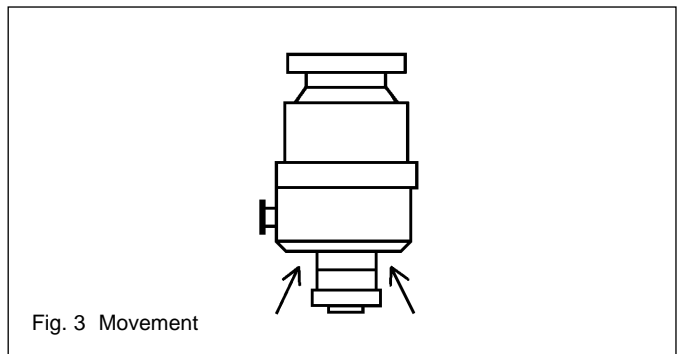

Fig. 3 Movement

Caution

Take care not to damage the plugs and coolant connections during movement.

Do not stand below the TURBOVAC pump while it is being connected to or detached from the system.

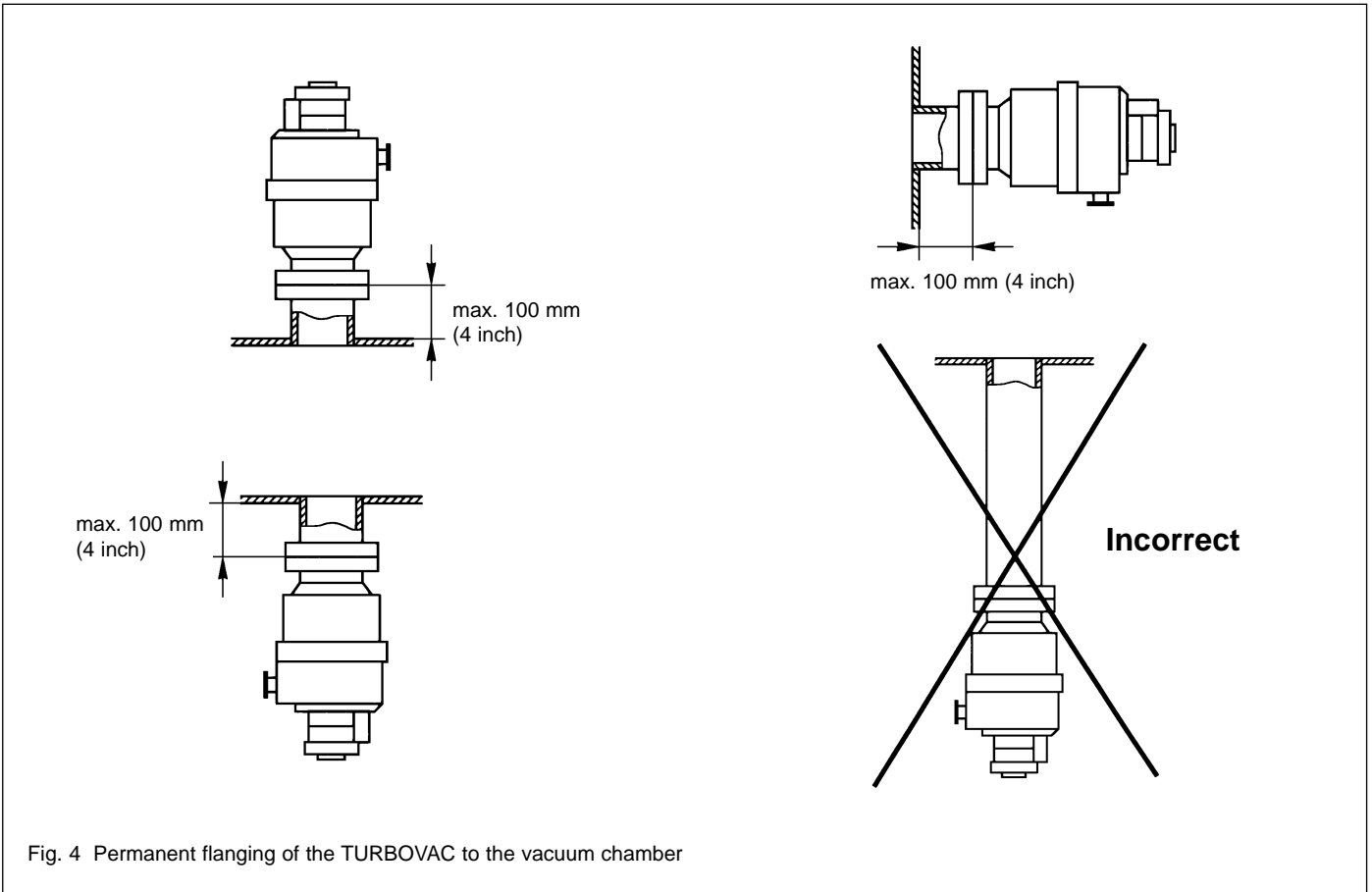

Fig. 4 Permanent flanging of the TURBOVAC to the vacuum chamber

2.1 Operating environment

When using the TURBOVAC inside a magnetic field, the magnetic induction at the pump housing surface may not exceed the following values:

TURBOVAC 50: B = 7 mT

TURBOVAC 151 – 1000:

B = 5 mT in case of radial impingement

B = 15 mT in case of axial impingement

Provide suitable shielding measures if these values are exceeded.

The standard version is resistant to radiation at levels up to 10^3 Gy.

1 mT (milliTesla) = 10 G (Gauss)

1 Gy (Gray) = 100 rad

2.2 Connecting the pump to the vacuum chamber

Remove the packing flange from the high-vacuum flange. Pay attention to maintaining maximum cleanliness during connection work.

Warning



The high-vacuum flange must be securely attached to the vacuum chamber. If the pump were to become blocked, insufficient attachment could cause the pump to break away from its mount or allow internal pump parts to be discharged. Never operate the pump (in bench tests, for instance) without its being flanged to the vacuum chamber.

If the pump should suddenly seize, the ensuing deceleration torque will have to be absorbed by the system. To accomplish this, the following are required when securing an ISO-K type high-vacuum flange:

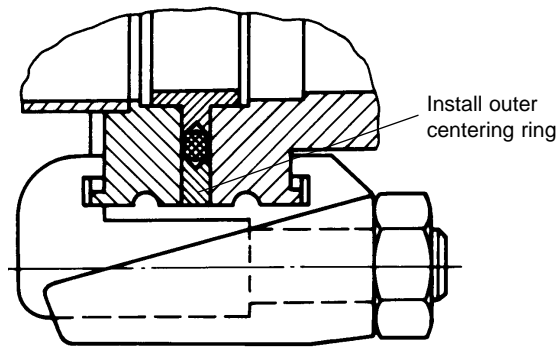

Fig. 5 Using ISO-K flanges

TURBOVAC		Braking torque [Nm]	Clamping bolts
50		63	4
50 D2		150	4
151/151 C		283	4
361/361 C		580	6
600 C		1486	10
1000 C	DN 160	1500	16
	DN 250	1500	10

Clamping bolts made of steel must be torqued down to 35 Nm, those made of stainless steel to 50 Nm.

When installing CF flanges, use only the bolts specified (tightening torque is 15 Nm for DN 40 CF, 30 Nm for DN 63 CF and larger).

Nm	15	30	35	50
ft-lb	11	22	26	37

You will find the order numbers for the (clamping) bolts in the Leybold Catalog.

The clamping bolts are **not** included as standard equipment with the pump.

Warning



The small-flange connector for the high-vacuum flange at the TURBOVAC 50 is not strong enough to keep the pump from rotating if it should suddenly seize. Rotation of the pump can cause leaks in the forevacuum line.

Secure the pump additionally to prevent rotation in case it should suddenly seize.

In most applications the TURBOVAC will be flanged direct to the high-vacuum flange for the system. The design of the lubricating system makes it possible to mount and run the TURBOVAC in any desired attitude. It is not necessary to support the pump.

If there is a danger that dust could pass from the vacuum chamber into the TURBOVAC, install a fine-mesh filter between the vacuum chamber and the TURBOVAC.

The TURBOVAC is precision balanced and is generally operated without a vibration damper. A special-design vibration damper is available for mounting at the TURBOVAC high-vacuum flange to decouple extremely sensitive equipment and to prevent external vibrations from being transferred to the TURBOVAC. If the TURBOVAC 1000 C are flanged via a vibration damper secure it in addition at the base flange.

Design with ISO-K clamp flange

Fit the O-ring at the centering ring.

The O-ring should be flat and even; it must not be twisted. Then add the outer ring.

A collar flange with retaining ring and suitable sealing washer can also be used to connect the TURBOVAC.

A collar flange is required when using ultra-high-vacuum sealing washers.

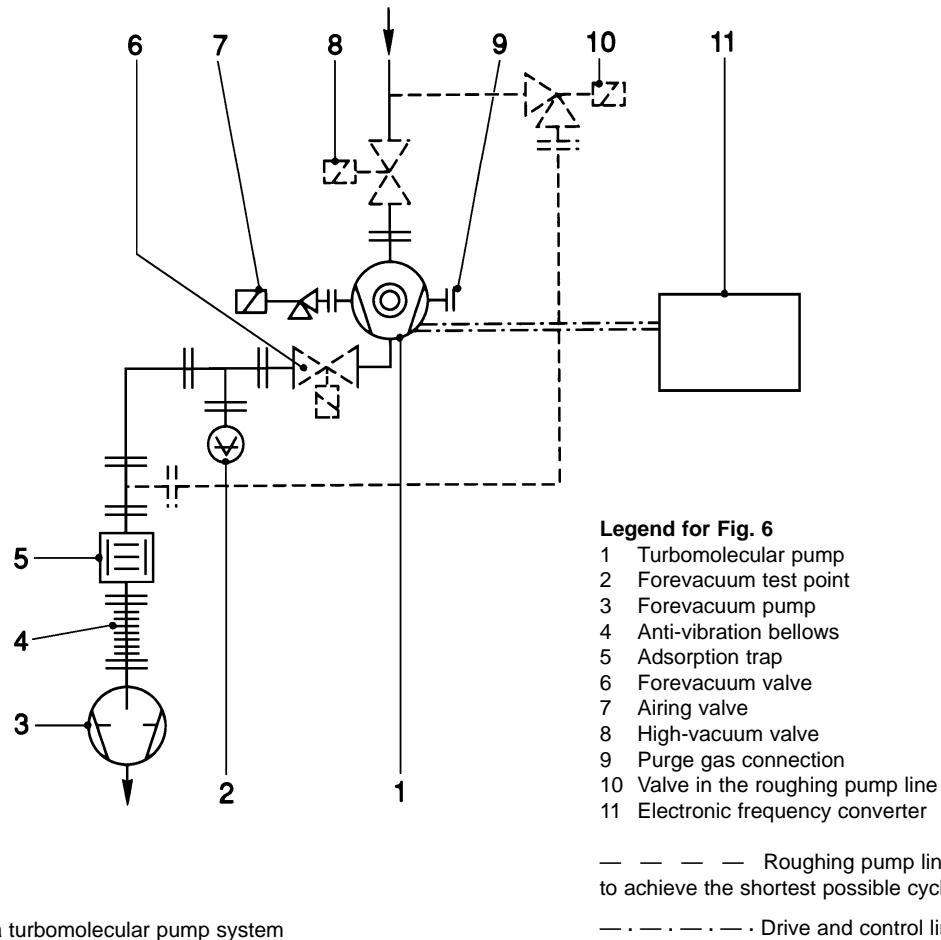

Fig. 6 Schematic of a turbomolecular pump system

Splinter guard

A splinter guard is installed in the high-vacuum flange to protect the TURBOVAC.

Operate the pump only with this splinter guard in place as foreign objects passing through the intake port and into the pump can cause serious damage to the rotor. Damage caused by foreign objects in the rotor section is excluded from the guarantee.

Flange heating

(only for pumps with the CF flange)

The flange heater is used to bake out, under automatic control, the high-vacuum connection port at the TURBOVAC and the mating flange on the vacuum chamber.

The bakeout jacket or flange heater is mounted directly to the TURBOVAC intake flange. This can be done even with the pump flanged to the vacuum chamber.

Warning



The bakeout jacket can become so hot during operation (> 80°C, 176 °F) as to represent a burn hazard. Shield the hot components against contact.

The pump running noise is below 70 dB(A); no noise-insulating measures are required.

2.3 Making the forevacuum connection

A suitable forevacuum pump is to be connected to the forevacuum connection flange.

Fig. 6 shows schematically the design of a pump system incorporating a TURBOVAC turbomolecular pump and a TRIVAC forevacuum pump with anti-suckback valve.

When using a forevacuum pump not having an anti-suckback valve, a separate safety valve should be provided. The safety valve keeps oil from backstreaming from the forevacuum pump and into the TURBOVAC when the system is not running.

We recommend installing a sorption trap in the forevacuum line to insure that the forevacuum chamber in the TURBOVAC remains largely free of oil vapors during operation, as well.

Install a roughing pump line to achieve the shortest possible cycling times.

Be sure that there is sufficient vibration decoupling between the TURBOVAC and the forevacuum pump.

Warning



The forevacuum line must be tight. Hazardous gases could escape from leaks or the gases being pumped could react with air or humidity.

2.4 Connecting the cooling

Air cooling

The air cooling unit is available as a supplementary kit for retrofitting.

When installing the air-cooled TURBOVAC, ensure that there is an unrestricted flow of air to the fan.

Always maintain a minimum distance of 20 cm (8 inch) to the nearest object.

Ensure that no heated air from neighboring equipment will be drawn in by the fan.

Connect the fan in the air ventilation unit to the AC mains.

Make the electrical connection for the ventilation unit in such a way that it will be started and stopped together with the pump itself.

Observe the information given in the operating instructions for the air ventilation unit (GA 05.199).

Water cooling

When attaching the water cooling unit to the TURBOVAC 50 and 50 D, remove the pump foot and then bolt the cooling unit to the bottom of the pump. The mounting bolts are provided with the water cooling unit.

Connect the coolant hoses to the hose nipples and secure with hose clamps.

If the coolant flow is turned on and off by means of a solenoid valve, make the electrical connection in such a way that coolant flow will be started and stopped together with the pump itself.

Cooling water specifications

Inlet pressure	3 to 7 bar absolute
Cooling water requirement, Inlet temperature	See Fig. 7
Appearance	Colorless, clear, free of oils and greases
Sediments	< 250 mg/l
Particle size	< 150 µm
pH value	7 to 8.5
Overall hardness (total alkaline earths) max. 20 ° German hardness scale (= 3.57 mmol/l)	

2.5 Connecting the purge gas and airing device

Suited are all gases,

- which will not cause corrosion or pitting in aluminium and steel and
- which in connection with process deposits in the pump will not cause corrosion or sticking.

For venting and as the purge gas we recommend inert gases like nitrogen or argon. The temperature of these gases should be between 5 °C and 80 °C, max. relative humidity should not exceed 10 ppm.

In individual cases and after consultation also dry, filtered, oil-free air or filtered ambient air may be used (filter mesh < 1µm).

Change the filters after some time, at least annually.

Different venting methods are described in Chapter 3.5.

TURBOVAC 50, 50 D 2 with ISO-K connectors

The TURBOVAC is aired through the system.

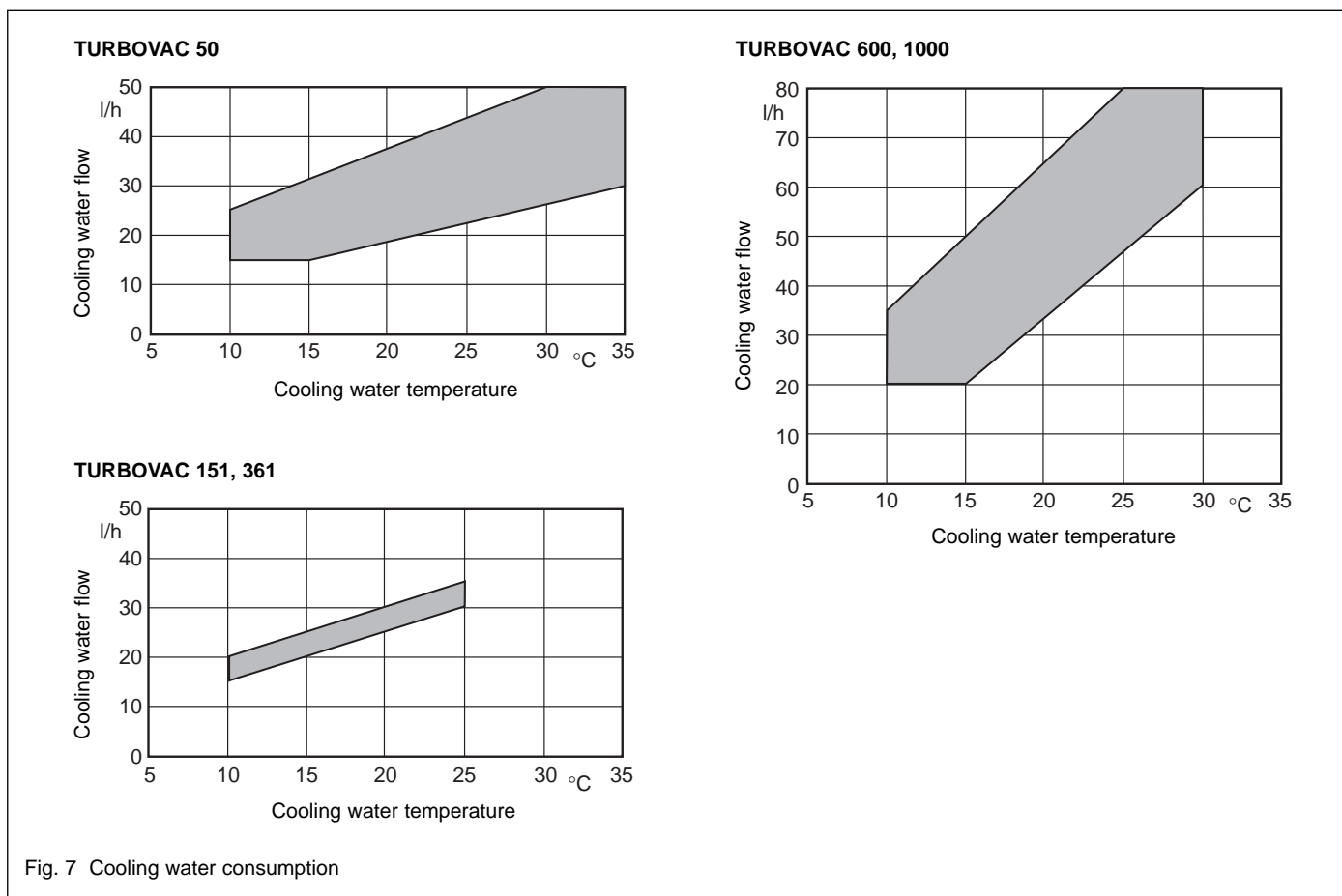

TURBOVAC 50 with CF connectors and TURBOVAC 151, 361

If the pump cannot be aired through the system, then a power failure airing valve shall be attached to the airing connection flange. This power failure airing valve prevents oil vapor from the forevacuum line from diffusing back into the system.

TURBOVAC 151 C, 361 C, 600 C and 1000 C

Either attach a power failure airing valve to the airing connection flange or a purge gas and airing valve at the purge gas connection flange.

Which of the two flanges is used will depend on the process.

When pumping **clean, non-corrosive gases**, a power failure airing valve is to be attached.

When pumping **reactive media**, connect a purge gas and airing valve.

Please contact Leybold for assistance in making the decision as to which media can be pumped with or without purge gas.

In processes which require purge gas the pump will have to be aired, when it is switched off, through the purge gas valve.

Observe the operating instructions for the purge gas and airing valve.

2.6 Connecting the TURBOTRONIK

Use the connector cable to attach the TURBOVAC and the TURBOTRONIK; see the operating instructions on the TURBOTRONIK for details.

Warning



Operate the pump only with the matching frequency converter and connector line. Voltages of up to 400 V will be present at the connection cable between the frequency converter and the pump; mains voltage will be present at the fan, the flange heater, the valves and their supply leads. Route the conductors and cables so as to protect them from damage.

The connections are of the IP 40 safety classification. Do not expose the pump, frequency converter or connectors to dripping water.

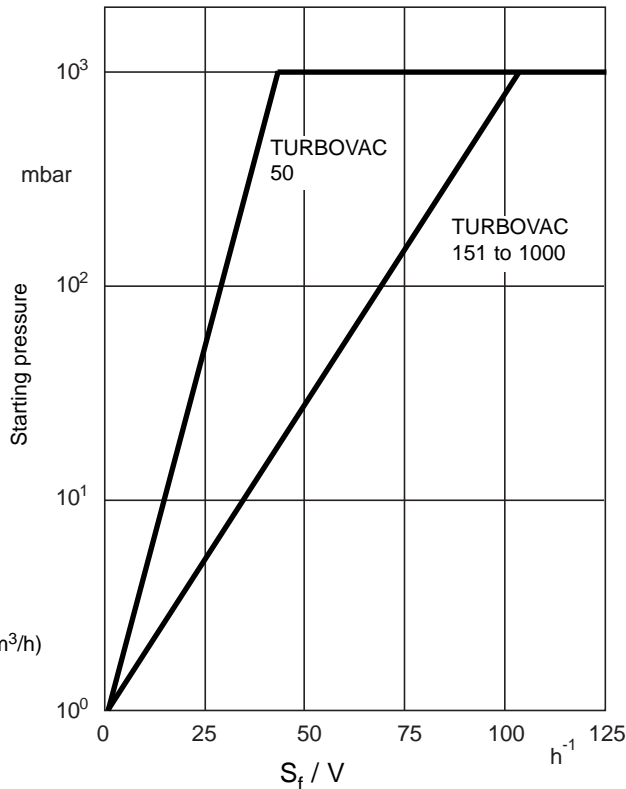

Fig. 8 Determining the starting pressure for a TURBOVAC when evacuating larger volumes

3 Operation

3.1 Switching on

The starting pressure for the TURBOVAC can be read from the chart reproduced in Fig. 8.

Where $S_f / V > 100[h^{-1}]$, the forevacuum pump and the TURBOVAC can be switched on simultaneously.

In such a situation the TURBOVAC serves from the very outset as an effective baffle.

When dealing with larger volumes, the vacuum chamber will first have to be pumped down with the forevacuum pump.

Then switch on the cooling and the TURBOVAC (at the TURBOTRONIK).

Kindly refer to the TURBOTRONIK operating instructions for details.

Avoid impact and vibration while the pump is running.

3.2 Bakeout

If pressures in the range of 10^{-8} mbar are to be developed within a short period of time, the vacuum chamber and the components installed therein will have to be baked out. In addition, the TURBOVAC can be baked out using the flange heater provided for this purpose.

Protect the rotor against intensive, direct heat radiation. When baking out at the forevacuum side – at a sorption trap, for example – ensure that the components attached direct are not heated to more than $80\text{ }^{\circ}\text{C}$ ($176\text{ }^{\circ}\text{F}$).

The forevacuum pump must be in operation so as to eliminate the vapors liberated at the sorption trap.

3.3 Operation

Caution

Exposure of the pump to accelerating forces must be avoided or reduced to such an extent that the rotor unit will not be excited by vibrations. In the case of critical applications you must consult our Applications Dept. first.

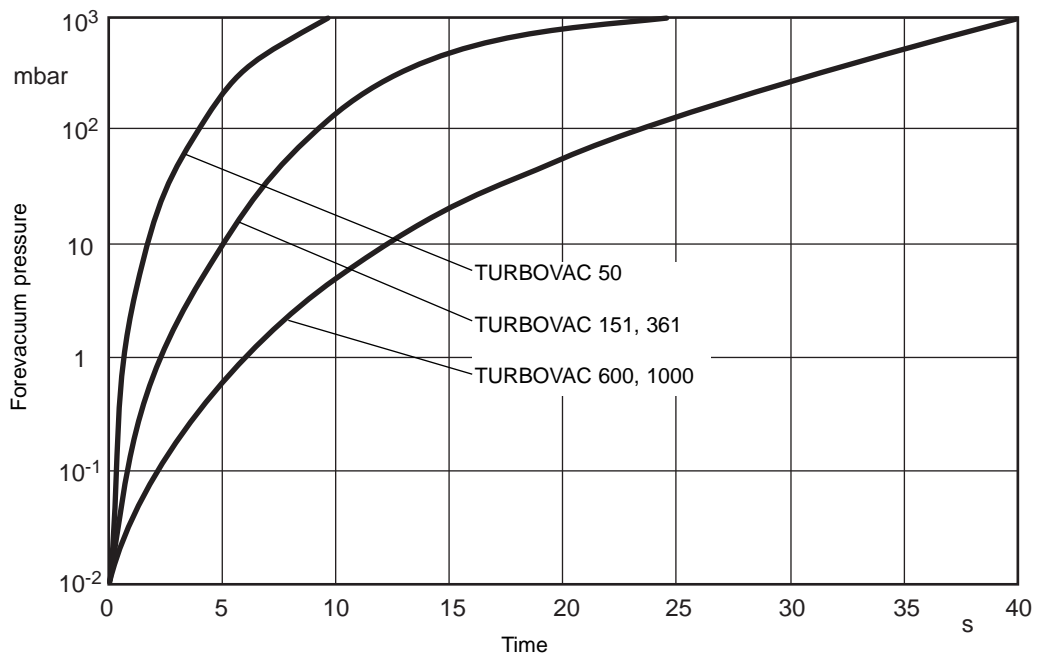

Fig. 9 Curves showing the pressure rise

3.4 Switching off

Switch off the TURBOVAC at the TURBOTRONIK.

Refer to the TURBOTRONIK operating instructions for details.

Switch off the forevacuum pump.

Air the TURBOVAC before it has come to a full standstill; refer to Section 3.5.

In TRIVAC pumps the built-in anti-suckback valve will close automatically and shut off the forevacuum line. When using forevacuum pumps without an anti-suckback valve, close the valve in the forevacuum line.

Close off the cooling water supply or switch off the ventilation immediately after switching off the TURBOVAC in order to avoid condensate formation in the pump.

If the pump previously handled corrosive gases, it will be necessary to purge the pump with dry nitrogen for one hour prior to shut-down. When the system is not in operation, ensure that neither ambient air nor cleaning agents can enter the TURBOVAC.

3.5 Venting

As to suitable gases, see Chapter 2.5.

Venting Methods

There are three different methods of venting the turbomolecular pump.

In the case processes requiring a purge gas, the pump must be vented via the **purge gas and venting valve** when shutting the pump down.

When additionally venting the vacuum chamber, the venting function of the purge gas and venting valve must be opened before opening the chamber valve. This will ensure the presence of a higher pressure in the area of the ball bearings compared to the remaining vacuum area. This will prevent particles, dust or aggressive gases from being forced through the bearings into the not yet vented motor chamber of the pump.

Cautious venting of the pump is possible from the **high vacuum side**, since here the bearing forces will be lowest. When doing so, no free jet of gas must be allowed to form on the rotor so as to avoid exposing the rotor to additional forces.

When venting the pump through its **foreline connection**, neither oil nor particles may be entrained in the gas flow from the forevacuum side into the pump.

Speed of the Pressure Rise

All turbomolecular pumps may be vented at full speed. However, the pressure must not increase faster than specified through the pressure rise curve.

The pump must be vented significantly slower when there is the risk of particles entering into the pump from the process. During venting, the flow must be of the laminar type in both the vacuum chamber and the turbomolecular pump.

The speed of the pressure rise during venting of the running pump will greatly influence the load on the rotor/stator pack and the bearings. The slower the pump is vented, the longer the service life of the bearings will be.

The pump must not be vented to pressures above atmospheric pressure.

3.6 Removing the pump from the system

Switch off the pump and vent it as per the instructions in Sections 3.4 and 3.5.

Warning



Take the appropriate precautionary measures prior to opening the intake or discharge connection if the pump has previously handled hazardous gases.



If necessary, use gloves, a respirator and/or protective clothing and work under an exhaust hood.



If the pump previously handled corrosive gases, then allow the purge gas to flow for as long as possible before detaching the pump from the system.

Remove the TURBOVAC from the system.

TURBOVAC pumps which are used in semiconductor processes, for example, will be contaminated with process gases. These gases may be toxic and hazardous to health. In addition, deposits with similarly dangerous properties may have formed. Many of these gases and deposits form acids when they come into contact with humid air. This will result in serious corrosion damage to the pump.

To avoid health hazards and corrosion damage when the pumps are detached from the system, lay a container of desiccant on the splinter guard and then close the pump immediately at all flange connections. Store the pump, with a desiccant, in a PE bag.

A packing set is included with TURBOVAC models with a "C" in the type designation. Use this packing set after detaching the pump from the system.

Faulty (leaky) packing of a TURBOVAC will nullify the guarantee.

Ordering data

Packing set for high-vacuum connection flange	Order No.
DN 100/160	200 91 240
DN 200	200 91 295
DN 250, 6" ANSI	200 91 262

Pack the pump so that it cannot be damaged during shipping and so that no contaminants can escape from the packaging. Protect in particular the flanges, the coolant connection nipples and the cable grommets.

If you return a pump to Leybold, be absolutely sure to observe the instructions given in Section 4.2.

4 Maintenance

After 15,000 operating hours at the latest a standard bearing exchange will be recommended for the TURBOVAC 50 to 361 C. For the TURBOVAC 600 C and 1000 C a standard bearing exchange will be required after 10,000 operating hours at the latest. Moreover we recommend to have the rotor assy. exchanged, depending on the thermal stress on the rotor, after 45,000 to 100,000 operating hours. This can only be done by Leybold Service. For this ask for a quotation.

When using purge gas valves

Depending on the degree of contamination of the purge gas used the filter will clog and will have to be exchanged (our experience indicates that this will become necessary after 1 to 6 months).

When using an adsorption trap

Regenerate or renew the adsorption agent regularly; refer to the operating instructions provided with the trap.

Caution

The pump must only be opened by such persons who have been authorised by Leybold to do so.

4.1 Cleaning

Contamination inside the TURBOVAC is indicated by a deterioration in performance, i.e. an increasing decline in working pressure.

If there is only slight contamination, such as a coating on the TURBOVAC interior surfaces due to exposure to the atmosphere over an extended period of time, for the CF version the flange heater can be used for cleaning.

The ultimate pressure must be monitored while baking out under vacuum.

When making the initial examination of the pump, mount blank flanges to eliminate any possibility of leaks and desorption in the vacuum chamber.

The pump will have to be disassembled if there is more extensive contamination. The LEYBOLD Customer Service Department will have to be consulted here in all cases.

Caution

The rotor is precision balanced; any change whatsoever, such as loosening or bending any rotor component, will make re-balancing necessary.

4.2 Service by LEYBOLD

Whenever you send a pump to LEYBOLD, indicate whether the pump is contaminated or is free of substances which could pose a health hazard. If it is contaminated, specify exactly which substances are involved. You must use the form we have prepared for this purpose; we will forward that form on request.

A copy of the form is printed at the end of the operating instructions: "Declaration of contamination for vacuum equipment and components". Another suitable form is available from the Leybold homepage:

<http://www.leyboldvac.de> under the headline "customer service".

Attach the form to the pump or enclose it to the pump. Do not place it together with the pump inside the PE bag.

This statement detailing the contamination is required to satisfy legal requirements and for the protection of our employees.

LEYBOLD must return to the sender any pumps which are not accompanied by a contamination statement.

5 Troubleshooting

Warning



When the connector cable to the TURBOVAC is attached, the outputs of the TURBOTRONIK frequency converter are not free of voltage.

Before commencing troubleshooting procedures, make the following simple checks:

Is the TURBOVAC being supplied with electrical energy?

Are the connections . . .

- from the mains power cord to the frequency converter
- at the connector cable from the frequency converter to the mains network in good working order?

If a water flow monitoring device is connected, is it functioning properly?

Check the water flow monitoring device by jumping its terminals and starting the TURBOVAC.

Is the forevacuum pressure sufficient?

Is the vacuum chamber free of leaks?

Observe also the troubleshooting instructions for the TURBOTRONIK.

Malfunction	Possible cause	Rectification
TURBOVAC does not start.	Motor connection cable not attached, is loose or is defective. Pump has seized.	Check the motor connection cable and connect correctly; replace if necessary. Replace the pump.
TURBOVAC generates loud running noises and vibrations.	Rotor is out of balance. Bearing is defective. Pump running within the natural frequency range of the system, causing resonance.	Balance the rotor (only by the Leybold Service Department). Bearings will have to be replaced (only by the Leybold Service Department). Change the masses of the system or install vibration damper to isolate oscillations.
The TURBOVAC does not achieve ultimate pressure.	Measurement device is defective. Measurement gauges are soiled. Leak at the system, lines or pump. Minor grime collection at the pump. The pump is oily. Forevacuum pump with insufficient pumping speed or ultimate pressure which is too high. Leak at the power cord passage port. TURBOVAC is rotating in the wrong direction.	Check the measurement device. Clean or replace the measurement gauges. Locate the leaks. Bake out the pump; see Section 4.1. Have the pump cleaned (only by the Leybold Service Department). Check ultimate pressure of the forevacuum pump or install a more powerful forevacuum pump. Locate and repair leaks (only by the Leybold Service Department). Check the connector lines; interchange poles if necessary.
TURBOVAC overheats (malfunction indication at the TURBOTRONIK).	Forevacuum pressure too high. Gas volume too great / leak in the system. Ventilation unit blocked. Ambient temperature is too high. Cooling water is lacking or insufficient. Bearings are defective.	Check the forevacuum pump; install a more powerful forevacuum pump if necessary. Seal leak; install a more powerful forevacuum pump if necessary. Ensure sufficient supply of cooling air. Route cooler air to the fan or employ water cooling option. Ensure sufficient supply of cooling water. Have the pump repaired (only by the Leybold Service Department).
The TURBOVAC or the vacuum chamber is contaminated with oil.	Anti-suckback valve at the forevacuum pump is defective. The TURBOVAC was not aired or improperly aired when shut down. System configured incorrectly: oil vapor streams back during forepump operation. Sorptions trap is saturated.	Repair or replace the forevacuum pump. Check the airing valve and replace if indicated. Air the TURBOVAC correctly; see Section 3.5. Install a roughing line or pre-pump for a shorter period of time or install a sorptions trap. Regenerate or replace the sorptions trap.

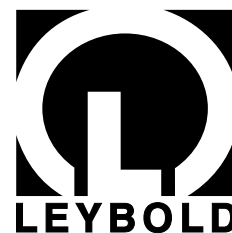

EC Manufacturer's Declaration

in the spirit of Appendix IIb to the 89/392/EEC Machinery Guidelines

We, the Leybold Vakuum GmbH, declare herewith that the commissioning of the incomplete machine designated below is prohibited until such time as it has been determined that the system in which this complete machine is to be installed corresponds with the EC Machinery Guidelines.

At the same time we certify conformity with the Low-Voltage Guidelines 73/23/EEC.

When using the appropriate Leybold accessories, e.g. connector lines, flange heaters or fans, and when powering the pump with the specified Leybold frequency converters, the protection level prescribed in the EMC Guidelines will be attained

Designation: Turbomolecular pump

Models: TURBOVAC 50
TURBOVAC 50 D2
TURBOVAC 151, 151 C
TURBOVAC 361, 361 C
TURBOVAC 600 C
TURBOVAC 1000 C

Catalog numbers:

854 00/01/02, 800150V0010

856 68

856 30/31/32/33/35

856 70/71/72/73/74/75/77

856 82

855 35/36/38/39, 894 89

As from serial No. A 95

Applicable, harmonized standards:

- EN 292 Part 1 and Part 2 November 1991
- EN 1012 Part 2 1996
- EN 60 204 1993

Applied national standards and technical specifications:

- DIN 31 001 April 1983
- DIN ISO 1940 December 1993

Cologne, September 19, 2002



Dr. Beyer, Design Dept. Manager

Cologne, September 19, 2002

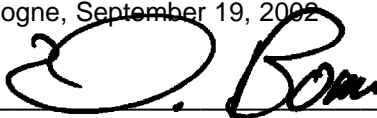

Mr. Bonn, Turbomolecular Pump
Engineering Manager

Sales and Service Net Worldwide

EUROPE

Germany:

LEYBOLD VAKUUM GmbH
Bonner Straße 498 (Bayenthal)
D-50968 Cologne
e-mail:
sales@leyboldvakuum.com
Phone: +49-221-347 1234
Fax: +49-221-347 1245

LEYBOLD VAKUUM GmbH
SERVICE CENTER
Emil-Hoffmann-Strasse 43
50996 Cologne-Suerth
e-mail:

service@leyboldvakuum.com
Phone: +49-221-347 14 39
Fax: +49-221-347 19 45

Belgium:

LEYBOLD VACUUM
Nederland B.V.
Belgisch bijkantoor
Leuvensesteenweg 542, 9A
1930 Zaventem
e-mail: info@leybold.be

Sales:
Phone: +32-2-711 00 83
Fax: +32-2-720 83 38
Service:
Phone: +32-2-711 00 82
Fax: +32-2-720 83 38

France:

LEYBOLD VACUUM
FRANCE S.A.
7, Avenue du Quebec
Z.A. de Courtaboeuf, B. P. 42
91942 Courtaboeuf Cedex
e-mail:
leybold-vacuum@leybold.fr
Sales and Service:
Phone: +33-1-69 82 48 00
Fax: +33-1-69 07 57 38

Great Britain:

LEYBOLD VACUUM UK LTD.
Waterside Way, Plough Lane
London SW17 0HB
Sales:
e-mail: sales@leybold.co.uk
Phone: +44-20-8971 7000
Fax: +44-20-8971 7001
Service:
e-mail:
service@leybold.co.uk
Phone: +44-20-8971 7030
Fax: +44-20-8971 7003

Italy:

LEYBOLD VACUUM
ITALIA S.p.A.
8, Via Trasimeno
20128 Milano
Sales:
e-mail: sales@leybold.it
Phone: +39-02-27 22 31
Fax: +39-02-27 20 96 41
Service:
e-mail: service@leybold.it
Phone: +39-02-27 22 31
Fax: +39-02-27 20 96 41

Netherlands:

LEYBOLD VACUUM
NEDERLAND B.V.
Computerweg 7
3542 DP Utrecht
e-mail: mail@leybold.nl
Sales and Service:
Phone: +31-346-58 39 99
Fax: +31-346-58 39 90

Spain:

LEYBOLD VACUUM
ESPAÑA S.A.
C/. Huelva, 7
08940 Cornellà de Llobregat (Barcelona)
e-mail:
leybold@leyboldspain.com
Sales:
Phone: +34-93-666 46 16
Fax: +34-93-666 43 70
Service:
Phone: +34-93-666 49 51
Fax: +34-93-685 40 10

Sweden:

LEYBOLD VACUUM
SCANDINAVIA AB
Box 9084
40092 Göteborg
e-mail: info@leybold.se
Sales and Service:
Phone: +46-31-68 84 70
Fax: +46-31-68 39 39

Switzerland:

LEYBOLD VAKUUM
SCHWEIZ AG
Leutschenbachstrasse 55
8050 Zürich
e-mail: sales@leybold.ch
Sales:
Phone: +41-1-308 40 50
Fax: +41-1-302 43 73
Service:
Phone: +41-1-308 40 62
Fax: +41-1-302 43 73

AMERICAS

USA:

LEYBOLD VACUUM USA INC.
5700 Mellon Road
Export, PA 15632
e-mail:
info@leyboldvakuum.com

Sales:
Eastern & Central time zones
Phone: +1-724-327-5700
Fax: +1-724-733-1217
Pacific, Mountain,
Alaskan & Hawaiian time zones
Phone: +1-480-752-9191
Fax: +1-480-752-9494

Service:
Phone: +1-724-327-5700
Fax: +1-724-733-3799

ASIA

P.R. China:

LEYBOLD VACUUM
(Tianjin)
International Trade Co., Ltd.
Beichen Economic Development Area (BEDA), Tianjin,
300400, China.
Phone: +86-22-26970808
Fax: +86-22-26974061,
+86-22-26972017
E-mail:
leybold@leybold.com.cn

LEYBOLD (Tianjin)
VACUUM Equipment Manufacturing Co. Ltd
Beichen Economic Development Area (BEDA), Tianjin,
300400, China.
Phone: +86-22-26970808
Fax: +86-22-26974061
+86-22-26972017
E-mail:
leybold@leybold.com.cn

LEYBOLD VACUUM
(Tianjin)
International Trade Co., Ltd.
Shanghai Branch:
Add: No.33, 76 Futedong
San Rd., Waigaoqiao FTZ, Shanghai,
200131, China.
Phone: +86-21-5064-4666
Fax: +86-21-5064-4668
E-mail:
leybold_sh@leybold.com.cn

LEYBOLD (Tianjin)
VACUUM Equipment Manufacturing Co.Ltd.
Guangzhou Branch:
Add: G/F,#301 Building,
110 Dongguangzhuang Rd,
Tianhe District,Guangzhou
510610, China.
Phone: +86-20-8723-7873
Phone : +86-20-8723-7597
Fax: +86-20-87237875
E-mail:
leybold_gz@leybold.com.cn

Japan:

Sales:
LEYBOLD VACUUM
Japan Co., Ltd.
Head Office
Tobu A.K.Bldg.
4th Floor 23-3,
Shin-Yokohama 3-chome
Kohoku-ku, Yokohama-shi
Kanagawa-ken 222-0033
Phone: +81-45-4713330
Fax: +81-45-4713323

Sales:
LEYBOLD VACUUM
Japan Co., Ltd.
Osaka Branch Office
MURATA Bldg.7F
2-7-53, Nihi-Miyahara, Yodogawa-ku
Osaka-shi 532-0004
Phone: +81-6-6393-5211
Fax: +81-6-6393-5215

Service:
LEYBOLD VACUUM
Japan Co., Ltd.
Tsukuba Technical S.C.
Tsukuba Minami Daiichi
Kogyo Danchi
21, Kasumi-no-Sato,
Ami-machi nashiki-gun
Ibaraki-ken, 300-0315
Tel.: +81-298-89-2841
Fax: +81-298-89-2838

Korea:

LEYBOLD VACUUM
Korea Ltd.
#761-47, Yulkeum-ri,
SungHwan-eup, Chonan
Choongchung-Namdo,
330-807, Korea
Sales:
Tel.: +82-41-580-4431
Fax: +82-41-588-3737
Service Center:
Phone: +82-41-588-3765
Fax: +82-41-588-3769

Singapore:

LEYBOLD VACUUM
Singapore Pte Ltd. No.1,
International Business Park,
B1-20B, The Synergy
Singapore 609917
Phone: +65-66652910
Fax: +65-65668202
vacuum@leyboldvac.com.sg

Taiwan:

LEYBOLD VACUUM
Taiwan Ltd.
2F, No 416-1, Sec.3
Chung-Hsin Rd., Chu-Tung
Hsin-Chu, Taiwan, R.O.C.
Phone: +886-3-5833988
Fax: +886-3-5833999



LEYBOLD VAKUUM GmbH

Bonner Strasse 498 (Bayenthal)
D-50968 Cologne
Tel.: ++49 221 347-0
Fax: ++49 221 347-1250
http://www.leybold.com
e-mail:documentation@leyboldvac.de