

Vacuum Pumps

Instrumentation

Fittings and Valves



LEYBOLD VACUUM

GA 03.108/7.02



**PTB**  
**SALES**

FOR SALES AND SERVICE PLEASE CALL:  
**PTB SALES** T :: 866.332.0500  
 F :: 626.334.2151  
 www.ptbsales.com

DATE SERVICED: \_\_\_\_\_

**VIEW OUR INVENTORY**

**RUVAC WS/WSU  
151/251/501/1001/2001**

**Roots pumps with  
mineral oil or PFPE filling**

Cat.-No.  
117 12/22/32/42/52  
117 13/23/33/43/53  
117 17/27/37/47/57  
117 28/38

917 12/22/32/42/52  
917 13/23/33/43/53  
917 17/19/27/29/37/47  
917 18/28/38/48

**Operating Instructions**

**Contents**

	<b>Page</b>
<b>1 Description</b>	<b>3</b>
1.1 Design and function	3
1.2 Standard specification	6
1.3 Technical data	7
1.4 Accessories	11
<b>2 Transportation and storage</b>	<b>12</b>
<b>3 Installation and connection</b>	<b>13</b>
3.1 Installation	13
3.2 Filling in of the lubricants	13
3.3 Electrical connections	14
3.4 Connection of the flanges	16
<b>4 Operation</b>	<b>17</b>
4.1 Start-up	17
4.2 Operation	17
4.3 Shutdown and storage	18
4.4 Changing from vertical to horizontal flow	18
<b>5 Maintenance</b>	<b>19</b>
5.1 Safety information	19
5.2 Exchanging the lubricants	19
5.3 Cleaning the fan cowl and the cooling fins	20
5.4 Cleaning the dirt trap	20
5.5 Cleaning the pumping chamber	21
5.6 Cleaning the valve of the pressure balance line	21
5.7 Leybold service	22
<b>6 Troubleshooting</b>	<b>23</b>

**Warning** Indicates procedures that must be strictly observed to prevent hazards to persons.



**Caution** Indicates procedures that must strictly be observed to prevent damage to, or destruction of the equipment.

**Figures**

The references to figures, e.g. (1/2) consist of the Fig. No. and the Item No. in that order.

**Leybold-Service**

If a pump is returned to Leybold, indicate whether the pump free of substances damaging to health or whether it is contaminated.

If it is contaminated also indicate the nature of the hazard. Leybold must return any pumps without a „Declaration of Contamination“ to the sender’s address.

**Disposal of waste oil**

Under the amended law relating to waste disposal dated November 1, 1986 (valid in the Federal Republic of Germany) the disposal of used oil is subject to new provisions. According to legislation relating to waste disposal the so-called principle of causality is applied. Hence, anyone in possession of used oil is responsible for its proper disposal.

Used oils coming from vacuum pumps must not be mixed with other substances.

Used oils from vacuum pumps (LH-oils on the basis of mineral oils) having been affected by normal contamination due to oxygen from the ambient air, increases in temperature and mechanical wear, must be disposed of as used oil in accordance with the regulations.

Used oils from vacuum pumps that have been contaminated by other substances must be labelled, stored and disposed of as special waste with reference to the kind of contamination.

If you send a pump to LEYBOLD for repair please indicate any harmful substances existing in the pump oil or around the pump.

When disposing of used oil please observe the safety regulations that are valid in your country.

We reserve the right to modify the design and the specified data. The illustrations are not binding.

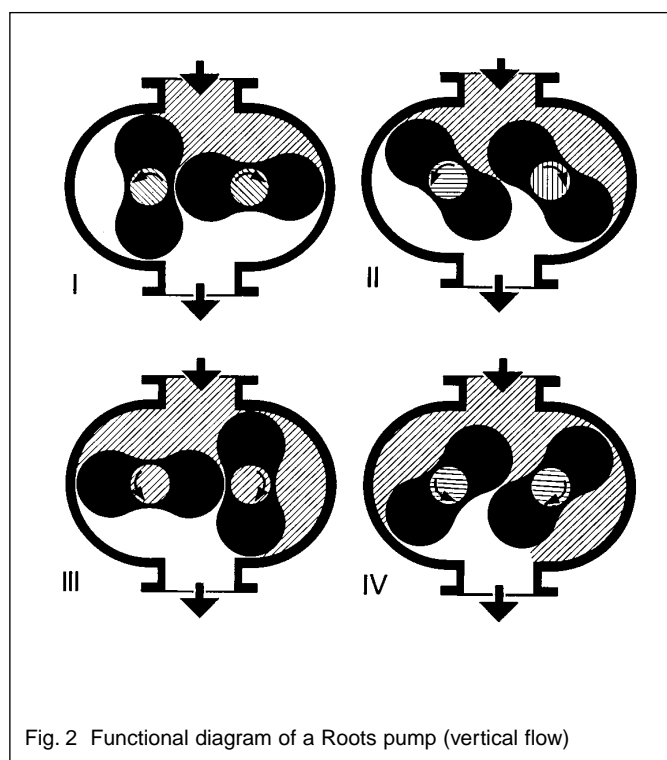
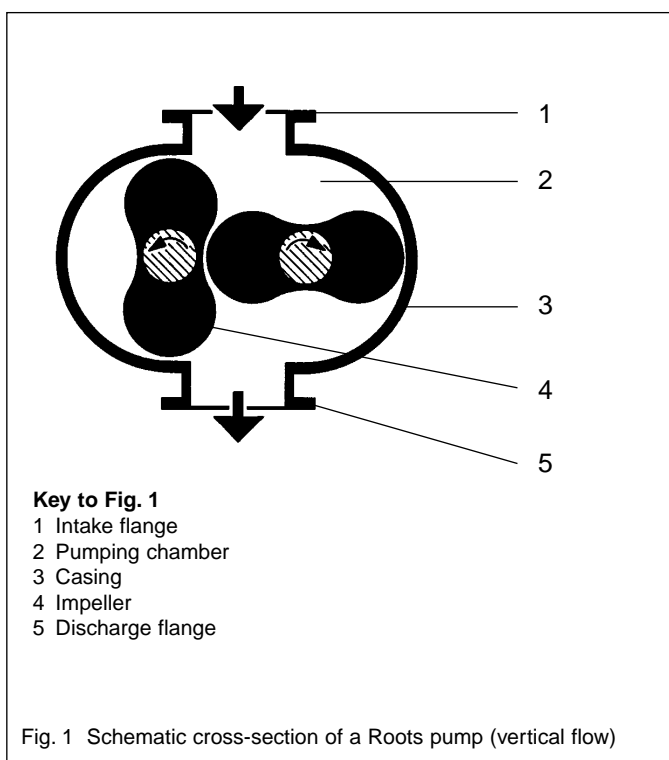

# 1 Description

## 1.1 Design and Function

The RUVAC WS and RUVAC WSU are Roots pumps driven by a canned motor.

The WSU types have a pressure balance line between the discharge and intake flanges.

The RUVAC WS and WSU are lubricated with mineral oil or perfluorized polyether (PFPE) in the case of the PFPE models. Apart from the lubricant the mineral oil and PFPE models are identical in type.

Only the RUVAC WS PFPE can be used for pumping greater than atmospheric concentrations of oxygen or very aggressive or hazardous gases.

### 1.1.1 Principle of Operation

Roots pumps - also known as Roots blowers - contain in their pump casing (1/3) two symmetrical impellers (1/4) rotating in opposite directions. The impellers have roughly the cross section of a figure „8“ and are synchronised by a toothed gearing so that they move past each other and the casing without contact but with a small clearance.

The principle of operation is explained in Fig. 2.

In impeller positions I and II, the volume in the intake flange is increased. When the impellers rotate further to position III, part of the volume is sealed off from the intake side.

In position IV, this volume is opened to the discharge side, and gas at backing pressure (higher than the intake pressure) flows in. The inflowing gas compresses the gas volume pumped from the intake side. As the impellers rotate further, the compressed gas is ejected via the discharge flange.

This process occurs twice per complete revolution of each of the two impellers.

Due to the non-contacting rotation in the pumping chamber, Roots pumps can be operated at high speeds (standard  $n = 3,000$  rpm at a mains frequency of 50 Hz). Thus a relatively high pumping speed is attained with small pumps.

The pressure differential and compression ratio between the intake and discharge sides are limited on Roots pumps. If the allowable pressure differential is exceeded, the pump overheats.

In practice, the maximum attainable pressure differential is significant only in the rough vacuum range ( $p > 10$  mbar), whereas for pressures in the fine vacuum range ( $p < 1$  mbar) the attainable compression ratio is decisive.

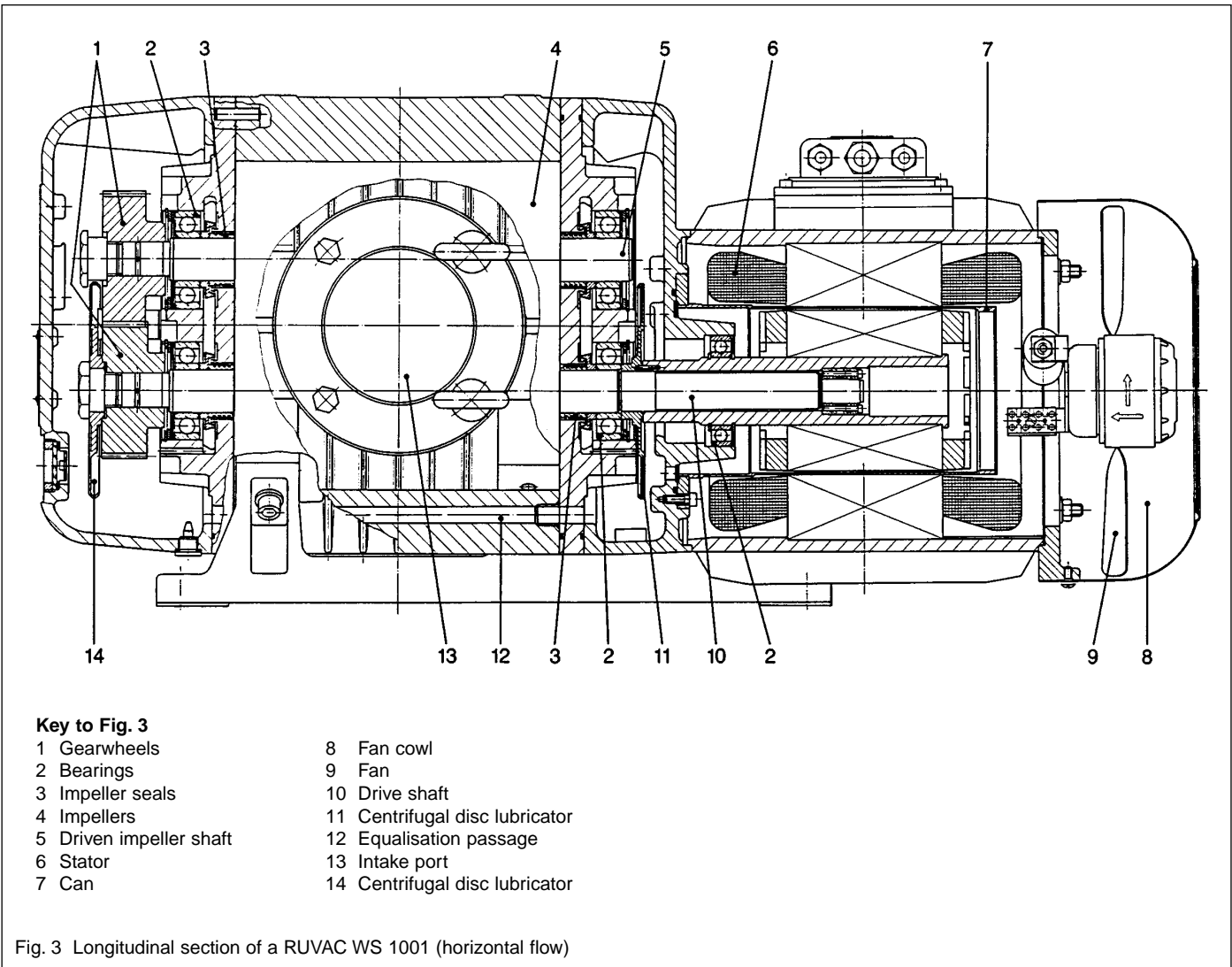

RUVAC pumps from the WS/WSU range have been specifically designed for operation in the rough and fine vacuum ranges. They are thus either used in connection with backing pumps or in closed gas cycles. The pump's power consumption depends not only on the pumping chamber volume and the rotational speed of the pump, but also on the pressure differential between the discharge and intake flanges (see Fig. 7).

### 1.1.2 Design

RUVAC Roots pumps can pump gas in the vertical or horizontal direction.

Although the pumping chamber of Roots pumps is free of sealing agents and lubricants, the two gearwheels of the synchromesh gearing (3/1) and the bearings (3/2) are lubricated with mineral oil or with PFPE. The gearwheels and bearings of the RUVAC are located in two side chambers which also contain the oil supply.

These two side chambers are separated from the pumping chamber by the impeller seals (3/3). During operation of the pump, the side chambers are evacuated via the

impeller seals.

The side chambers are linked to each other by two passages (3/12). These passages are arranged so that for either horizontal or vertical flow the pressure will be equalised between the oil supplies.

In both side chambers there are integrated oil pumps to ensure that the bearings and gearwheels receive sufficient lubricant at all recommended speeds.

RUVAC WS/WSUs are driven by a canned motor. In such a motor, the rotor and stator coils (3/6) are separated by a vacuum-tight can (3/7) made of non-magnetic material. The rotor runs in the vacuum on the pump's drive shaft (3/10); thus a shaft feedthrough to the atmosphere is not needed.

With the standard motors, the RUVAC WS/WSUs can run on either 50 Hz or 60 Hz power supplies.

For the permissible electrical connection data with respect to these frequencies, see Section 1.3.

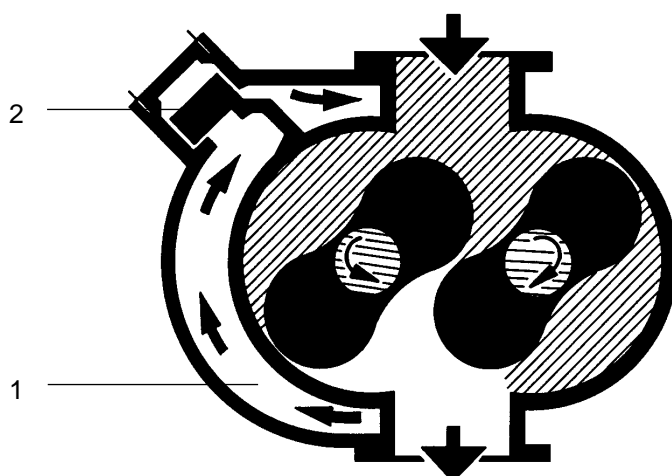

**Key to Fig. 4**  
 1 Pressure balance line  
 2 Pressure balance valve

Fig. 4 Schematic diagram of a Roots pump with pressure balance line

Incorporated in the motor's stator winding is a thermal switch which turns off the pump when the motor temperature is too high.

RUVAC WS/WSUs are air-cooled. The airflow for cooling the motor and pump is produced by a fan (3/9) with its own drive motor under the motor's fan cowl (3/8).

### 1.1.3 Pressure Balance Line

The RUVAC WSU has an integrated pressure balance line (4/1). It links the discharge and intake flanges via a pressure balance valve.

If the pressure differential between the flanges is too large, the valve opens (4/2). Some of the gas which has already been pumped then flows back through the line to the intake flange.

The valve is weight- and spring-loaded so that it works with both vertical and horizontal flow of the pump.

As a result of this pressure balance line, no additional devices are needed to protect the pump against excessive pressure differentials. The RUVAC WSU can be switched on at atmospheric pressure at the same time as a backing pump. As a result, the pumping speed of the pump combination is increased even at high intake pressures.

### 1.1.4 Lubricants

The standard RUVAC WS/WSU pumps are either ready for operation with mineral oil or with the special lubricant, perfluorized polyether (PFPE).

Other types of oil (white oil, for example) upon request.

**Caution** If mineral oil and PFPE come into contact they will emulsify. That's why the pumps must only be run with the type of lubricant specified for the pump. If you want to change the type of lubricant LEYBOLD should do the change.

In case of operation with mineral oil we recommend our vacuum pump oil N 62 (HE-200 in the USA). In case of operation with PFPE we recommend our NC 1/14 (HE1600 in the USA).

PFPE pumps are marked by an additional red label at the oil-fill screw.

The Operating Instructions GA 07.009 „PFPE for Vacuum Pumps“ will be enclosed with any RUVAC PFPE. Observe the handling notes for PFPE collected in these Operating Instructions.

### 1.1.5 Flange Connections

The cast flanges on the pump's body comply with DIN 2501, nominal pressure 6.

The pumps are supplied with different collar flanges:

Pumps with Cat. Nos. beginning with 917... are equipped with collar flanges corresponding to the ASA standard. These are intended for the American market („US version“).

Pumps with Cat. Nos. beginning with 117... are equipped with ISO-K collar flanges. This standard can be applied in all other parts of the world („Euro version“).

### 1.2 Standard Specification

RUVAC WS/WSUs are supplied for vertical flow as standard unless you specifically request horizontal flow.

Before the pump is shipped the oil has been drained out. The quantity of oil or PFPE needed for running the pump is supplied in a separate container.

Pumps with Cat. Nos. beginning with 117... are supplied with a sealing disc, a blank flange and an ISO-K collar flange fitted with the required number of screws.

Pumps with Cat. Nos. beginning with 917... are supplied with ASA adapter flanges. The ASA flanges are sealed with a piece of foil.

The intake flanges of all pumps contain a wire mesh dirt trap and have been vented with nitrogen for protection against corrosion.

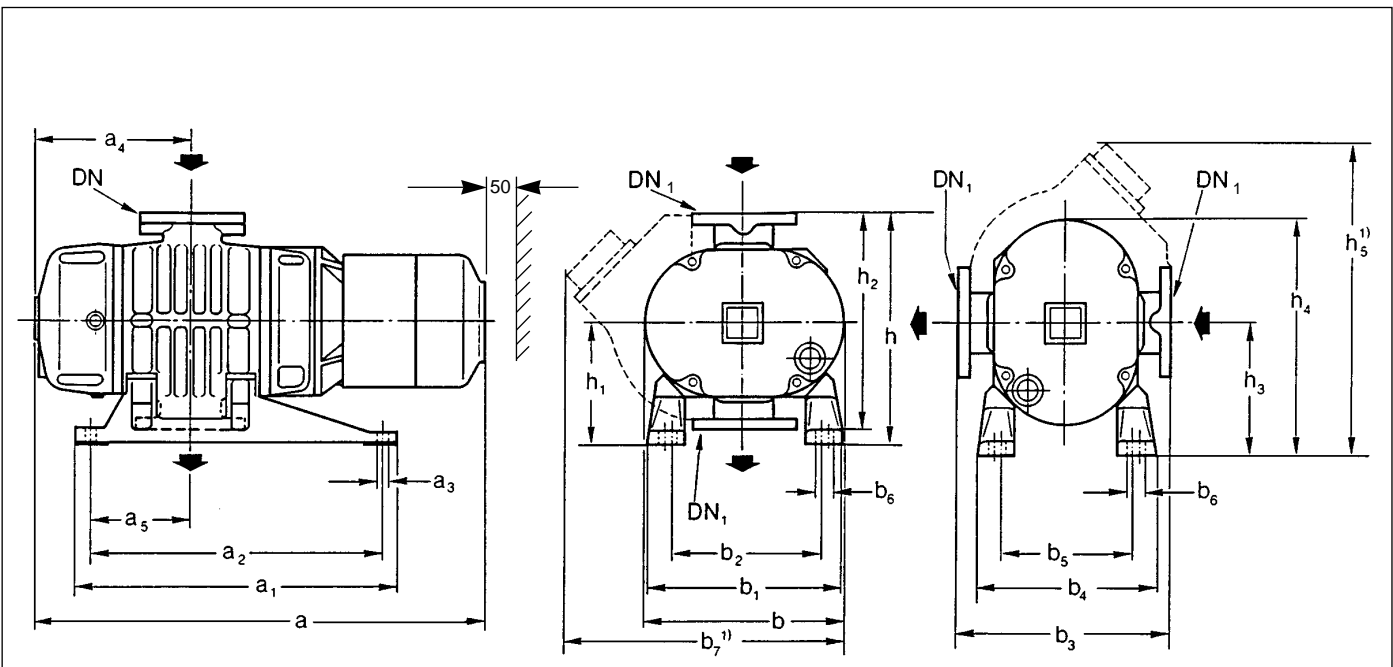

Table giving the dimensions for RUVAC WS and WSU („Euro versions“)

Type	DN	DN1 <sup>2)</sup>	a	a1	a2	a3	a4	a5	b	b1	b2	b3	b4	b5	b6	b7 <sup>1)</sup>	h	h1	h2	h3	h4	h5 <sup>1)</sup>
WS 151	63 ISO-K	65	634	400	364	14	180	97	250	280	215	280	240	175	24	-	300	160	280	180	306	-
WSU 151	63 ISO-K	65	634	400	364	14	180	97	250	288	224	280	248	184	24	305	300	160	280	180	306	360
WS/WSU 251	63 ISO-K	65	697	405	365	14	212	120	250	270	210	280	230	170	24	305	300	160	280	180	306	360
WS/WSU 501	63 ISO-K	65	745	486	450	14	239	155	307	299	229	320	271	201	24	390	340	180	320	194	348	430
WS/WSU 1001	100 ISO-K	100	887	560	520	16,5	300	180	372	352	278	370	320	246	24	490	396	211	370	227	414	532
WS/WSU2001	160 ISO-K	150	1065	800	740	18	370	220	457	518	388	460	422	292	24	635	530	300	460	351	578	753

<sup>1)</sup> On RUVAC WSU only

<sup>2)</sup> To DIN 2501, nominal pressure 6

Fig. 5 Dimensional drawing for the RUVAC WS/WSU

## 1.3 Technical Data

50 Hz operation, SI units, „Euro Versions“

RUVAC WS / WSU		151	251	501	1001	2001
Nominal pumping speed <sup>1)</sup>	m <sup>3</sup> · h <sup>-1</sup>	153	253	505	1000	2050
Maximum pumping speed (at a pumping speed for the backing pump of)	m <sup>3</sup> · h <sup>-1</sup>	130	210	450	890	1850
	m <sup>3</sup> · h <sup>-1</sup>	40	65	160	250	630
Possible cut-in pressure (RUVAC WS at a pumping speed for the backing pump of)	mbar	46	31	37	27	22
	m <sup>3</sup> · h <sup>-1</sup>	40	65	160	250	630
Maximum allowable pressure differential in continuous operation	mbar	130	80	80	80	50
Leak tightness	mbar · l · s <sup>-1</sup>	< 1 · 10 <sup>-4</sup>				
Permissible ambient temperatures (Mineral oil and PFPE)	°C	12 - 40				
Permissible voltages at the motor fan	AC	230 V / 50 Hz und 265 V / 60 Hz, 1-phase				
Mains voltage at the motor, 50 Hz	DC	230 / 400 V, 3-phase				
Motor power, 50 Hz	kW	1,1	1,1	2,2	4,0	7,5
Nominal speed, 50 Hz	min <sup>-1</sup>	3000	3000	3000	3000	3000
Max. permissible speed	min <sup>-1</sup>	6000	6000	6000	6000	4200
Motor protection category <sup>3)</sup>	IP	20	20	20	20	20
Lubricant filling	l	0,7	0,7	1,0	2,0	4,0
	l	0,5	0,5	0,7	1,2	2,0
Weight WS / WSU	kg	85 / 90	90 / 95	130 / 135	228 / 233	458 / 465
Collar flanges	DN	63 ISO - K	63 ISO - K	63 ISO - K	100 ISO - K	160 ISO - K
Noise level <sup>2)</sup>	dB (A)	< 63	< 63	< 63	< 68	< 72

### Cat. Nos.

RUVAC WS		117 12	117 22	117 32	117 42	117 52
RUVAC WSU		117 13	117 23	117 33	117 43	117 53
RUVAC WS PFPE		117 17	117 27	117 37	117 47	117 57
RUVAC WSU PFPE		-	117 28	117 38	-	-

<sup>1)</sup> as per DIN 28400 ff

<sup>2)</sup> at an operating pressure < 10-1 mbar at 1 meter distance

<sup>3)</sup> IP is an international standard that identifies the level of protection against dust, contact and water

### Voltage ranges for the canned motors of the RUVAC WS/WSU pumps

Pump model	Nominal power / Nominal current at 50 Hz						Nominal power / Nominal current at 60 Hz					
	200 V		230 V		400 V		200-208 V		265 V		460 V	
	KW	A	KW	A	KW	A	KW	A	KW	A	KW	A
WS 151/251 WSU 151/251 WS/WSU PFPE 151/251	0,9	4,8	1,1	5,5	1,1	3,2	0,9	4,8	1,4	5,5	1,4	3,2
WS 501 WSU 501 WS/WSU PFPE 501	1,6	7,8	2,2	9	2,2	5,4	1,6	7,8	2,4	10	2,4	5,8
WS 1001 WSU 1001 WS PFPE 1001	3	13	4	15,7	4	9,1	3	13	4,4	14,7	4,4	8,5
WS 2001 WSU 2001 WS PFPE 2001	5	21	7,5	26	7,5	15	5	21	8,5	26	8,5	15

**Caution** The motor overload protection switch must be set to the nominal current stated in the table in each case. The separate fan current may only be operated within the permissible voltage range (230 V, 50 Hz and 265 V, 60 Hz). In the case of deviating voltages you must use a transformer.

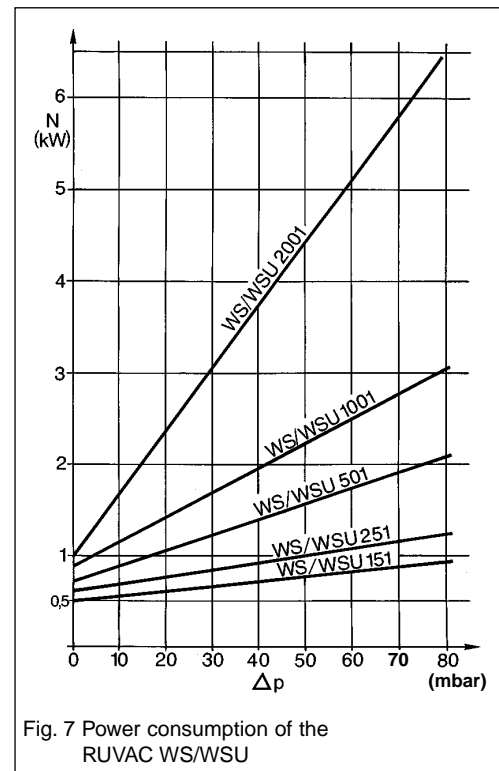
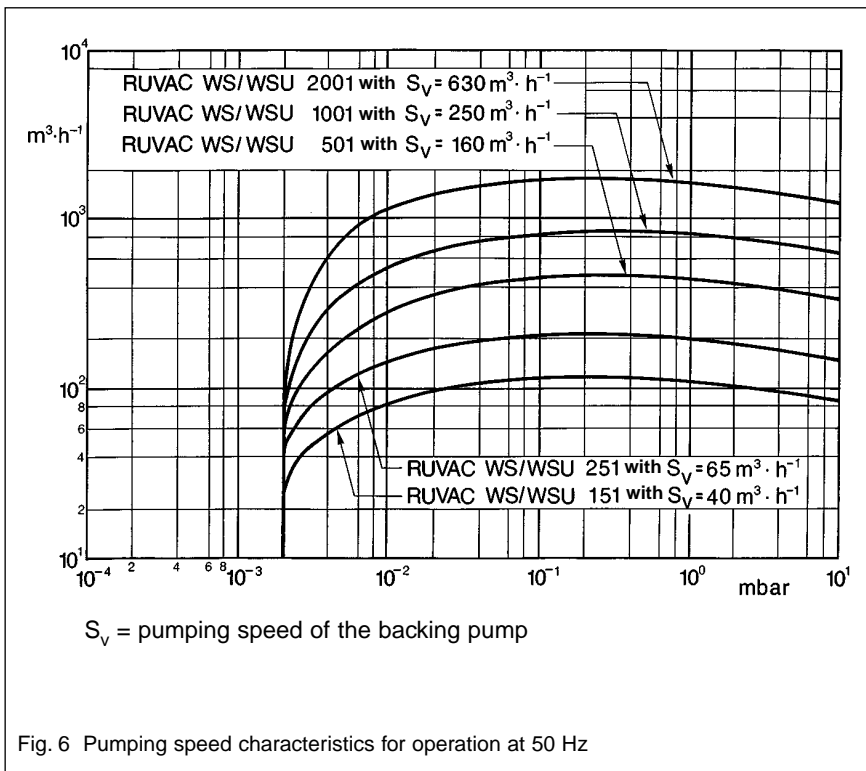



# For US-Versions

## Conversion of Units

Conversion factors	Different pressure units			Different pumping speed units		
	mbar (millibar)	torr	Inches Hg vacuum	$m^3 \cdot h^{-1}$ $m^3 \cdot h^{-1} = m^3/h$	$l \cdot s^{-1}$ $l \cdot s^{-1} = l/s$	cfm (cubic feet per minute)
1 lb = 0.453 kg	1013	760	0	1	0.278	0.589
1 qt = 0.946 l	400	300	18.12	3.60	1	12.12
1 hp = 0.735 kW	133	100	25.98	1.699	0.472	1
1 rpm = 1 min <sup>-1</sup>	4	3	29.80			
1 inch = 25.4 mm	1	0.75	29.89			
	0	0	29.92			

1 atm (atmosphere) = 1013 bar  
 1 Pa (pascal) = 0.01 bar = 10<sup>-2</sup> mbar  
 1 bar = 1000 mbar

Example: 1 m<sup>3</sup> h<sup>-1</sup> = 0.589 cfm  
 Note: The nominal pumping speed of a pump at 60 Hz is 20 % higher than at 50 Hz.

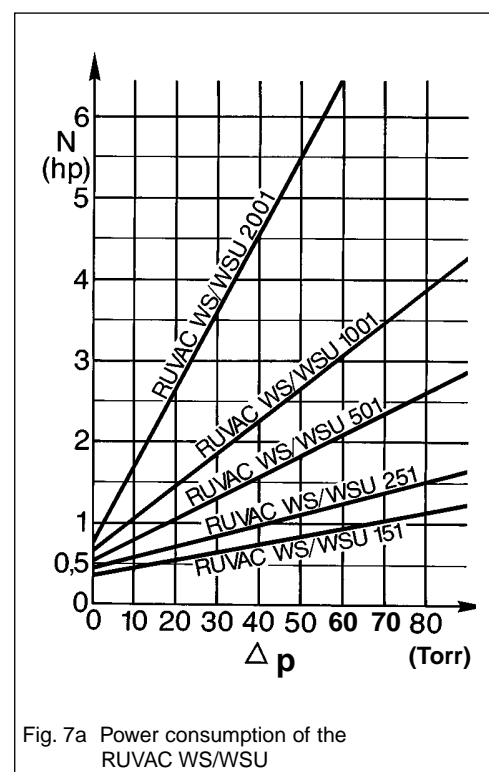
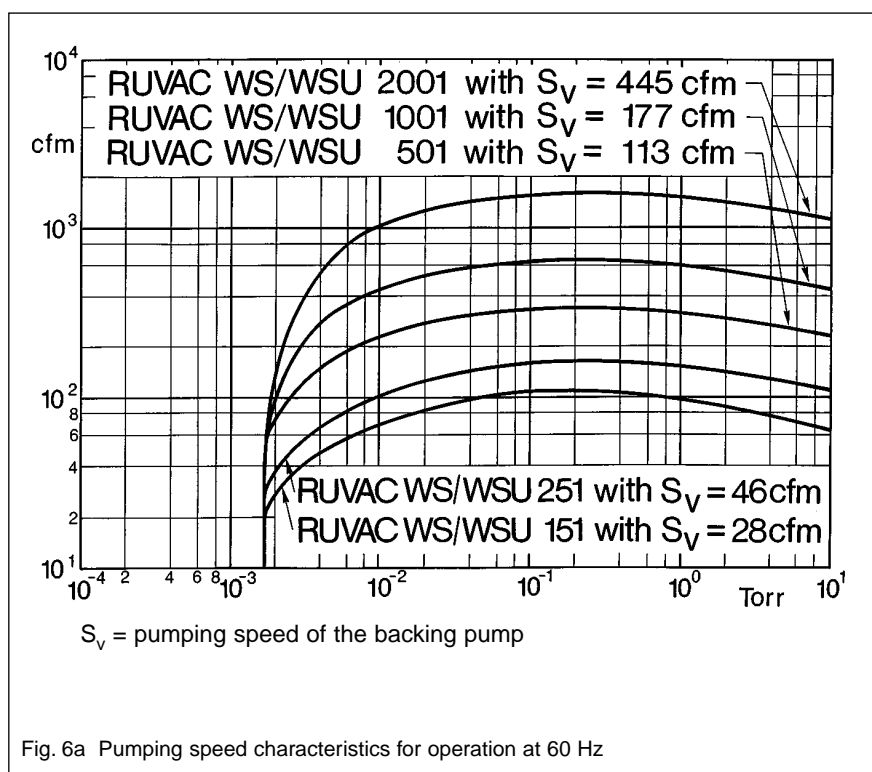

# Technical Data

60 Hz-operation, English units, „US-Versions“; further technical Data see „Euro-Versions, page 7.

RUVAC WS / WSU		151	251	501	1001	2001
Nominal pumping speed	cfm	108	179	357	707	1449
Maximum pumping speed at backing pump speed	cfm	92	148	318	629	1308
	cfm	28	46	113	177	445
Possible switch in ressure RUVAC WS at backing pump speed	Torr	35	23	28	20	16
	cfm	28	46	113	177	445
Maximum allowable pressure differential in continuous operation	Torr	98	60	60	60	38
Supply voltage, 60 Hz	DC	208-230/460 V, 3-phase				
Motor power, 60 Hz	HP	1.5	1.5	2.9	5.3	10.2
Ratet rotational speed of pump, 60 Hz	rpm	3600	3600	3600	3600	3600
Max. possible rotational speed	rpm	6000	6000	6000	6000	4200
Oil charge for vertical pump flow for horizontal pump flow	qt	.75	.75	1.1	2.1	4.2
	qt	.55	.55	.75	1.3	2.1
Weight WS/WSU	lbs	188/199	199/210	287/298	503/514	1011/1026
Connecting flanges	ANSI	3"	3"	3"	4"	6"
Permissible ambient temperatures	°F	54 - 104				

**Ref.-No.**

RUVAC WS		917 12	917 22	917 32	917 42	917 52
RUVAC WSU		917 13	917 23	917 33	917 43	917 53
RUVAC WS PFPE		917 17*	917 27*	917 37	917 47	-
RUVAC WSU PFPE		917 18	917 28	917 38	917 48	-

\*) WS-PFPE pumps without feed are available under Cat. Nos. **917 19** and **917 29**. These may be flanged directly on to the backing pumps.  
The terminal boards for the motors of these models are ready for „low voltage“.

## Dimensions in inches for RUVAC WS and WSU (US-Versions)

Type	DN	DN1 <sup>2)</sup>	a	a1	a2	a3	a4	a5	a6	b	b1	b2	b3
WS 151	3" ASA	65	24 <sup>31</sup> / <sub>32</sub>	15 <sup>3</sup> / <sub>4</sub>	14 <sup>11</sup> / <sub>32</sub>	1 <sup>7</sup> / <sub>32</sub>	7 <sup>3</sup> / <sub>32</sub>	3 <sup>13</sup> / <sub>16</sub>	2	9 <sup>27</sup> / <sub>32</sub>	11 <sup>1</sup> / <sub>32</sub>	8 <sup>15</sup> / <sub>32</sub>	11
WSU 151	3" ASA	65	24 <sup>31</sup> / <sub>32</sub>	15 <sup>3</sup> / <sub>4</sub>	14 <sup>11</sup> / <sub>32</sub>	1 <sup>7</sup> / <sub>32</sub>	7 <sup>3</sup> / <sub>32</sub>	3 <sup>13</sup> / <sub>16</sub>	2	9 <sup>27</sup> / <sub>32</sub>	11 <sup>1</sup> / <sub>32</sub>	8 <sup>27</sup> / <sub>32</sub>	11
WS/WSU 251	3" ASA	65	27 <sup>15</sup> / <sub>32</sub>	15 <sup>15</sup> / <sub>16</sub>	14 <sup>3</sup> / <sub>88</sub>	1 <sup>7</sup> / <sub>32</sub>	8 <sup>11</sup> / <sub>32</sub>	4 <sup>23</sup> / <sub>32</sub>	2	9 <sup>27</sup> / <sub>32</sub>	10 <sup>5</sup> / <sub>8</sub>	8 <sup>9</sup> / <sub>32</sub>	11
WS/WSU 501	3" ASA	65	29 <sup>11</sup> / <sub>32</sub>	19 <sup>1</sup> / <sub>8</sub>	17 <sup>23</sup> / <sub>32</sub>	1 <sup>7</sup> / <sub>32</sub>	9 <sup>13</sup> / <sub>32</sub>	6 <sup>3</sup> / <sub>32</sub>	2	12 <sup>3</sup> / <sub>32</sub>	11 <sup>25</sup> / <sub>32</sub>	9	12 <sup>19</sup> / <sub>32</sub>
WS/WSU 1001	4" ASA	100	34 <sup>15</sup> / <sub>16</sub>	22 <sup>1</sup> / <sub>16</sub>	20 <sup>16</sup> / <sub>32</sub>	2 <sup>1</sup> / <sub>32</sub>	11 <sup>13</sup> / <sub>16</sub>	7 <sup>3</sup> / <sub>32</sub>	2	14 <sup>21</sup> / <sub>32</sub>	13 <sup>7</sup> / <sub>8</sub>	10 <sup>31</sup> / <sub>32</sub>	14 <sup>9</sup> / <sub>16</sub>
WS/WSU 2001	6" ASA	150	43 <sup>11</sup> / <sub>16</sub>	31 <sup>1</sup> / <sub>2</sub>	29 <sup>5</sup> / <sub>32</sub>	1 <sup>1</sup> / <sub>16</sub>	14 <sup>17</sup> / <sub>32</sub>	8 <sup>21</sup> / <sub>32</sub>	2	18	20 <sup>13</sup> / <sub>32</sub>	15 <sup>3</sup> / <sub>8</sub>	18 <sup>1</sup> / <sub>8</sub>

Type	b4	b5	b6	b7 <sup>1)</sup>	h	h1	h2	h3	h4	h5 <sup>1)</sup>
WS 151	9 <sup>15</sup> / <sub>32</sub>	6 <sup>29</sup> / <sub>32</sub>	15 <sup>1</sup> / <sub>16</sub>	-	11 <sup>13</sup> / <sub>16</sub>	6 <sup>5</sup> / <sub>16</sub>	11 <sup>1</sup> / <sub>32</sub>	7 <sup>3</sup> / <sub>32</sub>	12 <sup>1</sup> / <sub>6</sub>	-
WSU 151	9 <sup>25</sup> / <sub>32</sub>	7 <sup>1</sup> / <sub>4</sub>	15 <sup>1</sup> / <sub>16</sub>	12	11 <sup>13</sup> / <sub>16</sub>	6 <sup>5</sup> / <sub>16</sub>	11 <sup>1</sup> / <sub>32</sub>	7 <sup>3</sup> / <sub>32</sub>	12 <sup>1</sup> / <sub>6</sub>	14 <sup>3</sup> / <sub>16</sub>
WS/WSU 251	9 <sup>1</sup> / <sub>16</sub>	6 <sup>1</sup> / <sub>16</sub>	15 <sup>1</sup> / <sub>16</sub>	12	11 <sup>13</sup> / <sub>16</sub>	6 <sup>5</sup> / <sub>16</sub>	11 <sup>1</sup> / <sub>32</sub>	7 <sup>3</sup> / <sub>32</sub>	12 <sup>1</sup> / <sub>16</sub>	14 <sup>3</sup> / <sub>16</sub>
WS/WSU 501	10 <sup>21</sup> / <sub>32</sub>	7 <sup>29</sup> / <sub>32</sub>	15 <sup>1</sup> / <sub>16</sub>	15 <sup>1</sup> / <sub>32</sub>	13 <sup>3</sup> / <sub>8</sub>	7 <sup>3</sup> / <sub>32</sub>	12 <sup>19</sup> / <sub>32</sub>	7 <sup>5</sup> / <sub>8</sub>	13 <sup>23</sup> / <sub>32</sub>	16 <sup>15</sup> / <sub>16</sub>
WS/WSU 1001	12 <sup>19</sup> / <sub>32</sub>	9 <sup>11</sup> / <sub>16</sub>	15 <sup>1</sup> / <sub>16</sub>	19 <sup>5</sup> / <sub>16</sub>	15 <sup>19</sup> / <sub>32</sub>	8 <sup>5</sup> / <sub>16</sub>	14 <sup>9</sup> / <sub>16</sub>	8 <sup>15</sup> / <sub>16</sub>	16 <sup>5</sup> / <sub>16</sub>	20 <sup>15</sup> / <sub>16</sub>
WS/WSU2001	16 <sup>5</sup> / <sub>8</sub>	11 <sup>1</sup> / <sub>2</sub>	29 <sup>1</sup> / <sub>32</sub>	25	20 <sup>7</sup> / <sub>8</sub>	11 <sup>13</sup> / <sub>16</sub>	18 <sup>1</sup> / <sub>8</sub>	13 <sup>13</sup> / <sub>16</sub>	22 <sup>3</sup> / <sub>4</sub>	29 <sup>21</sup> / <sub>32</sub>

<sup>1)</sup> for RUVAC WSU only

<sup>2)</sup> according to DIN 2501, ND 6 (in metric system)

## 1.4 Accessories

	Cat.-No.
<b>Set of gaskets</b>	
WS/WSU 151/251 .....	194 62
WS/WSU 501 .....	194 66
WS/WSU 1001 .....	194 70
WS/WSU 2001 .....	194 74
<b>Oil pressure switches</b> .....	194 82
(for WS-PFPE models only)	
<b>Oil drain facility (M 16 x 1.5)</b>	
- with straight drain coupling .....	190 02
- with right-angled drain coupling .....	200 14 271
<b>Diaphragm pressure switch SM 42</b>	
0,5 to 6 mbar .....	164 05
5 to 50 mbar .....	164 06
40 to 400 mbar .....	164 07
<b>Accessories for mounting SM 42</b>	
Adapter .....	168 39
Right-angle bend DN 20 KF .....	184 32
Centering ring DN 20 KF, 2x .....	183 22
Clamping ring DN 20 KF, 2 x .....	183 42
<b>Pressure switch PS 114 (stainless steel)</b> ....	160 01
<b>Pressure switch PS 115 (stainless steel)</b> ....	160 04
<b>Accessories for mounting PS 114/115</b>	
Adapter .....	168 40
Right-angle bend DN 16 KF .....	184 36
Centering ring DN 16 KF, 2 x .....	183 26
Clamping ring DN 16 KF, 2x .....	183 41
<b>Contact amplifier SV 110</b>	
- 220 V .....	160 78
<b>Öl N 62*</b> ,5l .....	177 02
<b>Öl HE-200*</b> ,1 gal .....	.98-198-007
<b>PFPE NC 1/14</b> ,1l .....	177 38
<b>PFPE HE-1600</b> ,2 lb .....	.898 564-1

\* N 62 is an oil grade of LH Cologne, and HE-200 is an oil grade of LHVP Export. They are interchangeable. For other quantities, see catalogue. This applies similarly also to NC 1/14 and HE-1600.

## 2 Transportation and Storage

Roots pumps are heavy machines (> 70 kg) made of cast iron and thus should only be lifted using suitable lifting equipment tied to the eye (8/3) provided for this purpose.

**Caution** Before transporting the pump always drain out the oil (see Section 5.2). Screw the oil-drain plug with its gasket back in and wipe any oil droplets off from the casing.

The pump should be transported and stored in a horizontal position (5° max. tilt with respect to its longitudinal axis). Otherwise there is the danger that oil from the side chambers may enter the pump chamber, even before the pump is filled with oil for the first time.

**Caution** When shelving the pump for a longer period of time you should seal off the flanges of the pump with a piece of foil or the cardboard discs initially supplied with the pump using the collars. Place a bag with desiccant in the pump chamber, if required.

Pumps having a filling of PFPE should be sealed off in a gas-tight manner and vented with nitrogen.

The area of the motor (fan and slits at the flange of the motor) must be protected against dust and dripping water.

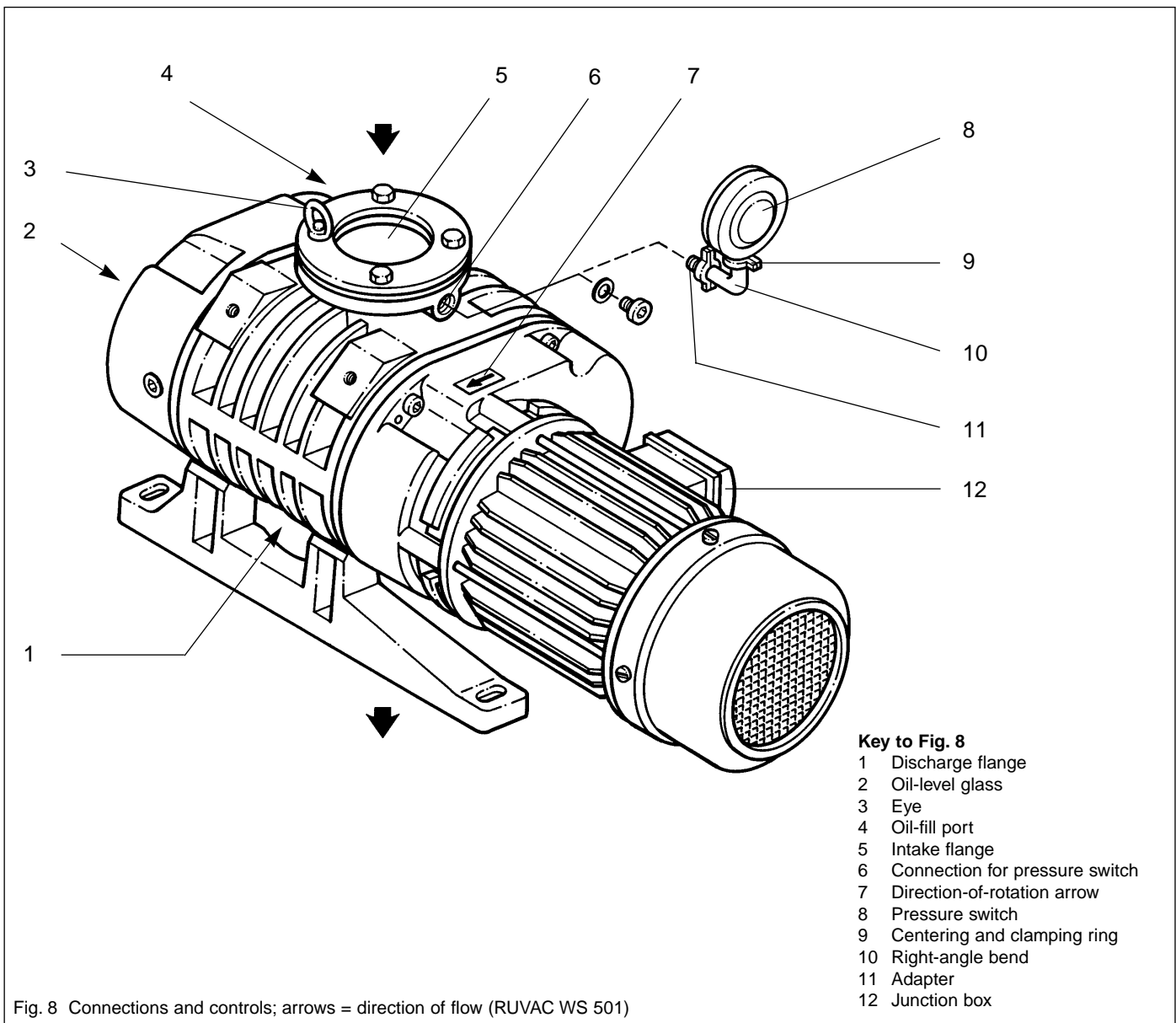

Fig. 8 Connections and controls; arrows = direction of flow (RUVAC WS 501)

## 3 Installation and Connection

**Caution** Only fill in the oil after having installed the pump.

In the case of the RUVAC WS PFPE also observe the additional information provided in Operating Instructions GA 07.009.

### 3.1 Installation

Install RUVAC WS/WSU pumps on a flat, horizontal surface (5° max. tilt).

If the pump is not level, lubricant may enter the pumping chamber from the gear chambers.

Keep the air intake and exhaust ducts for cooling the motor unobstructed (for minimum clearance with respect to the fan cowl, see Fig. 5).

The pump's ambient temperature should be between 12 °C and 40 °C . Lower temperatures hamper run-up; higher ones shorten the lubricant change intervals and may lead to greater wear.

Special oil for operation at temperatures below 12 °C is available upon request.

**Caution** Install the WS/WSU pumps only in rooms with a roof. Motor and fan cowl are rated as IP 20 and are thus not protected against drip water and condensing water.

Secure the pump. Four bores in the feet are provided for this purpose.

**Caution** When bolting the feet down, make certain that there is no stress or twist on the pump casing. Stress on the pump can change the close tolerances between the impellers and the pump casing and may result in damage to the pump (use washers to equalise).

**Warning** Since compensation elements must be attached to the flanges on the suction and pressure sides, the screws for attachment of the feet must always be fitted and tightened.



Use the following screws:

RUVAC 151/251/501: 4 x M 12  
RUVAC 1001/2001: 4 x M 16

### 3.2 Filling in of the Lubricants

The lubricant needed for running the pump is supplied in a separate container.

Unscrew the oil-fill plug (10/3) and add lubricant.

An oil without additives and of viscosity class ISO VG 100 (formerly SAE 30) must be used for the pump. We recommend our special oils N 62 or HE-200. As PFPE we recommend our NC 1/14 or HE-1600. Please consult us if you intend to run the pump with other oils or special lubricants.

For vertical flow of the pump, the correct oil level is in the center, and for horizontal flow it is 6 mm above the center of the oil-level glass (10/1) when the pump is not running.

**Caution** If the oil level is too low, the bearings and gearwheels are not lubricated adequately; if it is too high oil may enter the pumping chamber.

Clean the oil-fill port and screw the plug back in using a gasket which is in perfect condition.

The oil-fill port must be sealed air-tight. Entry of air from the outside may cause oil-containing gas to enter the pumping chamber via the impellers seals.

### 3.3 Electrical Connections

**Warning** Disconnect the mains before doing work on the wiring.



Electrical connections must be made by a skilled electrician as defined by VDE 0105 and in accordance with the guidelines of VDE 0100.



For proper connection, a suitable motor protection switch must be used. Set the switch in accordance with the rating on the motor nameplate.

The pumps of the RUVAC WS/WSU series may also be operated by a frequency converter. For maximum speeds, refer to Section 1.3.

Please note, that at increased speeds and at the available maximum power, the max. permissible pressure difference (see Section 1.3) is no longer obtained.

Always provide an uninterrupted connection for the protective ground conductor connecting it in a professional manner. Never leave the protective ground conductor for the pump unconnected.

Connect the pump to the correct mains voltage through the terminals provided in the junction box (see Fig. 9).

Do not link control circuits to the power circuit of the motor. Observe the wiring diagrams of Fig. 9.

**Caution** When connecting the motor you must also connect the thermal switch of the pump motor and the fan motor (for recommendations, see Fig. 9).

After connecting the motor and every time you alter the wiring, check the direction of rotation.

Never allow the pump to run in the wrong direction or with open flanges for a longer period of time.

An arrow (8/7) on the motor flange shows the correct direction of rotation for the impeller connected to the motor shaft. To check rotation, switch on the motor briefly and observe the direction of impeller rotation through the pump's intake and then immediately switch off again.

**Warning** Wear protective goggles for protection against particles which may be forced out of the flange opening. Keep your hands away from the flange opening.



The impellers should move up from the center and drop down to the side.

If this is not the case, disconnect the pump from the mains and interchange two mains phases.

Even if the pump has been already firmly connected to the piping, you may determine the direction of rotation.

For this, evacuate the vacuum system down to a pressure below 20 mbar with the aid of the backing pump. Then switch on the RUVAC briefly; now the pressure must drop. If the pressure increases or remains constant, the RUVAC is turning in the wrong direction.

Then rewire as described above.

**Caution** The built-in fan is driven by a separate single-phase motor and may thus not be used to determine the direction of rotation of the pump.

Its direction of rotation is independent of the pump and doesn't change when you interchange the phases.

The fan may only be operated with 230/265 V, 50/60 Hz. If the pump is operated at other voltages or higher frequencies to obtain higher speeds, connect the fan separately to a power supply. In the case of deviating voltages use a transformer.

If a mains voltage of 230 V/50 Hz or 265 V/60 Hz single-phase is not available, connect the fan motor between 2 conductors.

The RUVAC can be automatically switched on and off via a contactor using a pressure switch and the contact amplifier SV 110 (see Section 1.4).

The pressure switches SM 42 or PS 114 are set to a fixed threshold in our factory. Please specify the switching threshold when ordering.

The threshold of pressure switch PS 115 is freely adjustable.

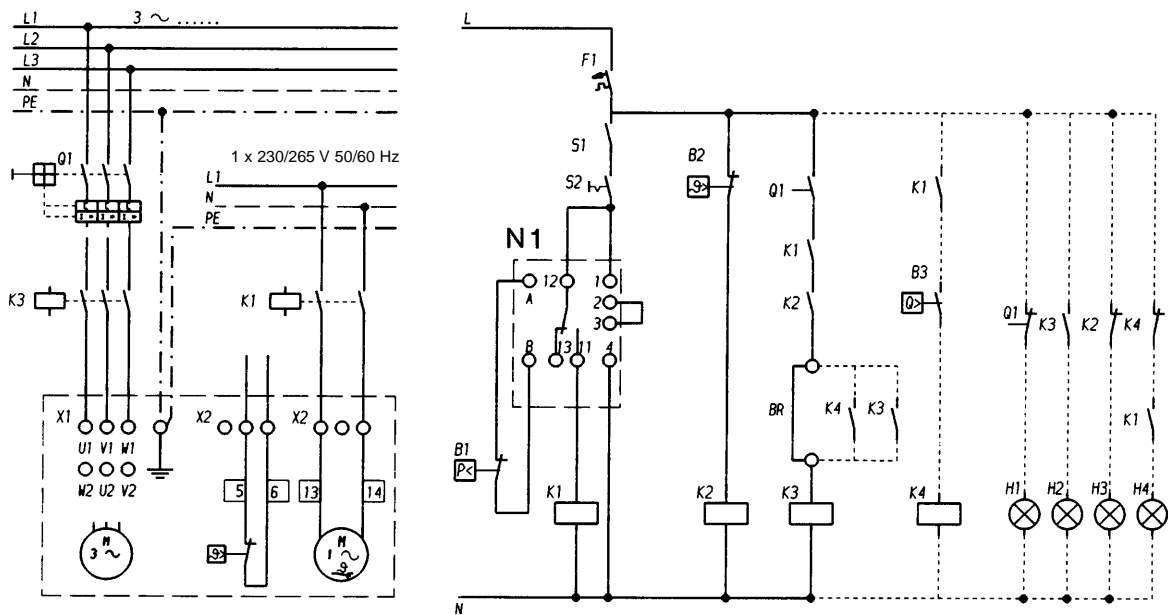

Various connection options for different mains power supplies.

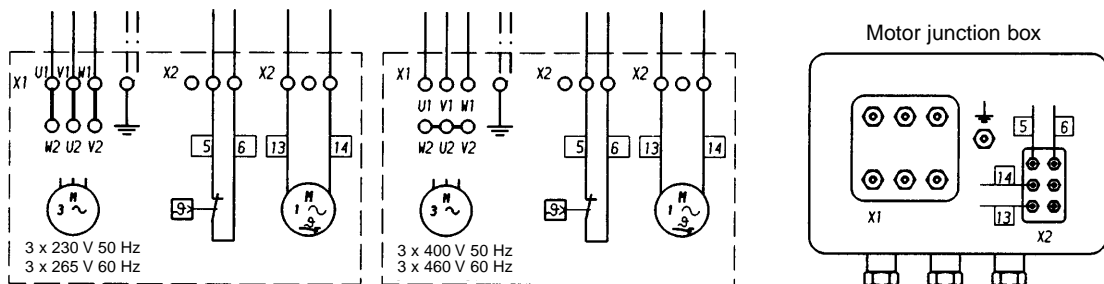

**Key to Fig. 9**

- B1 Pressure switch PS 114
- B2 Limit switch, coil temperature
- B3 Flow monitor (fan)
- K1 Relay for fan motor
- K2 Relay for temperature monitor
- K3 Relay for Roots pump motor
- K4 Relay for fan monitor
- N1 Contact amplifier SV 110 (220 V - 240 V, 50/60 Hz, 110 - 130 V, 50/60 Hz)
- S1 External switch contact
- S2 Switch contact
- F1 Fuse, control circuit
- Q1 Motor protection switch

**Signal lamps**

- H1 Motor protection switch: OFF
- H2 Roots pump: ON
- H3 Coil temperature: TOO HIGH
- H4 Cooling air: BELOW MINIMUM

**Links**

BR on extension : - - remove link

**Note**

The above control circuit is designed so that the Roots pump cuts in only if the pressure drops below the set pressure level (B1).

Fig. 9 Electrical connection

The contact amplifier is identical for all pressure switches.

Pressure switches and contact amplifiers with explosion hazard protection are available upon request.

After removing a screw plug, the pressure switch (8/8) together with an adapter (8/11) and a right-angle bend (8/10) can be mounted on the bore (8/6).

When doing so, ensure proper sealing and air-tight installation.

It is advisable to mount the switch vertically to reduce the entry of contaminants.

### 3.4 Connection of the Flanges

**Caution** Already small quantities of liquids (from the vacuum chamber or the piping) can lead to liquid damages within the pump. These may lead to a deformation of the impellers and may entirely destroy the pump. Suitable protective measures should be provided as required in the piping on the suction side (separator, T-piece).

#### Warning



The RUVAC WS/WSU pumps have not been designed to pump ignitable or explosive mixtures without additional protection. If the pumps are none-the-less to be used under such conditions, the customer himself must ensure that proper measures for the purpose of protection against explosions (pressure monitor, flame arresters etc.) are introduced in line with the requirements of the applicable laws. Explosion protected canned motors (temperature class T 3 or T 4) are not available. Consult us for advice.

**Caution** The RUVAC WS PFPE is vented with nitrogen. Only remove the packing flanges before immediate connection.

If not already done, remove the protective shipping covers, cardboard pieces, foil or packing flanges from the flanges (8/5) and (8/1).

We recommend that you retain the transport flanges of the WS PFPE in case you want to store the pump at a later date.

Clean the flanges and check that the sealing surfaces are in perfect condition.

Flange the pump to the vacuum system.

**Caution** Don't place any stress on the pump casing when installing the intake and exhaust lines. Fit compensation elements in order to avoid such stresses.

When attaching the pump directly (without bolting down the feet) to the forevacuum pump, you must always use on the pressure side the full number of screws defined by the flange standard (ISO-K, DIN or ASA) whereby these must comply with the demanded property class rating.

You must also check whether the backing pump is rigid and stable enough to support the load of the RUVAC pump in each case.

The dirt-trap which is supplied with the pump should always be fitted into the intake flange when there is the possibility of contaminants entering the pump coming from the vacuum chamber or the piping. Even with clean vacuum processes, contaminants from the system may enter upon initial start-up. Depending on the operating conditions, the dirt trap may reduce the pumping speed of the pump.

Observe the maintenance information provided in Section 5.1.



## 4 Operation

### 4.1 Start-up

Check the pump motor's direction of rotation (see Section 3.3).

#### RUVAC WSU

The RUVAC WSU can be started together with the backing pump at atmospheric pressure.

It is protected against excessively high pressure differentials by a bypass line.

#### RUVAC WS

Do not switch on the RUVAC WS until the backing pump has evacuated the vacuum vessel to the cut-in pressure.

For processes in which condensable vapours are pumped, it is advisable to evacuate the vacuum vessel via a roughing line to the cut-in pressure. Electrically switch on the Roots pump together with the backing pump and cut it in upon reaching the cut-in pressure. The initial bypassing of the Roots pump serves to prevent condensation of vapours in the cold pump.

The permissible cut-in pressure depends on the ratio between the Roots pump and the backing pump. It can be calculated according to the following formula:

$$p_E = \frac{p_{\max}}{k_{\text{th}} - 1}$$

$p_E$  = Cut-in pressure

$p_{\max}$  = Maximum permissible pressure differential (see technical data)

$k_{\text{th}}$  = Theoretical compression ratio  
= nominal pumping speed of Roots pump / pumping speed of backing pump.

Example:

Pump combination:

RUVAC WS 501 / SOGEVAC SV 100

$$k_{\text{th}} = \frac{505 \text{ m}^3 \cdot \text{h}^{-1}}{100 \text{ m}^3 \cdot \text{h}^{-1}} \sim 5$$

$$p_E = \frac{80 \text{ mbar}}{5 - 1} = 20 \text{ mbar}$$

With small vacuum vessels, the maximum permissible pressure differential can be briefly exceeded (max. 3 min) upon start-up. If a pressure switch has been installed, do not set it to this higher pressure because it will fail to protect the pump against overload in the event of a greater gas quantity.

It is advisable to switch the RUVAC WS on and off via a pressure switch to ensure that it runs only in the permissible pressure range.

### 4.2 Operation

**Warning** Do not operate the pump without having connected the flanges to a vacuum system. The screws of the flanges on the suction and the pressure side must not be loosened in the presence of a vacuum or while the pump is still running.



During operation of the RUVAC, check the lubricant level from time to time and also the condition of the lubricant. Correct as required (see Section 5/2). Normally, the oil N 62 or HE-200 is light-brown. If it turns dark, this is a sign of early ageing due to excessively high temperatures. When using PFPE as intended, PFPE will not be subject to ageing.

**Caution** Run the Roots pump exclusively under the operating conditions for which it has been designed. Any modification of the operating parameters (e. g. intake pressure, intake temperature, ratio between Roots pump and backing pump) for a longer period may place an inadmissible thermal load on the pump. Increases in temperature which are not compensated by taking suitable measures may damage the Roots pump and/or the backing pump.

**Warning** During normal operation temperatures exceeding 80 °C may occur at the oil chambers and at the line on the pressure side. When touching these there is the danger of receiving burns. Note the labels on the pump. Never open the oil-fill or oil-drain screw (Fig. 10) in the presence of a vacuum or while the pump is running. There is the danger that oil may squirt out.



### 4.3 Shutdown and Storage

**Caution** We recommend to keep the RUVAC WS with a PFPE filling running even during prolonged intervals (e. g. over night) with the intake line closed. This can help to avoid corrosion during standstill.

Close the valve between the Roots pump and the vacuum system. First switch off the Roots pump, then the backing pump.

After working with corrosive gases, the system should be vented with dry protective gas (e.g. N<sub>2</sub>) to prevent corrosion during standstill.

When shutting down the pump and removing it from the system, it is advisable to seal the connecting flanges tightly.

**Warning** Before removing pump from the vacuum system, disconnect it from the mains supply.



Before removing the RUVAC WS PFPE from the system it must be purged with nitrogen and sealed in a gas-tight manner.

For transportation and storing of the pump, observe the information provided in Section 2.

### 4.4 Changing from Vertical to Horizontal Flow

The RUVAC WS/WSUs are supplied as standard for vertical flow unless you specifically request horizontal flow. Moreover, the pump may be converted from one flow direction to the other.

For this proceed as follows:

Drain the lubricant (10/2) or (10/4) and tightly screw the oil-drain plug back in. Remove the feet, turn the pump by 90° as shown in Fig. 5 (dimensional drawing) and mount the feet for the new direction of flow.

**Caution** The longitudinal axis of the pump must remain horizontal so that no residual lubricant can flow from the side chambers into the pumping chamber.

Fill in lubricant (10/3); (see Section 3.2).

If a pressure switch has been installed, turn it so that it again points vertically upwards.

The valve in the pressure balance line of the RUVAC WSU is designed to work with both vertical and horizontal flow of the pump.

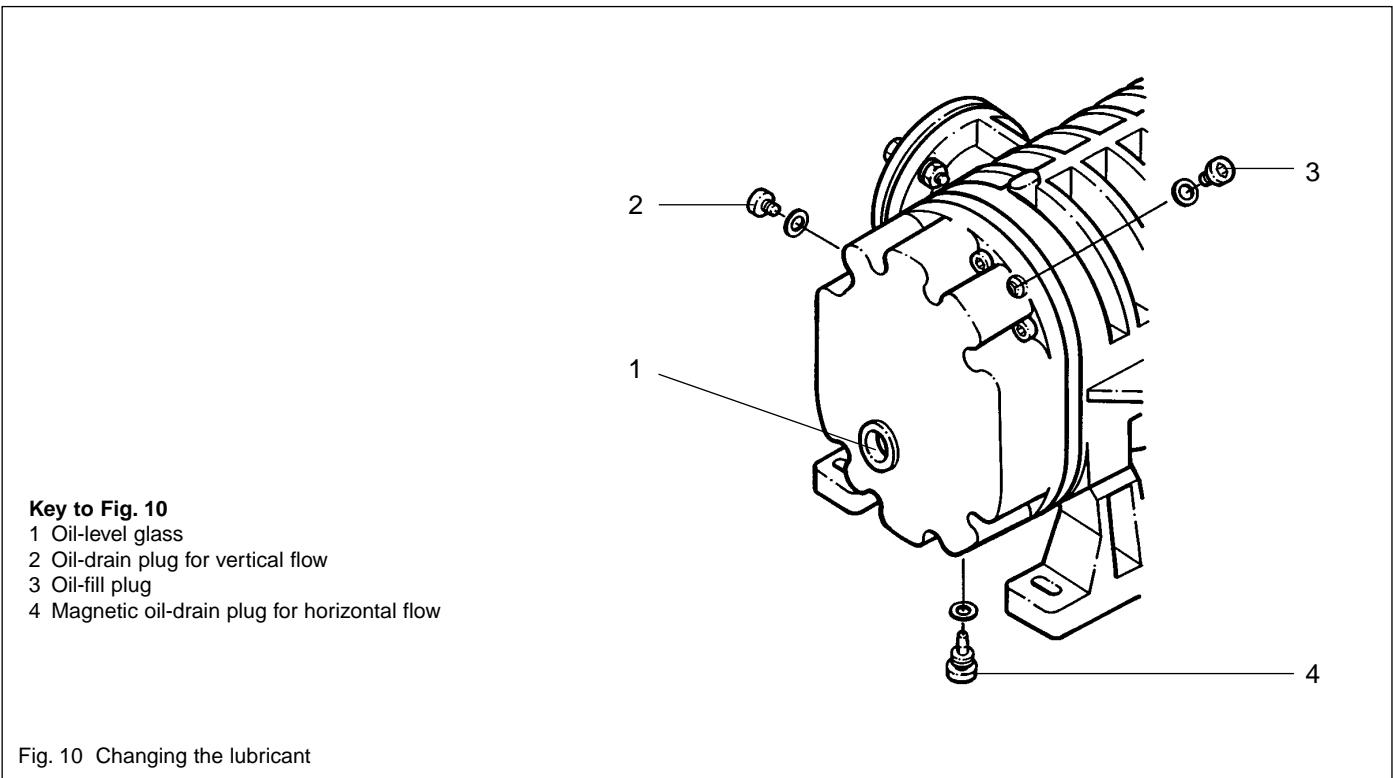

## 5 Maintenance

### 5.1 Safety Information

The safety information given in the following applies to all maintenance work.

**Warning**  Disconnect the electrical power before disassembling the pump. Make absolutely sure that the pump cannot be accidentally started.

If the pump has been pumping harmful substances, determine the nature of hazard and introduce suitable safety measures. Observe all safety regulations !

If you send a pump to LEYBOLD for repair please indicate any harmful substances existing in or around the pump. For this use the „Declaration of Contamination“ form which has been prepared by us and which we will provide upon request.

Any pump received by us without, or an incompletely filled in declaration will delay the repair.

When shipping contaminated pumps which require approval by the authorities, you must observe the applicable packaging and shipping regulations.

**Caution** All maintenance and cleaning work described in this section must be carried out only by suitably trained personnel.

When disposing of used lubricants please observe the relevant environmental regulations.

Improper maintenance or repairs may affect the service life and performance of the pump, and cause problems when filing warranty claims.

Advanced repair work not described here should be left to the LEYBOLD service.

We would like to point out that LEYBOLD offers training courses on the maintenance, repair, and troubleshooting of RUVAC pumps. Further details are available on request.

### 5.2 Exchanging the Lubricant

**Warning** Observe all safety information provided in Section 5.1.



Very little lubricant is consumed by wear in the bearings and the gear under clean operating conditions. We recommend changing the oil or PFPE after the first 500 hours of operation to remove any wearing residue.

Then, under normal operating conditions, change the oil after every 3,000 hours of operation.

Change the oil more frequently when pumping corrosive vapours or large amounts of dust or when cycling frequently from atmospheric to working pressure.

Under such operating conditions it is recommended to regularly check the neutralisation value (to DIN 51 558) based on a sample of oil. If the neutralisation value exceeds 2, an oil exchange will be required.

**Warning** Before removing the oil-drain or oil-fill plug always switch off the pump first and vent to atmospheric pressure.



When the pump has become warm during operation the casing and the oil temperature may exceed 80 °C.



Leave the pump to cool down. Always wear protective gloves also to protect yourself against aggressive residues in the oil.



To simplify the process and also for safety reasons we recommend the use of our oil-drain facility (see Section 1.4).

Unscrew the oil-drain plugs (10/2) or (10/4) and the oil-fill plug (10/3) and drain the oil.

Clean the sealing surface and firmly reinstall the oil-drain plug (10/2) or (10/4) using a gasket which is in perfect condition. Wipe off any oil residues from the casing.

Fill in new oil.

For oil quantities and ordering data see Sections 1.3 and 1.4.

Make sure to use the right kind of oil. PFPE pumps are marked with a red label.

Only use Leybold oil.

**Caution** PFPE and mineral oils do not mix.

Please consult us if you intend to run the pump with other oils or special lubricants.

At vertical flow the correct oil level is in the center of the oil-level glass when the pump is not running.

At horizontal flow the correct oil level must be 6 mm above the center of the oil-level glass (10/1).

**Caution** If the oil level is too low, the bearings and gearwheels are not lubricated adequately; if it is too high, oil may enter the pumping chamber.

Clean the oil-fill port and reinstall the plug (10/3) using a gasket which is in perfect condition. Wipe off any oil residues from the casing.

**Caution** The oil-fill port must be sealed air-tight. In the presence of a vacuum, the entry of air may cause oil-containing gas to enter the pumping chamber via the impeller seals.

When using PFPE as intended, PFPE is not subject to ageing. It must only be changed if it is contaminated by the process gas. It can only be determined for each individual case when the PFPE is so contaminated that it must be changed. To be sure, we recommend changing the PFPE once a year.

Please also take note of the Operating Instructions „PFPE for Vacuum Pumps“ included with the pump.

For recycling contaminated PFPE we ask you to consult us. As PFPE we recommend our NC 1/14 or the HE-1600.

## 5.3 Cleaning the Fan Cowl and the Cooling Fins

**Warning** Observe all safety information provided in Section 5.1.



The slits in the fan cowl as well as the fins on the motor and on the pump may be contaminated depending on humidity conditions and the degree of contamination in the ambient air.

In order to ensure a sufficient air flow for the motor and the pump's casing, the grid of the fan cowl must be cleaned with a clean brush when contaminated.

Any coarse dirt must be removed from the fins on the motor and the pump.

## 5.4 Cleaning the Dirt Trap

**Warning** Observe all safety information provided in Section 5.1.



A wire-mesh sieve is located in the intake port to collect foreign objects. It should be kept clean in order to avoid a reduction of the pumping speed.

To do so, take off the intake line. Remove the dirt trap from the intake flange and rinse it using a suitable solvent. Then thoroughly dry it with compressed air. If the dirt trap is damaged, replace it.

## 5.5 Cleaning the Pumping Chamber

**Warning** Observe all safety information provided in Section 5.1.



Under dirty operating conditions, contaminants may be deposited in the pumping chamber or on the impellers. After removing the two connecting lines, the contaminants can be blown out with dry compressed air or flushed out with a suitable solvent.

Contaminants that cannot be blown or flushed out, can be removed completely from the pumping chamber with a wire brush, metallic sponge or scraper.

Then change the lubricant.

**Warning** During cleaning, the blower must be turned only by hand.



**Caution** The loosened deposits must not remain in the pump. After cleaning, check the pump by slowly turning the impellers by hand. They should move freely and without any resistance.

Generally, the Roots pump does not need to be disassembled. If necessary, this should only be done by our after-sales service.

## 5.6 Cleaning the Valve of the Pressure Balance Line

Observe all safety information provided in Section 5.1.

**Warning**



Remove the screws and take off the cover (11/1) with O-ring (11/2).

Take out the spring (11/4).

Remove the valve disk (11/6) with O-rings (11/5) and (11/7).

If the bushing (11/3) is damaged, pull it out of the valve disk and replace it.

Clean all parts or replace them if necessary. Reassemble in the reverse sequence. When doing so, check the O-rings for leak-tightness and replace if found faulty. Finally a leak test should be run.

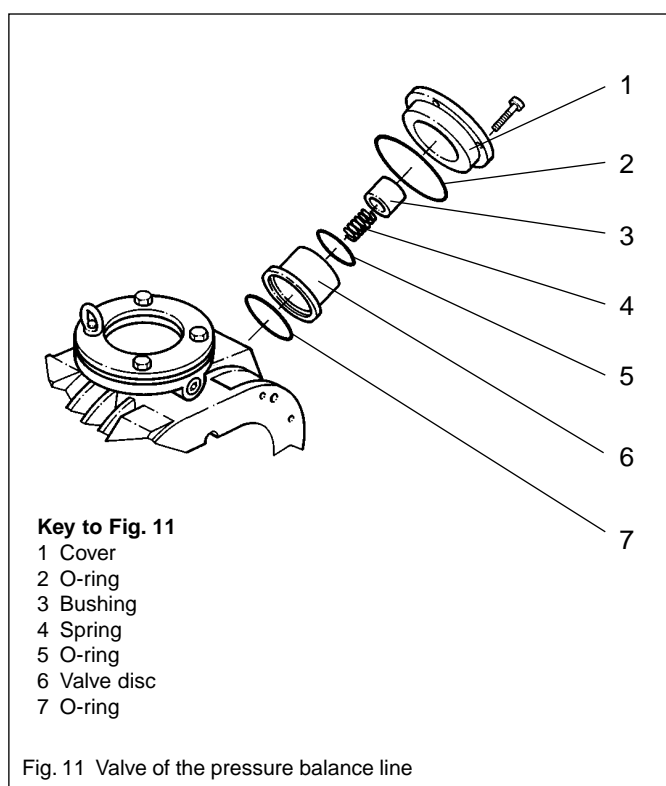

## 5.7 Leybold Service

If a pump is returned to LEYBOLD, indicate whether the pump free of substances damaging to health or whether it is contaminated.

If it is contaminated also indicate the nature of the hazard. For this you must use a form which has been prepared by us which we will provide upon request.

A copy of this form is reproduced at the end of these Operating Instructions: „Declaration of Contamination of Vacuum Instruments and Components“.

Please attach this form to the pump or enclose it with the pump.

This „Declaration of Contamination“ is required to meet German Law and to protect our personnel.

LEYBOLD must return any pumps without a „Declaration of Contamination“ to the sender's address.

**Warning** The pump must be packed in such a way, that it will not be damaged during shipping and so that any contaminants are not released from the package.



# 6 Troubleshooting

Fault	Possible cause	Remedy	Repair*
Pump does not start.	Motor is connected incorrectly. Thermal switch or motor stator is malfunctioning. Pressure switch is malfunctioning. Lubricant is too viscous.  Motor rotor is malfunctioning. Pump has seized up: damaged impellers, bearings or gearwheels.	Connect the motor correctly. Leybold service. Replace the pressure switch. Change the lubricant or warm the lubricant and the pump. Leybold Service Leybold Service	3.3 - 3.3 5.2 - -
Pump gets too hot.	Ambient temperature is too high or cooling air supply is restricted. Pump is working in the wrong pressure range. Pressure differential is too great. Gas temperature is too high. Clearance between casing and impellers is too small due to: - contamination - distortion of pump. Excessive frictional resistance due to contaminated bearings and/or lubricant. Lubricant level is too high. Lubricant level is too low. Wrong lubricant has been used. Bearings are malfunctioning. Fan incorrectly or not connected Fan faulty Valve of pressure balance line does not open.	Install the pump at a suitable site or ensure enough cooling air. Check pressure values of vacuum system. Check pressure values of vacuum system. Check the vacuum system.  Clean the pumping chamber. Ensure that the feet and connecting lines aren't placing a strain on the pump.  Drain some lubricant to reach the correct level. Add lubricant to reach the correct level. Drain lubricant and fill in correct lubricant. Leybold service Connect the fan correctly Leybold service Clean or repair the valve.	3.1/5.3 - - -  5.5 3.1/3.4  5.2 5.2 5.2 - 3.3 - 5.6
Power consumption of the motor is too high.	See fault „Pump gets too hot“. Wrong mains voltage supply for the motor. Motor stator is malfunctioning. Motor rotor is malfunctioning.	See fault „Pump gets too hot“. Connect the motor to the correct voltage supply. Leybold service Leybold service	- 1.3/3.3 - -
Pump is too noise.	Clearance between casing and impellers is too small due to : - contamination - distortion of the pump. Bearing or gearing is damaged. Impellers strike the casing. Motor rotor runs out of true. Centrifugal disc lubricator strikes gear lid or oil tube. Oil pump obstructed or malfunctioning.	Clean the pumping chamber. Ensure that the feet and connecting lines aren't placing a strain on the pump. Leybold service, switch off the pump immediately. Leybold service, switch off the pump immediately. Leybold service, switch off the pump immediately. Leybold service Leybold service, switch off the pump immediately.	5.5 3.1/3.4 - - - - -
Pump loses lubricant.	Lubricant leak is visible: Oil-drain plug is not tight.  Oil-level glass is not tight. Gearbox is not tight. Oil puddle under the motor, leaky can No lubricant leak is visible: See fault „Lubricant in the pumping chamber“.	Drain lubricant, firmly screw in the oil-drain plug with a new gasket, fill in the correct quantity. Leybold service Replace the O-ring of the gearbox cover. Leybold service, switch off the pump immediately.  See fault „Lubricant in the pumping chamber“.	5.2 - - - -
Oil turns dark.	Oil has broken down. Pump gets too hot.	Change the oil. See fault „Pump gets too hot“; after solving the problem, change the oil.	5.2 -
Lubricant in the pumping chamber.	Lubricant level is too high. Lubricant leaks out of the system. Pump is not installed on a flat horizontal surface. Pump has an external leak.  Pump has an internal leak. Impeller rings are malfunctioning.	Drain lubricant to reach the correct oil level. Check system. Install pump correctly. Check proper fit of oil-fill and oil-drain plugs, replace gaskets if necessary. Replace O-ring of the gearbox cover. Leybold service Leybold service	5.2 - 3.1 5.2 - - -
Pumping speed of the pump is too low.	Dirt trap in the intake flange is clogged. Motor is connected incorrectly. Motor stator is malfunctioning. Motor rotor is malfunctioning. Pump or pump system has a leak. Clearance of impellers is too large. Bearing is malfunctioning. Valve of the pressure balance line does not close.	Clean the dirt trap. Connect the motor correctly. Leybold service Leybold service Find and seal the leak. Leybold service Leybold service Clean or repair the valve.	5.4 3.3 - - - - - 5.6

\* for repair information, refer to the stated section in the Operating Instructions





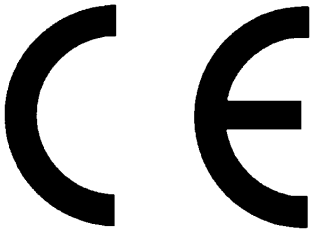

## EEC Declaration of Conformity

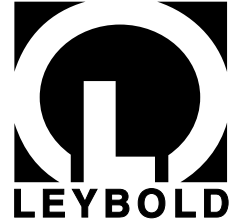

We - LEYBOLD Vacuum GmbH - herewith declare that the products defined below meet the basic requirements regarding safety and health of the relevant EEC directives by design, type and the versions which are brought in to circulation by us.

In case of any products changes made without our approval, this declaration will be void.

Designation of the products: Wälzkolbenpumpe

Types: RUVAC WS 151 - 2001  
RUVAC WSU 151 - 2001

Catalogue numbers:

117 12; 117 13; 117 17; 117 22; 117 23; 117 27;  
117 28; 117 32; 117 33; 117 37; 117 38; 117 42;  
117 43; 117 47; 117 52; 117 53; 117 57;  
917 12; 917 13; 917 17; 917 18;  
917 19; 917 22; 917 23; 917 27;  
917 28; 917 29; 917 32; 917 33;  
917 37; 917 38; 917 42; 917 43;  
917 47; 917 48; 917 52; 917 53

### **The products conform to the following directives:**

- EEC Directive on Machinery (89/392/EWG) and subsequent. 91/368/EWG
- EEC Directive on Low Voltages (73/23/EWG)
- EEC Directive on Elektromagnetic Compatibility (89/336/EWG)

### **Applied harmonised standards:**

- EN 292 Part 1 and Part 2      Nov. 1991
- pr. EN 1012 Part 2            1993
- EN 60 204                        1993

### **Applied national standards and technical specifications:**

- DIN 31 001                        April 1983
- DIN ISO 1940                    Dec. 1993

Cologne, December 8, 1995

  
\_\_\_\_\_  
Plingen, Business Area Manager  
Forevacuum pumps

Cologne, December 8, 1995

  
\_\_\_\_\_  
Frings, Design Department Manager  
Forevacuum pumps

---

---

---

**LEYBOLD VAKUUM GmbH**

Bonner Straße 498 (Bayenthal)  
D-50968 Köln

Telefon: (0221) 347-0

Telefax: (0221) 347-1250

1.80.6.637.53      OF/RSP      11.96

Printed in Germany on chlorine-free bleached paper