

NESLAB HX 150 Recirculating Chiller

Thermo Manual P/N U00058
Rev. 09/09/97

No part of this publication may be reproduced or reprinted except for personal use without the prior permission of Thermo Electron.

Refrigeration Service

Thermo
ELECTRON CORPORATION

Contents

General Information

After Sale Support	2
CAUTION	3
Theory of operation	4
Cool mode	4
Heat/idle mode	5

Troubleshooting

Troubleshooting Chart: Runaway cold	6
Troubleshooting Chart: Runaway hot	7
Troubleshooting Chart: Weak cooling	8
Troubleshooting Chart: Refrigeration pressures	10

Replacement

Compressor	11
Fan Motor	13
Filter/dryer	14
Solenoid valve	15
Tank coil assembly (TCA)	17
Water regulating valve	21
Capillary tube	23
Refrigeration components (general)	25

Procedures

Speed check	27
Suction Discharge pressure and speed check	28
Condenser maintenance (air cooled & water cooled)	29
Flushing (closed facility system)	29
Flushing (tap water system)	30
Flushing (unit off)	31
Commercial flushing chemicals	32
Hot gas valve (Automatic Discharge Relief (ADR))	33
Schrader valves	37
Leak test and repair of leak	38
Solenoid coil test	39
Solenoid valve rebuild	40
Tank Coil Assembly (TCA) failure and repair	42

Water regulating valve setting	43
--------------------------------------	----

Reference

Refrigeration Specifications	44
R22 pressure-temperature chart	45
Heat load calculation	46
Condenser requirements: Air-cooled units	47
Condenser requirements: Water-cooled units	48
15-pin accessory connector (optional) pinout	49
Part numbers	50



CAUTION

This section is intended for use by qualified refrigeration technicians only. Servicing refrigeration systems is hazardous and must be performed only by qualified persons.

Refrigeration systems contain various hazards, including (but not limited to) the following:

1. Refrigeration systems contain refrigerant gases at very high pressures, even when not running.
2. Sudden release of refrigerant gases will result in rapid expansion and severe frostbite hazard. Refrigerant gases will cause severe injury to unprotected flesh.
3. Refrigerant gases are not flammable and are chemically inert. However, they are heavier than air and will displace oxygen. They can cause suffocation if released in a confined area.
4. Refrigerant gases used in this product are classified as Ozone Depleting Chemicals by the US Environmental Protection Agency. While they pose no hazard sealed inside the refrigeration system, intentional release into the atmosphere is outlawed under the 1990 Clean Air Act.
5. Compressor start and run capacitors store hazardous levels of electricity, even when the unit is not running or plugged in.
6. Refrigeration system components operate at high temperatures and present a severe burn hazard.

THEORY OF OPERATION

The chiller operates in two modes: COOL or HEAT/IDLE. The controller compares setpoint to actual temperature and decides which mode is required. This is a thermostatic (not proportional) control system. The compressor, pump, and fan motor all run continuously, regardless of mode.

The thermal transfer of the HEAT/IDLE mode is not as efficient as the COOL mode. This results in units running at little or no load to spend most of their time in the HEAT/IDLE mode with brief periodic COOL periods. A duty cycle of 20% COOL / 80% HEAT/IDLE may be typical for units running under no load. This duty cycle will reverse as increasing load is applied, reaching 100% COOL / 0% HEAT/IDLE at full load.

This system results in tighter temperature control than continually cycling the compressor on and off, as is typical in a household refrigerator.

The default mode is HEAT/IDLE. A failure of the temperature sensor or controller will generally result in the HEAT/IDLE mode. This prevents a possible freezing of the cooling fluid and resulting damage from fluid expansion.

COOL MODE

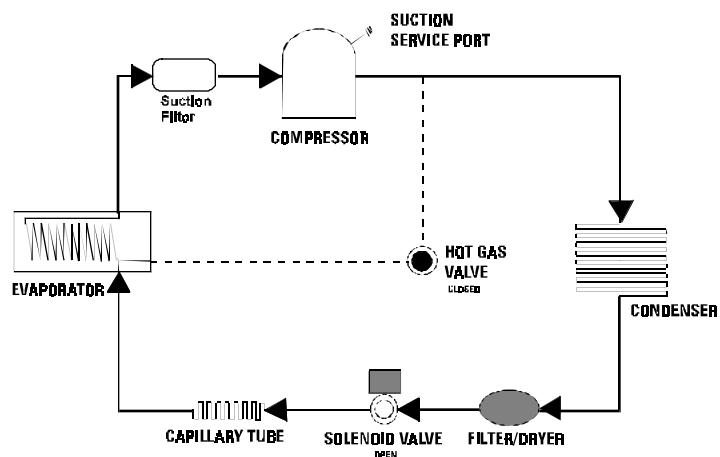

If the setpoint is below the actual temperature, the controller is in COOL mode. The controller triac output provides a closure to supply line voltage to the solenoid coil. The solenoid valve, which is normally-closed, is then pulled open by the coil and a standard refrigeration cooling loop exists.

Refrigerant, as a gas, is pressurized in the compressor. It then enters the condenser and changes to a liquid due to the cooling provided by the fan and condenser fins. Heat is given up to the air at this point. The liquid refrigerant exits the condenser and passes through a filter/dryer which traps contaminants and absorbs any water moisture in its desiccant element. The refrigerant then passes through the open solenoid valve and enters the capillary tube. The restriction of the tube meters the flow. The capillary tube ends at the evaporator.

The evaporator is a coil located inside the fluid tank. As the liquid refrigerant encounters the increased volume of the evaporator, it expands tremendously, changing from a liquid to a gas, and absorbing heat from the fluid (cooling it) in the process. The refrigerant, now a gas, exits the evaporator and passes through the suction filter. The refrigerant then enters the compressor at low pressure and is re-compressed.

HEAT/IDLE MODE

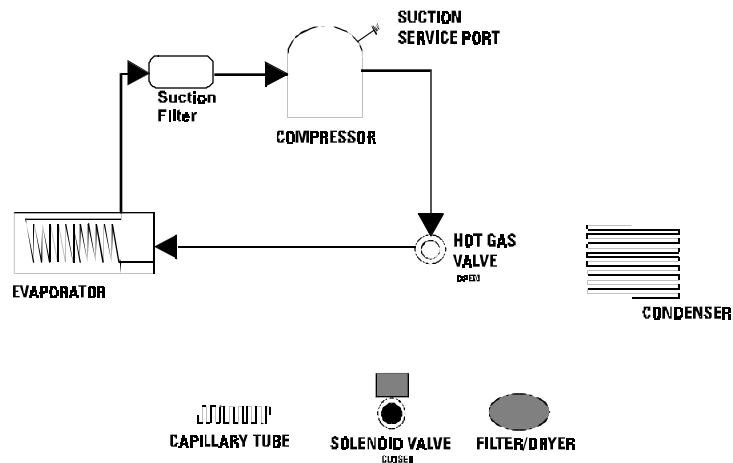

If the setpoint is above the actual temperature, the controller is in HEAT/IDLE mode. The triac output opens, turning the solenoid coil off. The solenoid valve then drops closed. This closed valve stops the flow of refrigerant. During the heat/idle mode when the liquid line solenoid valve is closed, the pressure drops in the suction line back to the compressor. When the pressure drops to a predetermined value, the hot gas bypass valve will open and allow hot gas to flow to the evaporator as stated. The hot gas valve opens on a decrease in pressure on its discharge port. The discharge port is connected to the evaporator side of the system. The refrigerant gas is now routed directly to the evaporator. The gas is not allowed to condense, as it has bypassed the condenser completely. The hot gas passing through the evaporator coil adds some heat to the fluid, then returns directly through the suction filter to the compressor. This unloads the compressor, resulting in lower discharge pressure, higher suction pressure, and less power consumption. Observing the suction pressure in this mode will indicate the setting of the Hot Gas (ADR) valve.

Troubleshooting Chart: Runaway cold

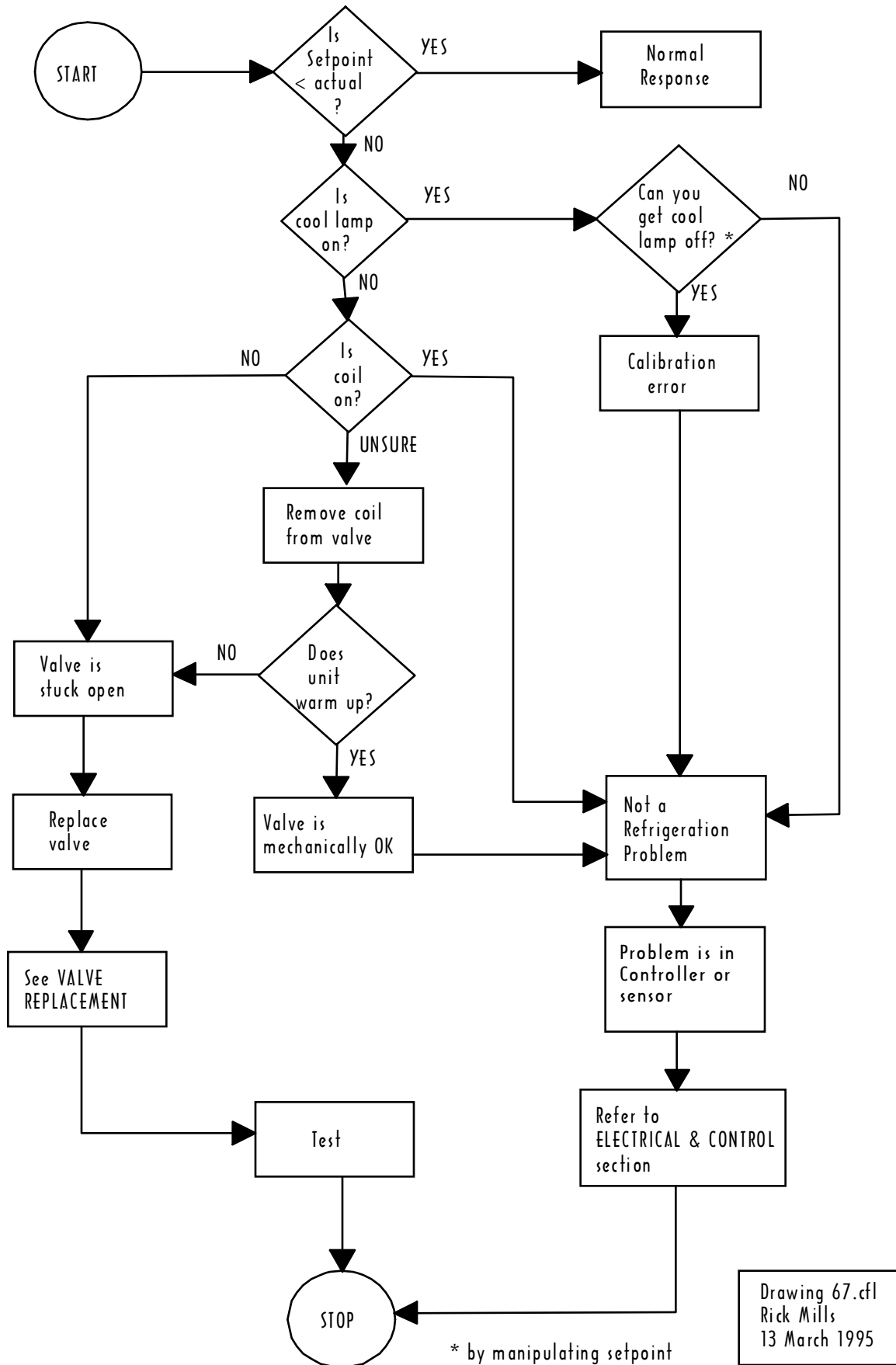

Troubleshooting Chart: Runaway hot

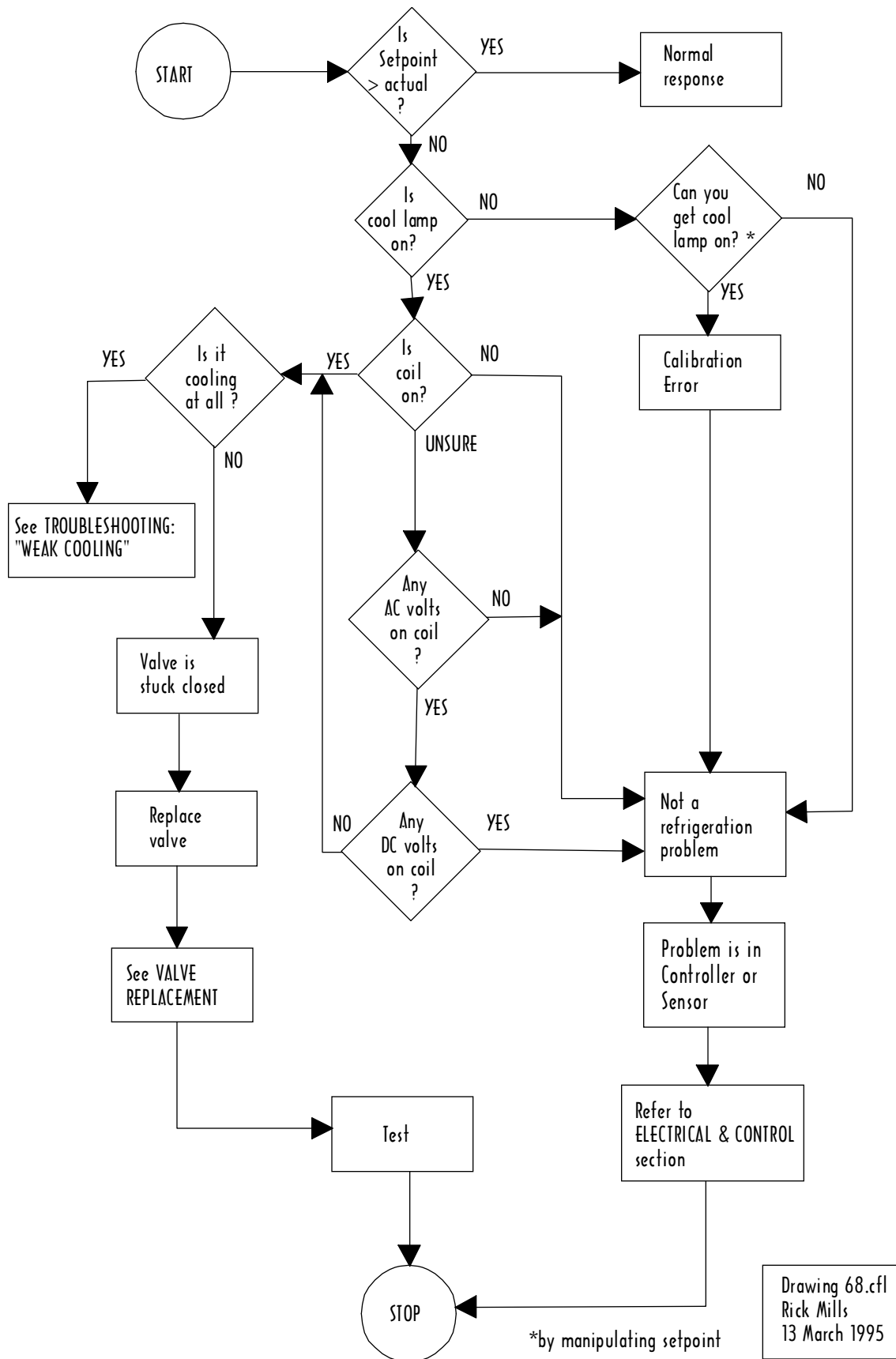

Drawing 68.cfl
Rick Mills
13 March 1995

Troubleshooting Chart: Weak cooling

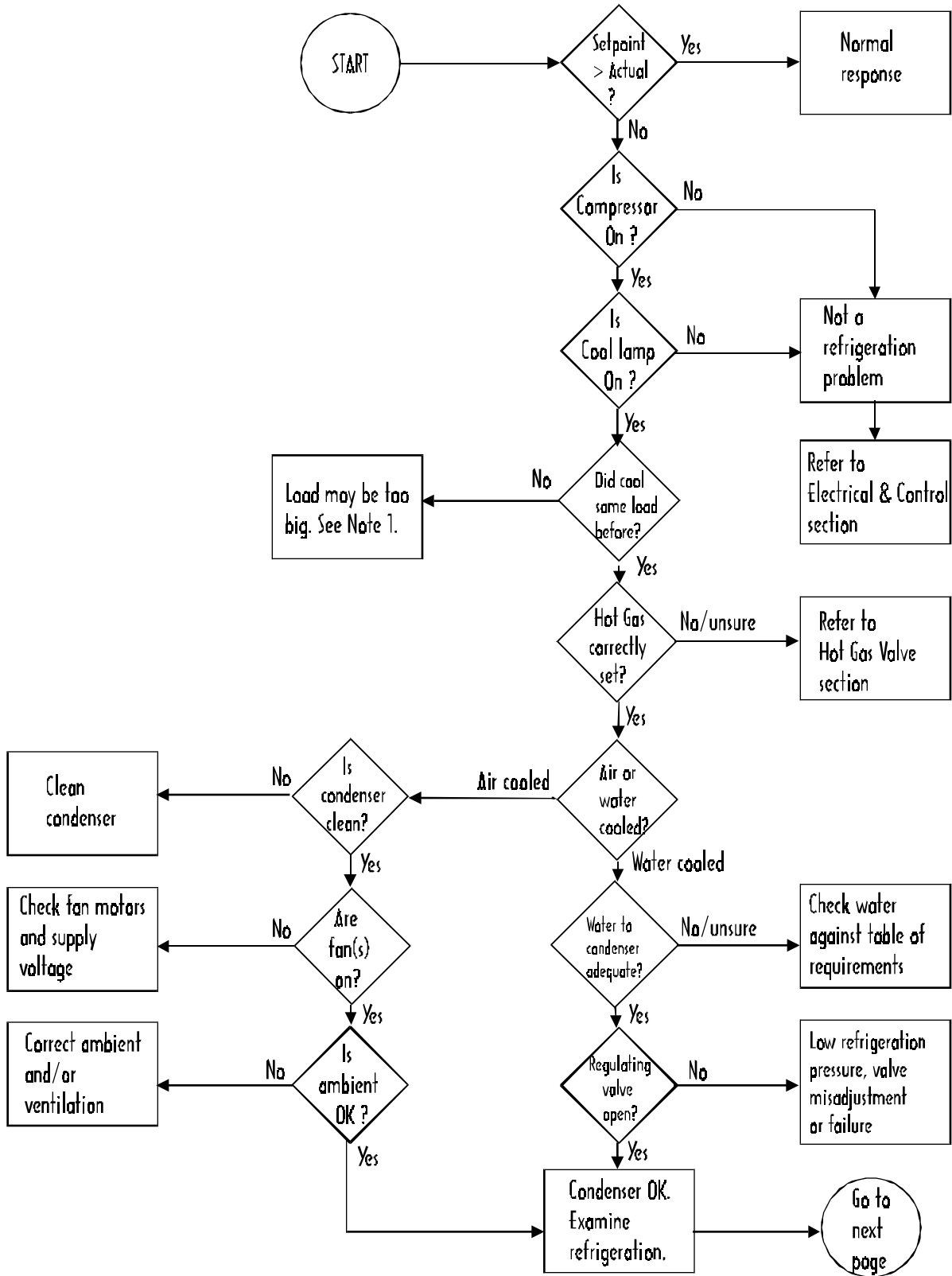

Note 1: Compare load size to HX catalog spec. If load size unknown, determine using heat load formula.

Drawing 5193a.cdr
Rick Mills
14 Mar 1995

Troubleshooting Chart: Weak cooling continued

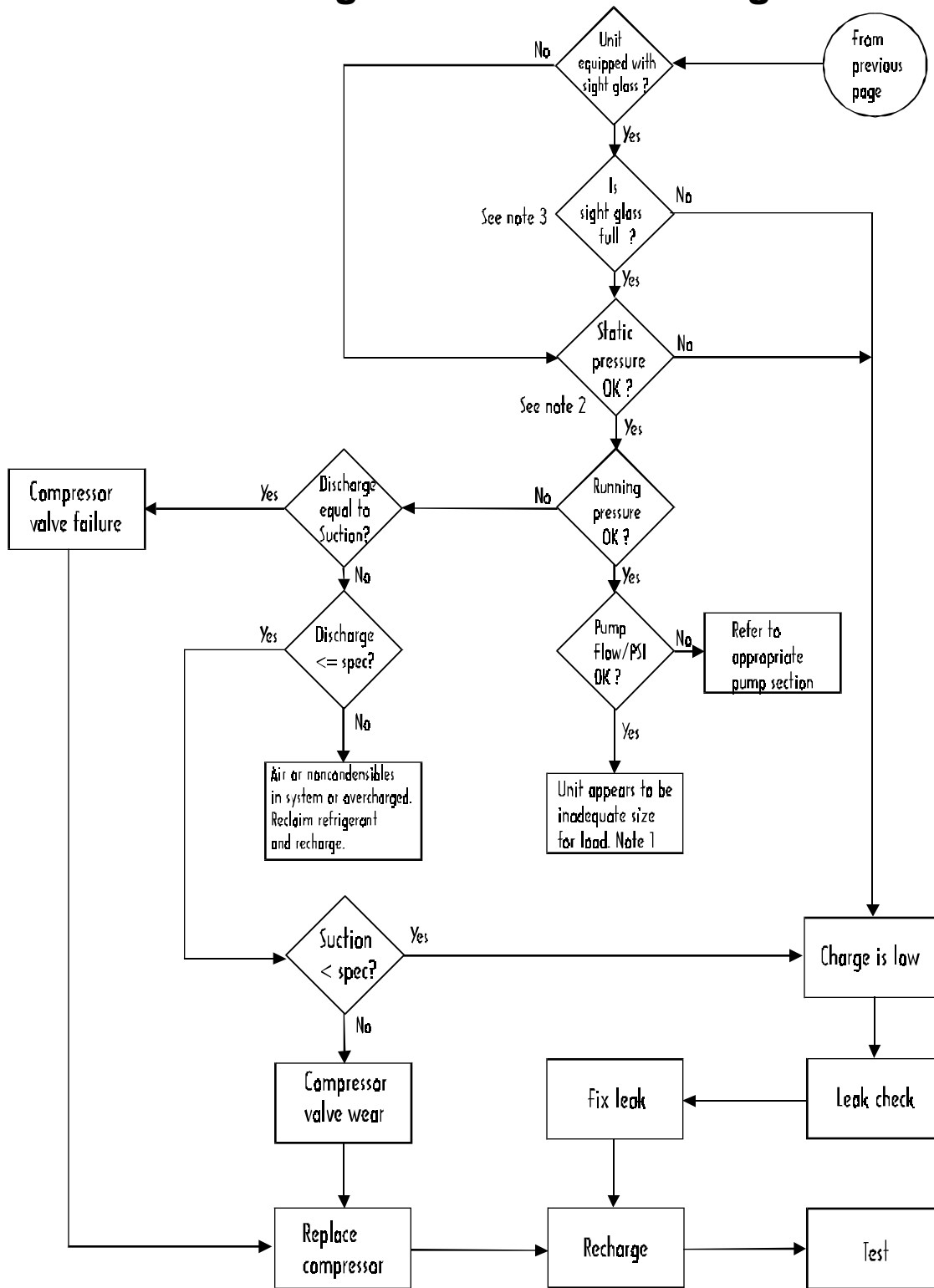

Note 1: Compare load size to HX catalog spec. If load size unknown, determine using heat load formula.

Note 2: Refer to Temperature/pressure chart.

Note 3: Sight glass should fill with liquid upon entering cool cycle, and empty shortly after entering heat cycle.

Drawing 5193b.cdr
Rick Mills
14 Mar 1995

Troubleshooting Chart: Refrigeration pressures

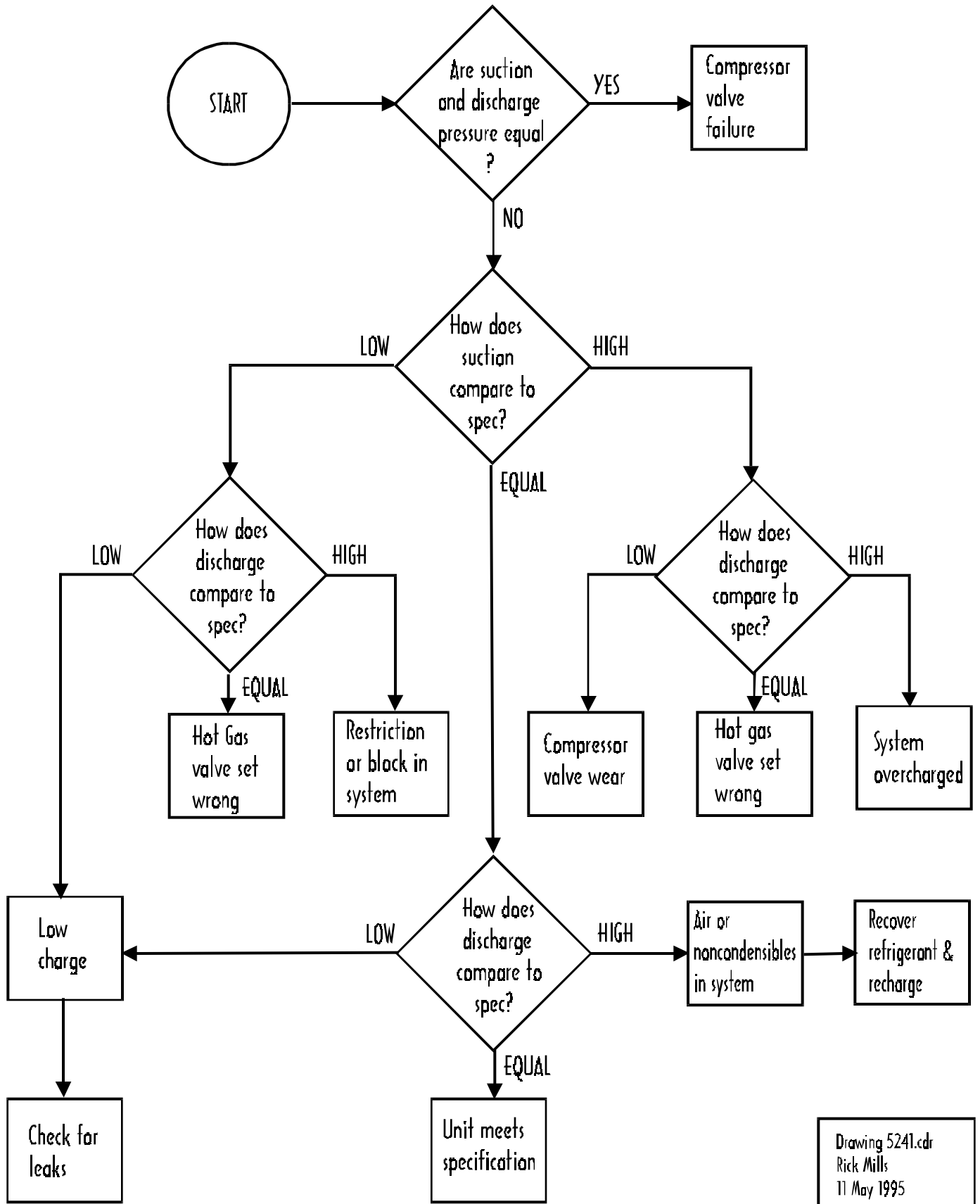

Drawing 5241.cdr
Rick Mills
11 May 1995

Compressor replacement

1. Remove all access panels.
2. Confirm that the problem is not external to the compressor (electrical) before proceeding. If the compressor does not start/run, check the following:
 - A. Is proper voltage present at the compressor terminals?
 - B. Are all starting devices (capacitors, potential relays) good?



Disconnect the unit from line voltage

- C. Are the motor windings known to be good or bad? If in doubt, Ohmmeter readings of the windings may be compared to the replacement compressor.
3. Recover the system refrigerant.
4. Disconnect wires, starting devices, etc. from compressor.
5. Remove valve cores from both Schrader valves.
6. Remove the coil from the solenoid valve and move it out of the torch area. Wrap a damp rag around the solenoid valve body.
7. Unsolder and remove compressor and dryer.

NOTE: If a compressor burnout is suspected, invert old compressor and drain out a small sample of oil. Test the oil for acidity, following the manufacturer's recommendations on the acid test kit. If the oil is acidic, the refrigeration system will need flushing to remove the acidic oil. Replace with new oil.

8. Unpack new compressor. Remove plugs from the ports.



Compressors are typically shipped pressurized with a dry nitrogen charge. Safety glasses are especially necessary when removing plugs. Orient compressor so the plug will exit the port pointing away from you and others.

NOTE: Replacement Copeland compressors already contain an adequate oil charge. It is not necessary to add any oil to the new compressor.

9. Remove the suction service port stem from the old compressor, and insert it into the new compressor.
10. Apply nitrogen purge gas to the stem.
11. Braze in place using BAg 28 (silver solder) compound.
12. Position the new compressor in place.
13. Position the new dryer in place. Ensure the flow direction arrow points toward the solenoid valve.
14. Wrap a damp rag around the dryer.
15. Apply nitrogen purge gas to the suction service port.
16. Braze the suction and discharge lines to the compressor, using BAg 28.
17. Braze the dryer in place, using BAg 28.
18. Insert new valve cores in the Schrader valves.
19. Pressurize system and leak check.
20. Evacuate system.
21. Charge system to specification.
22. Test system.

Fan Motor Replacement



1. **Disconnect unit from its electrical power supply.**
2. Note the location and orientation of the electrical wiring for installation.
3. Disconnect the electrical wiring.
4. Unbolt the fan from the base of the condensing unit.
5. Pull the fan assembly (motor, blade, and bracket) out of the unit.
6. Transfer the blade, conduit, and/or bracket to the new motor.
7. Reassemble in reverse order.

FILTER/DRYER REPLACEMENT

NOTE: The filter/dryer contains a desiccant which will absorb moisture from the atmosphere. The filter/dryer should be replaced whenever the refrigeration system has been opened and allowed to go to atmospheric pressure. Unsealing and installing the new filter/dryer should be left until the last possible minute to minimize contamination of its desiccant.



Disconnect the unit from line voltage

1. Recover the system refrigerant.
2. Remove all Schrader valve cores.
3. Remove solenoid valve internal components (See “Solenoid valve replacement procedure” for drawing) Wrap a damp rag around the solenoid valve body.
4. Apply purge gas to the system.
5. Desolder and remove old filter/dryer.
6. Place new filter/dryer in position, with direction-of-flow arrow pointing towards the liquid line solenoid valve.
7. Wrap the filter/dryer body in a damp rag.
8. Introduce nitrogen purge gas into the discharge service port.
9. Braze connections using BAg 28. Orient torch flame away from the filter/dryer body. Any bubbling of the paint on the filter/dryer indicates excessive temperature is being approached - stop and allow to cool if this occurs.
10. Remove the damp rags and the nitrogen supply.
11. Insert new Schrader valve cores.
12. Assemble the solenoid valve (Do Not over tighten - Use two wrenches).
11. Pressurize and leak check.
12. Evacuate system.
13. Charge system.
14. Test.
15. Install any access panels removed.

Solenoid valve replacement:



Disconnect the unit from line voltage

1. Recover refrigerant.
2. Remove coil.
3. Remove all valve cores from the Schrader valves.
4. Note the direction of flow so that the new valve can be properly positioned during assembly. Disassemble solenoid valve and remove internal components as shown below.

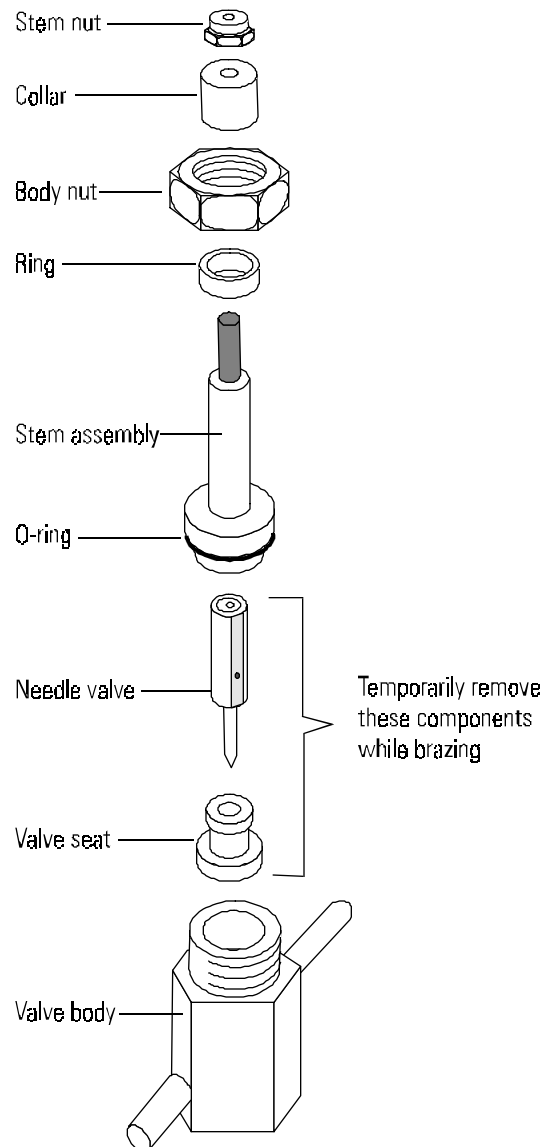

5. Protect all components that could be affected by the soldering flame with damp rags and metal shielding.
6. Apply a nitrogen purge gas to the system.
7. Unsolder the valve and dryer and remove.
8. Place new valve and dryer in position. Check that the flow direction arrows on both devices point towards the capillary tube.
9. Wrap a damp rag around the valve and dryer and protect any other components/wiring with damp rags and metal shields.
10. Apply nitrogen purge gas to the system.
11. Braze in place using BAg 28 compound (silver solder).
12. Remove rags and inspect brazing.
13. Install new valve cores in the Schrader valves.
14. Assemble solenoid valve assembly. (Use two wrenches and do not over tighten.)
15. Pressurize system and leak check. The solenoid valve is closed, so be sure to pressurize both sides.
12. Evacuate the refrigeration system.
13. Install coil.
14. Charge system to specification.
15. Test system.
16. Install any access panels removed.

Tank Coil Assembly (TCA) replacement

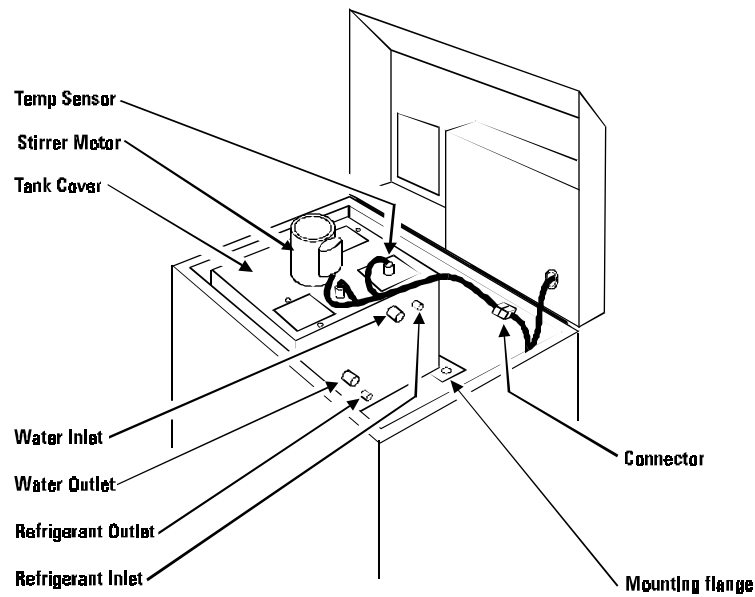

Drawing 5245.cdr
Rick Mills
4 Apr 1995

NOTE: The evaporator coil and the water tank are one unit. They cannot be separated. The following procedure assumes that the pump along with its plumbing has been removed.



Disconnect unit from line voltage.

1. Recover refrigerant, if any remains.
2. Drain fluid from system.
3. Remove valve cores from both Schrader valves.

4. Remove screws from Tank Cover and lift it off the tank with all wires, motors, sensors, etc. intact. Invert it and place it to the side as shown. If more slack is required in the wires, unplug the connector shown.

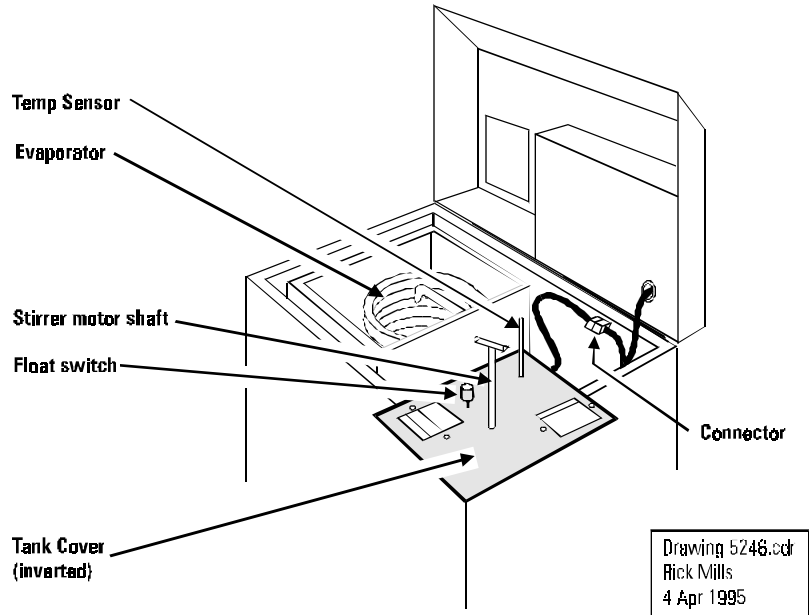

5. Remove the two fluid hoses from the water inlet and outlet stubs.
6. Remove the insulation from the refrigerant inlet and outlet lines.
7. Unsolder the refrigerant inlet and outlet lines.



CAUTION: The refrigerant inlet and outlet lines are stainless steel. They are easily damaged by excessive heat. Never apply the torch flame directly to the stainless. Warm the copper fittings up slowly and evenly until the solder liquefies.

8. Remove the four screws that hold the TCA mounting flange to the mounting rails.

9. Lift the TCA straight up out of the unit.

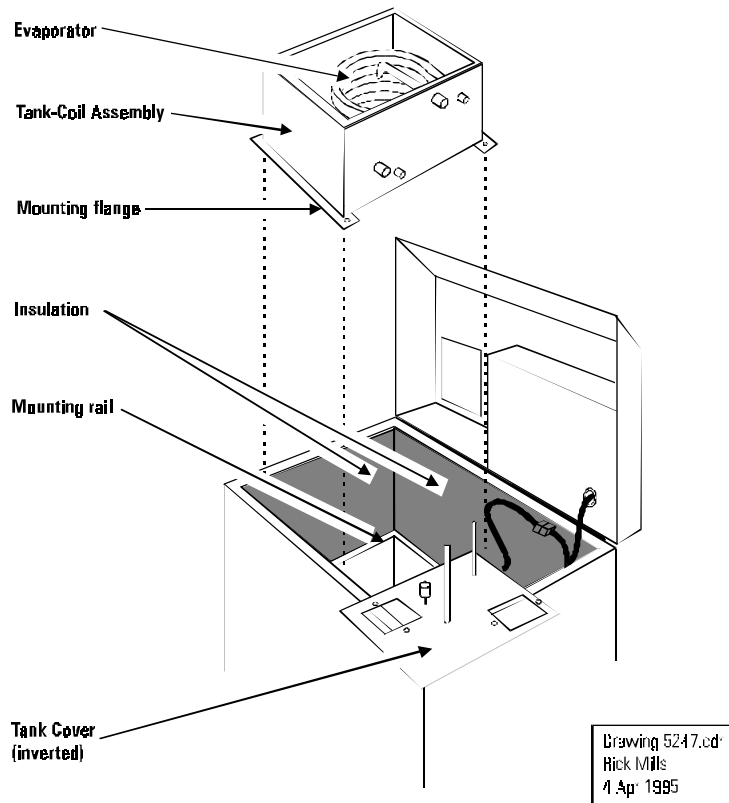

10. Inspect the insulation on the inside of the case walls while the TCA is removed. Replace any that is wet. Install insulation on the new TCA.
11. Transfer the strainer from inside the old TCA to the new TCA, if required.
12. Clean the refrigeration stubs on the new TCA carefully prior to installation. Clean the inside of the mating copper lines prior to installation.
13. Lower the TCA into place and secure the mounting flange to the mounting rails.



CAUTION: The refrigerant inlet and outlet lines are stainless steel. They are easily damaged by excessive heat. Solder the fittings as follows:

- A. Ensure all fittings have been carefully cleaned.
- B. Apply a paste-type flux.

C. Assemble fittings.

D. Apply nitrogen purge gas to the suction service port.

E. Warm the copper fittings slowly and evenly.
Do not rush this procedure. Observe the flux change to a watery clear state.



CAUTION: Never apply the torch flame directly to the stainless.

F. Apply BAg 28 (silver) solder.



CAUTION: The stainless must never be hot enough to turn cherry red. This will cause oxidation and the solder will not wet the oxidized material. If this occurs, stop immediately. Allow fittings to cool. Polish the stainless fittings with emery cloth until all traces of dark oxidation are removed.

14. Disconnect nitrogen purge gas.

15. Install new valve cores in the Shrader valves.

16. Pressurize system and leak check.

17. Evacuate system.

18. Charge system to specification.

19. Test system.

WATER REGULATING VALVE: REPLACEMENT (present on water-cooled units only)



Disconnect unit from its electrical power supply.

1. Recover refrigerant charge.
2. Remove valve cores from both Shrader valves.
3. Apply nitrogen purge gas to the discharge service port.
4. Unbrazed the valve's sensor pickup from the compressor discharge line.
5. Braze the new valve's sensor pickup in place using BCuP3 or BCuP5 brazing compound. Silver-based solder is not recommended for this joint.
6. Remove nitrogen supply.
7. Install new valve cores.
8. Begin evacuation of refrigeration system.
9. While system is being pumped down, Turn the adjusting screw on the old valve fully closed (CCW). Count how many turns are required to close it.

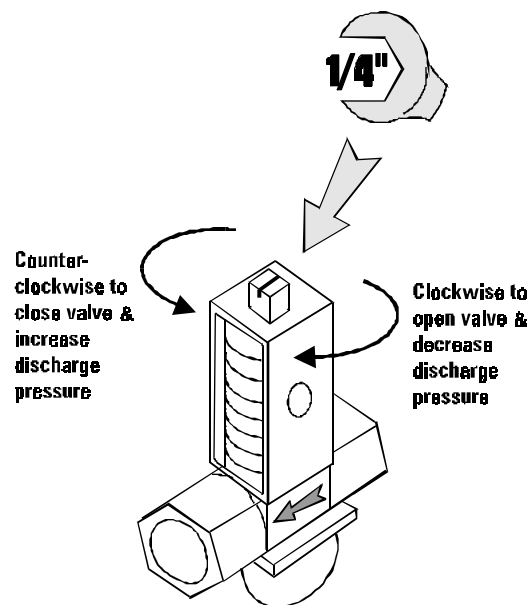

Dim'ing 5274.crv
30 Mar 1995

10. Disassemble the two unions holding the original valve in place.
11. Remove original valve.
12. Transfer fittings to new valve.
13. Mount new valve using the two unions.
14. Turn the adjusting screw on the new valve fully closed.
15. Now back it out the number of turns observed in the previous step. This will approximate the correct setting.
16. Pressurize system and leak check.
17. Evacuate system.
18. Recharge refrigeration system.
19. Test.

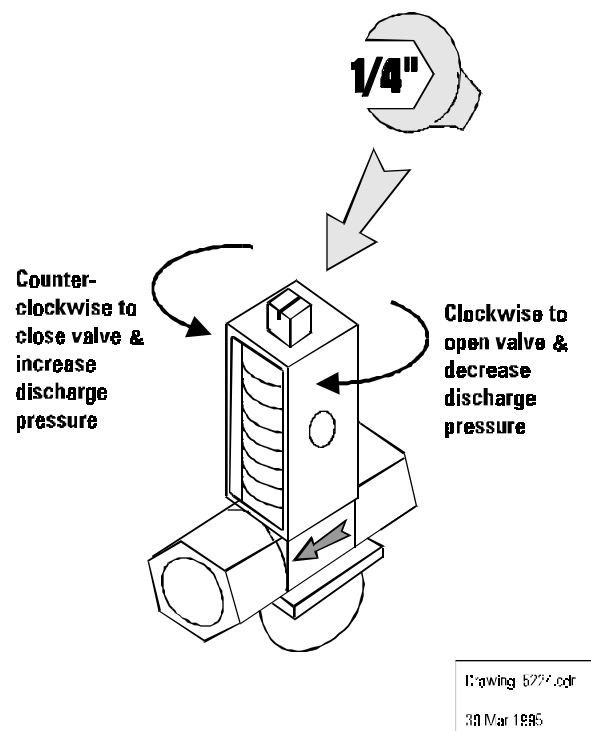

Capillary Tube Replacement

Refer to the appropriate callout drawings to identify the capillary tube location.

1. Recover refrigerant charge.
2. Remove both valve cores.
3. Pull back insulation from ends of cap tube. Secure with a clothespin or similar clamp.
4. Disassemble Solenoid valve (see solenoid replacement procedure for details and illustration). Wrap solenoid valve body with a damp rag.
5. Apply gaseous nitrogen purge.
6. Desolder each end of the capillary tube and remove from fittings.
7. Rough cut new capillary tube to length shown below.

Capillary Tube Dimensions

Unit	I.D.	Rough cut		Finish cut	
	Inches	Inches	CM	Inches	CM
HX100AC	0.075	49	124	48	122
HX100WC	0.075	39	98	38	96
HX150AC	0.085	61	154	60	152
HX150WC	0.085	49	124	48	122

Note: These values only for Copeland R22 systems.

8. Ensure the ends of the new capillary tube are closed. If open, cover using masking tape.
9. Transfer insulation tube from old capillary tube to new capillary tube.
10. Score capillary tube ½" (1 cm) from each end. Snap off at score to produce finish length shown.
11. Place capillary tube in position. Form a loop with any excess length.
12. Pull back insulation from ends of cap tube. Secure with a clothespin or similar clamp.
13. Introduce nitrogen purge gas in the suction service port.

Capillary Tube Replacement (continued)

14. Braze upper end of capillary tube first, using a phosphon-type brazing compound (BCuP3 or BCuP5). This compound has a wide plastic state which will minimize the chance of liquid brazing compound wicking into the joint and blocking the end of the capillary tube. Silver-type solder (BAg28) is not recommended for capillary tube connections.
15. Braze the lower end to the capillary tube to the solenoid valve in a similar manner.
16. Remove the damp rag; nitrogen purge and the clips holding the insulation back.
17. Reassemble solenoid valve.
18. Insert new valve cores.
19. Pressurize and leak check.
20. Evacuate system.
21. Charge system.

Refrigeration Components General Replacement Procedures

Note: Make note of the in/out orientation of all components before disassembly so that they may be correctly oriented during installation. The Filter/Dryer should always be changed along with any other refrigeration component or when the refrigeration system has been exposed to atmospheric moisture.



1. **Disconnect the unit from line voltage**
2. Remove access panels.
3. Recover system refrigerant.
4. Remove the valve cores.
5. Remove solenoid coil/s.
6. Disassemble solenoid valve/s (this procedure is shown in the “Solenoid valve replacement procedure”) and remove the internal components (for purging). Place the nut and stem back on the valve and secure snugly.
7. Protect all components that could be damaged during brazing with damp rags and/or metal shielding.
8. Apply a slow nitrogen gas purge.
9. Unsolder all components being changed and remove.
10. Remove nitrogen purge.

NOTE: All components should be clean and silver soldering flux applied. The Filter/Dryer should be the last component installed to prevent contamination.

11. Place new components into position. Check that the “IN” / “OUT” sides are in proper orientation in the system as notes before removal. If a new solenoid valve is being installed make sure that it is disassembled (see step 6 above).

12. Ensure that all components are protected from heat with damp rags and / or metal shields.
13. Apply a slow nitrogen gas purge.
14. Braze component/s in place using BAg 28 compound silver solder.
15. Remove all rags and metal shielding.
16. Inspect all brazing joints.
17. Assemble solenoid valve/s internal parts (this procedure is shown in the “Solenoid valve replacement procedure”).
18. Install new valve cores.
19. Pressurize the system and check for leaks. Be sure to pressurize both sides of any solenoid valve and the high and low side of the system.
20. Evacuate the refrigeration system.
21. Charge the refrigeration system to specifications.
22. Test the unit for proper operation.
23. Install all access covers.

Speed check

Speed Check is a term used to describe how fast a unit can cool across 20°C when it is running at maximum capacity. The unit of measure is “degrees per minute”. This will provide a number that is easy to obtain and compare.

1. Find the DROP figure from the table. (For example, the HX100 with a PD-1 pump has a drop of 1.4°C.)
2. Divide the drop in half. (Example: 0.7°C)
3. Add this half to 20°C to find the START point. (Example: 20.7°C)
4. Subtract this half from 20°C to find the STOP point. (Example: 19.3°C). Now the entire drop is centered about 20°C.
5. Connect the unit’s inlet and outlet with as short a loop of hose as practical. Insert a thermometer with 0.1°C resolution in the loop.

SPEED CHECK TO PROVE 1.4°C/MINUTE

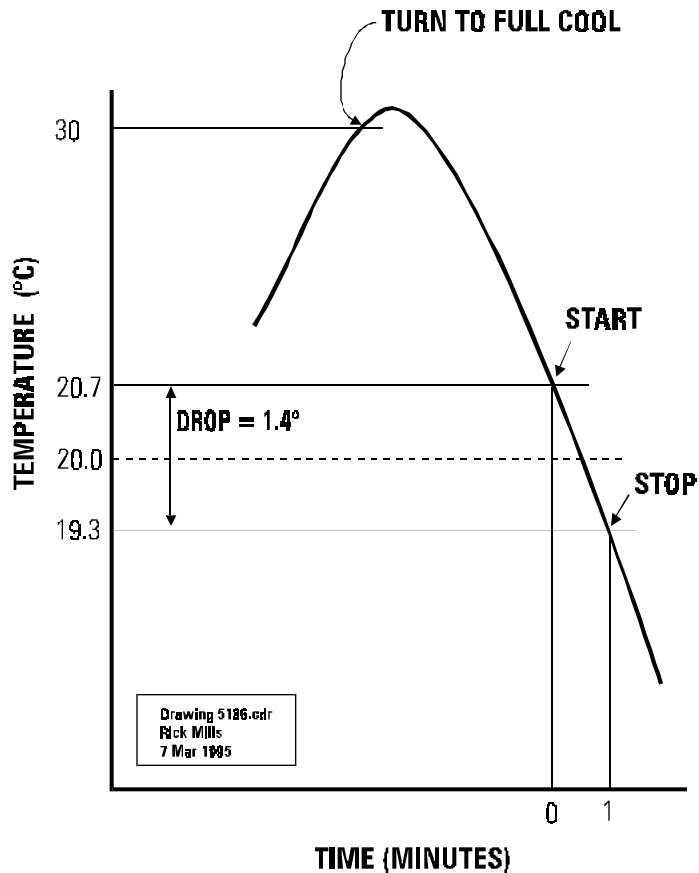

6. Ensure the fluid used is 100% water. Heat the fluid to at least 30°C, then turn unit to full cool.
7. Begin timing as soon as the START temp (20.7°C) is passed.
8. Stop timing when the STOP temp (19.3°C) is passed.
9. Elapsed time must be one minute or less.

Suction Discharge Pressure and Speed Check

Air-Cooled Standard and High Temperature Units (All Pump Types)¹			
Unit	Suction(psi)	Discharge(psi)	Speed Check(°C/Minute)
HX-100	75 - 83	245 - 265	1.3 - 1.6
HX-150	70 - 73	240 - 270	2.0 - 2.5

Water-Cooled Standard and High Temperature Units (All Pump Types)²			
Unit	Suction(psi)	Discharge(psi)	
HX-100	86 - 92	180	Speed check times not established.
HX-150	65	175	

NOTE: For low temperature units please call NESLAB.

Condenser, Air Cooled

The condenser should be cleaned periodically. The grille covering the condenser is removable. The best way to remove dust is to force it out in the opposite direction from which it entered. If compressed air is available, direct the air against the inside of the condenser. If a vacuum cleaner is used, apply the vacuum to the outside of the condenser. Straighten any bent fins using a fin comb.

Condenser, Water cooled

The water cooled condenser generally needs no maintenance. If the cooling water is particularly dirty, deposits may occur and cause flow restrictions. In this event flushing may be required. The procedure used depends on whether a closed facility water cooling system or a tap water system is used. The procedures are described on the following pages.

Flushing using a closed facility system

1. Turn HX off.
2. Close valves on cooling water supply and return lines.
3. Disconnect hoses from cooling water supply and return, and reverse them.

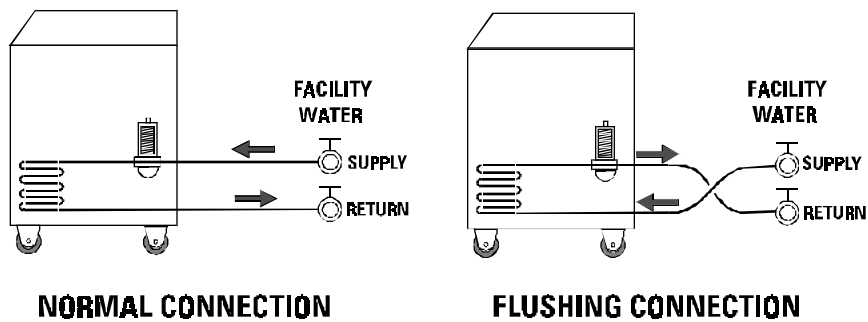

Drawing 57 DEW-27
Truck Mills
23 March 1995

Flushing closed facility system (continued)

4. Open valves on cooling water supply and return lines.
5. Run HX normally for 10-15 minutes. Adjust setpoint so HX cycles between heat and cool. The condenser flow is now reversed. This reverse flow will tend to loosen any deposits. Cooling performance may be less, and the water regulating valve may make some vibration noise.
6. Turn HX off.
7. Close valves on cooling water supply and return lines.
8. Restore hoses to original configuration.
9. Open valves on cooling water supply and return lines.

Flushing using a tap water system

1. Turn HX off.
2. Close valve on cooling water supply line.
3. Disconnect hoses from cooling water supply and drain, and reverse them.

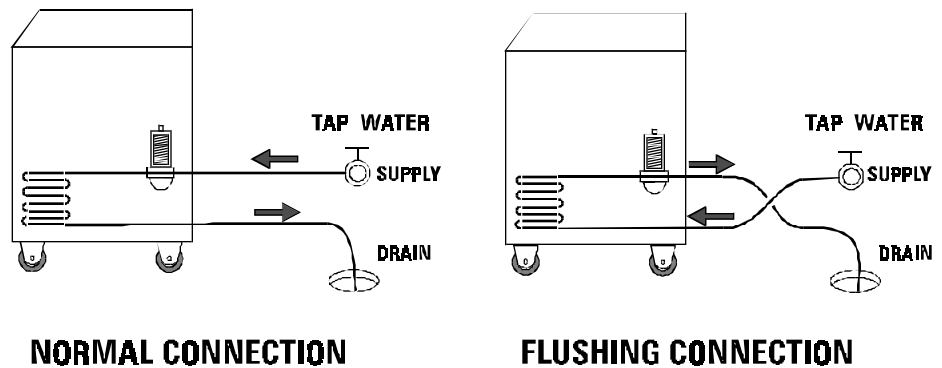

Drawing 3071.cnr
R & M
23 March 1995

Flushing tap water system (continued)

4. Open valve on cooling water supply line.
5. Run HX normally for 10-15 minutes. The condenser flow is now reversed. This reverse flow will tend to loosen any deposits. Cooling performance may be less, and the water regulating valve may make some vibration noise.
6. Turn HX off.
7. Close valve on cooling water supply.
8. Restore hoses to original configuration.
9. Open valve on cooling water supply line.

Flushing with unit turned off

In either the closed facility or tap water system, it is possible to flush the condenser even if it not possible or convenient to turn the HX on. This method may be used, for example, if the HX is having other service or maintenance performed at the same time; or if electricity is not available.

It is necessary to manually open the regulating valve to allow flow through the condenser. There are two techniques.

- A. The valve may be opened by prying up the spring follower disc using two flat-blade screwdrivers, one on each side. The valve will be open as long as the spring is compressed. This is practical for a momentary opening of the valve, as it does not disturb the adjustment.

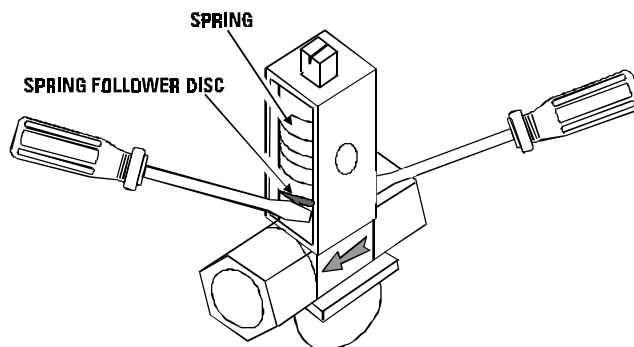

Drawing 3254.cdr
Rick V. Iles
Apr 1986

Flushing with unit turned off (continued)

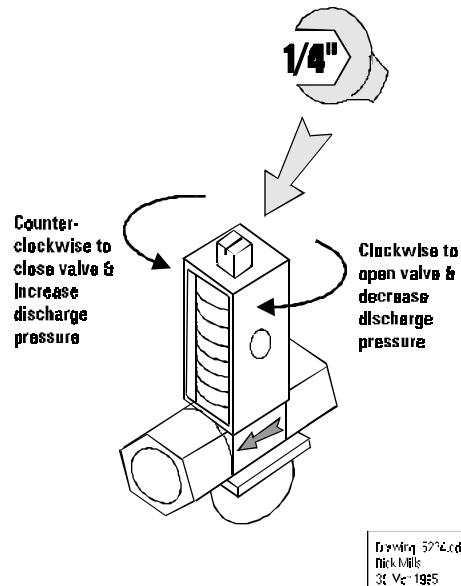

B. The second technique is to fully open the valve by turning the adjusting screw clockwise until it stops. Count how many turns are required so it may be restored later.

Commercial flushing chemicals

Commercial flushing chemicals may be used, provided the chemical is not harmful to copper. Examine and follow the container directions carefully.

HOT GAS VALVE

(also known as Automatic Discharge Relief valve)

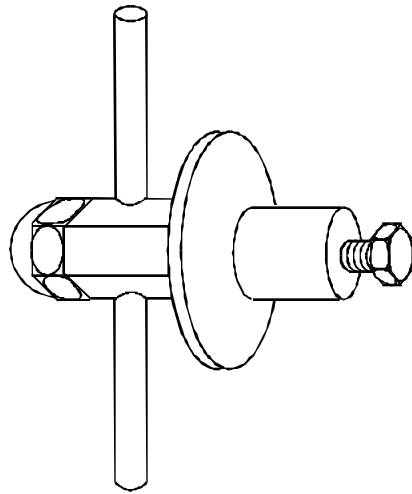

**HX100
VERTICAL TYPE**

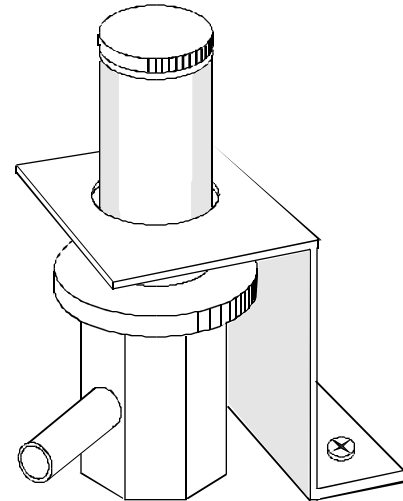

**HX150
BASE MOUNT TYPE**

The HX-100 uses a vertical-flow type hot gas valve, located near the water tank wall. The HX-150 uses a base-mount type hot gas valve, mounted near the center of the base of the unit.

OPERATION

This valve is closed during the cool cycle. When the unit switches to heat cycle, the solenoid valve in the liquid line closes, and the resulting decrease in suction pressure opens the hot gas valve. This provides a path for refrigerant gas to enter the evaporator directly without going through a liquid phase, providing a heating effect.

Hot gas valve (continued)

SETTING

Observing the suction pressure (while the unit is running in the heat/idle cycle) will indicate the setting of the hot gas valve. The valve is set correctly when the suction gauge indicates 25 PSIG for any system using R-22 refrigerant.

The setting is adjusted as shown in the illustrations. Turning the adjustment clockwise will increase the pressure setting on either type valve. Contact NESLAB Technical Service for setting specifications on systems using other refrigerants.

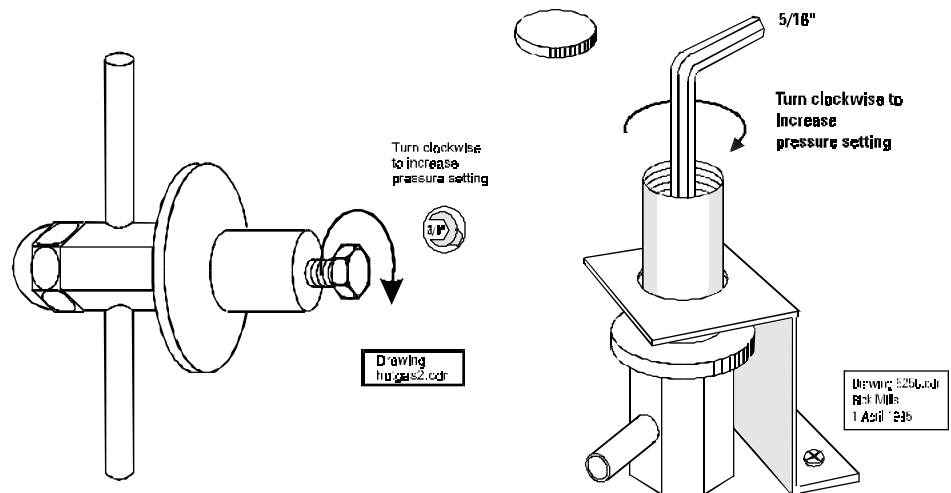

Hot Gas Valve Leak

Leak in Vertical Type

If a leak is suspected, check for leaks carefully where the adjusting screw enters the valve body. If an internal leak occurs, the refrigerant will escape along the threads of the adjusting screw. This will require replacement of the valve.

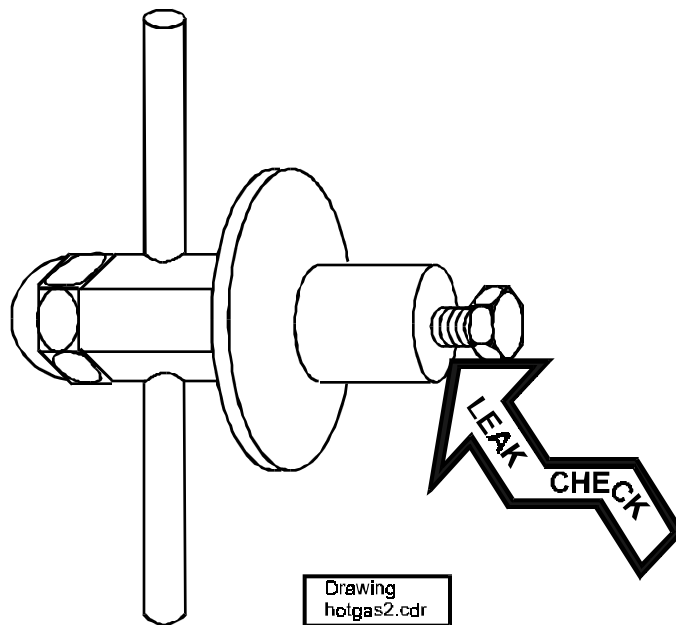

Leak In Base-Mounted Type

The base mount type may develop a leak across the diaphragm. Refrigerant will escape into the adjustment chamber. The refrigerant will be trapped in the adjustment chamber (if the dust cap is in place). Over time, the adjustment chamber pressure will rise from ambient to whatever pressure is present in the refrigeration system. The pressure across the diaphragm will equalize. The diaphragm in the valve will cease to operate correctly, as it expects to have ambient air pressure on one side.

Hot gas valve (continued)

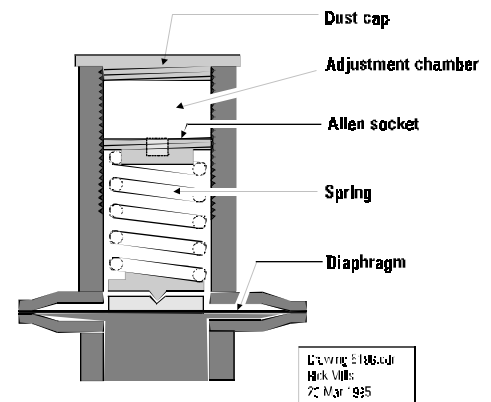

The result will be an open hot gas valve all the time. Refrigerant will flow through both heat and cool loops simultaneously. The hot gas and the liquid entering the evaporator will tend to cancel each other out. The unit will have essentially no cooling capacity at all, and the fluid temperature will tend to remain constant.

A leak can be verified as follows: Turn the unit off. Slowly unscrew the dust cap. If a leak exists, a puff of refrigerant will be observed to escape from the adjustment chamber when the cap is removed. Once the pressure is released, the valve will be able to operate normally. Start the unit and see if performance is restored. The unit can now be operated temporarily with the dust cover removed, but the leak still exists and needs repair.

Any further leak detection inside the adjustment chamber should only be done with an electronic sniffer type detector. Do not use liquid detection fluid.

RESONATION

It has been observed that certain base-mounted hot gas valves have a mechanical resonance point. If the valve is adjusted to that point, the valve will resonate with an audible whine or moaning sound whenever the unit is in the heat cycle.

If this is observed, it is recommended the setting be tweaked away from the resonance point. With the unit running in the heat cycle, turn the adjustment screw in either direction until the noise stops. Up to one complete turn in either direction is acceptable. This will not significantly change the performance of the unit.

SCHRADER VALVES

Refrigerant leaks may occur at the valve core of Schrader valves. These leaks may not be apparent due to the cover and/or any thread sealant used. NESLAB recommends leak checking all Schrader valves, especially any that have been accessed during service.

If the system is emptied of refrigerant, NESLAB recommends replacing the valve cores with new ones as a preventive measure.

If a leak is suspected but cannot be confirmed with an electronic leak detector, NESLAB recommends using a party balloon to trap any escaping refrigerant. This will provide a visual confirmation of a leak.

BALLOON TEST

1. Remove valve cover, if installed.
2. Stretch a balloon over the Schrader valve threads.
3. A leak will inflate the balloon. Leave the balloon in place overnight if convenient.

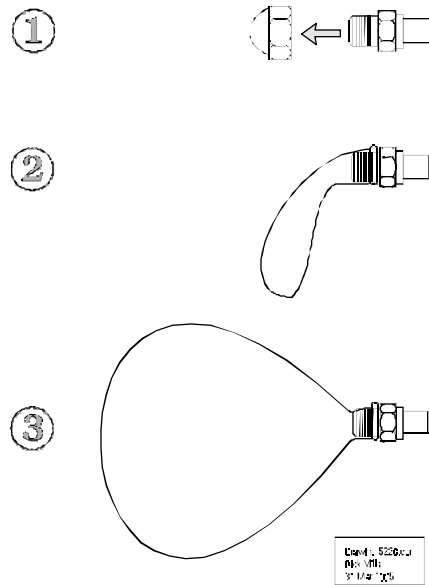

SCHRADER VALVES (continued)

4. Replace valve core if a leak is indicated, and retest.
5. Replace valve cover.
 - A. If it is the gasket type, replace with flare seal cap NESLAB part number 009121.
 - B. Inspect flare surfaces on the valve and cap. They should be smooth and free of burrs.
 - C. Apply one drop of the appropriate refrigeration oil to the flared surface of the cap to prevent galling. Do Not Over Oil - it will displace the sealant.
 - D. Apply only one drop of sealant (Perma-Lok® LM012 recommended - NESLAB partnumber 013002) to the first thread of the valve and work it around at least half way, but no more than one complete turn.
 - E. Hand tighten cap until it seats. Apply two wrenches - one on the valve body, one on the cap: and tighten $\frac{1}{4}$ turn only.
DO NOT OVERTIGHTEN!

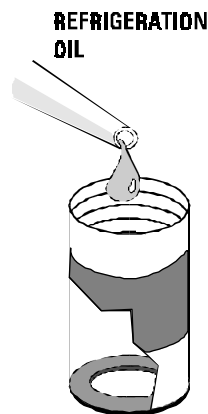

VALVE COVER
Gasket type

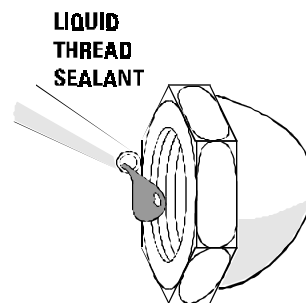

VALVE COVER
Acorn type

Drawing 5235.cdr
Rick Mills
3 Apr 1995

Solenoid Coil Test

The solenoid coil should be energized in the cool cycle (opening the solenoid valve), and off in the heat cycle.

The coil can be tested by removing the coil from the valve and sliding the coil over a screwdriver shaft. Turn unit on and adjust setpoint up and down. You should feel the coil attract the screwdriver in the cool cycle, and release in the heat cycle.

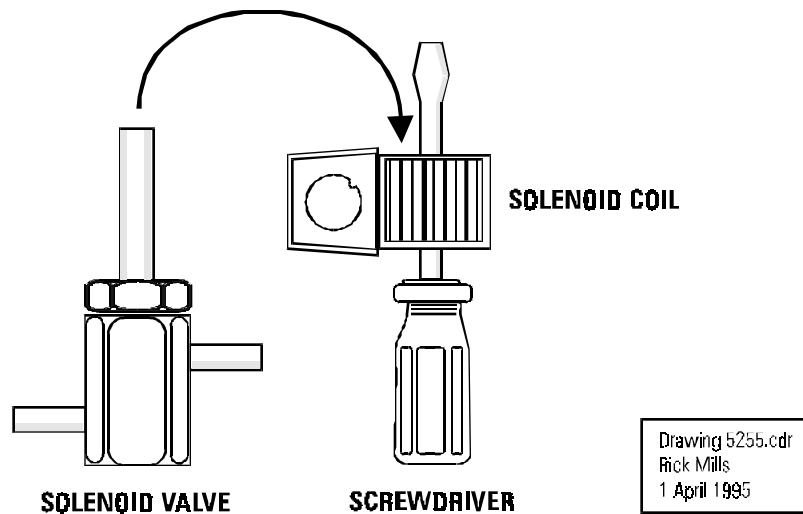

If the coil never turns on, either the coil is open or the control voltage is missing. The coil can be tested for continuity using an Ohmmeter. Turn the unit off. Unplug the coil from the wiring harness and measure the coil resistance. It should be 750 - 850 Ohms.

Replacements are available as a coil only, or a coil assembly. The assembly includes the electrical connector. Refer to the parts list for part numbers.

If a coil is obtained locally, be sure it is type OMKC-1 and rated for 208VAC. **Do not substitute a DC coil.**

Solenoid valve rebuild

NOTE: Many times the solenoid valve can be rebuilt in place, completely avoiding any brazing and greatly reducing the time needed for repair.

Rebuild procedure:

See next page for illustration.

1. Recover refrigerant.
2. Remove coil.
3. Remove large nut from valve body.
4. Remove internal valve components.
5. Inspect interior of valve body for cleanliness and lack of burrs or wear.
6. Disassemble new valve, and transfer components to the existing valve body.
7. Install large nut onto valve body.
8. Pressurize system and leak check. As the valve is normally closed, be sure that both sides of the valve are pressurized.
9. Begin evacuation of system.
10. Install coil.
11. Charge system to specification.
12. Test system.

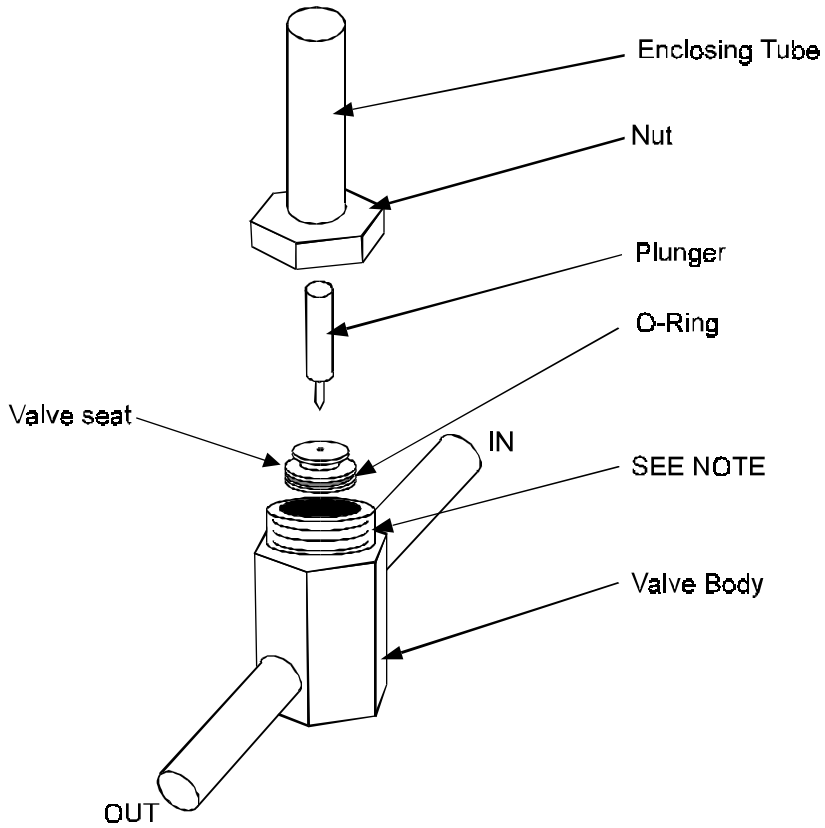

5569

Note: Apply hydraulic sealant (013002) to first two threads on valve body before tightening. Do not get sealant inside valve body!

Tank coil assembly failure

A hole developing in the evaporator of the Tank Coil Assembly can cause serious problems if not detected quickly. Once a hole occurs, refrigerant will escape into the circulating fluid. Once the refrigerant is exhausted, circulating fluid will be drawn in and contaminate the refrigeration system.

A hole in the evaporator may be recognized by a stream of (refrigerant) bubbles coming to the surface of the circulating fluid in the tank. If this is observed, it is vital to immediately shut the system down and drain the circulating fluid until it is below the level of the leak. This will prevent fluid from being drawn into the refrigeration system.

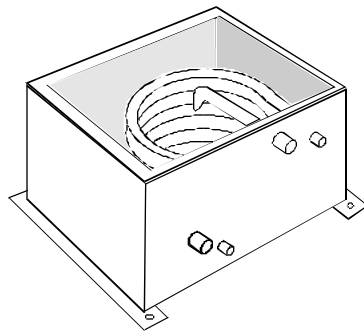

Evaporator
Type 1000
1993

Tank Coil Assembly (TCA) repair

A hole occurring in the evaporator may be repaired, provided the hole is accessible and the capacity exists to weld stainless steel. A bead of weldment can be placed over the hole. The most practical method may be to remove the TCA as outlined in the "Tank Coil Assembly (TCA) replacement" procedure, and take the TCA to a local welding shop. Advise the welder the coil is type 304 stainless steel.

If the hole is inaccessible, or no welding capability exists, the entire TCA should be replaced.

Water regulating valve setting

The correct setting of the valve is easily determined.

1. Supply cooling water to HX.
2. Direct the outlet hose into a bucket or drain.
3. Turn the HX on.
4. Turn the setpoint to minimum. The HX should enter the cool cycle. Observe full flow from the outlet hose. Allow it to run until all air is displaced.
5. Turn setpoint to maximum. The HX should enter the heat cycle.

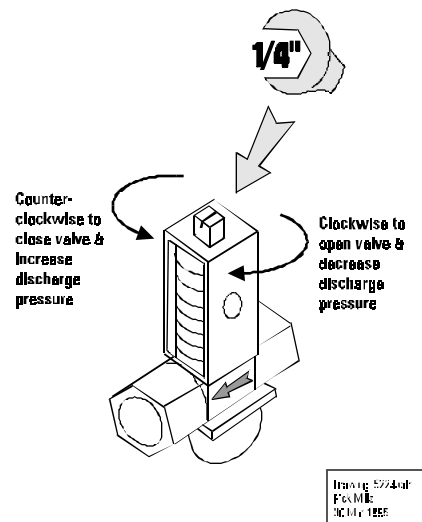

6. Adjust the valve stem closed (CCW) until the flow stops.
7. Slowly open the valve stem (CW) until a small but constant trickle is exiting the outlet hose. This is the point where the valve is just beginning to crack open. This is the correct setting.
8. Turn setpoint to minimum. The HX should enter the cool cycle. Full flow should again be observed from the outlet hose.

Refrigerant specifications

	HX100AC	HX100WC	HX150AC	HX150WC
Refrigerant	R22			
Amount	22oz	20 oz	28 oz	24 oz
Amount (metric)	624 g	567 g	794 g	680 g
Hot gas settings	25 PSIG			
Hot gas settings (metric)	172 kPa			
High pressure switch - cut in		200 PSI		200 PSI
High pressure switch - cut out		300 PSI		300 PSI
Suction pressure @ 25°C	SeeTable 1	86-92 PSIG	See Table 2	65 PSIG
Discharge pressure @ 25°C	SeeTable 1	180 PSIG	See Table 2	175 PSIG

Table 1: HX-100AC Refrigeration Pressures

Ambient °F	Ambient °C	Suction PSIG	Discharge PSIG	Speed Check °C/min
70	21.1	75-83	240-260	1.4-1.6
72	22.2	75-83	245-265	1.3-1.6
74	23.3	76-84	250-270	1.3-1.6
76	24.4	76-84	255-275	1.3-1.6
78	25.5	77-85	260-280	1.2-1.6
80	26.6	77-85	265-285	1.2-1.6

Table 2: HX-150AC Refrigeration Pressures

Ambient °F	Ambient °C	Suction PSIG	Discharge PSIG	Speed Check °C/min
70	21.1	68-81	235-265	2.1-2.6
72	22.2	70-83	240-270	2.0-2.5
74	23.3	72-85	245-275	2.0-2.5
76	24.4	74-87	250-280	2.0-2.5
78	25.5	76-89	255-285	1.9-2.4
80	26.6	78-90	260-290	1.9-2.4
82	27.7	80-91	265-295	1.8-2.3
84	28.8`	82-92	270-300	1.8-2.3

Conditions: 1. Access panels removed. 2. Water in reservoir. 3. Circulating temp 27°C (81°F). 4. Ambient measured at condenser intake.

R22 PRESSURE - TEMPERATURE CHART

PSIG	TEMP. °F
5*	-48
4*	-47
3*	-45
2*	-44
1*	-43
0	-41
1	-39
2	-37
3	-34
4	-32
5	-30
6	-28
7	-26
8	-24
9	-22
10	-20
11	-19
12	-17
13	-15
14	-14
15	-12
16	-11
17	-9
18	-8
19	-7
20	-5
21	-4
22	-3
23	-1
24	0
25	1
26	2
27	4

PSIG	TEMP. °F
28	5
29	6
30	7
31	8
32	9
33	10
34	11
35	12
36	13
37	14
38	15
39	16
40	17
42	19
44	21
46	23
48	24
50	26
52	28
54	29
56	31
58	32
60	34
62	35
64	37
66	38
68	40
70	41
72	42
74	44
76	45
78	46
80	48

PSIG	TEMP. °F
85	51
90	54
95	56
100	59
105	62
110	64
115	67
120	69
125	72
130	74
135	76
140	78
145	81
150	83
155	85
160	87
165	89
170	91
175	92
180	94
185	96
190	98
195	100
200	101
205	103
210	105
220	108
230	111
240	114
250	117
260	120
275	124
290	128

* Inches mercury below one atmosphere

Drawing 83.wks Rick Mills 5 April 1995

HEAT LOAD CALCULATION

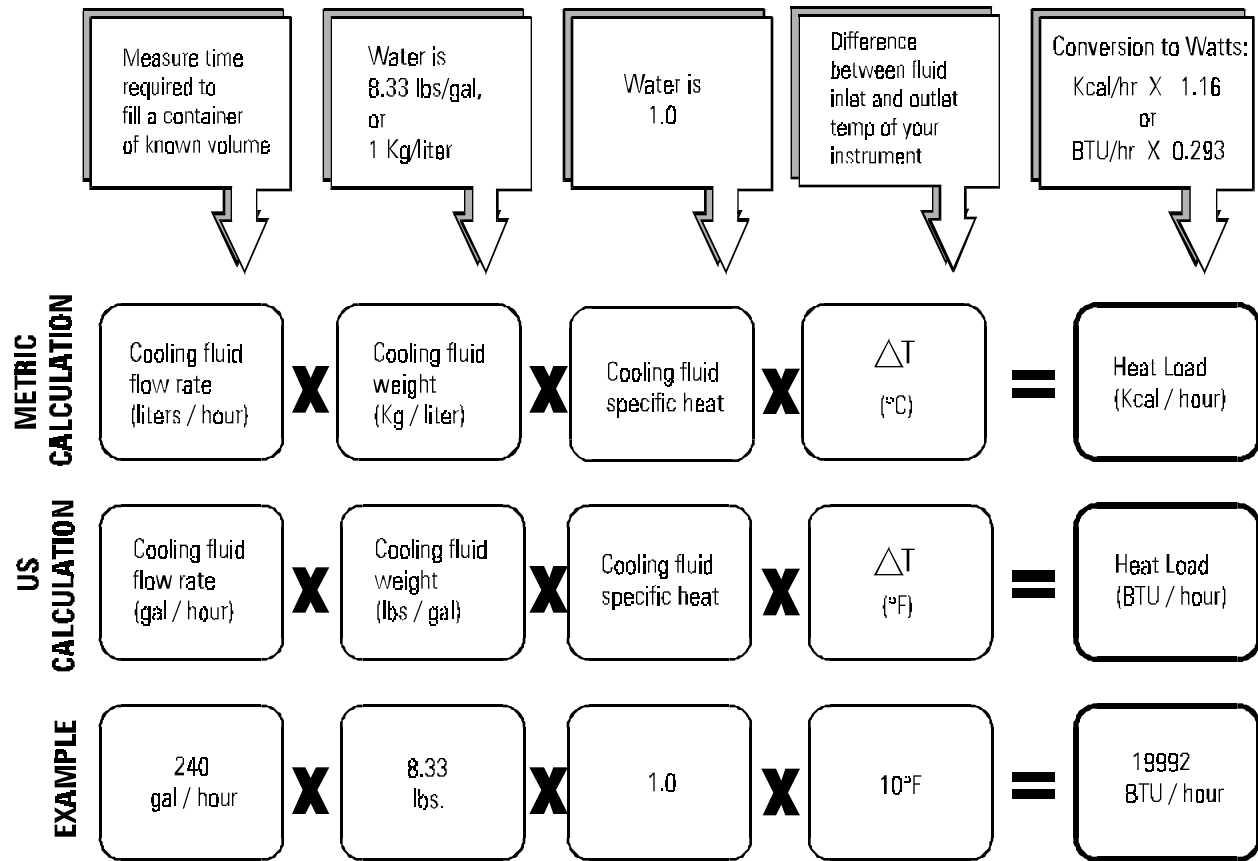

5213.00R Rick Mills 3 Apr 1995

CONDENSER REQUIREMENTS: AIR COOLED UNITS

The unit should be located in a laboratory or clean industrial environment where ambient temperatures are inside the range of +55°F to +95°F (+13°C to +35°C). The unit will retain its full rated capacity in ambient temperatures to approximately +75°F (+24°C). Above +75°F, derate the cooling capacity 1% for every 1°F above +75°F, to a maximum ambient temperature of +95°F. The Celsius deration is 1% for every 0.5 °C above 24 °C, to a maximum ambient temperature of +35°C.

The unit must be positioned so the air intake and discharge are not impeded. Air is drawn in through the left side of the unit and discharged through the right and rear. A minimum clearance of 2 feet (0.6 meter) on these three sides is necessary for adequate ventilation. Inadequate ventilation will cause a reduction in cooling capacity and, in extreme cases, compressor failure.

Excessively dusty areas should be avoided and a periodic cleaning schedule should be instituted.

Refer to the list below to determine the approximate amount of air intake required for the unit to retain its full rated capacity.

HX100: 710 cfm (20100 lpm)

HX150: 1050 cfm (29730 lpm)

CONDENSER REQUIREMENTS: WATER COOLED UNITS

The facility cooling water supply must meet or exceed the requirements shown below for the unit to operate at its full rated capacity.

As the temperature of the cooling water supply increases, the required flow and pressure of the cooling water supply increases.

Example: On the HX-150, if the temperature of the cooling water supply is 65°F (18°C), the flow rate must be at least 1.5 gpm (5.7 lpm), with a pressure differential of at least 3.5 psi (24 kPa). However, if the temperature of the cooling water supply rises to 85°F (29°C), the flow rate must be at least 4.0 gpm (15 lpm), with a pressure differential of at least 10 psi (69 kPa).

A water regulating valve, located in TAP WATER line, regulates the flow rate of the cooling water supply as it enters the unit. The valve regulates the flow rate based on the heat load. Flow through the unit stops automatically when the unit is shut off.

	55°F (13°C)	65°F (18°C)	75°F (24°C)	85°F (29°C)
HX 100				
Required flow - gpm	1.0	1.5	2	3.5
Required flow - lpm	3.7	5.7	7.6	13.2
Required pressure drop - PSI	2	3.5	5.0	10
Required pressure drop - BAR	0.13	0.24	0.34	0.69
Required pressure drop - kPa	13	24	34	69

	55°F (13°C)	65°F (18°C)	75°F (24°C)	85°F (29°C)
HX 150				
Required flow - gpm	1.0	1.5	2.5	4
Required flow - lpm	3.7	5.7	9.5	15.1
Required pressure drop - PSI	2	3.5	6	10
Required pressure drop - BAR	0.13	0.24	0.41	0.69
Required pressure drop - kPa	13	24	41	69

15 pin Accessory Connector (Optional)

Units with digital controllers may be modified with a 15 pin accessory connector. To enable the connector slide the LOCAL/REMOTE switch on the temperature controller to the REMOTE position. The pin out information is listed below.

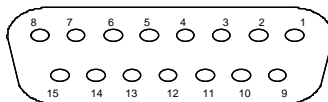

15 pin D-subminiature female receptacle

Pin # Function

1	Chassis ground.
2	No connection.
3	Span +. Indicates the maximum setpoint value the unit can be set to operate. The temperature scale is 10mV/°C, referenced to analog ground, pin 6 (example: +350mV = +35.0°C).
4	Span -. Indicates the minimum setpoint value the unit can be set to operate. The temperature scale is 10mV/°C, referenced to analog ground, pin 6 (example: +50mV = +5.0°C).
5	No connection.
6	Analog ground. The analog ground is physically separated from the power ground throughout the unit. To prevent offsets that result from ground currents, the analog and power grounds are only connected at the unit's power supply. Analog ground should only be used as a reference pin .
7	Sensor temperature (current limited through 2.7K OHM resistor). The fluid temperature, as measured by the controller's sensor located in the reservoir, can be read at this pin. The temperature scale is 10mV/°C, referenced to analog ground, pin 6 (example: +150mV = +15.0°C).
8	Setpoint out. The present temperature setpoint can be read at this pin. The temperature scale is 10mV/°C, referenced to analog ground, pin 6 (example: +150mV = +15.0°C).
9	Power Ground.
10	Heater output. Will source 3V at 6mA.
11	No connection.
12	Digital display (input only). An external voltage can be displayed on the operator panel digital display by applying the voltage to this pin. The display has a low input resistance and a full scale rating of ±1.99VDC. Input is referenced to analog ground, pin 6. The maximum voltage applied to the display should be limited to 2VDC.
13	- 5V. Power supply of -5VDC (15mA maximum).
14	+5V. Power supply of +5VDC (15mA maximum).
15	Setpoint in. The temperature setpoint can be controlled by applying a known voltage to this pin. The temperature scale is 10mV/°C, referenced to analog ground, pin 6 (example: +230mV = +23.0°C).

HX-100 & HX-150 Parts list

PART	HX-100 AIR COOLED	HX-100 WATER COOLED	HX150 AIR COOLED	HX-150 WATER COOLED
ADR valve	See Hot Gas Valve	See Hot Gas Valve	See hot gas valve	See Hot Gas Valve
Capillary Tube	012116	012116	012116	012116
Compressor 230/60	Part of Condensing Unit	007159	Part of Condensing Unit	007157
Compressor 220/50	Part of Condensing Unit	007484	Part of Condensing Unit	007153
Condensing Unit 230/60	007464		007463	
Condensing Unit 220/50	007480		007479	
Evaporator	See Tank Coil Assy.	See Tank Coil Assy.	See Tank Coil Assy.	See Tank Coil Assy.
Fan blade	Part of Condensing Unit	007663	Part of Condensing Unit	007663
Fan motor	Part of Condensing Unit	007402	Part of Condensing Unit	007402
Filter/Dryer	009363	009363	009363	009363
Hot Gas Valve	009298	009298	009137	009137
Solenoid coil (assembly) liquid line	051694	051694	051694	051694
Solenoid coil (only) liquid line	009476	009476	009476	009476
Solenoid Valve Liquid Line	009475	009475	009475	009475
Suction Filter	009325	009325	009325	009325
Tank/Coil Assembly	052950	052950	052950	052950
Casters (locking)	013053	013053	013687	013058
Casters (Non-locking)	013111	013111	013686	013057
Refrigerant	R-22	R-22	R22	R-22