

C7B6	A	ADDED: GND TO 1PWS AND 2MTR; VARIOUS WIRE NOS. . . COLORS AND GAGES; P/J6-1,2; P/J5-1	3-18-98	BAJ	DS	DS
A8	B	ADDED: GROUND TO 1TAS; WIRE NUMBERS TO 1PWS L1 AND L2 WIRES. CHANGED: "SYSTEM ON" WAS "PUMP STATUS"; WIRE NUMBER 2L1-1 WAS 2L1-2; NOTE-3 WAS "LAST WIRE NUMBER '15 152'"; PCO 11652	6-5-98	BAJ	AK	LG
C4A7	C	CHANGED: TB2 WAS 2TB; P/J5-2 WAS P/J4-3; 1L1,2,3 WAS BLK,2,1; 12L3 WAS 1L3. PCO 10653	7-15-99	BAJ	CLG	CAD
A7	D	CHANGED: 2C1 P/N WAS Q14687; J25 WAS 006669. ECO 13743	9-7-99	BAJ		CAD
A6, B	E	ADDED: 1,2CBL, P/J4-6, P/J8,9 TO P/L: P/J7-1,2 TO WIRING OF 3FS; 1TAS CONN. POINT NUMBERS. CHANGED: 1LT P/N WAS 005663; 2LT WAS 000411; 1RS 005604; WIRE #10-9 WAS TO 3FS WIRE #10-6 RED. ECO 14056	11-5-99	BAJ	JCH	CWC
A7, B	F	CHANGED: 1TAS WAS SHOWN "OPEN ON RISE". DELETED: 3SOL GROUND WIRE. ECO 15741 CHANGED: 1CRE PART NUMBER WAS 010753; 1CRE CONNECTION POINT "NO." WAS "3" AND "COM" WAS "4". ECO 15617	1-30-01	BAJ	RBL	APC
C4A6	G	ADDED: 1TB TO WIRE #9L3, 12L3, 15-18; CONNECTION POINT TEXT TO 1CON, 1,2MOL; VARIOUS WIRE NUMBERS AND COLORS. ECO 17052	8-02-02	BAJ		

- NOTES:
1. ALL WIRES ARE #18 AWG UNLESS OTHERWISE SPECIFIED.
 2. SHOWN IN TWO PLACES, SHEETS 1 AND 2.
 3. LAST WIRE NUMBER USED IS 155.
 4. DIAGRAM PARTS LIST USED AS REFERENCE ONLY.

P8,9	CONNECTOR, PLUG	001565	9 PIN, CPC
P4-6	CONNECTOR, PLUG	006101	2 PIN, M & L
J25	CONNECTOR, JACK	006555	15 PIN, D
J8,9	CONNECTOR, JACK	024130	9 PIN, CPC
J4-6	CONNECTOR, JACK	006100	2 PIN, M & L
1TAS	TEMPERATURE ACTUATED SWITCH	006440	
1T	TRANSFORMER, CONTROL	014517	208/24/24, 8/158VA
1SS	SELECTOR SWITCH, ON/OFF	000241	
3SOL	SOLENOID VALVE, ANTI-SIPHON	008700	
1,2SOL	SOLENOID	009116	208VAC, MKC1
1RTD	RESISTIVE TEMPERATURE DEVICE	000500	100 OHM
1RS	RESISTIVITY SENSOR	026521	K=0.1
2RECP	RECEPTACLE, ITLK EXTERNAL EMO	010187	
1RECP	RECEPTACLE	000689	250V, 50A
1PX	PRESSURE TRANSDUCER	008995	
1PWS	POWER SUPPLY	001185	24V DC
1PB	PUSH BUTTON, EMERGENCY OFF	001696	
3MTR	MOTOR, PUMP #2	024928	5 HP
2MTR	MOTOR, VALVE ACTUATOR	014744	1", 6-9V
1MTR	MOTOR, PUMP #1	024928	5 HP
1,2MOL	MOTOR OVERLOAD	006520	10-16A
2LT	PILOT LIGHT, AMBER	005663	24VAC
1LT	PILOT LIGHT, WHITE	000411	24VAC
4INST	INSTRUMENT, RS-232 CARD	000242.1B	
3INST	INSTRUMENT, RESISTIVITY CARD	005844.2A	
2INST	INSTRUMENT, DIGITAL I/O CARD	005845.2B	
1INST	INSTRUMENT, CONTROLLER IV	005843.2E	
1FX	FLOW TRANSDUCER	024677	10-60 GPM, 1"
1-3FS	FLOAT SWITCH	005599	POLY-PRO
7,8FU	FUSE, CONTROLLER IV	010881	1/2A, 250V, FNM
6FU	FUSE	010882	2A, 250V, FNM
4,5FU	FUSE, SOLENOID VALVES	010855	1A, 250V, FNM
1-3FU	FUSE, PHASE MONITOR	000353	2A, 600V, NTD
1DAS	DIODE ARC SUPPRESSOR	000239	48V
1CRE	CONTROL RELAY ELECTRONIC	082512	PHASE MONITOR, 230V
1-SCR	CONTROL RELAY	000546	
1CON	CONTACTOR, PUMP	000940	3P+1, 24VAC, 20A
3,4CI	CIRCUIT INTERRUPTER, PUMP	005808	20A
2CI	CIRCUIT INTERRUPTER	024768	3/4A
1CI	CIRCUIT INTERRUPTER, MAIN	005807	30A
1,2CBL	CABLE	006528	22AWG, 4C

JOL IN	1-23-98
GRANT	1-26-98
GRANT	1-26-98

AS LISTED SYSTEM V CONTROL (DIGITAL)

D	6.3538	G
6.3240		1 OF 2



FOR SALES AND SERVICE PLEASE CALL:
PTB SALES T :: 866.332.0500
 F :: 626.334.2151
www.ptbsales.com

DATE SERVICED: _____

VIEW OUR INVENTORY

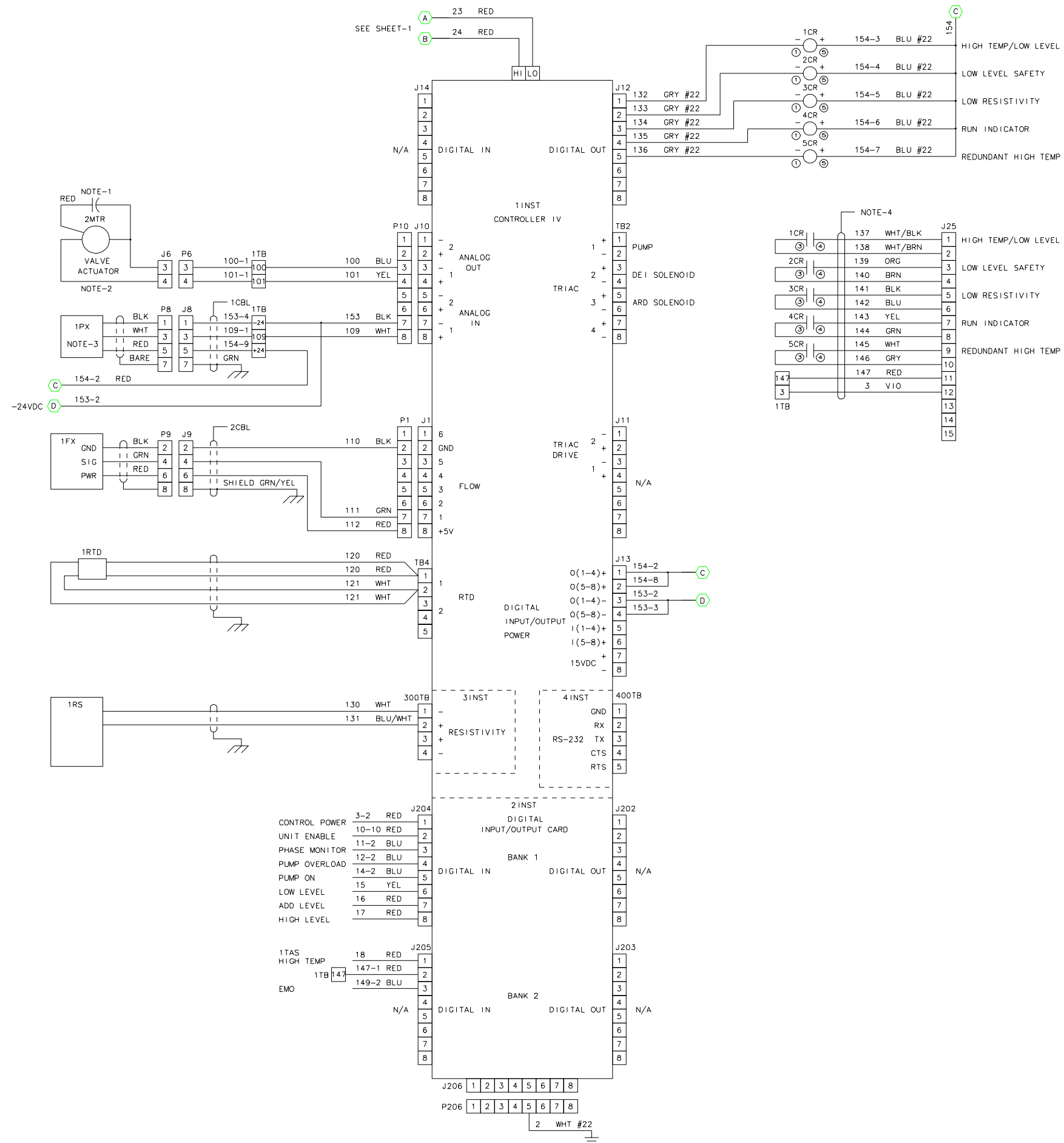

REV	DESCRIPTION	DATE	BY	CHK	APP
A	ADDED: VARIOUS WIRE NOS., COLORS AND GAGES; NOTE-4; P/J6 BETWEEN P10 AND 2MTR. CHANGED: TB4 WAS 4TB; TB2 WAS 2TB; 111 GRN WAS 111 CLR. PCO 10653	3-18-98	BAJ	LG	LG
B	ADDED: NOTE-5. PCO 11652	6-5-98	BAJ	AK	LG
C	NO CHANGES. SEE SHEET-1 FOR REVISION. ECO 13743	7-15-99	BAJ	CLG	CAD
D3	DELETED: NOTE-5 WAS "J25 IS AN IDC MALE CONNECTOR". ECO 13971	9-7-99	BAJ	---	CAD
E	ADDED: P/J8; P/J9; "22AWG, 15C" TO NOTE-4. CHANGED: WIRE NO. 131 WAS BLK. ECO 14056	11-5-99	BAJ	JCH	CWC
F	NO CHANGES. SEE SHEET-1 FOR REVISION. ECO 15741 & ECO 15617	1-30-01	BAJ	RBL	APC
G	ADDED: 1TB TO WIRE #100, 101, 109, 153. 154-9. CHANGED: 1TB-147 WAS J205-2; 1TB-3 WAS J204-1; 1TB-147 WAS J25-11; WIRE NUMBERS TO 11INST-J13. ECO 17052	8-02-02	BAJ		

- NOTES:
- CAPACITOR KIT INCLUDED WITH MOTORIZED VALVE.
 - SHOWN IN TWO PLACES, SHEETS 1 AND 2.
 - SHIELDED CABLE USED.
 - CABLE USED IS P/N 006697, 22 AWG, 15C.

JOLIN 1-23-98
 GRANT 1-26-98
 GRANT 1-26-98