

Varian Vacuum Technologies
121 Hartwell Avenue
Lexington, MA 02421-3133
(781) 861-7200
(800) 8-VARIAN

VHS-10 & VHS-400 Diffusion Pumps

Instruction Manual



For sales and service please call:

PTB Sales

Ph. (626) 334-0500

Fax (626) 334-2151

Toll Free 866-332-0500

www.ptb-sales.com



VARIAN

Manual No. 6999-01-023
Revision H
October 2000



Sales and Service Offices

United States

Varian Vacuum Products
121 Hartwell Avenue
Lexington, MA 02421
USA
Tel: (781) 861 7200
Fax: (781) 860 5437
Toll Free: 1 (800) 882 7426

Argentina

Varian Argentina Ltd.
Sucursal Argentina
Av. Ricardo Balbin 2316
1428 Buenos Aires
Argentina
Tel: (54) 1 783 5306
Fax: (54) 1 786 5172

Australia

Varian Australia Pty., Ltd.
6/81 Frenchs Forest Road
Frenchs Forest, NSW 2086
Australia
Tel: (61) 2 9451 9133
Fax: (61) 2 9452 2600

Brazil

Varian Industria e Comercio Ltda.
Avenida Dr. Cardoso de Mello 1644
Vila Olimpia
Sao Paulo 04548 005
Brazil
Tel: (55) 11 820 0444
Fax: (55) 11 820 9350

Canada

Varian Canada, Inc.
6705 Millcreek Drive, Unit #5
Mississauga, Ontario L5N 5R9
Canada
Tel: (905) 819 8188
Fax: (905) 819 8348

China

Varian China Ltd.
2nd Floor, Meeting Center
Beijing Medical University
38 Xue Yuan Road
Beijing 100083
China
Tel: (86) 10 6209 1394
Fax: (86) 10 6209 1735

Varian Shanghai Service Station

716 Yishan Road Shanghai
P.R. China 200233
Tel: (86) 21 6483 5576
Fax: (86) 21 6485 9031

England

Varian Ltd.
28 Manor Road
Walton-On-Thames
Surrey KT 12 2QF
England
Tel: (44) 1932 89 8000
Fax: (44) 1932 22 8769

France

Varian s.a.
7 Avenue des Tropiques
Z.A. de Courtaboeuf – B.P. 12
Les Ulis Cédex (Orsay) 91941
France
Tel: (33) 1 69 86 38 38
Fax: (33) 1 69 28 23 08

Germany

Varian GmbH
Alsfelder Strasse 6
Postfach 11 14 35
64229 Darmstadt
Germany
Tel: (49) 06151 703 205
Fax: (49) 06151 703 279

Hong Kong

Varian Pacific Inc.
Rm 1018-20, Tower A
New Mandarin Plaza
14 Science Museum Rd.
Tsimshatsui East, Kowloon
Hong Kong
Tel: (852) 2724 2836
Fax: (852) 2369 4280

India

Varian International AG
605/606, Vishwadeep Towers
4 District Centre
Janak Puri
New Delhi 110 058
India
Tel: (91) 11 561 1442
Fax: (91) 11 552 4317

Italy

Varian S.p.A.
Via Flli Varian 54
10040 Leini, (Torino)
Italy
Tel: (39) 11 997 9111
Fax: (39) 11 997 9350

Japan

Varian Japan KK
Sumitomo Shibaura Building
4-16-36 Shibaura
Minato-ku, Tokyo 108
Japan
Tel: (81) 3 5232 1211
Fax: (81) 3 5232 1263

Korea

Varian Technologies Korea, Ltd
Shinsa 2nd Bldg. 2F
966-5 Daechi Dong
Kangnam Gu, Seoul
Korea 135-280
Tel: (82) 02 3452 2452
Fax: (82) 02 3452 2451

Mexico

Varian S.A.
Concepcion Beistegui No 109
Col Del Valle 03100
Mexico, D.F.
Tel: (52) 5 523 9465
Fax: (52) 5 514 5383

Singapore

Varian Asia, Ltd.
1123 Serangoon Road
#03-02
Singapore 328207
Tel: (65) 296 9688
Fax: (65) 296 9733

Taiwan

Varian Pacific Inc., Taiwan Branch
18F-13 No.79, Hsin Tai Wu Road
Sec. 1, Hsi Chih
Taipei Hsien
Taiwan
Tel: (886) 2 6989555
Fax: (886) 2 6989678

Representatives in most countries

Internet Users

customer.service@vpl.varian.com

Also see Varian's Home Page at:
www.vvp.varian.com

WARRANTY

Products manufactured by Seller are warranted against defects in materials and workmanship for twelve (12) months from date of shipment thereof to Customer, and Seller's liability under valid warranty claims is limited, at the option of Seller, to repair, replacement, or refund of an equitable portion of the purchase price of the Product. Items expendable in normal use are not covered by this warranty. All warranty replacement or repair of parts shall be limited to equipment malfunctions which, in the sole opinion of Seller, are due or traceable to defects in original materials or workmanship. All obligations of Seller under this warranty shall cease in the event of abuse, accident, alteration, misuse, or neglect of the equipment. In-warranty repaired or replacement parts are warranted only for the remaining unexpired portion of the original warranty period applicable to the repaired or replaced parts. After expiration of the applicable warranty period, Customer shall be charged at the then current prices for parts, labor, and transportation.

Reasonable care must be used to avoid hazards. Seller expressly disclaims responsibility for loss or damage caused by use of its Products other than in accordance with proper operating procedures.

Except as stated herein, Seller makes no warranty, express or implied (either in fact or by operation of law), statutory or otherwise; and, except as stated herein, Seller shall have no liability under any warranty, express or implied (either in fact or by operation of law), statutory or otherwise. Statements made by any person, including representatives of Seller, which are inconsistent or in conflict with the terms of this warranty shall not be binding upon Seller unless reduced to writing and approved by an officer of Seller.

Warranty Replacement and Adjustment

All claims under warranty must be made promptly after occurrence of circumstances giving rise thereto, and must be received within the applicable warranty period by Seller or its authorized representative. Such claims should include the Product serial number, the date of shipment, and a full description of the circumstances giving rise to the claim. Before any Products are returned for repair and/or adjustment, written authorization from Seller or its authorized representative for the return and instructions as to how and where these Products should be returned must be obtained. Any Product returned to Seller for examination shall be prepaid via the means of transportation indicated as acceptable by Seller. Seller reserves the right to reject any warranty claim not promptly reported and any warranty claim on any item that has been altered or has been returned by non-acceptable means of transportation. When any Product is returned for examination and inspection, or for any other reason, Customer shall be responsible for all damage resulting from improper packing or handling, and for loss in transit, notwithstanding any defect or non-conformity in the Product, in all cases, Seller has the sole responsibility for determining the cause and nature of failure, and Seller's determination with regard thereto shall be final.

If it is found that Seller's Product has been returned without cause and is still serviceable, Customer will be notified and the Product returned at its expense; in addition, a charge for testing and examination may be made on Products so returned.

OPERATION AND MAINTENANCE OF THIS EQUIPMENT INVOLVES SERIOUS RISK. IT IS THE RESPONSIBILITY OF THE USER TO MAINTAIN SAFE OPERATING CONDITIONS AT ALL TIMES. VARIAN ASSUMES NO LIABILITY FOR PERSONAL INJURY OR DAMAGE RESULTING FROM OPERATION OR SERVICE OF THE EQUIPMENT.

Carelessly or improperly operated equipment can cause serious injury or death and/or damage to the equipment. The emergency and safety procedures in this manual are provided to help users and qualified persons to operate and service the unit safely. Recommendations are believed to reflect accepted industry practices in effect on the date of publication of this manual. Special applications must be reviewed and approved by an industrial hygienist or chemical safety engineer.

Varian has no control over the use of this equipment and is not responsible for personal injury or damage resulting from its use. The safe use and disposal of hazardous or potentially hazardous materials of any kind is the sole responsibility of the user. Observe all WARNINGS and CAUTIONS to minimize the serious hazards involved.

It is the sole responsibility of users of Varian equipment to comply with all local, state, and federal safety requirements (laws and regulations) applicable to their system. Employ the services of an industrial hygienist and/or a qualified chemical safety engineer in order to ensure safe installation and use.

This instruction manual contains information which will assist qualified operators in the operation, and qualified service engineers to carry out field-servicing the Varian equipment.

SAFE INCORPORATION OF VARIAN DIFFUSION PUMPS INTO VACUUM SYSTEMS IS THE RESPONSIBILITY OF THE SYSTEMS DESIGNER. TAKE APPROPRIATE ACTION THROUGH REDUNDANCY, AND/OR OTHER SAFEGUARDS TO PROTECT PERSONNEL AND PROPERTY FROM THE HAZARDS DESCRIBED BELOW AND IN THE INSTALLATION, OPERATION, AND MAINTENANCE INSTRUCTION MANUAL. SAFE OPERATION IS THE RESPONSIBILITY OF THE USING ORGANIZATION AND ITS PERSONNEL. READ THE INSTRUCTION MANUAL AND UNDERSTAND HOW TO AVOID HAZARDS PRIOR TO OPERATING THE DIFFUSION PUMP. ALL PERSONS WHO WORK WITH OR ARE EXPOSED TO DIFFUSION PUMPS OR EQUIPMENT WHICH UTILIZES SUCH PUMPS OR DIFFUSION PUMP FLUID MUST TAKE PRECAUTIONS TO PROTECT THEMSELVES AGAINST POSSIBLE SERIOUS BODILY INJURY OR DEATH. DO NOT BE CARELESS AROUND SUCH PRODUCTS.

THESE SHEETS AND THE INSTALLATION, OPERATION, AND MAINTENANCE INSTRUCTIONS CAN HELP YOU TO OPERATE THIS PUMP SAFELY AND EFFICIENTLY. READ THEM. SPECIAL OPERATING CONSIDERATIONS AND PRECAUTIONS WILL BE FOUND IN THE OPERATION INSTRUCTIONS. UNINFORMED OR CARELESS OPERATION OF THIS PUMP CAN RESULT IN POOR PERFORMANCE, DAMAGE TO THE PUMP OR OTHER PROPERTY, SERIOUS BODILY INJURY, AND POSSIBLE DEATH.

USERS OF THIS EQUIPMENT SHOULD BE ALERT TO TWO LEVELS OF HAZARDS IDENTIFIED BY THE FOLLOWING SYMBOLS:

 WARNING
Warnings are used when failure to observe instructions or precautions could result in injury or death to humans.

 CAUTION
Cautions are used when failure to observe instructions could result in significant damage to equipment and/or facilities.

Designers of systems which utilize diffusion pumps must design out hazards wherever possible; provide guards, safety features, and interlocks for hazards which cannot be designed out; warn with respect to hazards which cannot be designed out and which remain after utilizing guards, safety features, and interlocks; and lastly, provide procedures and instructions on proper use, servicing, etc., so as to minimize risk.

THE INSTALLATION, OPERATION, AND/OR SERVICING OR DIFFUSION PUMPS INVOLVES ONE OR MORE OF THE FOLLOWING HAZARDS, ANY ONE OF WHICH, IN THE ABSENCE OF SAFE OPERATING PRACTICES AND PRECAUTIONS, COULD POTENTIALLY RESULT IN DEATH OR SERIOUS HARM TO PERSONNEL.

Hazard	Suggested Corrective Action
Loss of utility: water and/or electricity	Provide sufficient water and backup power to effect a safe shutdown under worst case conditions.
Overpressure in foreline	Provide an interlock to ensure that the power supply to the pump heater cannot be activated if the foreline pump is not running AND/OR pressure in foreline is above 0.5 Torr (66.5 Pa).
Overtemperature	Fit temperature sensors and pump fluid level sensors with feedback to an interlock on the heater power supply.
Insufficient water flow through the main cooling coils	Use water flow sensor and feedback to interlock on the heater power supply.
Water trapped between inlet and outlet of quick-cool coil, or liquid nitrogen trapped between inlet and outlet of liquid nitrogen trap	Provide vent or pressure relief valves for both quick-cool coil and liquid nitrogen trap.
Loss of ground integrity	Incorporate ground fault interrupt circuit into heater power supply.
Positive pressure in pumping system	Integrate pressure relief valve in vacuum system.
High voltage (up to 480 V)	Prevent personnel contact with high voltages; design and attach warnings.
Toxicity/Corrosivity	Toxic and/or corrosive gases must be vented to a safe location, ensuring adequate dilution or scrubbing to safe levels, taking all action required to meet air quality standards.

Hazard	Suggested Corrective Action
Explosion	Integrate pressure relief valves in all systems using pumps 10 inches or larger in diameter. Do not use or recommend the use of hydrocarbon-based pumping oils.

- a. **Explosion** – Operation of the diffusion pump without prior and continuous evacuation (below 0.5 Torr (66.5 Pa)) or coolant and introducing a strong oxidizer (such as air) or explosive vapors or powders or materials which may react with pumping fluids into a hot (above 300°F or 150°C) pump can cause an explosion. Such an explosion can violently expel valves and other hardware, slam open doors that are not designed for appropriate pressure relief, or burst other components of the vacuum system. Serious injury or death may result from expelled parts, doors, shrapnel, and/or shock waves.
- b. All diffusion pumps are typically cleaned with acetone or alcohol. When combined with air, oxygen, and other oxidizers, alcohol and most other solvents are very flammable and explosive. Never permit any trace of these cleaners to remain in or on the pump. Always remove all traces of alcohol and acetone and other cleaners with clean, dry, oil-free compressed air.

Three elements are required: fuel, oxidizer, and source of ignition. A combination of temperature and pressure can be a source of ignition. Most diffusion pump fluids except mercury are fuels. Hydrocarbon oils are more prone to oxidize and explode than synthetic silicone-based oil. Oxidizers can be air (a strong oxidizer) from a leak or can be deliberately introduced in a process or can be inadvertently admitted to the system by operator or process controller error. Oxygen and other strong oxidizers are even more dangerous. Certain conditions of temperature and pressure can cause a combustible mixture to explode. The larger the diffusion pump, the greater the risk of explosion and the greater the risk of damage and/or injury. Never operate diffusion pumps larger than 10 inches in diameter with hydrocarbon oils without a full safety analysis for the complete system and application. Never operate any diffusion pump in the following ways because they increase the probability of an explosion.

Prohibited Action	Explosion-Causing Condition
Run pump with no cooling water	Overtemperature
Run pump with low level of pump fluid	Overtemperature
Run pump without proper backing or holding pump	Overpressure
Run pump when not evacuated below 0.5 Torr	Overpressure
Admit air to, or rough through, a pump with hot boiler	Overpressure plus strong oxidizer

Prohibited Action	Explosion-Causing Condition
Open drain or fill plug while pump is under vacuum, especially when it is hot	Overpressure plus strong oxidizer
Contaminate pump with explosive vapors, powders, or reactive materials	Lower explosive threshold of gas mixtures
Remove, defeat, or override safety countermeasures such as pressure and thermal switches and valve sequencer interlocks	Overtemperature, overpressure, more combustible mixtures
Machine or weld without removing all oil or solvent residue in pump	Source of ignition
Use unsuitable pumping fluid especially in large pumps	Lower explosive threshold of gas mixture

Systems larger than 10 inches must be designed with pressure relief devices to provide safe pressure relief from internal explosions. Always recognize that safety devices can fail or malfunction. Provide redundant protection by installing devices having different failure modes, failure mechanisms, and failure causes. Be certain that exhaust duct materials are capable of withstanding the corrosivity, temperature, and pressure of exhausted products.

- c. **Pressure** – Pumps and their components are designed for vacuum service; they are not designed to be pressurized which could cause them to burst possibly expelling shrapnel at lethal velocities. Serious accidents have been caused by intentional pressurization of vacuum systems and their components. **Never pressurize any part of a vacuum system for test or any other purpose.** Always provide pressure relief when designing diffusion pumps into systems and ensure that pressure relief motion is limited to safe envelopes. Never permit the following:

Prohibited Action	Result
Block inlet and vent of liquid nitrogen trap and lines	LN ₂ trap and/or lines burst
Close isolation valves at inlet and discharge of main watercooling coils and pump is reheated	Water turns to steam and bursts coils
Pressurize pump body	Body of pump bursts
Hole through vacuum wall	Loss of structural integrity of wall

- d. **Poisonous and/or Corrosive Compounds** – When pumping poisonous, reactive, and/or corrosive gas, vapors, or chemicals, even proper operation and regeneration will not always ensure that all hazardous materials have been totally removed. If hazardous gas, vapors, chemicals, or combustible mixtures are pumped, sufficient quantities may exist during operation or remain after regeneration to cause severe injury or death. Overheating the pump oil, exposing it to air or reactive materials, or overpressurizing it above the normal operating range (approximately 1mTorr (.133 Pa)) will decompose the oil and possibly make it toxic. This is especially true of backstreamed mechanical pump oils which are more volatile (unstable). Overheating of accidentally introduced or backstreamed mechanical pump oils cannot be protected against by thermal switches which are set for diffusion pump oil.

Refer to specific instruction manuals for detailed instructions and precautions. Always vent the pump and relief valve to a safe location thus ensuring adequate dilution to safe levels, and take all other action required to meet quality air standards. Always handle pump fluids and hardware with an awareness of the possible deadly hazards involved and the necessity for great care and attention to safety precautions.

Diffusion pumps are typically cleaned with acetone or alcohol. Acetone, alcohol, and most other solvents are irritants, narcotics, and depressants, and/or carcinogenic. Their inhalation and ingestion may produce serious effects. Even absorption through the skin can result in moderate toxicity. Always ensure that cleaning operations are performed in large, well-ventilated rooms. Use of self-contained breathing apparatus may be necessary depending upon the solvent type and vapor concentration in surrounding air.

- e. **High Voltage** – Diffusion pumps operate at voltages (up to 480 V) high enough to kill through electrical shock. Design equipment utilizing these pumps to prevent personnel contact with high voltages. Securely attach prominent hazard warnings. Personnel should always break the primary circuit to the power supply when direct access to the heater or wiring is required.
- f. **Hot Surfaces** – Boiler temperatures reach 530°F (275°C) which can cause serious burns when touched. Always ensure that surfaces have cooled near room temperature before touching them.
- g. **Hot Coolant and/or Steam** – The water used to cool the pump can reach scalding temperatures. Touching or rupture of the cooling surface can cause serious burns. Water left inside quick cool coils from previous use will turn to steam when the pump is reheated. This steam must be allowed to escape without contacting personnel. Whenever possible, design the water system with interlock valves so that power cannot be applied to the pump unless water is flowing in the main cooling coils (not quick-cooling coils).
- h. **Cold Surfaces** – Liquid nitrogen traps cooled by liquid nitrogen are commonly used in diffusion pumps. Metal surfaces at liquid nitrogen temperature can cause severe frostbite if contacted by unprotected skin. These surfaces remain cold for some time (at least a half hour) after the liquid nitrogen has evaporated.

- i. **Cold Coolant** – Liquid nitrogen, a cryogenic liquid, is used in traps. If it is splashed on body tissues or eyes, it can cause severe frostbite or blindness. The extremely low temperature of liquified nitrogen can cause skin damage similar to high temperature burns. Contact with the cold gas evolving from the liquid may produce the same effect. Delicate tissues, such as the eye tissues, are most easily damaged by exposure to cold gas or liquid. To minimize the risk of hazardous contact of cold gaseous nitrogen with any part of the body, wear personal safety equipment recommended for use with cryogenic materials including face shield, full-sleeved lab coat, and clean, dry gloves which fit loosely so they can be thrown off quickly if frozen by contact with the gas.

- j. **Asphyxiation** – If a large amount of liquid nitrogen is spilled in a small, poorly ventilated room or equipment, death from suffocation can result. All diffusion pumps are typically cleaned with acetone or alcohol. Acetone, alcohol, and most other solvents are very volatile (unstable). During cleaning, the volatility of these cleaners may permit their gases to displace air and its life-supporting oxygen which could cause death or serious injury by asphyxiation. Always ensure that cleaning operations are performed in large, well-ventilated areas.

While still hot, the diffusion pump may also contain decomposed and/or overheated pump oils which can also be an asphyxiant.

- k. **Large, Heavy Weights** – Diffusion pumps larger than 10 inches in diameter require power-assisted equipment and the use of trained moving/installation personnel in order to avoid dropping, slipping, and/or overturning the pump thus severely injuring personnel. Check weight of equipment before lifting and do not stand under equipment being moved.

 **WARNING**

High voltages (up to 480 V) can kill. Always break the primary circuit to the power supply before starting to work on the heater and/or its wiring.

 **WARNING**

Diffusion pumps are typically cleaned with acetone, alcohol, or other solvents.

When heated, sprayed or exposed to high temperature equipment, these solvents become flammable and explosive, causing serious injury or death. **Do not use near a high-temperature source.** Ventilate working area with a blower and use in large, well-ventilated room. When heated or sprayed, solvents also becomes 4 to 5 times heavier than air and will flow down, settling in tanks, pits, and low areas, thus displacing air which can kill by asphyxiation. Use in a large, well-ventilated room. Use of a self-contained breathing apparatus may be necessary.

Acetone, alcohol, and other solvents are irritants, narcotics, depressants, and/or carcinogenics. Their inhalation and/or ingestion may produce serious effects. Prolonged or continued contact with the skin will result in absorption through the skin and moderate toxicity. Always ensure that cleaning operations are carried out in large, well-ventilated rooms, and wear eyeshields, gloves, and protective clothing.

 **WARNING**

Varian has no control over the types of gases passing through this pump. These are entirely under the control of the process user and/or the hardware systems integrator. Frequently, process gases are toxic, flammable, corrosive, explosive, or otherwise reactive. Since these gases can cause serious injury or death, it is very important to plumb the exhaust of the pump to the facility's hazardous gas exhaust system which incorporates appropriate filters, scrubbers, etc., to insure that the exhaust meets all air and water pollution control regulations.

 **WARNING**

Certain gases can become corrosive and toxic when trapped in oil. Always wear protective gloves when handling dirty pump oil, drain it into a closable container, and do not breathe the fumes of the oil. Always use fully self-contained breathing apparatus.

 **WARNING**

If hazardous gas, vapors, chemicals, or combustible mixtures are pumped, sufficient quantities may exist during operation. This pump may contain decomposed and/or overheated pump oils or poisonous and/or overheated pump oils or poisonous and/or corrosive process materials which are highly toxic and also can be an asphyxiant. Proper operation will not always ensure that all hazardous materials have been removed.

 **WARNING**

Hot oils can cause serious burns. Wear protective gloves and long sleeved, loose fitting, heat resistant garments when draining pump oil.

 **WARNING**

When lifting some Varian diffusion pumps, use power-assisted equipment and trained moving/installation personnel to avoid dropping, slipping, and/or overturning the pump and severely injuring personnel. Check weight of equipment before lifting and do not stand under equipment being moved.

 **CAUTION**

Alcohol, acetone, and other solvents degrade O-ring materials reducing their ability to hold a vacuum. Do not use acetone or other solvents on O-rings. If necessary to clean O-rings, wipe with lint-free, clean cloth, wash in detergent and water, or use a small amount of pump oil.

 **NOTE**

Always dispose of used or dirty oil properly and in compliance with all local, state, and federal environmental laws and regulations.

Table of Contents

Section	Page
Safety Considerations	i
Section I – Specifications and Installation	1-1
1-1 Specifications	1-1
1-2 Installation	1-3
Section II – Operation	2-1
2-1 Start-up Procedure	2-1
2-2 Shutdown Procedure	2-2
Section III – Maintenance and Service	3-1
3-1 General	3-1
3-2 Periodic Inspection	3-1
3-3 Cleaning	3-1
3-4 Cold Cap Removal/Installation	3-2
3-5 Jet Assembly Removal/Installation	3-2
3-6 Heater Replacement	3-4
3-7 Adding Pump Fluid	3-4
Section IV – Troubleshooting	4-1
4-1 Leakage	4-1
4-2 Outgassing	4-1
4-3 Poor Pump or System Performance	4-1
Section V – Replacement Parts	5-1
5-1 Replacement Parts	5-1

List of Illustrations

Figure	Title	Page
3-1	Jet Assembly, VHS-10 and VHS-400 Pumps	3-3
3-2	Heater Connections, VHS-10 and VHS-400 Pumps	3-5
5-1	Wiring Diagram, VHS-400 Diffusion Pump	5-3
5-2	VHS-10 and VHS-400 Dimension Diagram	5-4
5-3	VHS-10 Pump Performance Curves	5-5
5-4	VHS-400 Pump Performance Curves	5-5
5-5	Fill and Drain Assemblies	5-6

List of Tables

Table	Title	Page
1-1	VHS-10 Pump Specifications	1-1
1-2	VHS-400 Pump Specifications	1-2
4-1	Troubleshooting	4-2
5-1	Replacement Parts	5-1

SECTION I

SPECIFICATIONS AND INSTALLATION

Before unpacking and installing the VHS-10 or the VHS-400 Diffusion Pumps, the user should thoroughly familiarize himself with this instruction manual and the diffusion pump specifications (see Table 1). He should also examine all other technical material supplied in order to gain a better understanding of the operating principles, limitations, correct application, and the hazards involved with the use of this equipment.

1-1 SPECIFICATIONS

Table 1-1 lists the specifications for the VHS-10 pump; Table 1-2 lists the specifications for the VHS-400 pump.

<i>Table 1-1. VHS-10 Pump Specifications</i>		
Power Rating	4400 watts	5100 watts
Optimum Operating Range (Torr)	1×10^{-3} to $<5 \times 10^{-9}$ (.133 to $< .000000655$ Pa)	1.5×10^{-3} to $<5 \times 10^{-9}$ (.1995 to $< .000000655$ Pa)
Maximum Pumping Speed (liters/sec – air)	5300 with std cold cap 4200 with extended cold cap	5300 with std cold cap 4200 with extended cold cap
(liters/sec – helium)	6600 with std cold cap 5200 with extended cold cap	6600 with std cold cap 5200 with extended cold cap
Maximum Throughput (Torr liters/sec at 0.01 Torr) (13.3 Pa)	7.0	8.1
Maximum Forepressure	No Load: 0.65 Torr (86.45 Pa) Full Load: 0.55 Torr (73.15 Pa)	
Backstreaming Rate at Pump Inlet	5.0×10^{-4} mg/cm ² /minute (with std cold cap) 1.0×10^{-4} mg/cm ² /minute (with extended cold cap)	
Electrical Requirements:	208, 240, 380, 480V, 50/60 Hz, 3-phase	
Warmup Time	12 minutes	
Cooldown Time (using quick cool) coil	22 minutes	25 minutes
(without quick cool coil)	65 minutes	67 minutes
Fluid Charge	1000 cc	
Cooling Water Requirements (max. inlet temperature)	60/80 degrees F	
(max. outlet temperature at foreline)	120 degrees F	
(general flow rate)	0.4 gpm	
Pressure drop across coils	5 psi	
Backing Pump Size Recommended	30 cfm for maximum throughput	
Jet Assembly	4-stage, self-aligning, aluminum	

Specifications and Installation

Table 1-1. VHS-10 Pump Specifications (Cont'd)

Foreline Baffle	Stacked, self-aligning half moon						
Cold Cap	Nickel-plated Copper						
Water Connections	1/8 FPT						
Thermal Switches	Manual reset at 300°F						
Heater circuit resistance (ohms)	4400 watts			5100 watts			
	L1-L2	L2-L3	L1-L3	L1-L2	L2-L3	L1-L3	
	208V	19.6	19.6	39.2	17	17	34
	240V	26.2	26.2	52.4	22.6	22.6	45.1
	380V	65.6	65.6	131.2	56.6	56.6	113.2
480V	104.7	104.7	209.4	90.4	90.4	180.8	
Clearance (for heater removal)	6 inches minimum						
Materials	Body, flanges, foreline baffle – Stainless Steel Jet Assembly – Aluminum Body Cooling Coils – Copper Quick Cooling Coil – Stainless Steel Cold cap – Nickel-plated copper						
Shipping Weight	150 pounds						

Table 1-2. VHS-400 Pump Specifications

Power Rating	4400 watts
Optimum Operating Range	1 x 10 ⁻³ to <5 x 10 ⁻⁹ (Torr) (.133 to < .000000655 Pa)
Maximum Pumping Speed (liters/sec – air)	8000 with std cold cap
Maximum Throughput (Torr liters/sec at 0.01 Torr) (13.3 Pa)	8.0
Maximum Forepressure (at 5 Torr liters/sec) (665 Pa)	No Load – 0.65 Torr (86.45 Pa) Full Load – 0.55 Torr (73.15 Pa)
Backstreaming Rate at Pump Inlet	< 0.001 mg/cm ² /minute (with std cold cap)
Electrical Requirements	208, 240, 380, 480V, 50/60 Hz, 3-phase
Warmup Time	17 minutes
Cooldown Time(using quick cool) coil (without quick cool coil)	22 minutes 65 minutes
Fluid Charge	1000 cc
Cooling Water Requirements	
(max. inlet temperature)	60/80 degrees F
(max. outlet temperature at foreline)	120 degrees F
(general flow rate)	0.4 gpm

Specifications and Installation

Table 1-2. VHS-400 Pump Specifications (Cont'd)

Pressure drop across coils	6 psi		
Backing Pump Size Recommended	30 cfm for maximum throughput		
Jet Assembly	4-stage, self-aligning, aluminum		
Foreline Baffle	Stacked, self-aligning half moon		
Cold Cap	Nickel-plated Copper		
Water Connections	1/8 FPT		
Thermal Switches	Manual reset at 300°F		
Heater circuit resistance (ohms)	4400 watts		
	L1-L2	L2-L3	L1-L3
208V	19.6	19.6	39.2
240V	26.2	26.2	52.4
380V	65.6	65.6	131.2
480V	104.7	104.7	209.4
Clearance (for heater removal)	6 inches minimum		
Materials	Body – Stainless steel Flanges, foreline baffle – Mild steel Jet Assembly – Aluminum Body Cooling Coils – Copper Quick Cooling Coil – Stainless steel Cold cap – Nickel-plated copper		
Shipping Weight	180 pounds		

1-2 INSTALLATION

1-2-1 Unpacking

- a Inspect the pump to ensure that no damage has occurred during shipping. Do not discard any evidence of rough handling; any damage should be reported to the carrier and to Varian without delay.
- b Diffusion pumps are factory-packed to permit prolonged storage in suitably protected areas without special precautions.
- c Remove flange covers and protective plugs from water connections. Be careful not to scratch the O-ring seal surface on the inlet and foreline flanges.
- d Inspect the internal jet assembly. It should be concentric and firmly seated on the bottom of the diffusion pump. Using a flashlight, check to ensure that the ejector nozzle is directly in line with the foreline. The location of the jet is controlled by an indexing pin located on the bottom of the pump.
- e The pump requires no initial cleaning if the required vacuum level is above 10^{-6} Torr (.000133 Pa). For pressure below 10^{-6} Torr (.000133 Pa), follow the cleaning procedure in the Maintenance section. Then charge the pump with the diffusion pump oil shipped with the pump.

1-2-2 Pump Oil Installation

- a The recommended oil charge for the VHS-10 and the VHS-400 diffusion pumps is 1000 cc.
- b The oil is normally poured into the pump inlet or the foreline or by removing the fill plug and pouring it into the fill and drain assembly.

1-2-3 Vacuum System Connections

 **WARNING**

Utility failure can cause damage to the equipment, overheating, and explosions. Designers of the equipment using diffusion pumps must take appropriate system design action to protect personnel and property from possible hazards. **Read the safety section at the beginning of this manual.**

- a The diffusion pump must be installed with the body vertical and plumb. Check to ensure that the pump inlet mating flange on the system is horizontal within \pm one degree. The boiler plate must be horizontal to prevent uneven fluid level. Failure to meet this requirement could result in overheating of the diffusion pump boiler plate.
- b Prepare the inlet and foreline O-rings by wiping them with a clean, lint-free cloth. A small amount of diffusion pump oil may be used to clean the O-rings.
- c Install the O-rings in the O-ring grooves. Be careful not to damage or scratch the sealing surface.
- d Check the fill plug for tightness. Apply light to medium torque, enough to compress the O-rings.
- e Using the appropriate lifting apparatus, align the bolt holes of the inlet flange with the bolt holes of the mating flange. Using the appropriate mounting hardware, tighten the bolts evenly until the O-ring is compressed and the flanges make light, metal-to-metal contact.
- f To ensure the integrity of the vacuum connections, they should be checked for leaks using a helium mass spectrometer leak detector before operating the vacuum system.

1-2-4 Cooling Water Connections

- a The inlet water fitting (near the inlet flange at the top of the pump) should be connected to a continuously running water supply at 0.4 gpm and at a temperature of 60 to 80°F.

 **NOTE**

In the following step, discharge connections must be installed in accordance with all Federal, State, and local laws and regulations.

- b The exit water temperature should not exceed 120°F.
- c The outlet or discharge (nearest the foreline) should be connected to an open drain.
- d If the diffusion pump is being cooled by a recirculating water system, the system must be capable of adequate cooling and heat exchange to ensure a continuous inlet temperature of 60 to 80°F. The recirculating system must also be capable of maintaining an adequate flow rate to ensure that exit water temperature does not exceed 120°F. The minimum rating of this system should be 85 percent of the maximum power rating of the diffusion pump.
- e The quick cool coil feed line, located at the boiler plate, should be controlled by a separate three-way valve (open, closed, and vent to atmosphere).
- f The quick cool drain must be connected to an open drain which is below the inlet connection of the quick cool coil. This will ensure that the quick cool coil is completely drained when the cooling water supply is turned off and the pump is vented to atmosphere.

1-2-5 Electrical Connections

⚠ WARNING

Diffusion pump heaters operate at voltages high enough to kill through electrical shock. During installation, check the drawings and be sure to attach all hazard warnings and cautions. Always break the primary circuit of the power supply when direct access to the heater or wiring is required. **Read the safety section in the front of this manual.**

- a The diffusion pump has been designed to operate at a specific voltage. The voltage is specified on the label that is mounted on the side of the pump. Verify the heater rating by measuring the resistance of the heater circuit (line-to-line) and comparing it to the values in Tables 1-1 and 1-2, Specifications.
- b Make the electrical connections in the junction box located near the foreline. The electrical supply should not be more than 5 percent above the rated voltage.
- c All electrical connections should be made in accordance with all applicable State, local, and/or industrial codes.

1-2-6 Thermal Switch

- a The pump has been fitted with a manually-resettable thermal switch that is preset at the factory. This switch is located in a box near the bottom of the pump and provides protection to the pump in the event of excessive fluid loss, the loss of cooling water, or high inlet pressure.

⚠ WARNING

Failure to properly connect the thermal switch circuit in the following step could result in catastrophic damage to personnel, the pump, or the vacuum system.

Specifications and Installation

- b Connect the leads of the thermal switch in series with the coil of the heater power supply. In the event of overtemperature, the thermal switch will open and shut off the power to the pump.
- c The thermal switch may be reset by pressing the button located at the center of the thermal switch. This should be done only after the root cause of a problem has been determined and the appropriate corrective action taken.

SECTION II

OPERATION



CAUTION

Damage to Pump

Do not turn on the heater without fluid in the pump. This may ruin the heaters and damage the pump.

Damage to Pump Fluid

- Do not air-release the pump while the boiler is hot. Most diffusion pump fluids are heat-sensitive and will break down under these conditions.
- Do not operate the pump without the internal splash baffle or foreline baffle in place. If the splash baffle is omitted, the pump may be unstable and operate at low speed. If the foreline baffle is omitted, there may be more than usual fluid loss.
- Do not operate the pump for extended periods at inlet pressures above 1 micron (.133 Pa). High-pressure operation may cause excessive backstreaming.
- Do not operate the pump heater unless the cooling water is circulating. It will cause the pump and fluid to overheat.

2-1 STARTUP PROCEDURE

- a During initial operation of the diffusion pump, a fresh charge of diffusion pump oil may go through a degassing process. This may result in inlet and foreline pressure fluctuations. These pressure fluctuations are normal.
- b Visually inspect the sight glass assembly to ensure that the diffusion pump has been charged with the proper amount of diffusion pump fluid. When properly filled, the oil level (when the pump is cold) will be even with the FULL/COLD mark on the oil level indicator.
- c Evacuate (rough pump) the diffusion pump with a mechanical backing pump (customer-supplied). The pressure must be reduced to less than 0.5 Torr (66.5 Pa). The backing pump should remain connected to the foreline of the diffusion pump.
- d Turn on the cooling water supply to the pump body. Check that the cooling water is not being supplied to the quick cool coil at this time.
- e Turn on the power to the diffusion pump heater.
- f Monitor inlet and foreline pressures.
- g During operation of the diffusion pump, the gas load at the inlet should not exceed the maximum throughput capability of the pump. The forepressure should not exceed the specified tolerable forepressure.

2-2 SHUTDOWN PROCEDURE

- a Turn off the power to the diffusion pump. Continue to back the diffusion pump with the appropriate mechanical pump.
- b Allow cooling water to flow through the diffusion pump until the pump body temperature, located just above the boiler plate, has cooled to a temperature of 130°F.
- c After isolating the backing pump, the diffusion pump may be vented to atmosphere.
- d If faster cooling is desired, the pump can be cooled using the quick cool coil at the bottom of the diffusion pump. Follow the instructions in para. 1-3-3 for proper setup of the quick cool coil line. The same procedure for shutdown can be followed.

SECTION III

MAINTENANCE AND SERVICE

3-1 GENERAL

Diffusion pumps generally require little attention when operated correctly. It is advisable to perform some periodic inspections to ensure trouble-free operation. By performing simple preventive maintenance, costly downtime can be avoided. A day-to-day log of pump and system performance will help indicate the condition of the pump and the need for corrective action.

3-2 PERIODIC INSPECTION

The frequency of inspection will depend on the type of system, its operation, and use. The maximum interval between inspections is established on the basis of experience. It is recommended that the following items be regularly examined:

- a When the pump is cold, check the condition and level of the fluid. These can be inspected by withdrawing a fluid sample through the drain and by visually checking the level of the fluid through the sight glass. A slight discoloration of the fluid does not affect performance. **Always use new o-rings when replacing fill plugs or the sight glass.**
- b Loss of fluid can be caused by the following:
 - 1 Incorrect venting procedures and/or admittance of excessive air or other gas to a hot pump.
 - 2 Inadequate water cooling.
 - 3 Prolonged operation at inlet pressures above 10^{-3} Torr (.133 Pa).
 - 4 Failure to reinsert the foreline baffle in the pump assembly.
- c Check the total heater power input.
- d When the pump is cold **and the power is off**, check to ensure that the heaters are bolted snugly to the boiler plate. Also check all heater terminal connections at the heater and inside the junction box and make certain that they are tight and in good condition.
- e Check to ensure that cooling water flow is adequate and unobstructed. In areas where the mineral content of the water is high or where there is considerable sediment, it may be advisable to install water filters.

3-3 CLEANING

Complete cleaning of the pump may be periodically required because of the gradual deterioration of some pump fluids. Removal of the pump from the system is then necessary.

- a Turn off the power and disconnect the power supply plug.
- b After the pump has cooled, turn off the cooling water and disconnect the cooling lines.
- c Unbolt the inlet flange and foreline connections. Remove the pump from the system.
- d Drain the diffusion pump of all fluid.
- e Remove all O-rings, the cold cap assembly, the jet assembly, and the foreline baffle from the pump.

- f Thoroughly clean the diffusion pump body interior and the jet assembly using acetone followed by an isopropyl alcohol rinse. Dry the pump and the jet assembly with clean, dry, oil-free compressed air.
- g Install the foreline baffle, the jet assembly, and the cold cap assembly in the pump body. Check that the ejector nozzle is properly aligned with the foreline. Also check that the cold cap is properly installed on the jet assembly. The space between the underside of the cold cap and the outside of the jet cap should be uniform.
- h Reinstall the diffusion pump in the system using all new O-rings.
- i Charge the pump with the proper amount of fluid (1000 cc).
- j Reconnect the water cooling lines and the power supply.
- k Evacuate the diffusion pump with the appropriate mechanical pump.
- l Turn on the cooling water.
- m After the pump has been evacuated to a pressure below 0.5 Torr (66.5 Pa), turn on the power to the diffusion pump.

3-4 COLD CAP REMOVAL/INSTALLATION

To remove the cold cap, proceed as follows.

- a Remove the screw that secures the cold cap to the jet assembly.
- b Loosen the bolt that secures the cold cap to the side of the pump.
- c Lift out the cold cap.

To install the cold cap, proceed as follows.

- a Place the cold cap on top of the jet assembly with the mounting bracket straddling the copper bar located on the inside wall of the pump and tighten it lightly.
- b Center and level the cold cap over the jet assembly then install the screw that holds the cold cap to the jet assembly.
- c Tighten the bolt that secures the cold cap to the pump body.

3-5 JET ASSEMBLY REMOVAL/INSTALLATION

To remove the jet assembly, proceed as follows.

- a Remove the cold cap from the pump.
- b Unscrew the cold cap from the jet assembly.
- c Lift out each section of the jet assembly. Do not dent or otherwise damage the jet assembly during disassembly or cleaning.
- d Remove the splash baffle from the pump.

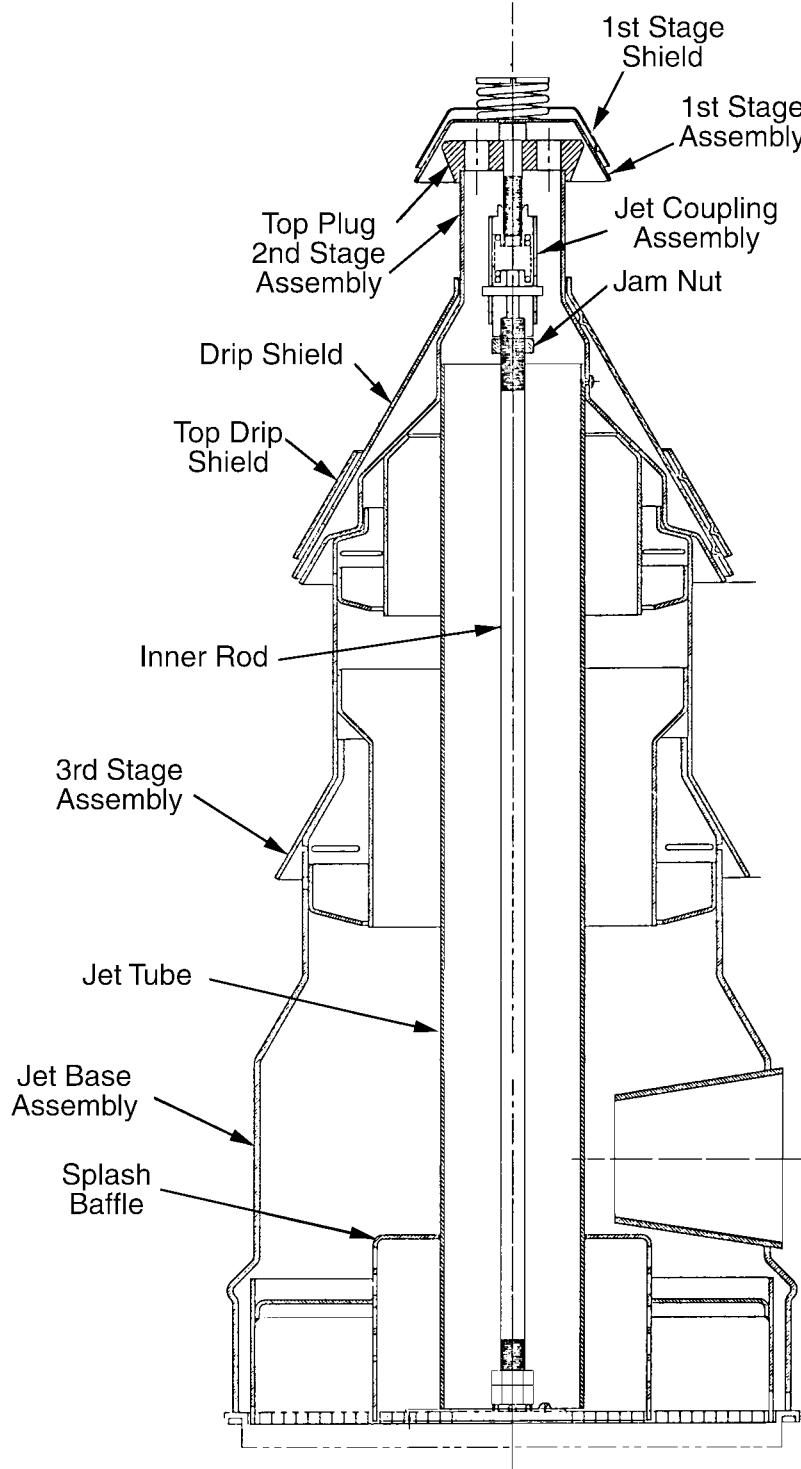

Figure 3-1 Jet Assembly, VHS-10 and VHS-400 Pumps

To install the jet assembly, proceed as follows.

- a Place the splash baffle in the bottom of the pump. Check that it is located in the outer boiler groove.
- b Insert the jet base, making sure the ejector is aligned with the foreline, followed by the remaining stages of the jet. Make sure that all stages are firmly seated and that all drip shields are in place.
- c Install the cold cap assembly.

3-6 HEATER REPLACEMENT

- a Turn off the power to the diffusion pump and disconnect the power supply.
- b Remove the heater cover and the insulation from the bottom of the diffusion pump.
- c Label the heater wires for proper location during installation.
- d Disconnect the terminal leads. **Use two wrenches when loosening these nuts to prevent breaking the heater terminals.**
- e Remove the nuts holding the heater clamp. **The heater clamp is fairly heavy (eight pounds); use caution when removing it.**
- f Lower the entire heater unit from the pump.
- g Replace the defective heater.
- h Install a new heater crush plate.
- i Assemble the heater, crush plate (with dimples facing the heater element), and clamping plate as a unit.
- k Coat the boiler studs with an antiseize compound such as FEL-PRO C5A or common milk of magnesia.
- l Support the heater unit by the clamping plate, line up the holes with the boiler studs, and push the unit up against the boiler plate. Use two nuts, tightened finger-tight, to hold it in place.
- m Secure the remainder of the nuts finger-tight, then tighten the bolts evenly to a torque of 250 inch-pounds.
- o Replace the heater insulation and the cover.

3-7 ADDING PUMP FLUID

The recommended fluid charge for the VHS-10 and the VHS-400 diffusion pumps is 1000 cc. The fluid charge will gradually be depleted through use, but the pump will continue to operate normally. When the charge is reduced to approximately 60 percent of the initial fill amount, the boiler plate temperature may begin to rise. Under this condition, the thermal switch, when properly connected, is designed to open the heater circuit.

- a Turn off the power to the pump.
- b Allow the pump to cool until the temperature of the pump body, measured one inch above the heater skirt, has cooled to 130 degrees F.
- c Vent the pump to atmosphere.

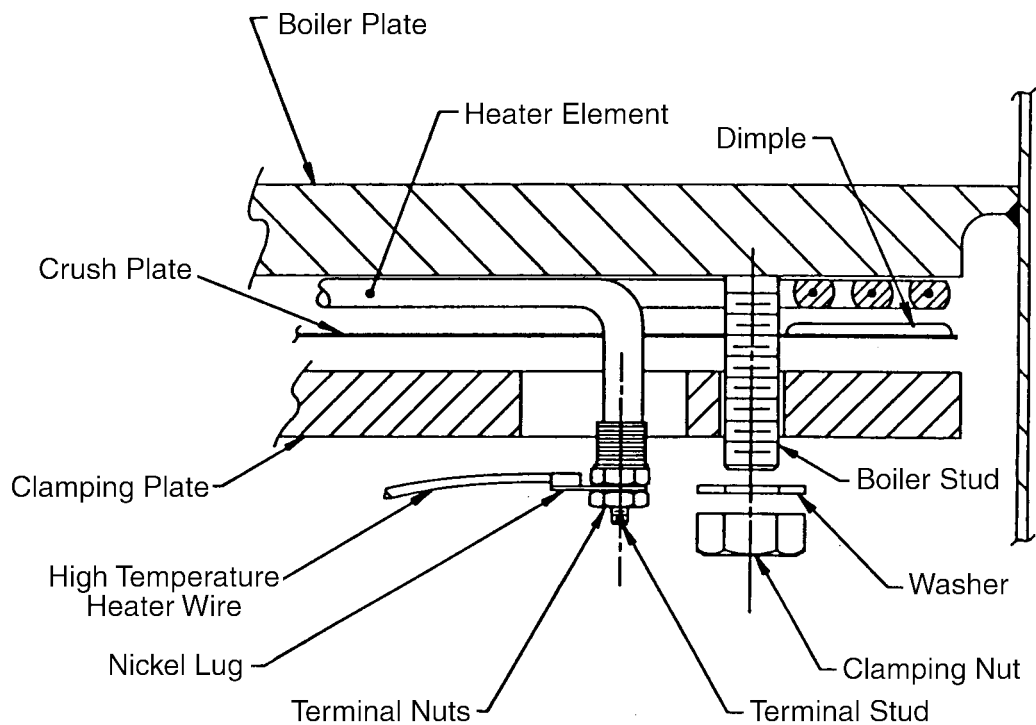

Figure 3-2 Heater Connections, VHS-10 and VHS-400 Pumps

- d Loosen and remove the fill plug located at the top of the sight glass assembly.
- e Add pump fluid until the fluid level is even with the FULL/COLD mark on the oil level indicator.
- f Replace the O-ring in the fill plug and lubricate it with pump fluid.
- g Install the fill plug and tighten it moderately.
- h Evacuate the diffusion pump and start it following the procedures outlined in previous sections.

SECTION IV

TROUBLESHOOTING

4-1 LEAKAGE

Analysis of general operational experience with diffusion pumps indicates that certain locations are more prone to vacuum leaks. The following locations should be checked first if leakage is the suspected cause of poor system performance.

- 1 Inlet and foreline connections
- 2 Drain and fill plugs
- 3 Other compression fittings, such as high-vacuum gauges in the system
- 4 Threaded connections, such as foreline gauge

4-2 OUTGASSING

High-vacuum systems, even without external leakage, can also exhibit high gas loads due to outgassing from internal surfaces or processes. The pressure in the system is a result of gas load divided by pumping speed ($P = Q/S$). If the gas load (Q) exceeds the maximum throughput capability of the diffusion pump, the diffusion pump will not function and the pumping action will essentially be performed by the mechanical backing pump.

To estimate the gas load, isolate the system from all pumps after evacuation and measure the rate of pressure rise. The gas load created by the system can be estimated as:

$$Q = \frac{V \times \Delta P}{\Delta t}$$

where: V is the isolated volume, ΔP is the pressure rise, and Δt is the time period of measurement.

4-3 POOR PUMP OR SYSTEM PERFORMANCE

Before proceeding with a step-by-step troubleshooting program, check the performance and accuracy of the vacuum gauges used on the system. Table 2 shows the most frequent faults, their probable causes, and specific repair actions required for each.

Troubleshooting

Table 4-1 Troubleshooting

Fault	Probable Cause	Corrective Action
Poor system pressure	Leaks in system, virtual or real	Locate and repair.
	High process gas load	Measure gas load, eliminate cause.
	System dirty	Clean system to reduce outgassing.
Poor ultimate pressure	Contaminated pump fluid	Examine and replace.
	Low heat input	Check voltage. Check for continuity, burned-out element, poor thermal contact.
	Inadequate cooling water flow	Check water pressure. Check tubing for obstructions and backpressure.
	Excessive or too cold cooling water	Check temperature. Adjust flow.
	High forepressure	Check for leak in foreline, poor mechanical pump performance, breakdown of mechanical pump fluid.
	Water in quick-cool coil	Check and remove cause.
Slow pumpdown (Prolonged cycle after checking gas load conditions)	Low heat input	Check heaters.
	Low oil level	Add oil.
	Malfunctioning pump assembly.	Check and repair or replace.
	Improperly located jets. Damaged jet system.	
Inlet pressure surges	Incorrect heater voltage	Check and correct voltage.
	Fluid outgassing	Condition fluid by operating the pump for a few hours.
	Leak in system ahead of pump inlet	Check and correct.
High chamber contamination	Forepressure too high	Check for leak in foreline, poor mechanical pump performance, breakdown of pump fluid, and incorrect valve operation.
	Prolonged operation at high throughput at pressure above 10^{-3} Torr (.133 Pa)	Review operating procedures.
	Improper system operation and air release procedures	Review operating procedures.
Pump will not start	Safety circuits and/or protective devices prevent contactor from staying closed	Check utilities, flow switches, interlocks. Check thermostat operation.

SECTION V

REPLACEMENT PARTS

The following is a list of replacement parts for the Varian VHS 10 and VHS 400 Diffusion Pumps.

Table 5-1 Replacement Parts

Part Number	Description
F0429301	Standard Cold Cap Assembly, VHS-10 only
K4823301	Standard Cold Cap Assembly, VHS-400 only
L8917301	Extended Cold Cap Assembly, VHS-10 only
L8908301	Sight Glass Repair Kit, consisting of:
L8816001	Sight Glass
L9694001	Gasket, Teflon
Coml	O-ring, Viton, Parker No. 2-113
Coml	O-ring, Viton, Parker No. 2-226
F0428301	Jet Assembly
L6367301	Jet Coupling
F0431301	Splash Bottle
F0435301	Foreline Baffle Assembly
L8912301	Thermoswitch Kit, Consisting of:
642906025	Switch
648056680	Lug
656179100	Wire
89867001	Box, Insulator
L8913301	Heater Wiring Kit, Consisting of:
648056680	Lug
648091065	Terminal Strip
656179100	Wire
64731040	208V/2200 watt Heater Element, 2 required
64731040	208V/2200 watt Heater Element, 2 required
647310160	380V/2200 watt Heater Element, 2 required
647310170	480V/2200 watt Heater Element, 2 required
647310145	208V/2550 watt Heater Element, 2 required
647310155	240V/2550 watt Heater Element, 2 required
647310165	380V/2550 watt Heater Element, 2 required
647310175	480V/2550 watt Heater Element, 2 required
K7667001	Heater Crush Plate (required with heater replacement)
K4928001	Heater Clamping Plate
L8914001	Heater Insulating Blanket
K0377169	O-ring kit; includes:
(VHS-10 only)	1 butyl inlet flange O-ring (F0430001)
	1 Buna-N foreline O-ring, Parker No. 2-338
	10 Viton fill and drain O-rings (old style fill and drain assy), Parker No. 2-112
	10 Viton fill and drain O-rings (new style fill and drain assy), Parker No. 2-113
	1 Sight glass O-ring, Parker No. 2-035
	1 Sight glass O-ring, Parker No. 2-226

Replacement Parts

Table 5-1 Replacement Parts (Cont'd)

Part Number	Description
K0377169 (VHS-400 only)	O-ring kit; includes: 1 Butyl inlet O-ring, Parker No. 2-385 1 Buna-N foreline O-ring, Parker No. 2-338 10 Viton fill and drain O-rings (old style fill and drain assy), Parker No. 2-112 10 Viton fill and drain O-rings (new style fill and drain assy), Parker No. 2-113 1 Sight glass O-ring, Parker No. 2-035 1 Sight glass O-ring, Parker No. 2-226
695474005	DC-704 Diffusion Pump Fluid (500 cc container) 2 required, or
695475005	DC-705 Diffusion Pump Fluid (500 cc container) 2 required

Replacement Parts

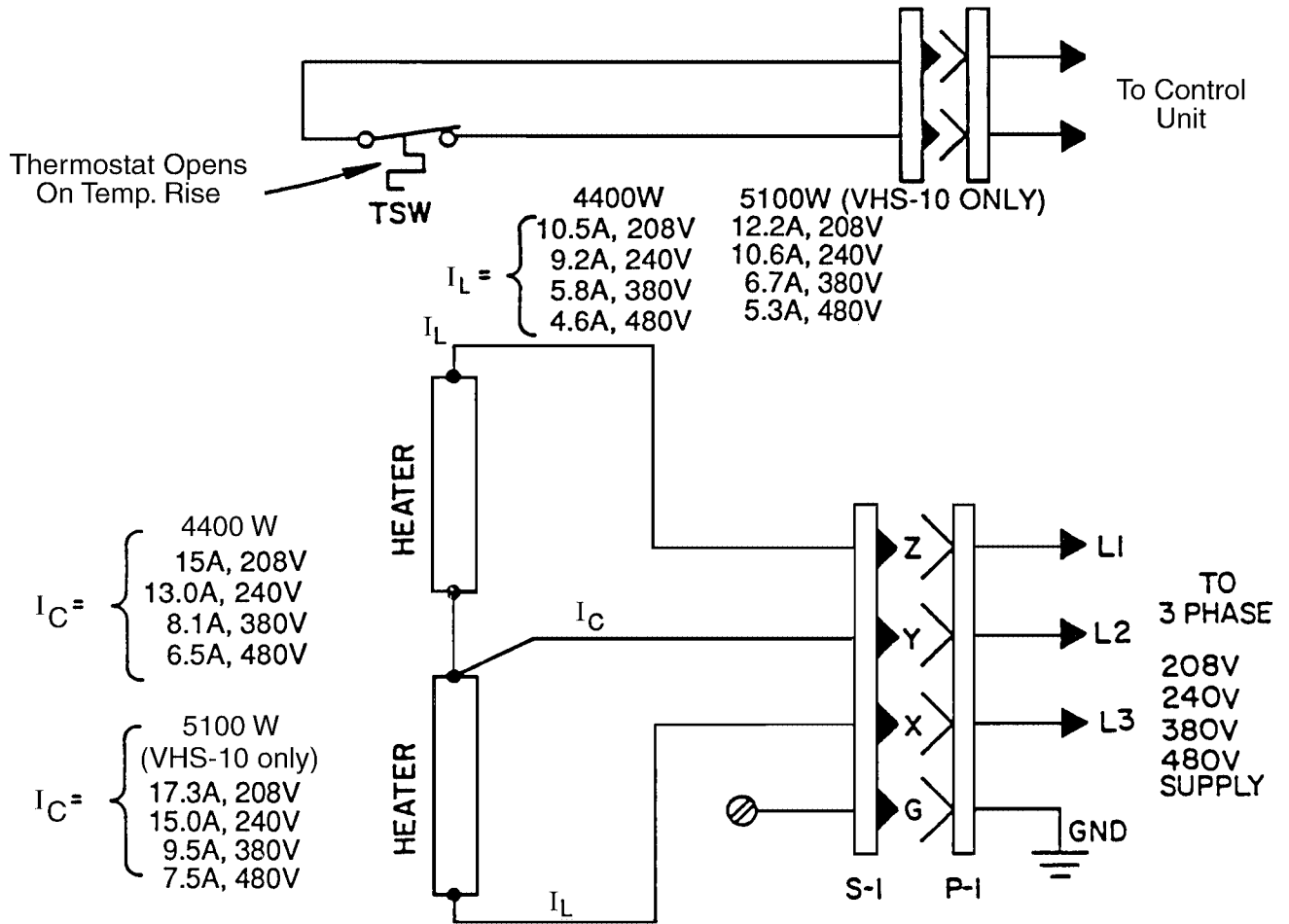

Element Resistance

Voltage	4400 W	5100 W (VHS-10 only)
208	19.6 Ω	17 Ω
240	26.2 Ω	22.6 Ω
380	65.6 Ω	56.6 Ω
480	104.7 Ω	90.4 Ω

Total Resistance

Voltage	4400 W			5100 W (VHS-10 only)		
	L1-L2	L2-L3	L3-L1	L1-L2	L2-L3	L3-L1
208	19.6	19.6	39.2	17.0	17.0	34.0
240	26.2	26.2	52.4	22.6	22.6	45.1
380	65.6	65.6	131.2	56.6	56.6	113.2
480	104.7	104.7	209.4	90.4	90.4	180.8

Figure 5-1 Wiring Diagram, VHS-400 Diffusion Pump

Replacement Parts

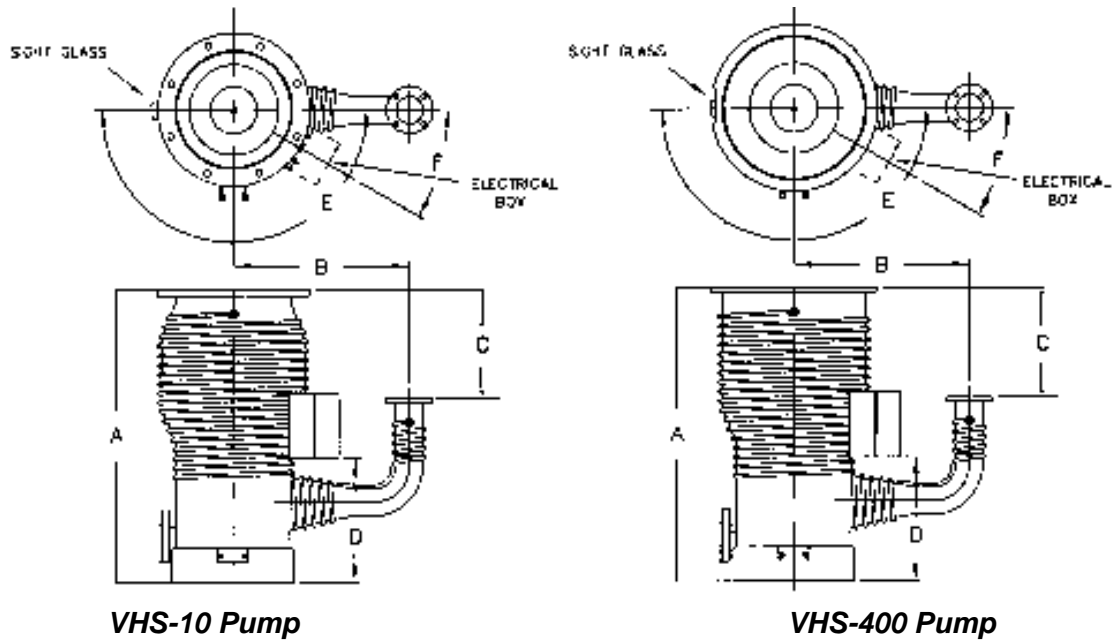

	VHS-10						VHS-400			
	ASA		ISO		ConFlat		ASA		ISO	
	in	mm	in	mm	in	mm	in	mm	in	mm
A Height	31.00	787	31.00	787	31.00	787	31.00	787	31.00	787
B Centerline to Centerline	18.56	471	18.56	471	18.56	471	18.56	471	18.56	471
C Flange Face to Flange Face	11.62	295	11.62	295	11.62	295	11.62	295	11.62	295
D Electrical Box Height	13.00	330	13.00	330	13.00	330	13.00	330	13.00	330
E Sight Glass, Degrees from Foreline	180°		180°		180°		180°		180°	
F Electrician Box, Degrees from Foreline	30° Clockwise		30° Clockwise		30° Clockwise		30° Clockwise		30° Clockwise	
Inlet Flange, Nominal Size	10" ASA		ISO-320-K		14" CFF		Special		ISO-400-K	
Inlet Flange, OD	16.00	406	14.57	370	14.00	356	18.00	457	17.72	450
Inlet Flange, ID	12.19	310	12.03	306	12.19	310	15.20	384	15.20	384
Inlet Flange, thickness	0.75	19	0.67	17	1.12	28	0.50	13	0.67	17
Inlet Flange, Bolt Circle	14.25	362	N/A	N/A	12.81	325	17.75	450	N/A	N/A
Inlet Flange, No. of holes	12		N/A		30		12		N/A	
Inlet Flange, Hole Size	0.94	24	N/A	N/A	0.39	10	0.32	8.1	N/A	N/A
O-ring Groove ID	12.50	318	N/A	N/A	N/A	N/A	16.00	406	N/A	N/A
O-ring Groove Width	0.24	6	N/A	N/A	N/A	N/A	0.25	6.3	N/A	N/A
Foreline Flange, Nom. Size	2" ASA		ISO-63-K		4 ⁵ / ₈ " CFF		2" ASA		ISO-63-K	
OD	6.00	152	3.74	95	4.62	117	6.00	152	3.74	94
ID	2.91	74	2.93	74	2.91	74	2.91	74	2.91	74
Thickness	0.50	13	0.47	12	0.81	21	0.50	13	0.47	12
Bolt Circle	4.75	121	N/A	N/A	4.03	102	4.75	121	N/A	N/A
Number of Holes	4		N/A		10		4		N/A	
Hole Size	0.75	19	N/A	N/A	0.33	8	0.75	19	N/A	N/A
O-ring Groove ID	3.06	78	N/A	N/A	N/A	N/A	3.06	78	N/A	N/A
O-ring Groove Width	0.30	8	N/A	N/A	N/A	N/A	0.30	8	N/A	N/A

Figure 5-2 VHS-10 and VHS-400 Dimension Diagram

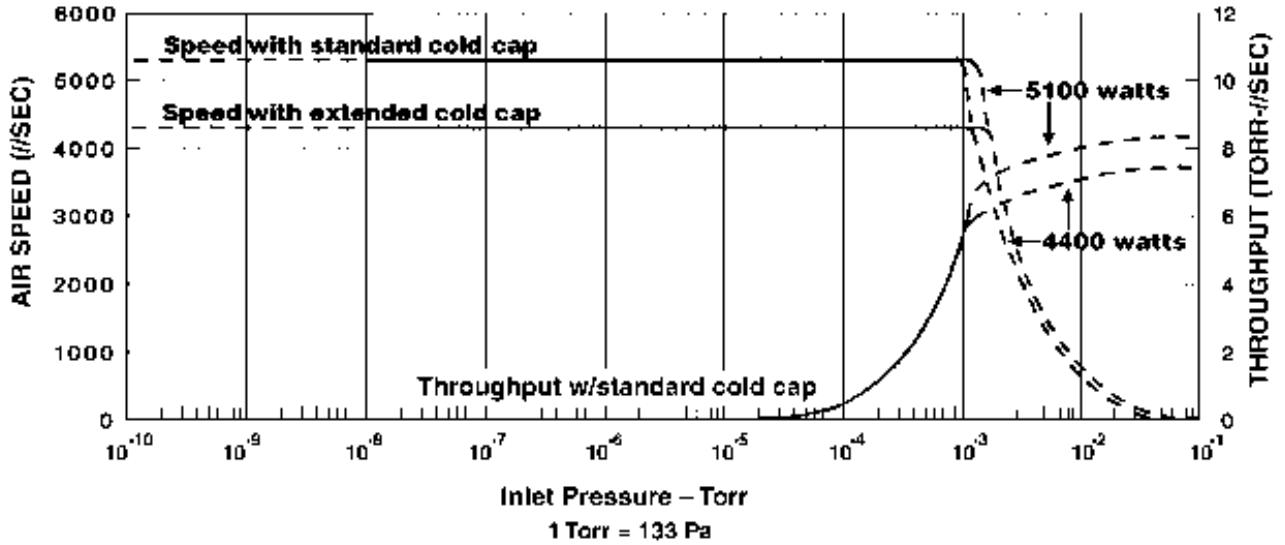

Figure 5-3 VHS-10 Pump Performance Curves

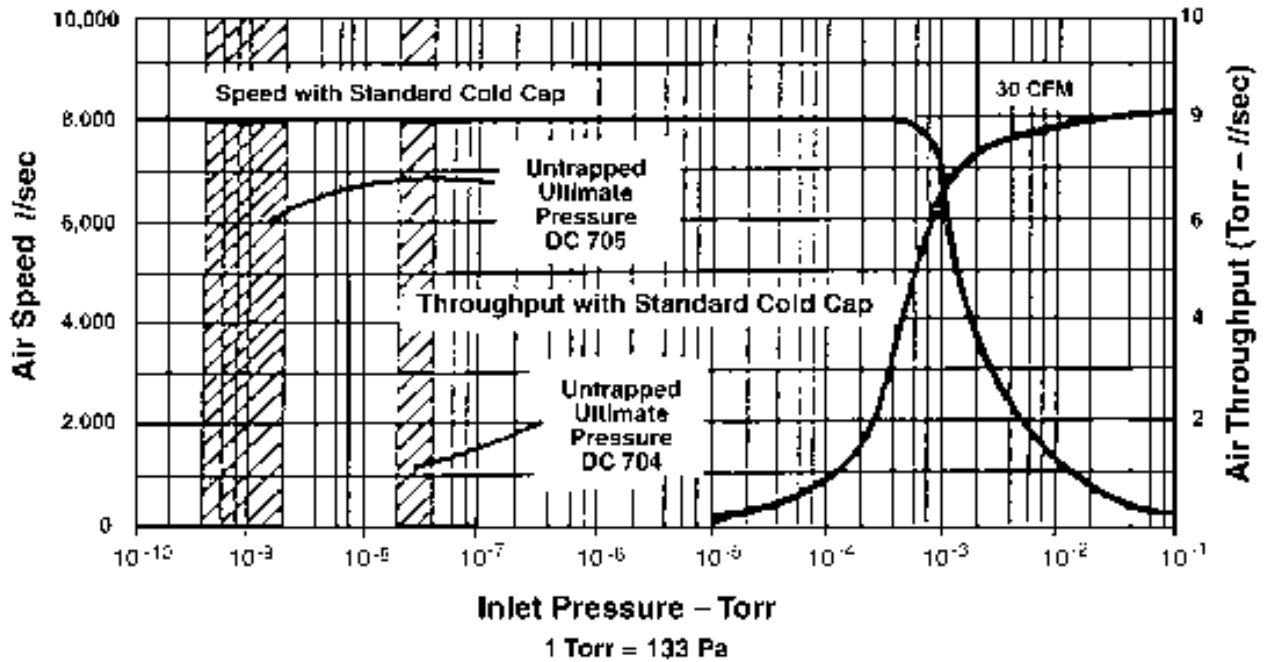
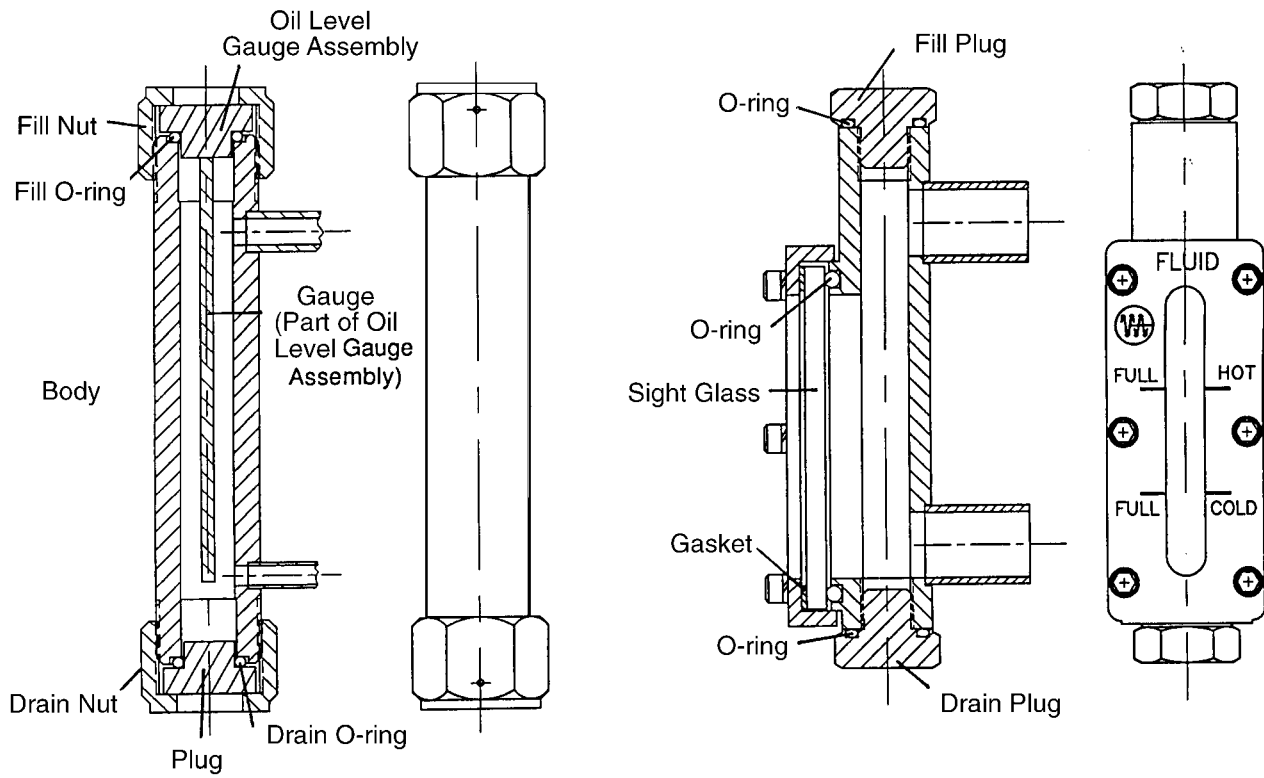

Figure 5-4 VHS-400 Pump Performance Curves

NOTE
 Speed curves were generated according to AVS Standard 4.1

Replacement Parts



Old Style – Typical

New Style – Typical

Figure 5-5 Fill and Drain Assemblies