

Technologie du vide
High vacuum technology
Hochvakuumtechnik



FOR SALES AND SERVICE PLEASE CALL:

PTB SALES T :: 626.334.0500
service@ptbsales.com
www.ptbsales.com

DATE SERVICED: _____

VIEW OUR INVENTORY

Notice technique
Instruction manual
Technische Beschreibung

POMPES PRIMAIRES MÉCANIQUES
MECHANICAL FOREPUMPS
MECANISCHE FEINVAKUUMPUMPEN

TYPE/TYP: 1004 A - 2004 A - 2008 A
1012 A - 2012 A - 2020 A

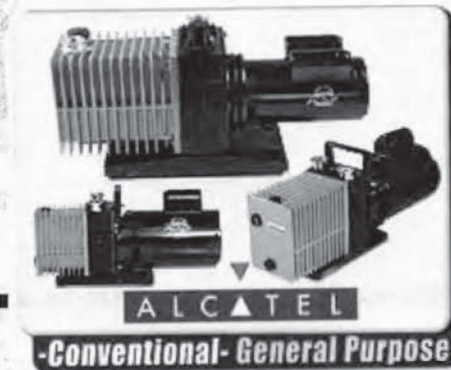

ALCATEL

MECHANICAL FOREPUMPS

TYPES 1004 A – 2004 A – 2008 A – 1012 A – 2012 A – 2020 A

CONTENTS

	Page		Page
NOTES	19	4.2 Operating of Gas Ballast	24
I. INTRODUCTION	20	4.2.1 Starting	24
1.1 Description of Product	20	4.2.2 Pumping Condensables	24
1.2 Electrical characteristics	20	4.3 High-Pressure Pumping	24
1.3 Dimensions	20	4.4 Changing from One Type of Oil to Another	25
1.4 Characteristics and Performance	20	4.5 Oil Level-Draining	25
		4.6 Flushing	25
II. OPERATING PRINCIPLE	21	V. DISASSEMBLY, CLEANING, AND REASSEMBLY	26
2.1 Single-Stage Vane Pump	21	5.1 disassembling Motor-Pump Assembly	26
2.2 Two-Stage Vane Pump	21	5.2 Disassembling Moving Parts	26
2.3 Oil	21	5.2.1 Disassembly of Two-Stage Pumps	26
2.4 Anti-Suckback System and Lubrication	21	5.2.2 Disassembling of Single-Stage Pumps	26
2.5 Gas Ballast	21	5.3 Cleaning Metal Parts	27
		5.4 Replacing Seals and Other Elastomer Parts	27
III. MOUNTING AND INSTALLATION	22	5.4.1 O-Rings	27
3.1 Unpacking	22	5.4.2 Shaft Seals	27
3.2 Storage	22	5.4.3 Flat Gasket	27
3.3 Choosing Correct Oil	22	5.5 Reassembly	27
3.3.1 Why Correct Oil is Important	22	5.6 Tools	27
3.3.2 Recommended Oils	22	VI. SPARE PARTS	28
3.3.3 Oxygen Pumping	23	6.1 Seal Kit	28
3.4 Setup	23	6.2 Maintenance Kit	28
3.4.1 Filling Pump with Oil	23	6.3 Anti-suckback system kit	28
3.4.2 Mechanical Connections	23	VII. TROUBLESHOOTING	29
3.4.3 Accessory Table	23	VIII. ACCESSORIES	30
3.4.4 Electrical Connection	23	8.1 Remote Controlled Gas Ballast	30
IV. OPERATION AND MAINTENANCE	24	8.2 Oil Mist Eliminator	31
4.1 Starting	24	8.3 Liquid Nitrogen trap NW 25	32
4.1.1 Temperature	24	8.4 Dust Filter NW 25	33
4.1.2 Starting	24	Dimensions	50
		Divers Diagrams	51 to 56
		Accessories	57 to 58
		Nomenclature and General Drawing	59 to 62

NOTES

APPLICATIONS AND LIMITATIONS

Alcatel vane pumps are designed to ensure complete safety for the worker and the workplace when used properly. It is the user's responsibility to follow the warnings, precautions, and maintenance requirements set forth in this manual.

IMPORTANT NOTE :

Alcatel Standard 1004 A - 2004 A - 2008 A - 1012 A - 2012 A - 2020 A, pumps are designed to pump neutral or slightly corrosive gases.

EQUIPMENT INSPECTION ON DELIVERY

The equipment has been thoroughly tested, checked, and carefully packed before leaving the plant.

Shipper assumes responsibility for delivery. No claims relating to condition of materials shipped will be accepted unless submitted within eight days of receipt of goods.

No returned materials will be accepted without prior authorization of Alcatel.

Before unpacking equipment, please see § 3.1. If the equipment must be stored, see § 3.2.

We reserve the right to cancel the warranty :

- **If the equipment is disassembled without authorization from Alcatel**
- **If spare parts not made by ALCATEL are used**
- **if corrosive gases are pumped.**

I INTRODUCTION

1.1 DESCRIPTION OF PRODUCT

ALCATEL oil-sealed mechanical pumps are used in every application of vacuum technology (laboratories, industry, etc.). They can only be used to obtain a medium vacuum (up to 10^{-3} mbar) or in pumping assemblies, for example to back a diffusion pump or turbomolecular pump.

Pumps in the 4, 8, 12 and 20 m³/h serie have the following features in common :

- direct transmission makes them highly compact and an incorporated handle makes them portable ;
- they are equipped with an antinoise system ;
- an antisuckback system ensures that the pump will retain its vacuum tightness when stopped ;
- a gas ballast allows condensable vapors to be pumped ;
- the inlet and exhaust connections are according to Pneurop standards and enable numerous accessories to be connected (see § 3.4.2) ;
- a sight glass on the oil case indicates the oil level ;
- the principal parts are provided with pins to facilitate disassembly, reassembly, and replacement of defective parts without affecting the specifications in the manual.

Pumps in the Standard series are designed to pump neutral or normal atmosphere gases. The pump takes accessories to adapt it to other applications.

1.2 ELECTRICAL CHARACTERISTICS

The pumps can be supplied with different types of motors (voltage, frequency, type of motor protection...).

Depending of the destination, the motors can perform differently, in accordance with the user's country.

The tables on diagram 05 "Electrical motors", indicate the characteristics of different standard motors.

Upon request, other types of motors can be delivered (special voltage, explosion proof...).

1.3 DIMENSIONS

See Diagram 01 at the back of this book.

1.4 CHARACTERISTICS AND PERFORMANCE

TECHNICAL DATA	Unit	1004 A		2004 A		2008 A		1012 A		2012 A		2020 A	
		50	60	50	60	50	60	50	60	50	60	50	60
Frequency	Hz												
Number of stages		1		2		2		1		2		2	
Nominal rotational speed	rpm	1500	1800	1500	1800	1500	1800	1500	1800	1500	1800	1500	1800
Free air displacement	m ³ /h	4.5	5.4	4.5	5.4	10	12	15	18	15.7	18	22.4	26.9
	cfm	3.2		3.2		7		11		11		15.9	
Air displacement Pneurop method	m ³ /h	3.7	4.5	4	4.8	7.5	9	11	13	12	15	18	21.6
	mbar	< 5.10 ⁻²		< 1.10 ⁻¹		< 1.10 ⁻¹		< 2.10 ⁻²		< 1.10 ⁻¹		< 1.10 ⁻¹	
Oil capacity	l	1.12		0.75		1		1.16		0.8		0.8	
Weight ** (with three-phase motor)	kg	15.5		18		19		19.5		20		26.7	
	kg	22		24.5		25.5		25		28.5		28.3	
Inlet and exhaust Pneurop flange		NW 25										NW 25***	

* Partial pressure measured by Pneurop method.
The above specifications are for pumps filled with ALCATEL 100 oil. They may vary if other oils are used (see § 3.3.2).

** Change with motor type.

*** Option : NW 40.

II. OPERATING PRINCIPLE

2.1 SINGLE-STAGE VANE PUMP

The functional part of a vane pump is composed of :

- a hollow cylindrical stator with an inlet and an exhaust valves;
- a rotor driven rotationally inside the stator (and off center with respect to it) to permit pumping ;
- two vanes sliding in the rotor, forced against the stator by centrifugal force and springs.

The pumping cycle is as follows :

- **intake :** As the vane passes in front of inlet orifice an increasing space is formed into which the gas from the chamber to be evacuated expands. When the second vane passes, the space is closed.
- **transfer :** The gas trapped in the space between the two vanes is transferred to the exhaust orifice as the rotor rotates.
- **compression :** The space communicates with the exhaust, which is fitted with a valve ; the gas is compressed until open the valve.
- **exhaust :** The gas is expelled into the oil casing when the pressure is sufficient to open the valve.

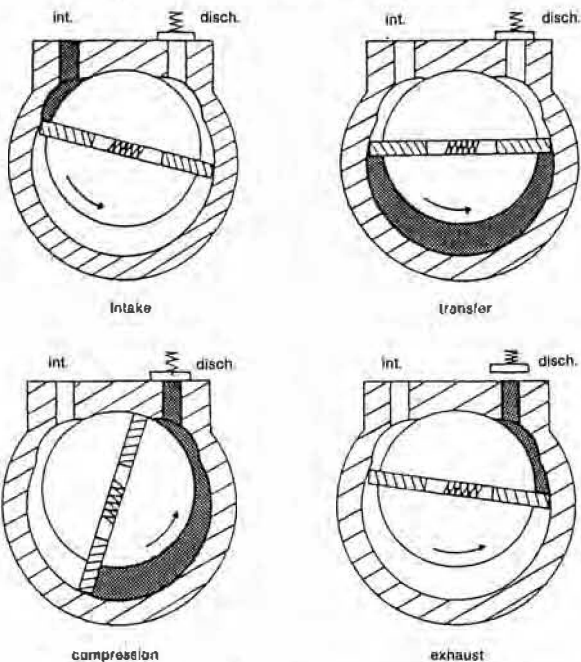

2.2 TWO-STAGE VANE PUMP

To improve the backing pressure and displacement at low pressure, two stages are connected in series. The second is similar to the first both structurally and operationally. The gases drawn in by first stage (LP low pressure), are transferred to second stage (HP high-pressure) and discharged through the high pressure discharge valve.

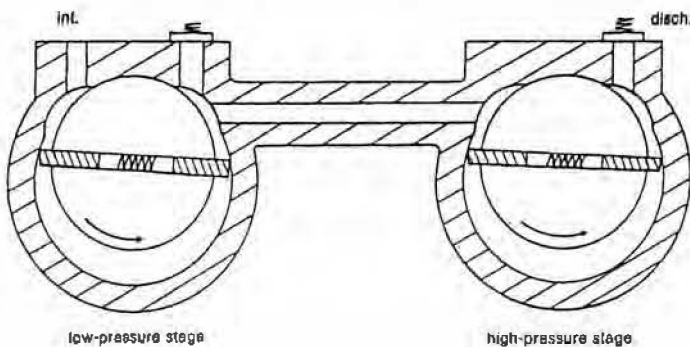

2.3 OIL

Oil has several important functions in the pump :

- It lubricates mechanical components (bearings, shaft seals, rotor, vanes, etc.) ;
 - It makes moving parts relatively tight by limiting internal leakage ;
 - It carries away the heat produced by the compressed gases.
- ALCATEL has selected various types of oil for its pump ; they are listed in § 3.3.2.

2.4 ANTI-SUCKBACK SYSTEM AND LUBRICATION

If the power supply should fail or the pump stops, an anti-suckback device prevents air or oil in the pump for being drawn back into the chamber being evacuated :

- by flush-mounted O-rings between the surfaces of the functional elements (stators, flanges, frame, etc.) ;
- by spring-loaded check valves placed in the exhaust orifices ;
- by a system for automatically blocking the lubrication oil injection channel, which also supplies oil to the pump. The operating principle is as follows (see diagram 2) :

- when the pump is rotating the oil exerts a resistive torque on the oil impeller cam wheel, preventing the cam from rotating. The eccentricity of the cam causes lever (1) to move and valve (3) to rise from its seat (C), so that oil flows in through the orifice (2).
- oil flowrate is controlled by an oil jet (50) mounted in the valve-seat (36) (see general drawing).
- when the pump is stopped, the oil impeller cam recenters because of its weight and the force of the spring : the lever returns, letting the valve drop back into its seat, preventing oil from entering.

2.5 GAS BALLAST

When condensable vapors are being pumped, in the "compression" phase gas is compressed beyond its saturated pressure and can condense, impairing pump performance.

The gas ballast allows a quantity of air to be injected into the second stage of the pump during "compression", to reduce the partial pressure of the pumped gas below its saturated vapor pressure and thus prevent condensation. In a single-stage pump the air is injected into the main stage.

At the end of "compression", the pressure in the discharge chamber is greater than atmospheric. An anti-suckback system (ball and spring) prevents gas and oil from being discharged into the environment (see diagram below).

The saturated vapor pressure of a gas is higher when it is hot when it is cold ; therefore, the pump must reach operating temperature before pumping condensable vapors.

Using the gas ballast increases the ultimate pressure of the pump as well as the temperature.

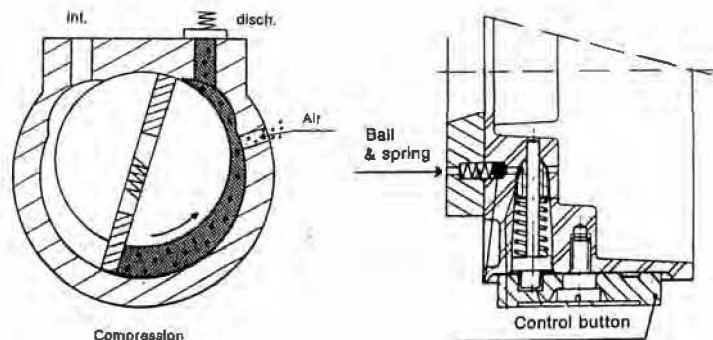

EL MOUNTING AND INSTALLATION

IMPORTANT NOTE :

For any application, pump performance will depend on :

- mounting conditions and accessories,
- type of oil used
- mechanical connections : vacuum lines, etc.

Read Sections III and IV before installing pump.
Contact Alcatel if there is any assistance required.

3.1 UNPACKING

Unpack equipment carefully upon receipt. Do not discard packing material until pump has been checked for damage in shipment. If damage is found, proceed as required with shipper and advise Alcatel if necessary.
Pump contains no oil when delivered ; oil is shipped in separate containers.

3.2 STORAGE

If the pump is to be stored, reliability without special storage precautions is guaranteed for up to 3 months at an ambient temperature of 5 to 40°C.

After six months, factors such as temperature, humidity, and salt air can cause deterioration of certain components : O-rings will harden, shaft seals will bond to shafts, and oil will become contaminated. A pump may experience operating difficulties under these conditions. Before it is started it will have to be disassembled (see § V) and all the seals replaced (see § 5.4).

Note 1 : We recommend keeping the pump filled with oil if it will be stored for longer than three months.
To do this, fill pump according to § 3.4.1 and run it for one hour at ultimate vacuum so that all the parts will be lubricated (see § 4.1). Then stop the pump and store it after sealing inlet and exhaust ports tightly (quick-connect clamp, centering ring, plug...).

Note 2 : Seal kits should also be stored carefully. Keep them away from heat and light (sunlight and ultraviolet) to prevent any hardening of the elastomers (see § 6.1)

3.3 CHOOSING THE OIL

3.3.1 Why Correct Oil is Important

Oil has numerous functions in the pump (see § 2.3). The correct oil is critical for a good vacuum. The choice depends on :

- chemical aggression and corrosion of the pumped products,
- used accessories,
- maintenance intervals that you want be compelled,
- total operating cost.

Different oils produce different partial pressures in the same pump. The partial pressure depends on the saturated vapor pressure of the oil, its viscosity, and its ability to dissolve gases. Synthetic oils in particular produce a significant rise in the ultimate pressure of two-stage pumps.

3.3.2 Recommended Oils

For the Standard pumps series Alcatel recommends oils listed in the table below. Oils with similar characteristics can be used, however.

OIL	APPLICATION	Influence on ultimate vacuum of a two-stage pump*	LIMITATIONS ON USE
ALCATEL 100	General purpose paraffin-based mineral oil • good base pressure • low backstreaming	$5 \cdot 10^{-4}$ mbar	Flammable
ALCATEL 102	Anti-emulsion mineral oil • drying • pumping water vapor • freeze-drying	$3 \cdot 10^{-4}$ mbar	Flammable
ALCATEL 111	Hydrocarbon-based synthetic oil with good heat resistance • pumping at high pressures	$2 \cdot 10^{-3}$ mbar	Flammable
ALCATEL 113	Highly stable synthetic oil Perfluoropolyether • highly inert to chemicals • pumping oxygen • plasma etching	$5 \cdot 10^{-4}$ mbar	Nonflammable For special preparation of pump see § 4.4
ALCATEL 200	Mineral oil vacuum distilled • pumping corrosive products • reduced backstreaming	$5 \cdot 10^{-4}$ mbar	Flammable
ALCATEL 300	Hydrocarbon-based mineral oil distilled under vacuum • pumping corrosive products • reduction of backstreaming • plasma etching • high temperature operation	$5 \cdot 10^{-4}$ mbar	Flammable For special preparation of pump see § 4.4

* Partial pressure measured by Pneuop method with a 2012 A ALCATEL pump.

However, ALCATEL 100 oil can be replaced by the following fluids :

- ELF MOVIXA PV 100
- TURBELF SA 100
- ELF BARELF F 100
- BP CS 100
- INLAND 15
- INLAND 19
- INVOIL 20
- SHELL VITREA 100
- TOTAL CORTIS 100
- INVOIL 20 (Registered Trademark INLAND).

In this case, the characteristics can be different from those listed on § 1.3 and in the table above.

3.3.3 Oxygen pumping

For certain applications, mixtures containing a certain concentration of oxygen or even pure oxygen are used.

Mineral oils are flammable; in addition they oxidize during pumping and rapidly lose their lubricating properties. **When the pumped gases contain more than 30 % oxygen, mineral oils should not be used.** The following synthetic oils or oils classed in the same category, should be used:

- ALCATEL 113 - FOMBLIN YL VAC 25.6* - KRYTOX 15-25** - DEMNUM S* 65*** - AFLUNOX 15.25****

Oils such as triaryl phosphate ester have already caused accidents; they should not be used.

Where use is intermittent, in case of intermittent pumping, we can use mineral based oils as ALCATEL 200 and ALCATEL 300.

To prevent oxygen from accumulating in the equipment, the oil casing must be fitted with a neutral gas (dry nitrogen) purge to dilute the oxygen. **The neutral gas flowrate must be about five times the oxygen flowrate.**

3.4 SETUP

3.4.1 Filling pump with Oil

Remove fill plug (16). Fill with oil to middle of sight glass (18). **This operation must be performed with pump stopped.** Do not over-tight the fill plug.

3.4.2 Mechanical Connections

a) Mounting on a Frame

The pump can be mounted on a frame by using the 4 mounting holes in base (3) and 4 special shock mounts (see § 3.4.3).

NOTES: These mounts reduce the pump vibrations but will not hold the pump securely when the pumping assembly is moved. Clamp pump to frame before moving.

b) Ventilation

The pump and motor are equipped with a ventilation system. When the pump is installed, the pump should be placed in a ventilated location.

Check ventilation holes on the pump and motor periodically for obstructions.

Alcatel pumps are designed to operate at an ambient temperature of 10 to 40°C. If the temperature is likely to rise above 40°C, an auxiliary cooling device can be used (see § 3.4.3).

c) Inlet and Exhaust Ports

The pump inlet and exhaust ports are equipped with ISO NW 40 nipples for Pneurop quick connectors to accept various stainless steel, plastic, etc. tubing accessories (see diagram 7).

* Registered trademark of MONTEDISON

** Registered trademark of DU PONT DE NEMOURS

*** Registered trademark DAIKIN

**** Registered trademark SCM

3.4.3 Accessory Table

Description	Part Number	Location	Function
Oil mist eliminator	068316	exhaust	• separates oil droplets and contaminant particles in exhausted gases from the mechanical vacuum pumps.
Dust filter	068440	inlet	• prevents dust particles larger than 6 microns from accumulating in the pump and oil.
Liquid nitrogen trap	786538	inlet	• protects pump against condensable vapors. • prevents oil from backstreaming into pumped chamber.
Molecular sieve filter	053379	Inlet	• prevents oil backstreaming (when used to back a diffusion pump or TMP).
Remote controlled gas ballast	068395	on frame	• facilitates pumping condensable vapors, regenerates pump oil, by remote control.
Oil filter (DE)	068990 (220 V) 068991 (115V)	external device	• filters oil when pumping gases containing dangerous dusts which could rapidly degrade oil quality.
Auxiliary cooling device	054257	between frame and motor	• when operating at ambient temperatures above 40°C, a water cooling ring can be fitted.
Shock mount	082691 (APEX LXA 88 Mod. D)	between base and machine frame	• allows pump to be mounted on a frame.
Shock mount (special)	052996	between pump frame and machine frame	• to be used when even the slightest vibrations must be eliminated (with TMP) (high-performance shock mount).

In general, use accessories whose tightness and materials are compatible with the pumped gases at both the inlet and exhaust. At the pump exhaust, the discharge circuit must be such that the resulting overpressure in the oil case is less than or equal to 0.5 bar relative pressure.

See table "Selecting pumps and Accessories for Specific Applications" at the back of this manual (diagram 6).

3.4.4 Electrical connection

Generally speaking, the motor should be fused for 120% of its rated current.

For series motors, see table "Protection of Electric Motors (see diagram 5).

a) Three-Phase Version

Hook up motor according to line voltage. The connections are shown on the schematic located inside the terminal box or on the lid.

The pumps are delivered with their motors connected to maximum voltage. Switch on current briefly to check motor rotation direction. The end of the shaft must rotate in the direction of the arrow on the motor mounting plate.

b) Single-Phase Version

The motors are wired for the voltages shown in diagram 5. They are supplied with a 6-foot power cord. The plug is equipped with a ground pin which **must** be connected. The motor rotation direction is set at the factory.

IV. OPERATION AND MAINTENANCE

4.1 STARTUP

4.1.1 Temperatures

Starting : Be sure oil bath temperature is above 10°C before starting motor.

- **The ambient temperature where the pump will be used must be between 10 and 40°C.**

- Under these conditions, the pump temperature (measured at the front flange) must be between 60 and 80°C (depending on operating conditions).

Special Case - Synthetic Oils

See also § 4.4.b.

These oils are much more viscous when cold than mineral oils. In addition, to improve pump lubrication when starting, add several cc's of oil through the intake.

For the same reason, avoid starting the pump at ambient temperatures below 18°C.

4.1.2 Starting

- Check direction of rotation of motor.

- It is normal for the oil level to rise when hot (within the limits of the sight glass) because the oil expands.

If problems occur, see § VII "Troubleshooting".

4.2 OPERATION OF GAS BALLAST

4.2.1 Starting

The principle of the gas ballast is described in § 2.5. When the pump is new or has not been operating for a long time, vapors or condensates may have entered the pump by condensation.

These substances mix with the oil and impair the pump characteristics. To regenerate oil, start pump at ultimate vacuum with inlet port blocked; make sure it starts if the oil is especially cloudy or contaminated. Then, with the pump hot (after running for one hour), run pump for about half an hour to one hour (depending on the degree of contamination) with gas ballast wide open. This procedure expels most condensable products. Then close the gas ballast control knob (0) to restore the pump to ultimate vacuum.

4.2.2 Pumping Condensable Vapors

When condensable substances are being pumped, the condensates will mix with the oil and impair the pump characteristics.

To prevent this, do the following :

- **Selecting the pump.** If the pump is to be used to pump large quantities of condensables, use of a single-stage pump is recommended.

The single stage pump allows the pumped gases to bypass the functional assembly of the pump without condensing between two stages.

With ample lubrication, their performance with the gas ballast is improved. On the other hand, the ultimate pressure which can be achieved will be less than with a two-stage pump.

- **Choice of oil :** use an oil which is not miscible with the pumped substances (see § 3.3.2).

- **Pump's exhaust assembly :** avoid overpressure.

Proceed as follows :

• remove valve (14),

• do not use oil mist eliminator (use a condenser instead a inlet),

• make sure there are no vertical lines allowing products to condense and return to the pumps oil casing.

• use a fume exhaust.

- **Startup :** Proceed as § 4.2.1.

- **During pumping :** Monitor oil level. It may rise if all the pumped condensates have not been vented.

- **After pumping :** Operate pump disconnected from system for 1/2 to one hour with gas ballast fully open. This regenerates the oil. Then close gas ballast, stop pump, and drain condensates and oil-condensate mixture (see § 4.5). As soon as clear oil appears at the drain port, close it and top off with fresh oil (procedure can be facilitated by fitting a drain cock to the drain port (connection G 3/8").

- **Restarting :** If pump is still doesn't perform according to specifications, the oil is completely contaminated. Drain flush (see § 4.6) then fill with fresh oil.

4.3 HIGH-PRESSURE PUMPING ($P > 30$ mbar)

With the pump is operating at high pressure ($P > 30$ mbar) performance depends on the internal clearances in the pump ; the oil which is partially penetrated by gases, serves only for lubrication. As the pump heats up the oil becomes thinner, and splashing and misting losses increase.

Intermittent Pumping

If the pump operates only a short while at high pressure, top off with lubricating oil following the return to low pressure. Use an oil mist eliminator to prevent splashing and misting losses (see § 8.2).

Continuous Pumping

If the pump operates continuously at high pressure, oil consumption can become considerable, to the point where the level falls in the oil casing. Lack of oil may cause the pump to seize. In addition, the high gas flow through the separator prevents the oil from returning to the casing.

The pump and its oil eliminator must be modified for pumping under these conditions, as shown in the following diagram.

The pump under these conditions the pump and oil mist eliminator must be modified as shown in the diagram below.

A device of this type draws the oil from the eliminator through the pump for lubrication.

The components of a system of this kind will depend on the ultimate vacuum desired, the volume of gas pumped, and the oil used. Other arrangements are possible; contact Alcatel for assistance.

HIGH PRESSURE PUMPING : Example of oil recovery device (WARNING : The pump is not airtight).

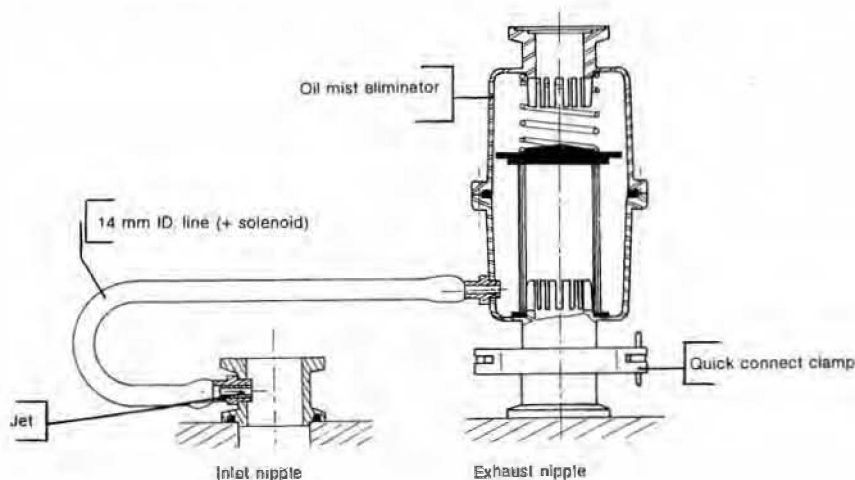

4.4 CHANGING FROM ONE TYPE OF OIL TO ANOTHER

ALCATEL pumps are tested with ALCATEL 100 oil ; a certain amount remains in the moving parts of the pump.

If you must use a different type of oil, proceed as follows :

a) When oils are compatible

This is the case when one mineral oil is replaced by another (for example ALCATEL 100 by ALCATEL 102).

Simply flush pump (see § 4.6) using new oil, then fill (see § 3.4.1).

b) When oils are incompatible : synthetic oils or similar oils

This is the case when a mineral oil is replaced by a synthetic oil (for example ALCATEL 100 by ALCATEL 113).

Synthetic oils are considered mutually incompatible for practical reasons, and they are expensive. Mixing them could cause cloudiness, which could be misinterpreted as a sign of contamination or degradation.

For the same reasons, the clear oils of mineral (Alcatel 300) also expensive, will be considered as synthetic oils.

These remarks apply to these oils : ALCATEL 111, ALCATEL 113, ALCATEL 300, FOMBLIN YL VAC 25-6*, INLAND TW, KRYTOX 15-25**, DEMNUM S 65***, AFLUNOX 15.25****.

These oils are generally used in Chemical Series pumps. They can also be used in standard pumps ; proceed as follows :

- Completely disassemble and clean pump (see § V).
- Change all seals (§ 5.4) and replace them by Viton seals. For this, order a seals kit for chemical pump, P/N 052624.
- Reassemble but remove middle jet (49) and jet (50) : replace the latter by jet P/N 052758.
- Then fill with new oil (see § 3.4.1).

Note : to replace a synthetic oil by a mineral oil, proceed as described in § 4.4.a).

* Registered trademark of MONTEDISON.

** Registered trademark of DU PONT DE NEMOURS.

*** Registered trademark of DAIKIN

**** Registered trademark of SCM

4.5 OIL LEVEL - DRAINING

a) Oil Level

To use pump under optimum conditions, check oil level in oil sight glass periodically. **Perform when pump is not operating.**

- Oil consumption may vary with conditions. Use of an oil mist eliminator can substantially reduce oil consumption by allowing oil to flow back into the oil casing.
- Periodic inspection enables the oil color to be compared with a sample of fresh oil. It indicates the degree of contamination or degradation.

If the oil is slightly cloudy (a sign condensables are being absorbed) it can be regenerated with a gas ballast (cf. § 4.2).

If the oil is brown, blackish, or smells "burnt" it has deteriorated. In this case, drain pump and rinse if necessary.

b) Draining Procedure

The pump must be drained when hot and after the oil case has been vented to atmospheric pressure. First, isolate or disconnect the pump from the system. Then :

- tilt pump ;
- unscrew drain plug (16) on oil casing. When all the oil has drained, replace plug (16) temporarily and run pump for about 10 seconds leaving inlet port open. This removes the oil from the pumping module ;
- drain oil by removing plug (16) ;
- replace plug, then fill with fresh oil to the middle of oil sight glass (18).

4.6 FLUSHING

Draining can be followed by rinsing if the oil is particularly dirty. This operation requires a volume of oil equal to the capacity of the pump. After draining oil casing (see § 4.5) replace plug (16). Run pump at atmospheric pressure allowing fresh oil to flow slowly into inlet port (100) after cleaning filter (29). Stop pump and drain flushing oil. Replace plug and top off with fresh oil according to § 3.4.1.

V. DISASSEMBLY, CLEANING AND REASSEMBLY

IMPORTANT ! Before doing any maintenance task, check the pumping conditions of the installation : toxicity, corrosion, possible radioactivity of pumped gases. Proceed as follows, depending on the specific case :

- flush system with dry nitrogen before doing any work on it ;
- wear gloves, goggles, and a mask if required ;
- ventilate area thoroughly and disassemble equipment beneath a fume hood if necessary ;
- collect residues in appropriate containers.

Routine maintenance of Alcatel 1004 A, 2004 A, 2008 A, 1012 A, 2012 A and 2020 A requires only periodic oil changes.

In the event of heavy contamination, wear, or an operating breakdown, the pump must be disassembled (see § VII).

Replace all seals whenever the pump is disassembled (see § 6.1). The only tools needed are a few wrenches, found in any maintenance shop (see § 5.6).

Before disassembly, drain oil (see § 4.5).

The first step is to remove the moving parts from the oil case. The second step is to disassemble the moving parts.

5.1 DISASSEMBLING MOTOR-PUMP ASSEMBLY

(see general drawing)

- Stand pump on end with motor at top, resting on front of oil case. This greatly facilitates the first phase of disassembly.
- Remove 4 nuts (H).
- Remove handle plate (4) together with motor. Be careful not to damage flat gasket (12). The two parts of the motor coupling separate, one on the motor side and the other on the pump side. Pumps with an American standard motor have an adapter plate (114) between handle plate (4) and motor.
- Set pump on base and remove oil case (2).

5.2 DISASSEMBLING MOVING PARTS

- Remove base (3) by unscrewing screw (A).
- Rotate fan (9) until set screw (F) can be unscrewed from bottom of pump.
- Remove fan coupling (9) and spline (19).
- Remove felt (11) and throw it.
- Unscrew screw (B) and remove retaining bracket (30).
- Remove inlet plate (100), filter (29), and exhaust plate (103).
- Remove valve cover (60) by unscrewing screws (E).
- Remove valve springs (61) and valves (57) (1004 A Pump : 1 valve).

- Disassembling Gas Ballast

- Remove screw (21).
- Remove knob (20), piston (22), spring (24), and flap valve (23).

- Disassembling Sealing System

Note : The sealing system is set at the factory. It must be reset after disassembly (see reassembly, § 5.5 g). For sealing system maintenance, see § 6.3. However, rear plate can be disassembled without altering the setting of the sealing system.

• Remove impeller cam (32) by removing circlip (34), leaving anti-suckback lever (54) in place.

Do not remove the oil jet (50) for cleaning. When reassembling, spray with a jet of compressed air to remove any obstructions.

- Removing Rear Plate (39)

- Unscrew three nuts (G).
- Insert two screwdrivers into the two notches. Twist simultaneously screwdrivers to remove plate alignment pins. Remove flange straight retaining HP Rotor (35). Remove O-ring (55).

5.2.1 Disassembling Two-Stage Pumps 2004 A, 2008 A, and 2012 A, 2020 A.

- a) **Removing HP Rotor (35)**
 - Remove rotor (35) by sliding it out off stator.
 - Remove vanes (47) and springs (46).
- b) **Removing HP Stator (40)**
 - Insert two screwdrivers into the two notches in stator (40) and proceed as in § "Removing rear Plate".
 - Remove O-ring (55).
- c) **Removing Central Plate (41)**
 - Insert two screwdrivers into the two notches and proceed as in § "Removing rear Plate". Remove O-ring (55).
 - Oil jet (49) lubricates the first stage. Do not remove it for cleaning. When reassembling, spray with compressed air to remove any obstructions.
- d) **Removing LP Rotor (44)**
 - Remove rotor (44).
 - Remove vanes (48) and springs (46).
- e) **Removing LP Stator (42)**
 - Insert two screwdrivers into the two notches and proceed as in § "Removing rear Plate". Remove O-ring (55).
- f) **Removing Front Plate (43)**
 - Insert two screwdrivers into the two notches and proceed as in § "Removing rear Plate".
 - Remove spring (26) and gas ballast bearing (25).
 - Remove O-rings (55) and (56).

IMPORTANT NOTE : 2004 A Pump

When reassembling, do not confuse HP stator (40) and LP stator (42). HP stator (40) has an additional hole to admit air from gas ballast.

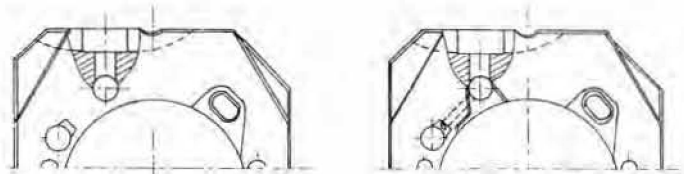

STATOR LP 42

STATOR HP 40

5.2.2 Disassembly of Single-Stage Pumps : 1004 A and 1012 A

- a) **Removing Rotor**
 - Remove rotor (52) by sliding it out off stator.
 - Remove vanes (47) and springs (46).
- b) **Removing Stator**
 - Introduce two screwdrivers into the two notches on stator (52) and proceed as in § "Removing rear Plate".
 - Remove O-ring (55).
 - Since the clearances are particularly tight in the 1004 A and 1012 A pumps, rotors and stators are sold only as matched pairs.
- c) **Removing Front Plate (43)**

See § 5.2.1 f).

5.3 CLEANING METAL PARTS

Metal parts are cleaned with solvents. Conform to safety instructions of solvents vendor for using these solvents.

- After using mineral oils, clean metal parts while cold with solvents such as AXAREL 6100*, PRIMACLEAN**.
- After using synthetic oils (see § 4.4 b), clean metal parts while hot with solvents such as trichloroethylene or perchloroethylene. If any traces of oil remain after cleaning, remove with GALDEN S90*. Cold cleaning can also be done with GALDEN S90*.
- Coldcleaning: clean parts by dipping and using brushes (do not use rags).
- Hotcleaning: use appropriate equipment and take the necessary precautions for hot cleaning.

5.4 REPLACING SEALS AND OTHER ELASTOMER PARTS

ALWAYS REPLACE ALL SEALS WHEN DISASSEMBLING PUMP

If an elastomer part must be reused (seals, valves, etc.), never clean it with a solvent before determining the effect (if any) of the solvent on the characteristics of the elastomer.

We cannot guarantee correct pump performance under these conditions.

5.4.1 O-Rings

Shore hardness is between 60 and 70. O-rings must not be scratched or cracked, and must be circular in cross section. Never use a cord with an oval cross section.

5.4.2 Shaft Seals

Disassembly

- Place part (frame or plate) flat on a work bench.
- Place a washer (12 x 20 x 2 mm) on seal as a support.
- Insert one end of a screwdriver under shaft seal.

IMPORTANT :
Be sure not to damage seal seat during removal.

- Use screwdriver as a lever: press against washer, pry loose, and discard (see Diagram 4).

Fitting a New Seal

- Clean seal seat and smooth any rough edges.
 - Lubricate bore and entire seal.
 - Position seal correctly (see general drawing).
 - Mount oiled seal on mounting tool.*
 - Locate seal opposite seat and install:
 - either with a press and the proper mandrel (case 2, diagram 4),
 - with a drill press, or
 - by striking mandrel (case 1) with a mallet. In this case, keep tool perpendicular to flange.
- Note: To remount plates and LP roto (44) in frame (1), use protective sleeve or wrap end of shaft with adhesive tape.

Replace shaft seal (27) on fan side :
This Viton seal is located in the frame (1).

- * Registered trademark of Du Pont de Nemours
- ** Registered trademark of Dow Europe.

5.4.3 Flat Gasket

a) Disassembly

Replace oil casing gasket (5) each time pump is disassembled. If necessary, clean oil casing and plate sealing surfaces; rub with a piece of wood or plastic to remove scratches. The casing gasket must be changed each time the motor is mounted or removed, since the casing assembly is integral with the motor assembly.

b) Reassembly with a new casing gasket (5)

- The sealing surfaces of the oil casing must be clean and free of scratches.
- Place the casing gasket (5) over the oil casing studs and position it on the oil casing. The casing gasket is mounted dry. Do not use any lubricant or sealant.
- Install the oil casing on the central housing. The gasket has to be properly aligned with the sides of the pump to insure a good seal.
- Tighten the nuts (H) with enough force to compress the casing gasket and insure a good seal (see § 5.5 maximum torque).

5.5 REASSEMBLY

Oil used for lubricate pump parts must be the same as oil used for pump operation.

Before reassembly:

- a) All parts must be dry so that no solvent remains, particularly in blind holes.
- b) Do not put too much oil in the bottoms of the holes for the plate/stator alignment pins.
- c) Coat all pump parts and seals with clean oil. Make sure seals are correctly installed (see general drawing). The Viton shaft seal (27) is mounted in the front of plate (1).
- Fill lubrication holes of seals and bearings in flange with oil.
- d) Tighten nuts (K) without forcing (maximum torque 1 mdaN).
- e) Reassemble in reverse order. Before positioning valves, add a little oil to stators through the discharge valve holes.
- f) Fan assembly (see diagram 3)
 - Engage felt (11) totally in the housing-notch, keep care that it doesn't touch the fan.
 - Install fan and its shaft key without block them.

Assembling a European Motor (Figure 1)

- Place coupling sleeve (111) such that it abuts shoulder of motor shaft if motor has been disassembled.
 - Provide 0.5 to 1 mm clearance between frame and fan coupling. This clearance should be measured between the internal surface of the frame (1) and the surface of fan (9) opposite the arms.
- #### Assembling a U.S. Standard Motor (Figure 2)
- Place coupling sleeve 23^{+0.1/-0.5} mm from the upper surface of handle plate (4) after setting adapter plate (114) in place.
 - Provide 0.5 to 1 mm clearance between frame and fan coupling.
- g) Reset sealing system (if it was completely disassembled); see diagram 2.
 - Expert a slight pressure F to off-center the cam.
 - Turn pump shaft until lever (54) moves to its maximum extent.
 - The maximum space between seat (C) and valve (3) must be 0.9 to 1.2 mm. It is adjusted by changing the position of support (1).
 - The axis of the oil inlet hole must be perpendicular to the surface of valve (3). Adjust by changing the position of seal (C).
- After these adjustments, check that when pressure F is released, valve (3) returns to seat (C).

- h) Do not remove aluminium partition (65) or seal (12): the partition must be on the fan coupling side.

5.6 TOOLS

The tools required to disassemble and reassemble the motor-pump assembly are as follows:

- screwdrivers
- open-end wrenches: 13-10 on flats
- wrenches for hollow hex screws: 6-5-3 on flats
- pliers for circlips, I.D. 26 mm.

Special ALCATEL Tools (see diagram 4)

To mount shaft seals, Alcatel provides special tools:

- washer P/N 073348
- protective sleeve P/N 052994
- mounting tool P/N 052993

Tool kit No. 052995.

VI. SPARE PARTS

For fastest service, specify the following when ordering :

- pump type

- serial number (on label)

- part number (see list at end of book).

Maintenance kits containing the most frequently used parts are available at our sales outlets. Be sure to use these kits so you will have all the parts necessary when servicing is required.

6.1 SEAL KIT (Diagram 8)

No. 052610

Contains all pumps seals for complete disassembly.

Seal kits should be stored carefully. Store them away from heat and light (sunlight and ultraviolet) to prevent any hardening of the elastomers (see AFNOR standard : "Conditions for Storing Vulcanized Elastomer-Based Products" NF T 46022).

6.2 MAINTENANCE KIT (Diagram 8)

In addition to seals this kit contains a set of spare parts for pump maintenance for up to two years of normal use.

Pumps	1004 A	1012 A	2004 A	2008 A	2012 A	2020 A
Kit n°	052615	052612	052614	052613	052611	052982

6.3. ANTI-SUCKBACK SYSTEM KIT

This kit includes sealing system parts (see diagram 2); equipped with cover (54), impeller (32) and stopnut (34).

Pumps	1 and 2 stages inferior to 50 000	1 stage superior to 50 000	2 stages superior to 50 000
Kit No.	052966	052968	052967

VII. TROUBLESHOOTING

PROBLEM	CAUSE	REMEDY	SECTION
A. PUMP DOES NOT ROTATE	<ol style="list-style-type: none"> Motor Improperly wired Pump seizes as a result of stoppage after pumping under difficult conditions (without cleaning or flushing) Coupling deteriorated Temperature too low Oil contaminated Oil thickened following prolonged storage or by being left to stand after pumping contaminants 	<p>Check wiring Disassemble, clean, and smooth scratched metal parts (replace them if necessary), then reassemble Replace it disassembling the motor</p> <p>Use gas ballast or change oil and rinse pump</p> <p>Disassemble and clean</p>	<p>§ 3.4.4</p> <p>§ V § 4.1.1 § 4.2 or § 4.5 and 4.6 § V</p>
B. PUMP DOES NOT MAKE VACUUM	<ol style="list-style-type: none"> Ultimate pressure obtained : few mbar <ol style="list-style-type: none"> Insufficient oil in casing Oil contaminated Oil cold, oil inlet obstructed Inlet filter obstructed One of the LP valves has deteriorated Part omitted in reassembly Motor rotates in wrong direction Motor underpowered Ultimate pressure obtained : 10^{-2} mbar (2 stages) or 10^{-1} mbar (1 stage) <ol style="list-style-type: none"> O-ring pinched One of the shaft seals has deteriorated One of the HP valves has deteriorated Gas ballast valve open Lubrication holes blocked Poor adjustment of oil inlet system Part omitted in reassembly Accessories <ol style="list-style-type: none"> At the pump exhaust, the resulting pressure is up to 0,5 bar Cartridge of oil mist eliminator clogged 	<p>Top up Case A.5</p> <p>Clean Replace Reassemble again Change two phases Check wiring</p> <p>Replace Replace Replace Close Disassemble and clean Readjust Case B.1.6</p> <p>Check installation Replace</p>	<p>§ 3.4.1</p> <p>§ 4.1.1 § 5.3 § V § 5.5 § 3.4.4 § 3.4.4</p> <p>§ V</p> <p>§ V § 5.5 g)</p> <p>§ 3.4.3 and § 8.2.4</p>
C. PUMP NOISY	<ol style="list-style-type: none"> Oil overly contaminated (solid particles) Motor improperly powered Motor bearings damaged Coupling poorly adjusted or deteriorated Bas fan mount Poor adjustment of oil inlet system Vanes derteriorated 	<p>Case A.5 Case B.1.8 Replace Check adjustment Check mount Readjust Replace</p>	<p>§ 5.5.f) § 5.5.f) § 5.5.g) § V</p>
D. PUMP TOO HOT	<ol style="list-style-type: none"> High pressure operation Oil polluted Wrong oil Pump located in poorly ventilated area Vent openings blocked Supply voltage too high Overpressure at the pump exhaust 	<p>Use a oil mist eliminator or a auxiliary cooler Case A.5 Change oil Check installation</p> <p>Check voltage, replace motor Case B.3.1</p>	<p>§ 4.3 or § 3.4.3</p> <p>§ 4.4 § 3.4.2 b)</p> <p>§ 3.4.4</p>
E. HIGH OIL CONSUMPTION	<ol style="list-style-type: none"> High pressure operation Pump too hot Leak at housing seal or shaft seal 	<p>Case D.1 Case D Replace</p>	
F. POOR PUMP SEAL WHEN STOPPED	<ol style="list-style-type: none"> Anti suckback system poorly adjusted O-ring pinched One of the valves has deteriorated One of the shaft seals deteriorated Oil contaminated Gas ballast knob open 	<p>Case B.2.6 Case B.2.1 Case B.1.5 Case B.2.2 Case A.5 Case B.2.4</p>	
G. OIL PRESENCE IN THE EMBASE	<ol style="list-style-type: none"> Oil casing gasket deteriorated Shaft seal deteriorated and felt saturated 	<p>Disassemble oil casing, clean plate surfaces and reassemble with a new gasket Change both</p>	<p>§ 5.1 and § 5.4.3 § 5.2 and § 5.4.2</p>

VIL ACCESSORIES

8.1 REMOTE CONTROLLED GAS BALLAST

8.1.1 Description

Designed for remote control of gas ballast during frequent operation or when manual gas ballast is difficult to reach. Its operating principle is identical to that of the manual gas ballast (see § 2.5).

8.1.2 Technical Data

Part number	068395
Weight	250 g
Material	stainless steel
Power supply	220 V, 50 Hz or 60 Hz (options available)
Dimensions	see figure

8.1.3 Installation

The remote controlled gas ballast is installed at the factory as an option when ordering the pump. It is mounted in place of the manual gas ballast using the same mounting screw (21) and the same spring (24).

Installation requires disassembling the pump and tapping the frame. Installation is as follows :

- Disassemble pump as described in § V.
- Remove manual gas ballast assembly from frame by unscrewing screw (21) (be sure to remove valve (23) from the bottom of its seat).
- Clean frame.
- Tap air inlet hole (5 mm diam. x 5 mm) and clean.
- Lock screw (G) using Loctite 542 but do not screw down fully : leave several tenths of a mm at the bottom of the seat.

- Insert remote controlled gas ballast assembly into hole and secure with screw (21)
 - Reassemble pump as described in § 5.5.
 - Plug in coil.
 - Check tightness as follows :
 - Connect a manometer to pump inlet ; run pump until temperature is stable with gas ballast open.
 - Stop pump. Pressure must not have risen by more than 20 mbar after 24 hours.
- NOTE :** If there is a leak at seal (C) add a washer (J) to the existing washer.

8.1.4 Maintenance

Limited to periodic cleaning to ensure proper gas ballast function. Proceed as follows :

- Disconnect power leads
- Remove set screw (21) and remove gas ballast assembly (B) from pump
- Clean passage (D) with solvent
- Replace seals (C) and (H)
- Degrease filter (E) with solvent and dry with compressed air
- Reassemble in reverse order.

8.1.5 Spare Parts

Reference	Part Name	Part Number
H	Seal	082106
C	Seal	079069
J	Washer	073339

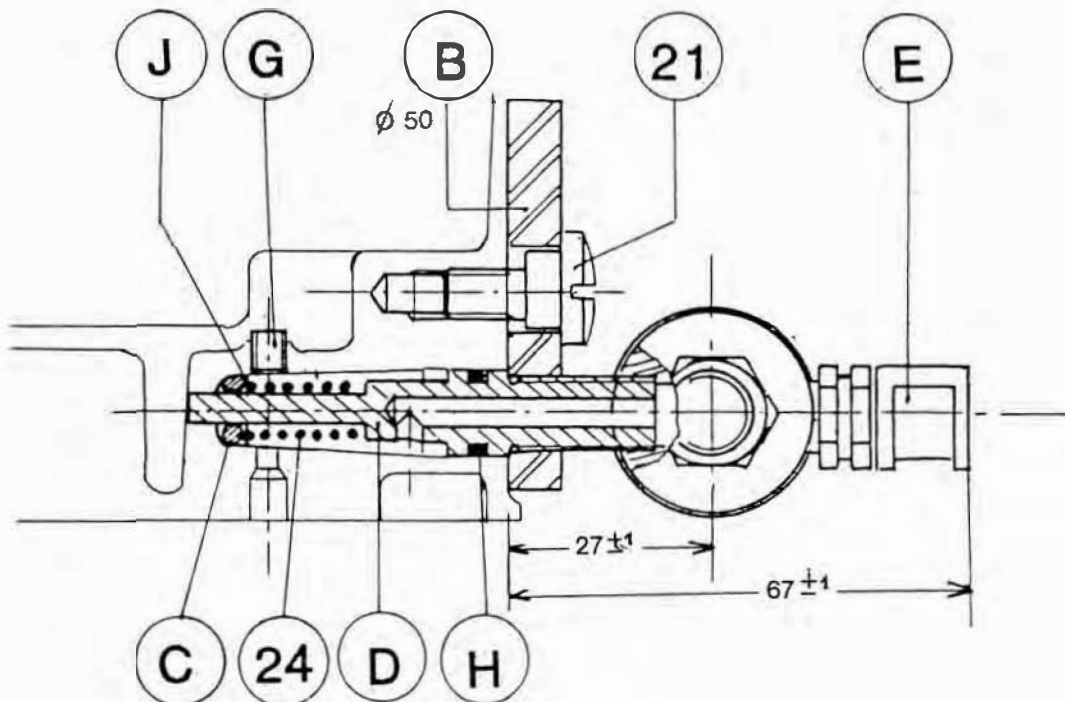

8.2. OIL MIST ELIMINATOR

8.2.1 Characteristics

Dimensional diagram : figure 1

Part number : 068316

Weight : 140 g

Connection : Pneurop NW 25

Material :

- body : polycarbonate

- cartridge : glass microfibers + epoxy binder

Mounting on pump : black side with "Pump ↓" label

Delivered with :

- 1 exhaust hose (K) 052753

- 1 locking collar NW 25 (J) 083264

8.2.2 Description

- The oil mist eliminator separates oil droplets and particles of deposits in the exhaust gases from oil-sealed roughing pumps.

- When the eliminator is mounted vertically above the pump the condensed oil flows back from the cartridge into the oil case if the inlet pressure is less than 1 mbar for a sufficiently long time.

- The eliminator has a safety valve (D) set to 0.2 bar relative pressure which prevents overpressure in the pump oil case when the latter is transferring vapors which might clog the cartridge. Do not allow solid or pasty deposits to stick the valve to the filter.

8.2.3 Installation

Remove exhaust valve (14) from pump exhaust port.

Direct installation is shown in Figure 2. Installation according to Figure 3 is recommended when the dimensions of the exhaust port do not permit direct installation. In this case, remove exhaust flange (103) and valve pin (13) but use seal (H) located on this flange. Then install according to Figure (3). When using an oil mist eliminator, if the pump is connected to a chimney or ventilating duct, check to be sure the pressure loss does not exceed 300 mbar.

a) Cartridge Saturation

If excessive fumes or droplets appear at eliminator outlet, the cartridge is saturated. Saturation depends on the number of pumping operations, the volume of gas pumped, and the condition of oil. When the cartridge is saturated, replace as follows :

b) Disassembly

Remove assembly screws (A) then remove in order : upper body (B), spring (C), valve plate (D), valve (L), cartridge (E) and its flatgasket (M), o-ring (F).

c) Cleaning

- **Never clean filter cartridge. Always install a new one.**

- Clean the parts with a dry rag and, if necessary, with Freon 113^{*}.

- Seals (F) and (M), **must** be replaced by news.

d) Reassembly

In lower body (G), place seal (F) in its groove and center flatgasket (M). Install a new cartridge (E) pressing it lightly so that it rests on the gasket. Place valve plate (D) on valve (L) and fit them on cartridge. Center spring (C) on valve (D). Replace upper body (B) and assemble with screws (A).

8.2.5 Applications Not Recommended

Use of an oil mist eliminator is not recommended in the following cases : drying, freeze-drying, pumping condensable gases, impregnation with polymerizable resins, and debubbling monomers.

Filter cartridges are flammable ! Do not use eliminators when pumping oxygen or silane or for pumping corrosive products or LPCVD.

8.2.6 Spare Parts

Reference	Part Name	Part Number
E	Filter cartridge	068304
F	Seal	079015
L	Valve	054134
M	Flatgasket	052117

* Registered trademark DU PONT DE NEMOURS.

DIMENSIONS
Figure 1

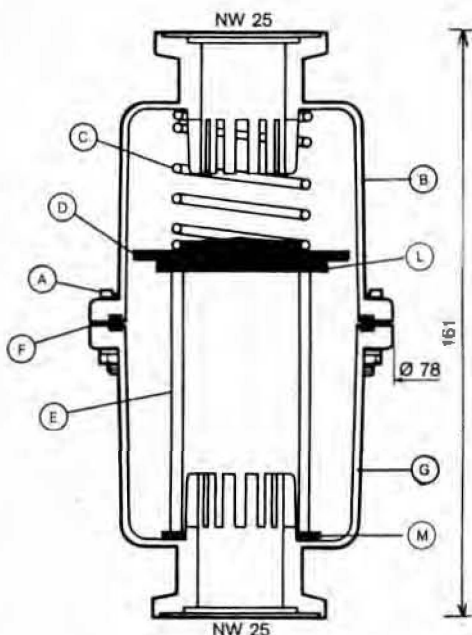

DIRECT ASSEMBLING
Figure 2

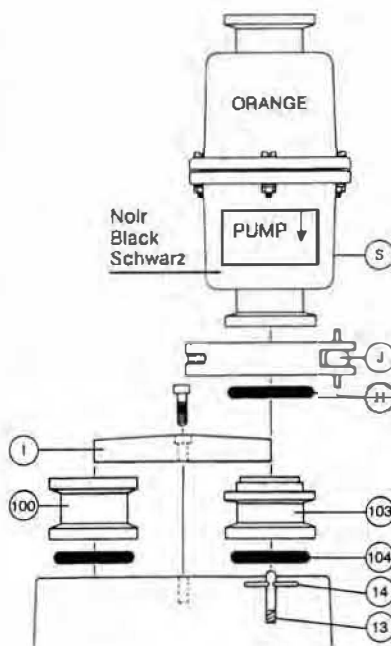

OFFSET ASSEMBLING
Figure 3

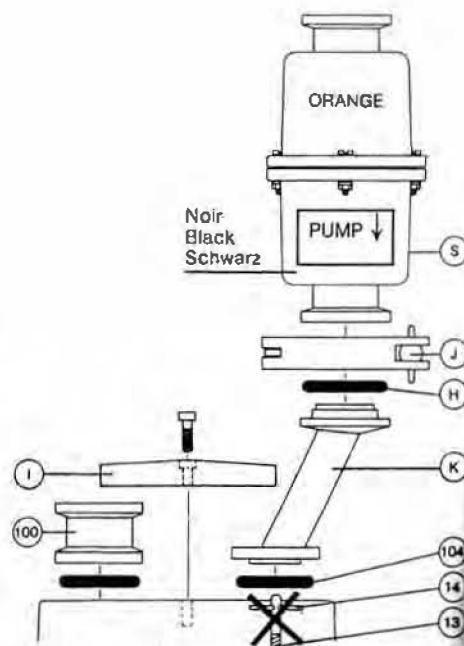

8.3 LIQUID NITROGEN TRAP NW 25

8.3.1 Description

The liquid nitrogen trap is mounted on the intake of a mechanical roughing pumps 4, 8, 12, 20 m³/h. Made entirely of stainless steel (removable), it has the advantage of consuming very little liquid nitrogen.

8.3.2 Characteristics and part number

Dimensions : see figure 1.

Connections : NW 25 Pneurop (inlet/exhaust).

Weight : 2,4 kg.

Liquid nitrogen capacity : 1 liter.

Conductance at 10⁻¹ mbar : 35 l/s.

Autonomy (P < 10⁻⁴ mbar) : 15 hours.

Pumping speed (water vapor) : 4 l/s.

Part number : 786538.

8.3.3 Operating principle

The liquid nitrogen trap is used for cryogenic pumping of vapors and gases with condensation temperatures above 77 K (temperature of liquid nitrogen). It therefore increases pumping speed for these vapors or gases.

It protects the pump against condensable vapors that could be entrained during pumping.

It prevents oil from migrating into the vacuum system by means of back diffusion.

8.3.4 Installation

- Accessories whose tightness and materials are compatible with the pumped gases and the required safety conditions must be used upstream and downstream of the trap.
- Read § 8.3.5 and 8.3.6 before installing liquid nitrogen trap.
- The trap openings are provided with ISO NW 25 flanges for Pneurop type quick connect clamps, allowing various fittings to be connected (see diagram 7).
- See figure 2.

8.5 Operation

Important note : in general, the trap should not be used at pressures above some mbar, because it becomes contaminated very rapidly under these conditions.

A system with a by-pass valve should be used, or the trap should not be filled until the pressure is sufficiently low.

a) Filling with liquid nitrogen

- Lower pressure in trap until it is nearly 10⁻¹ mbar.
- Fill trap with liquid nitrogen.
- Use a funnel or filling tube less than 14 mm in diameter.
- Let trap cool, then top up a few minutes later.

b) Time between recharges

The time between recharges depends on the following :

- frequency of use,
- operating pressure (operation at high pressure causes more rapid contamination),
- nature of pumped gases (quantity of condensable vapor).

For pumping on a clean chamber at ultimate vacuum, the trap can be used for 12 to 15 hours between recharges.

8.3.6 Maintenance

IMPORTANT : each time the system is dismantled, take all necessary precautions to ensure safety and protection of personal against possible toxicity, corrosion, and radioactivity of residues.

Proceed as follows :

- Purge system with dry nitrogen before working on it.
- Wear gloves, goggles and mask.
- Ventilate area thoroughly and disassemble parts under a fume hood.
- Collect residues in appropriate containers.
- Do not simply discard residues, and have them destroyed by a competent organization if necessary.

Important note :

Do not do the following when using a trap :

- close trap under vacuum when cold, and allow to warm up : if the pumped products are in the gase phase at room temperature, overpressure will be created in the trap which depends of the saturated pressure from pumped products.

Cleaning procedure :

- With trap cold, break vacuum with dry nitrogen.
- Isolate trap by closing isolation valves.
- Disconnect trap from system.
- Open valves under a fume hood and allow trap to warm up. The condensed products will liquefy.
- Tilt trap and drain impurities.

After using mineral oil, dip trap in a solvent such as 1.1.1. trichloroethane or 1.2. dichloroethane (cold cleaning).

After using synthetic oils (Alcatel 113, Fomblin YL VAC 25-5*, Fomblin YL VAC 25-6*) clean parts when a solvent such as trichloroethylene or perchloroethylene.

During hot cleaning, use appropriate equipment and take necessary precautions. If traces of oil remain after cleaning, remove them with Freon 113**.

Freon 113** can also be used for ordinary cold cleaning.

- Rinse trap with alcohol and dry thoroughly.
- Replace trap in system.
- Close isolation valve above the trap and pump down again to degas trap.

* Registered Trademark of Montedison.

** Registered Trademark of Du Pont de Nemours.

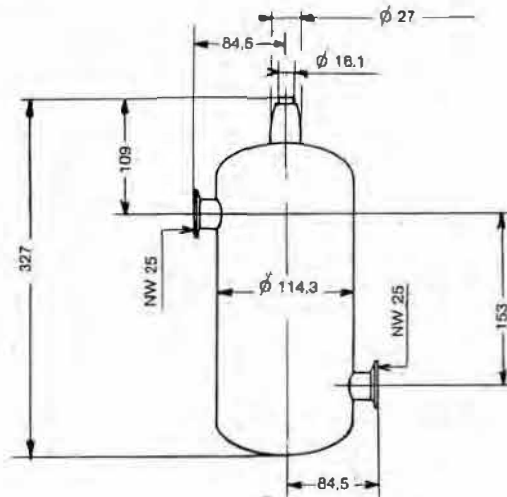

Figure 1 : Dimensions

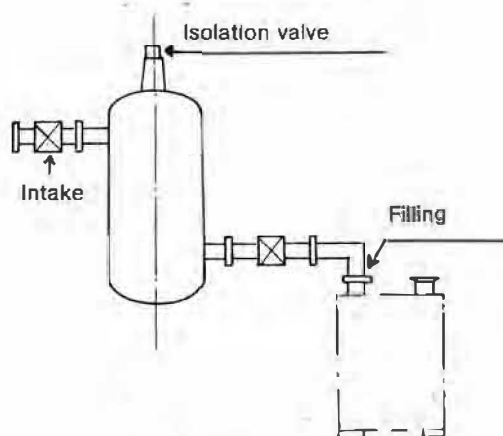

Figure 2 : Assembly

8.4 DUST FILTER NW 25 (FAP 25)

8.4.1 Description

The dust filter is installed on the intake of a pump or forepumping set handling dust or particle-laden gases (vacuum packing, metallurgy, lamp manufacture, evaporation...).

This filter collects dust particles with a diameter greater than 6 microns and thus protects the pumping system without any appreciable pressure drop.

This accessory is designed for the pumping of not very corrosive gases and is therefore not recommended for use in the micro-electronic field. When condensable vapors are pumped and also, with polymer products.

8.4.2 Characteristics

Overall dimensions : see figure 1.

Connection : NW 25 Pneurop.

Part number : 068440.

Weight : 140 g.

Material : polycarbonate body,
glass microfiber + epoxy blinder cartridge.

Filtration capacity : 15 m³/h.

Maximum service temperature : 80°C.

Connection to pump : side marked "Pump ↓".

Delivered with : 1 clamp NW 25 (P/N 083264),
1 centering ring NW 25 with Perbunan o-ring
(P/N 068189).

8.4.3 Installation

- As a general rule, the sealing arrangement and materials used for the manufacture of the accessories used upstream and downstream of the dust filter should be compatible with the gases handled and the desired safety requirements.
- The dust filter ports are equipped with Pneurop NW 25 ISO ends for quick-disconnect couplings allowing adaptation of various piping elements (see diagram 7).
- Prior to connecting the filter to the system, mark the installation direction; the "Pump ↓" side must be connected to the forepump intake (label 7).

8.4.4 Utilization - Maintenance

a) Cartridge saturation

A reduction of the pumping velocity indicates filter clogging. In this condition, the cartridge causes a pressure drop which varies according to the degree of contamination. It is then necessary to replace the cartridge and clean the filter.

b) Dismantling of dust filter (see figure 2)

CAUTION : Prior to performing any work on the filter, ensure that the pump is stopped and that the filter is subjected to the atmospheric pressure.

- Remove the connecting screws (6).
- Remove the body (1), spring (5), valve (4), clogged cartridge (3) and the O-ring (2).

c) Cleaning

- NEVER CLEAN THE CARTRIDGE : IT MUST BE SYSTEMATICALLY REPLACED BY A NEW CARTRIDGE.
- Clean the parts with a dry cloth and, if necessary, FREON 113*.
- Replace the O-ring (2) with a new seat.

* Du Pont de Nemours registered Trademark.

d) Reassembly

- Place the O-ring (2) in its groove in the lower body.
- Install the new cartridge (3) and push down until contacting the bottom of the body. Install the valve (4) with the smooth face on the cartridge side; center the spring (5) on the valve (4). Fit the upper body (1) and secure with the screws (6).

8.4.5 Spare parts

Reference	Description	Part number
3	Cartridge	068445
2	O-ring	079015

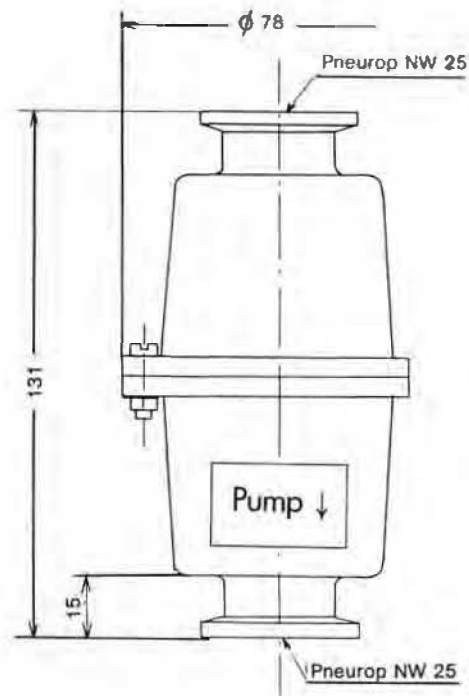

Figure 1

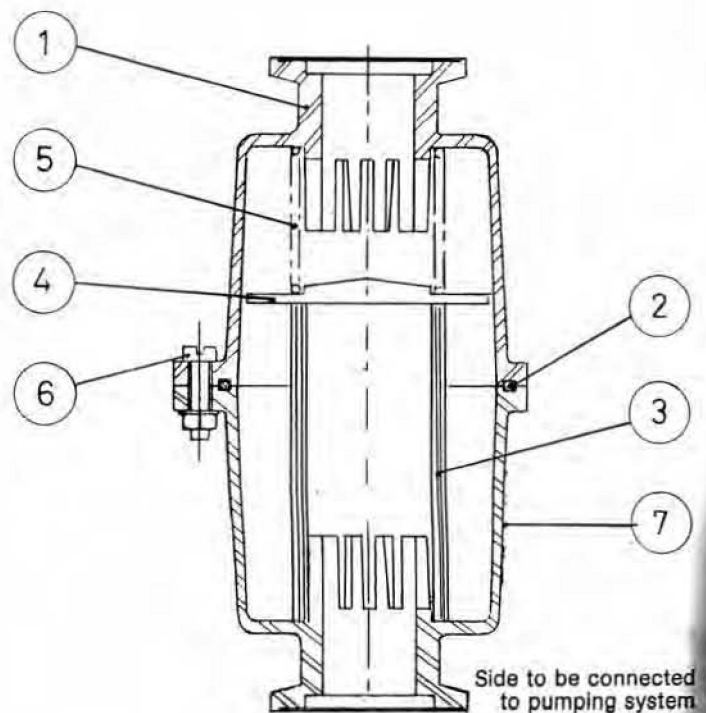
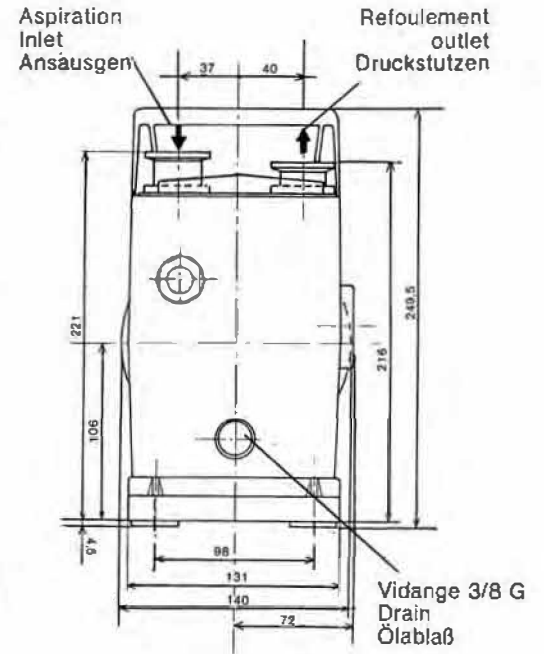
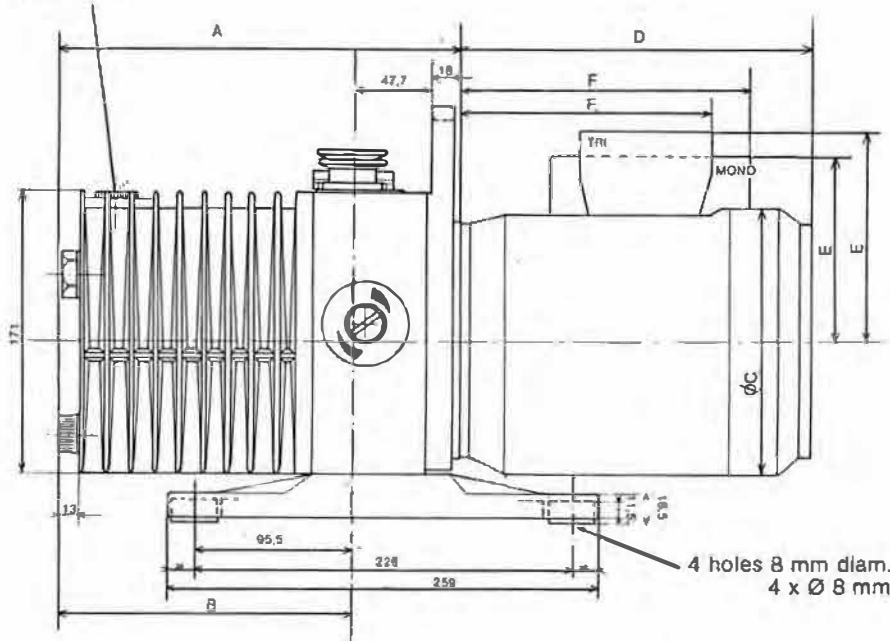

Figure 2

- Body
- O-ring
- Filter cartridge
- Safety valve
- Spring
- Fasteners
- Label

PLAN D'ENCOMBREMENTS/DIMENSIONS/ABMESSUNGEN

Remplissage 3/8 G
Fill hole
Öl einfüllen



TYPES TYP	MONOPHASE SINGLE-PHASE / WECHSELSTROM			TRIPHASE THREE-PHASE / DREHSTROM		
	1012 A - 2008 A 2012 A	2020 A	1004 A 2004 A	1012 A - 2008 A 2012 A	2020 A	1004 A 2004 A
A	282,5	310,5	240,5	282,5	310,5	240,5
B	216,5	249,5	174,5	216,5	249,5	174,5
C	163	163	163	130	143	130
D	215	215	215 Mini 200	Maxi 215 Mini 200	Maxi 235 Mini 215	Maxi 215 Mini 200
E	127	127	127	110	127	110
F	175	175	175	150	175	150

PLANCHE 1 / DIAGRAM 1 / ABBILDUNG 1

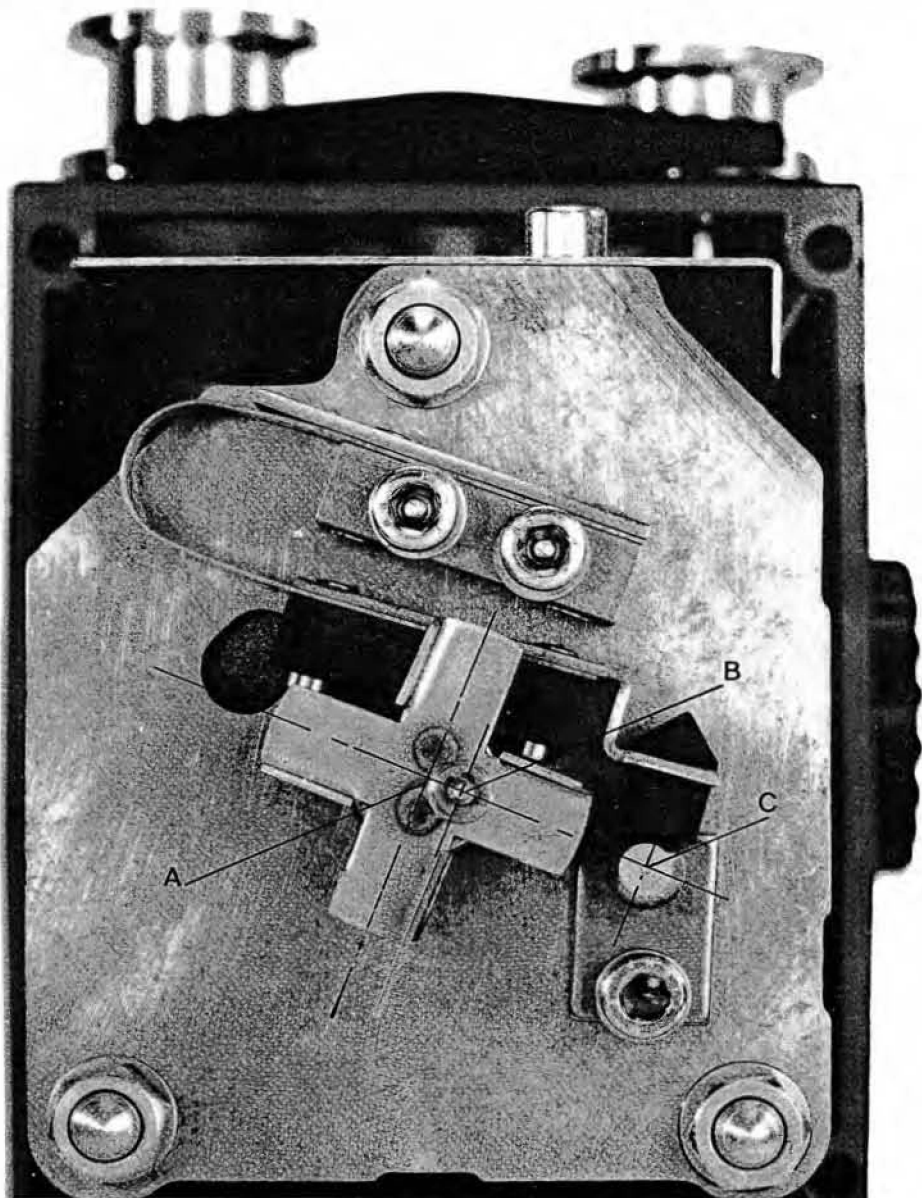

A

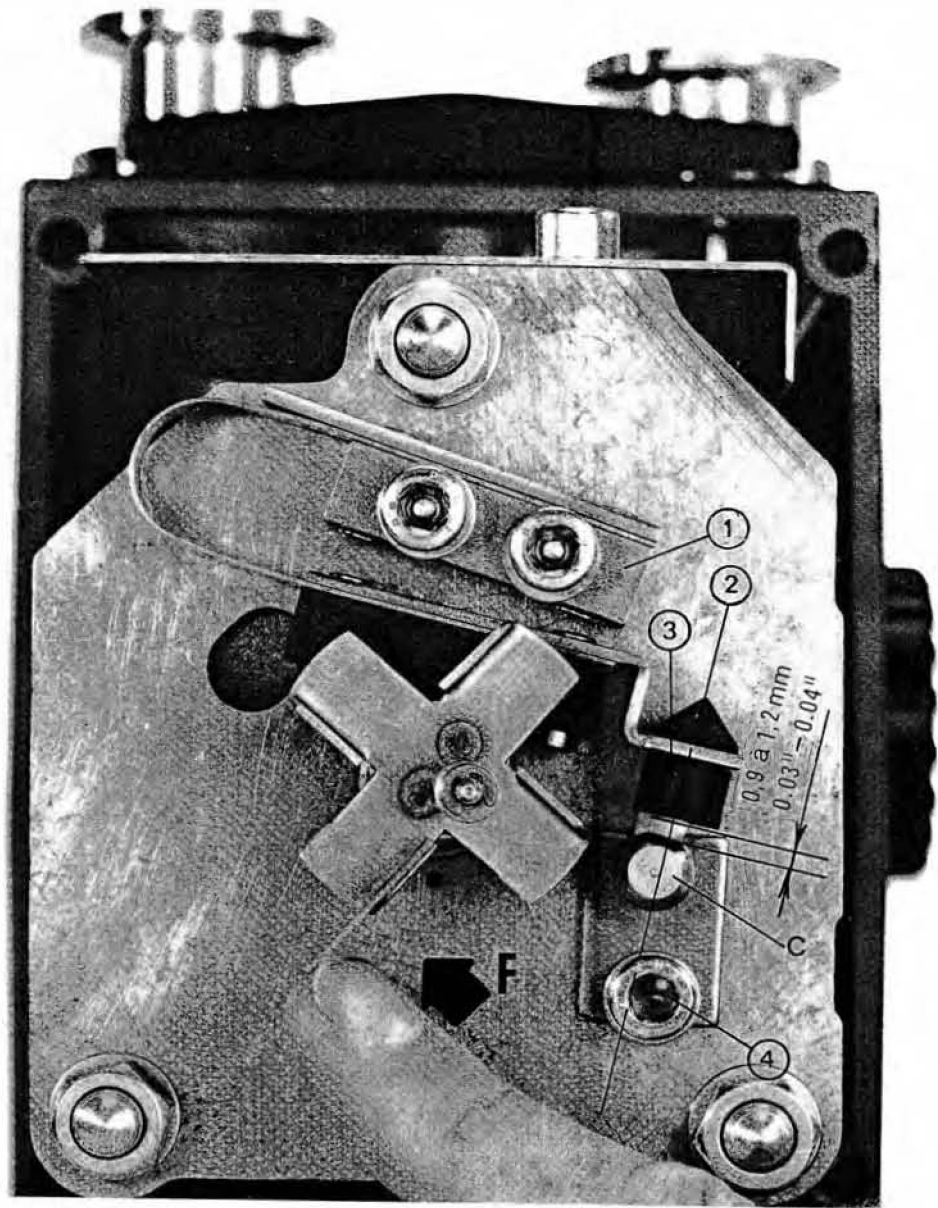

B

PLANCHE 2 : REGLAGE DU SYSTEME D'ETANCHEITE
 DIAGRAM 2 : ADJUSTMENT OF ANTISUCKBACK VALVE ASSEMBLY
 ABILDUNG 2 : JUSTIERUNG DES DICHTUNGSSYSTEMS

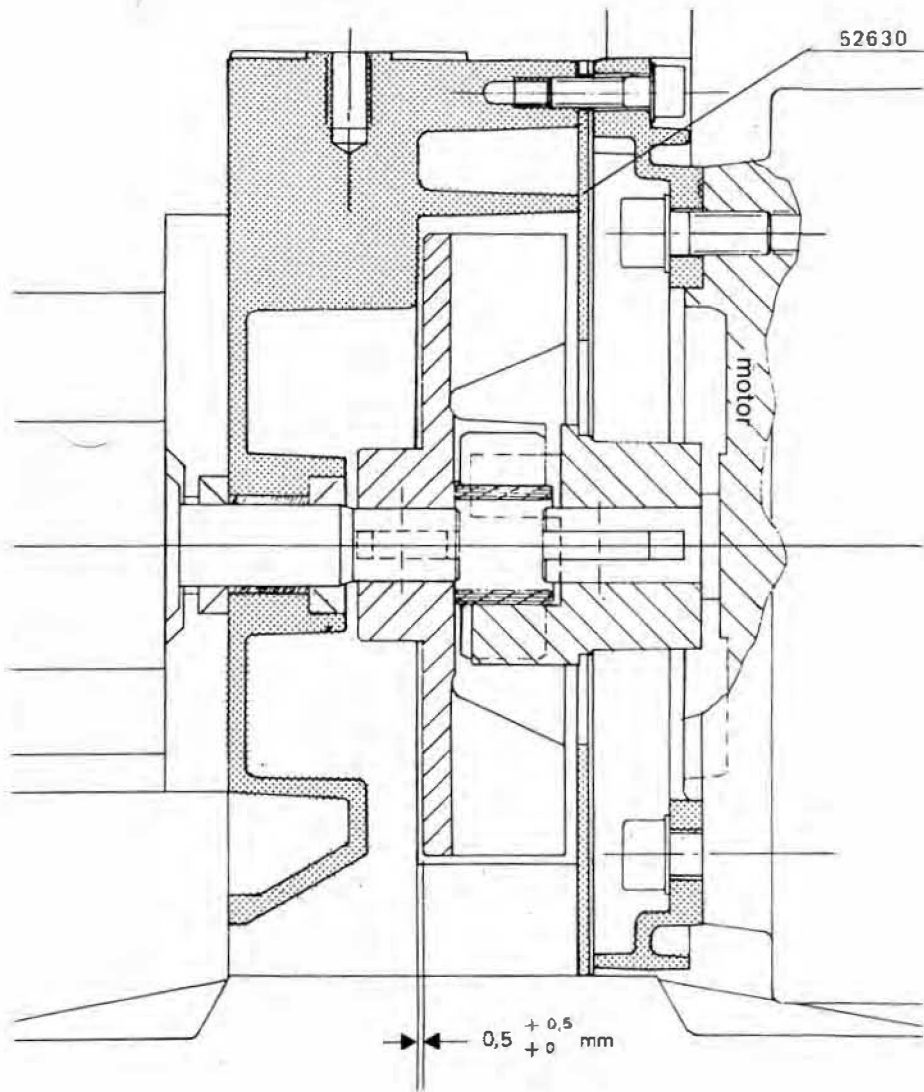

1.50 Hz (IEC Motor)

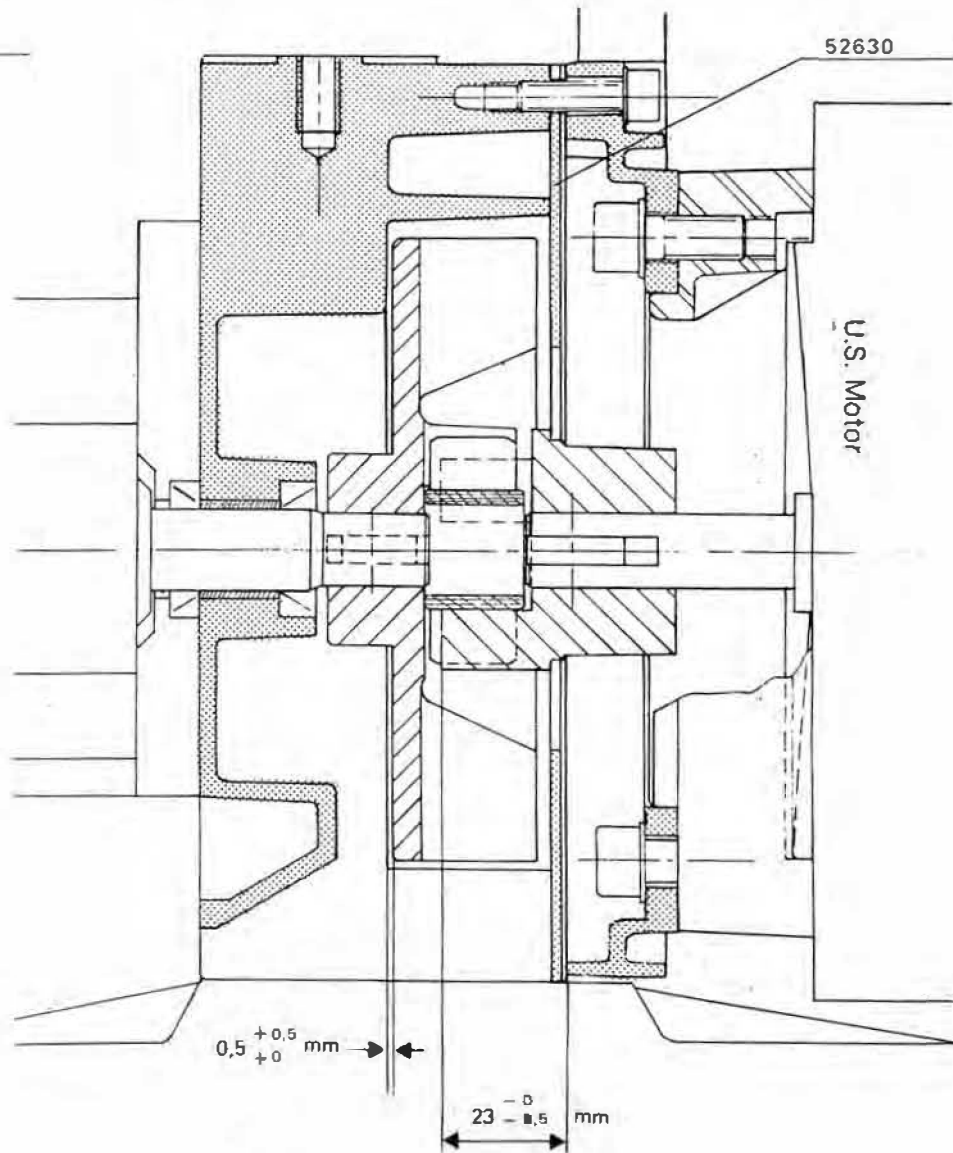

2.60 Hz (U.S. Motor)

PLANCHE 3: RÉGLAGE DE L'ACCOUPEMENT / VENTILATEUR
 DIAGRAM 3: COUPLING / FAN ADJUSTMENT
 ABBILDUNG 3: EINSTELLUNG VON KUPPLUNG UND VENTILATOR

Procédé de démontage des joints à lèvres
 Removal of lip seals
 Lippendichtungen Demontage



Manchon protecteur
 Protective sleeve
 Schutzhülse

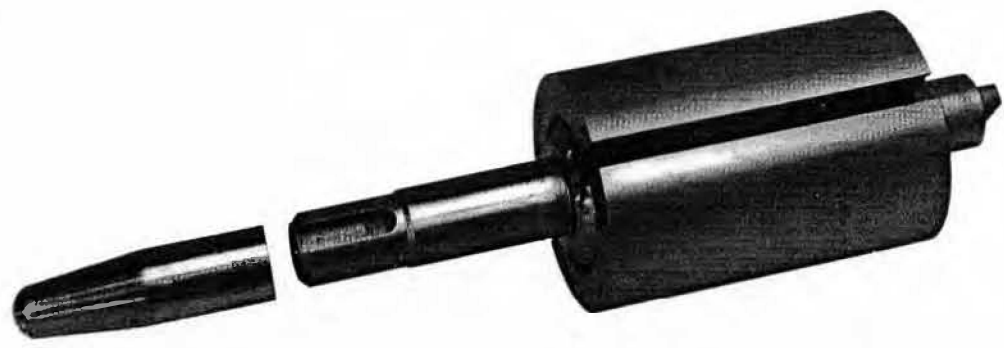

Mandrins de montage des joints à lèvres
 Tools for installing lip seals
 Montagedorn

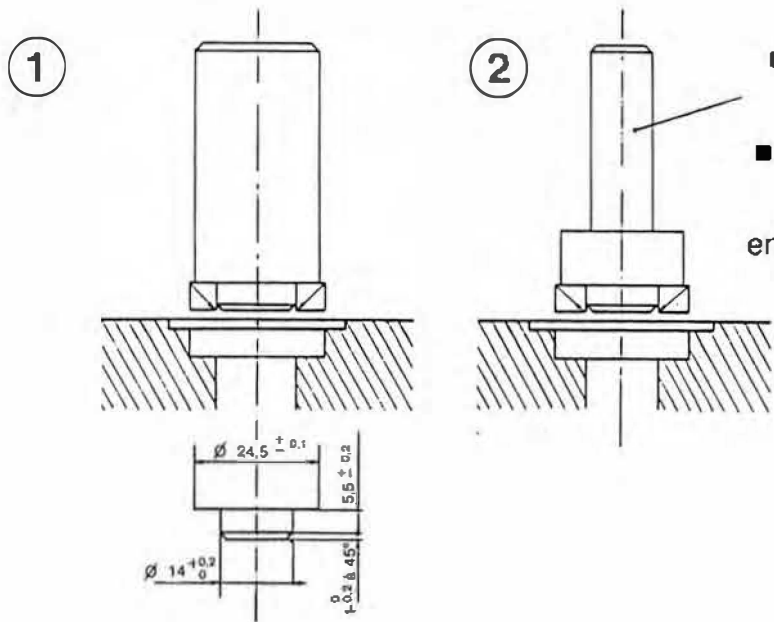

- Ø adapté au mandrin de la presse ou de la perceuse
- Diam. adapté à press or drill chuck
- Dorndurchmesser entsprechend Presse oder Bohrmaschine

PLANCHE 4 / DIAGRAM 4 / ABBILDUNG 4

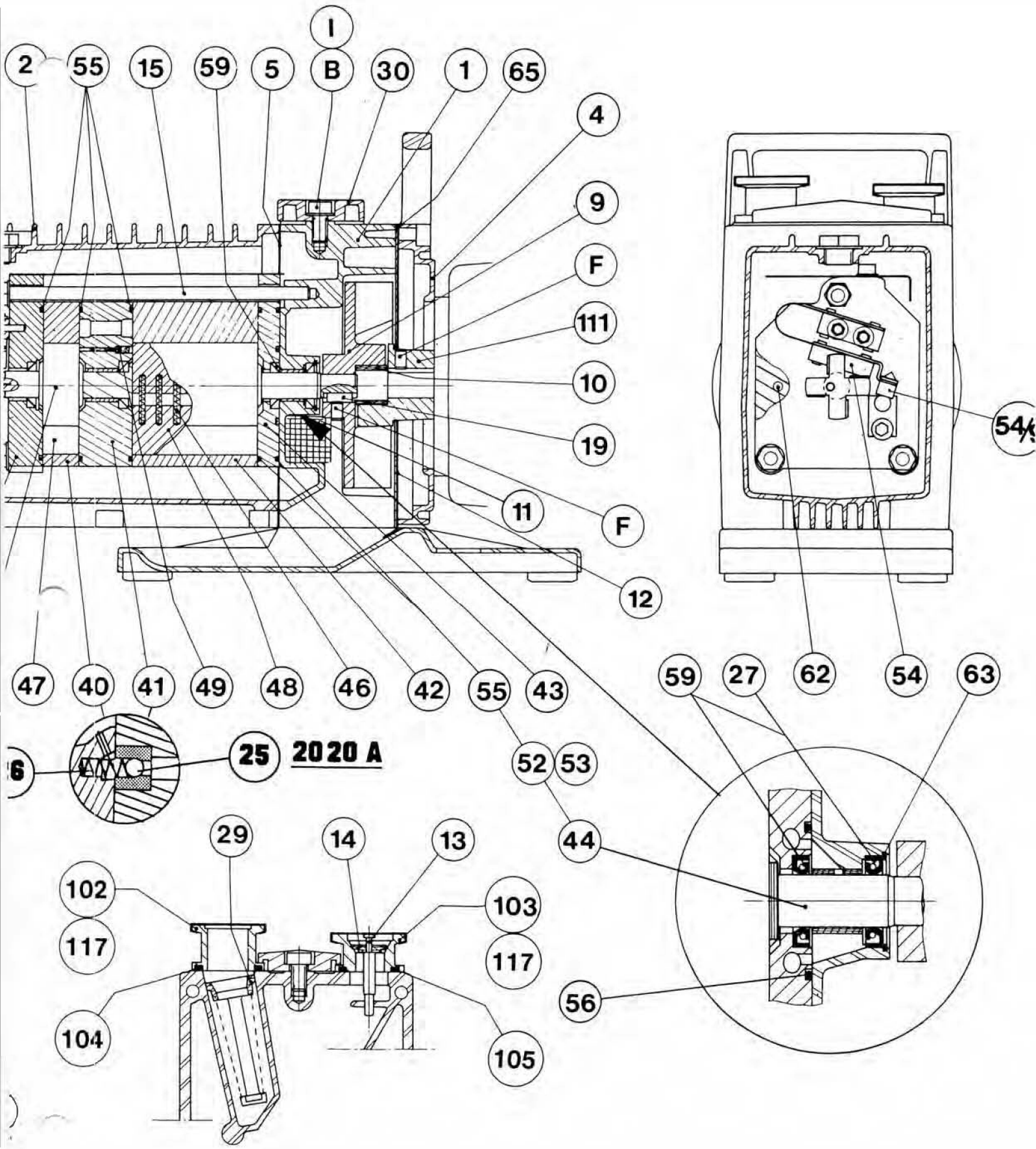

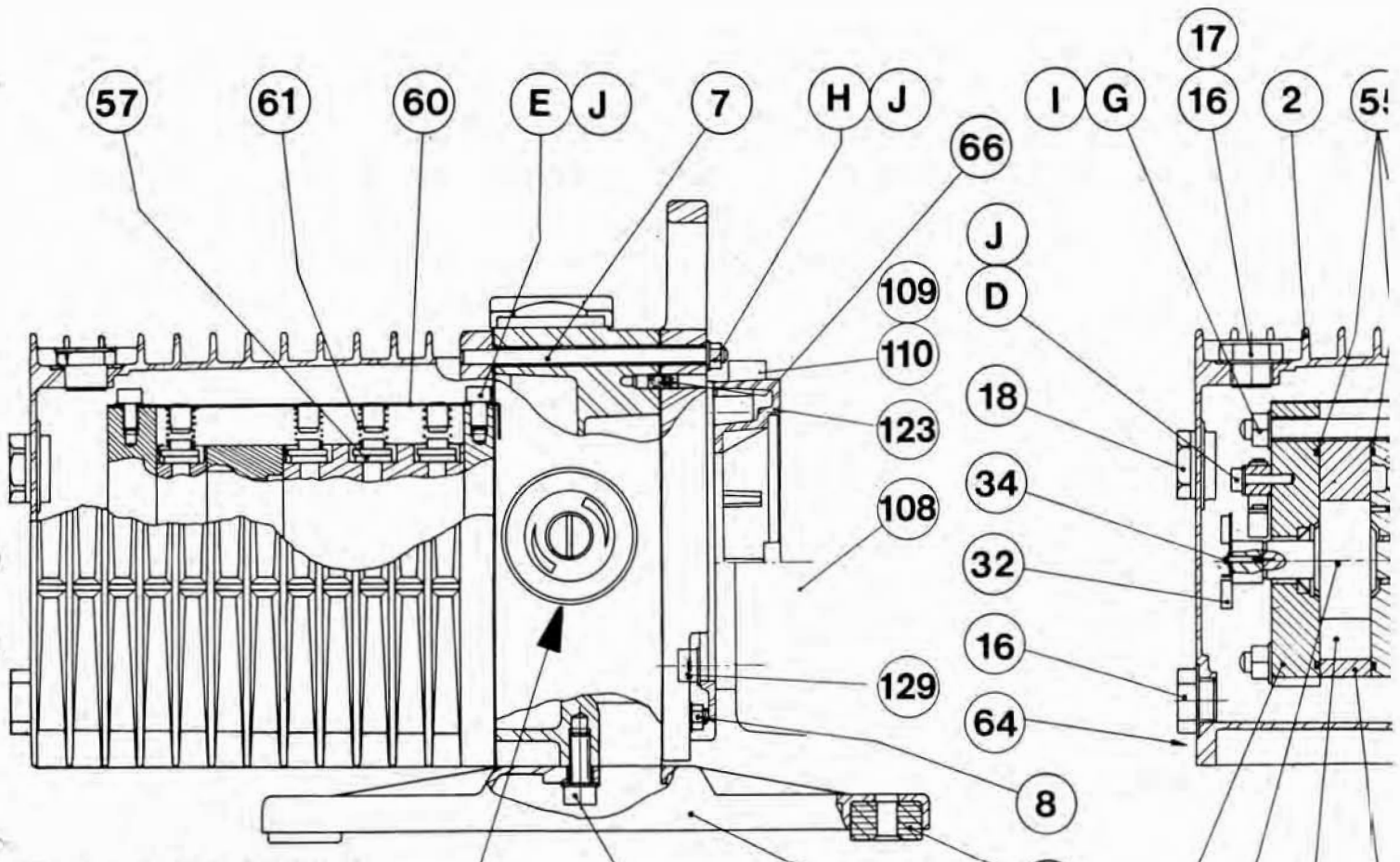

Pompes 1004 A à 2012 A
 1004 A to 2012 A pumps
 1004 A zu 2012 A Pumpen

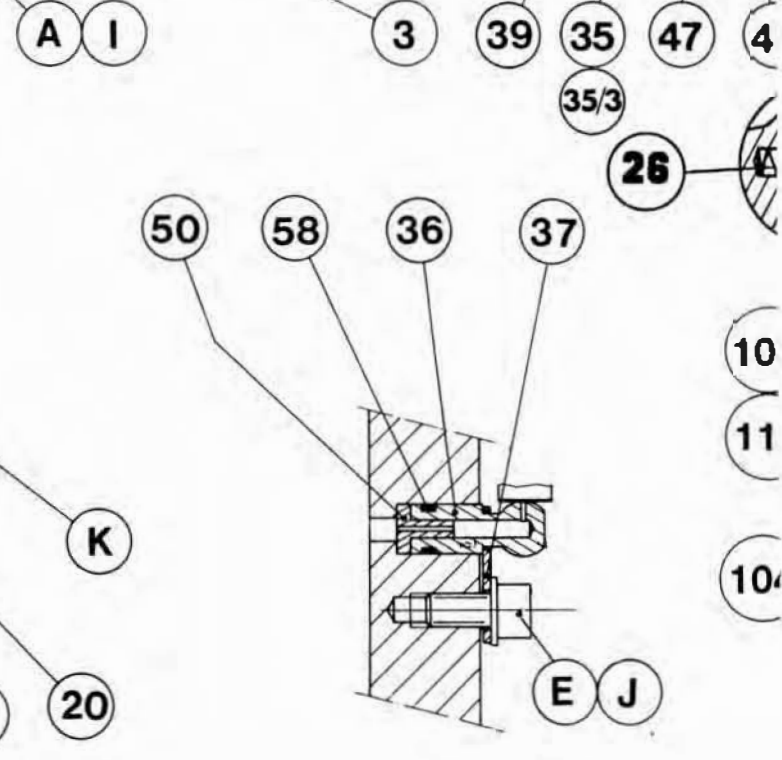
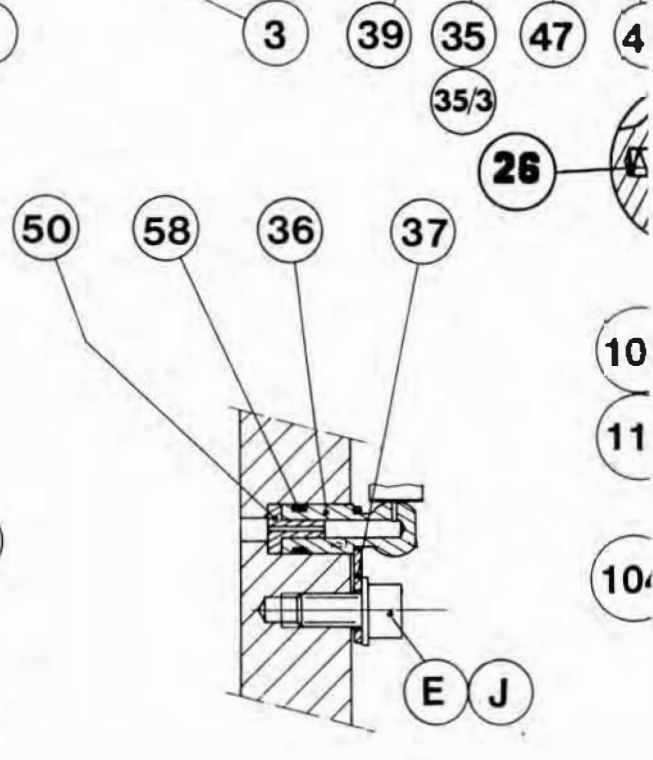
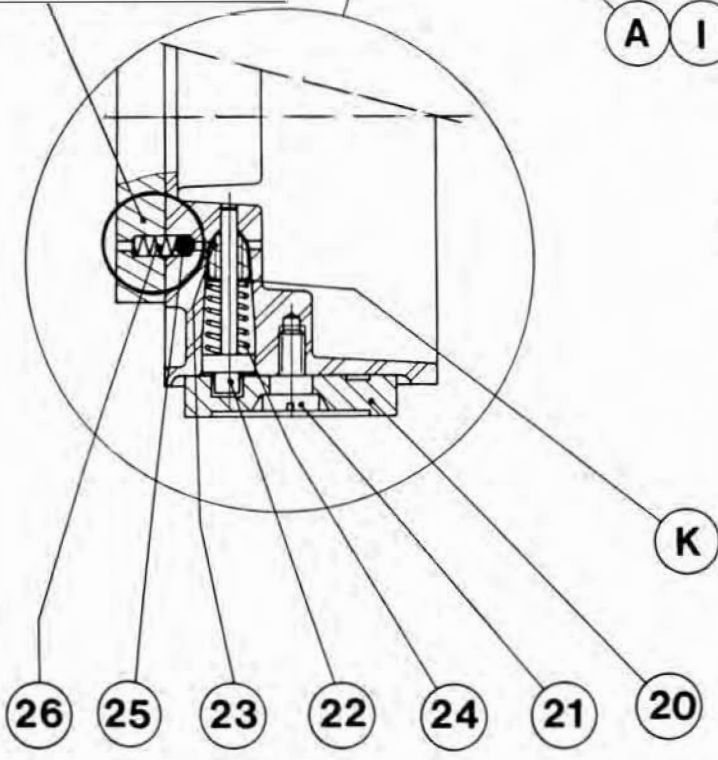

POCHETTE DE JOINTS (A) – LOT DE MAINTENANCE (A)+(B)
 MINOR MAINTENANCE (A) – MAJOR MAINTENANCE (A)+(B)
 ERSATZDICHTUNGEN (A) – WARTUNGSMATERIAL (A)+(B)

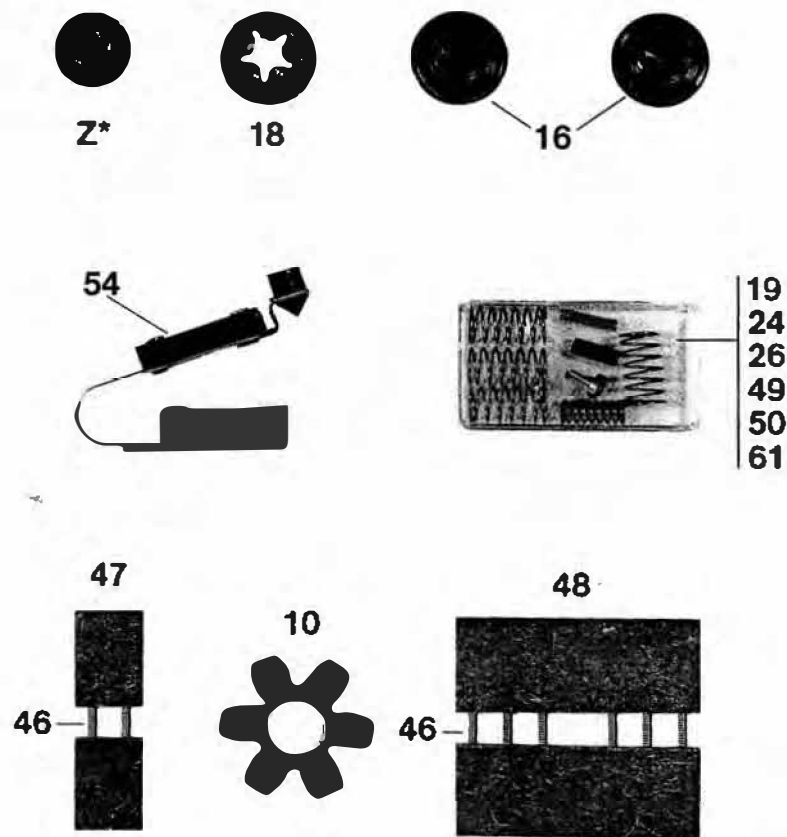
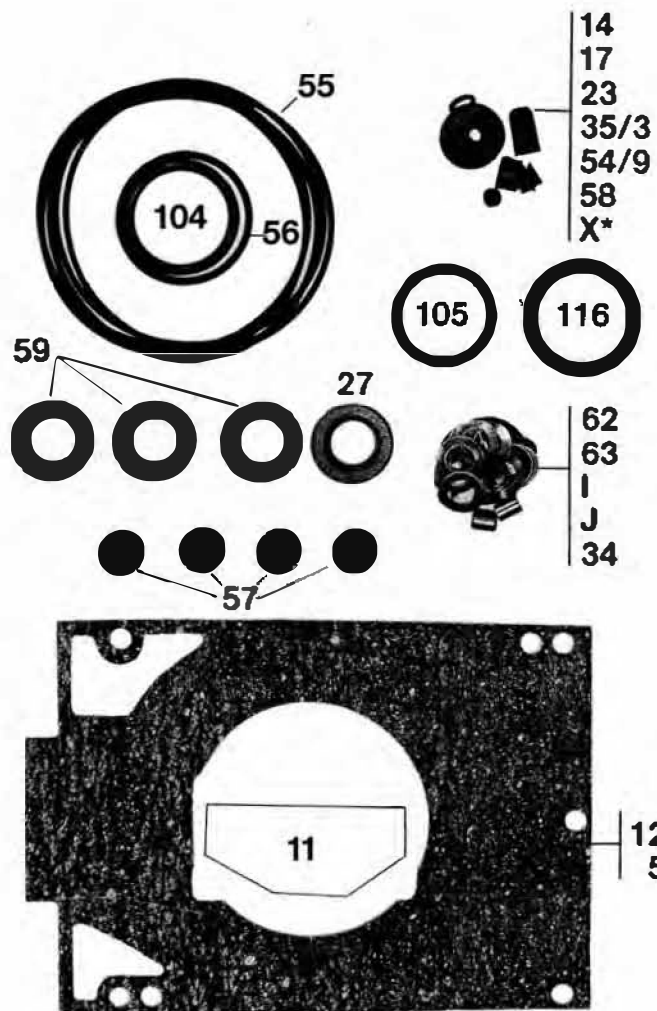

* Pompes ayant un numéro de série < 50000. Pumps with serial number before 50000. Pumpen mit Seriennummer vor 50000.
 (Z) Bouchon G 1/4 / Plug G 1/4 / Blindstopf / (X) Clapet / Valve plate / Ventilteller

TABLEAU DE SÉLECTION DES POMPES ET ACCESSOIRES EN FONCTION DE L'APPLICATION PUMPEN UND ZUBEHÖR NACH ANWENDUNGSBEREICH	POMPES PUMPEN			HUILES ÖL	ACCESSOIRES ZUBEHÖR										TABLE OF PUMPS AND ACCESSORIES RECOMMENDED FOR DIFFERENT APPLICATIONS		
	Standard	Chimiste - Chemie	Hermétique - Hermetik	CP ... plus CPH ... plus	Minérale - Mineral öl	ALCATEL 113 (PTFE)	Séparateur de brouillard Dreibeckschleier	Piège à sorption	Piège à azote liquide Flüssig-Stickstoff-Falle	Filtre à huile (O)	Offliner (O)	Filtre à huile (DE)	Offliner (DE)	Let d'air automatique Automatischer Gasballast		Purge d'azote Neutral gasreinigung	Condenseur Kondensator
Cryogénie Kryotechnik	○		×	×		×	○	○									Cryogenics
Récupération de gaz précieux Rückgewinnung teurerer Gase	○		×	○	○	×	×						▲				Noble gas recovery
Pompage de l'oxygène Pumpen von Sauerstoff	×			×	▲	×	○	▲									Oxygen pumping
Séchage Trocknung	×				×		◇	⊖	⊖				×		×	⊖	Drying
Lyophilisation alimentaire Gefriertrocknung	×				×		◇						×			⊖	Freeze drying, food
Lyophilisation biologique Biolog. Gefriertrocknung	⊖			×	×	○	◇		⊖	⊖	⊖	×					Freeze drying, biology
Dépôt en phase gazeuse (CVD) + LPCVD Beschichten in Gasphase + LPCVD		×		○	×	○	◇		▲	×		○	×			○	CVD + LPCVD
Implantations d'ions Ionimplantation		×			×	○	○				×						Ion implantation
Gravure sèche Trockenätzung	◇	⊖	◇	×	⊖	×	⊖	○	○	⊖	×	⊖	×				Dry etching
Evaporation sous vide Vakuumverdampfung	×				×		○	○	○	◇						⊖	Vacuum evaporation
Pulvérisation cathodique Katodenzersäuberung	×			○	×	⊖	×				⊖	⊖					Cathode sputtering
Epitaxie Epitaxie	×	○			×		×	×									Epitaxy
Imprégnation sous vide Vakuumimprägnierung	×				×		⊖	○		◇		⊖	×			◇	Vacuum impregnation
Industrie frigorifique Kühlindustrie	×				×		×		⊖			⊖					Refrigeration industry
Fabrication de lampes Lampenfabrikation	×		○		×	○	×		⊖		⊖					○	Bulb manufacture
Pompage de tube cathodique Evakuierung von Katodenstrahlröhren	×				×		×	⊖								⊖	Cathode tube pumping
Distillation moléculaire Molekulardestillation	×	◇		○	○	⊖	⊖		⊖			○					Molecular distillation
Emballage sous vide Vakuumverpackung	×				×		×	×	○								Vacuum packaging
Contrôle d'étanchéité Lecksuche	×				×		×		○			○					Leak detection
× Conseillé - Empfohlen ○ Possible - Möglich ⊖ Sous réserve - Vorbehallich ◇ Non recommandé - Nicht empfohlen ▲ Dangereux - Gefährlich	Standard	Chemical	Hermetic	CP ... plus CPH ... plus	Mineral	Alcatel 113 (PTFE)	Oil mist eliminator	Sorption trap	Liquid nitrogen trap	Oil filtration (O filter)	Oil neutralization (DE filter)	Remote controlled gas ballast	Neutral Gas supply	Condenser	Dust filters		× Recommended ○ Possible ⊖ Possible with limitation ◇ Not recommended ▲ Dangerous
	PUMP			OIL		ACCESSORY											

ALCATEL vous fera profiter de son expérience en vous conseillant à la fois sur le choix de la pompe et sur celui des accessoires répondant au mieux à votre application.

ALCATEL steht Ihnen zur Beratung beim Kauf von Pumpen und Zubehör mit seiner Erfahrung zur Verfügung.

ALCATEL'S experience may assist you in proper selection of pumps and accessories best suited for your application.

ACCESSOIRES DE RACCORDEMENT ET ELEMENTS DE CANALISATION	CONNECTINGS ACCESSORIES AND VACUUM FITTINGS	ANSCHLUSSFLANSCHEN UND VERBINDUNGSELEMENTS	RACCORDEMENT DN 25 Ref. NW 25 CONNECTION P/N NW 25 FLANSCH Best Nr.	
			Pompes standards Standard pumps Standard-Pumpen	Pompes chimistes Chemical pumps Chemie-Pumpen
Anneaux de centrage - inox/Perbunan - inox/Viton	Centering rings - stainless steel/Buna - stainless steel/Viton	Zentrierringe - Edelstahl/Perbunan - Edelstahl/Viton	068189	068229
Colliers de serrage	Quick connect clamp	Spannringe	083264	083264
Tuyaux plastique armé longueur 1 m	Reinforced plastic hoses 1 m length	Plastikschläuche Länge 1 m	068271	
Tuyaux flexibles inox longueur 0,5 m longueur 1 m	Flexible stainless steel hoses 0,5 m length 1 m length	Edelstahl-Wellschläuche Länge 0,5 m Länge 1 m		068371 068372
Embouts lisse - Macrovac - Inox.	Long nipples - Macrovac - stainless steel	Anschweissflansche - PVC - Edelstahl	068591	068237
Coudes égaux - Macrovac - Inox.	Symmetrical elbows - Macrovac - stainless steel	Winkelstücke 90° - PVC - Edelstahl	068581	068536
Tès égaux - Macrovac - Inox.	Symmetrical tees - Macrovac - stainless steel	T - Stücke - PVC - Edelstahl	068582	068563
Obturbateurs - Macrovac - Inox.	Blank-off flanges - Macrovac - stainless steel	Blindflansche - PVC - Edelstahl	068594	068196

PLANCHE 7 / DIAGRAM 7 / ABBILDUNG 7

PIECES DE RECHANGE POUR :
ERSATZTEILLISTE FÜR :
SPARE PARTS LIST FOR : 1004 A - 2004 A - 2008 A - 1012 A - 2012 A - 2020 A

REP.	DESIGNATION	BENENNUNG	SPECIFICATION	TYPES						REF. Bestell. Nr P/N :	Poch. Joints Dichtungs. Minor maint.	Lot maint. Ersatzteils. Major maint.
				2020 A	2012 A	1012 A	2008 A	2004 A	1004 A			
VERSION US - US VERSION - AMERIKANISCHE AUSFÜHRUNG												
102	Embout d'aspiration NW 25	Ansaugstutzen NW 25	Inlet port NW 25	1	1	1	1	1	1	052594		
103	Embout de refoulement NW 25	Auspuffstutzen NW 25	Exhaust port NW 25	1	1	1	1	1	1	052595		
104	Joint C 3,6-D 29,3	Dichtung C 3,6-D 29,3	O-ring C 3,6-D 29,3	1	1	1	1	1	1	082122	x	
105	Joint C 3,6-D 26,2	Dichtung C 3,6-D 26,2	O-ring C 3,6-D 26,2	1	1	1	1	1	1	082120	x	
108	Moteur mono. 115/230 V 60 Hz-1800 tr/mn-	Wechselstrommotor 115/230 V 60 Hz-1800 tr/mn-	Single phase motor 115/230 V 60 Hz-1800 rpm-	1	1	1	1	1	1	voir catalogue US see us catalog siehe USA Katalog		
108	Moteur tri. 230/460 V - 60 Hz - 1800 tr/mn	Drehstrommotor 230/460 V - 60 Hz - 1800 tr/mn	Three phase motor 230/460 V - 60 Hz - 1800 rpm	1	1	1	1	1	1			
111	1/2 Manchon moteur	Küplungshälfte	Motor coupling	1	1	1	1	1	1	052684		
117	Protecteur	Schutzkappe	Protector	2	2	2	2	2	2	068000		
123	Flasque d'adaptation	Flansch	Plate	1	1	1	1	1	1	052589		
124	Embout d'adaptateur	Stützen	Nipple conection	2	2	2	2	2	2	052652		
125	Anneau de centrage NW 25	Zentrierringe	Centering ring	2	2	2	2	2	2	068189		
126	Collier de serrage	Spanning	Quick connect clamp	2	2	2	2	2	2	083264		
129	Vis Hc - M 6 x 10	Schraube Hc - M 6 x 10	Screw Hc - M 6 x 10	1	1	1	1	1	1	075034		
VERSION JAPON - JAPANESE VERSION - JAPANISCHE AUSFÜHRUNG												
102	Embout d'aspiration NW 25	Ansaugstutzen NW 25	Inlet port NW 25	1	1	1	1	1	1	052594		
103	Embout de refoulement NW 25	Auspuffstutzen NW 25	Exhaust port NW 25	1	1	1	1	1	1	052754		
104	Joint C 3,6-D 29,3	Dichtung C 3,6-D 29,3	O-ring C 3,6-D 29,3	1	1	1	1	1	1	082122	x	
105	Joint C 3,6-D 26,2	Dichtung C 3,6-D 26,2	O-ring C 3,6-D 26,2	1	1	1	1	1	1	082120	x	
108	Moteur	Motor	Motor							voir catalogue see catalog siehe Katalog		
111	1/2 Manchon moteur	Küplungshälfte	Motor coupling	1	1	1	1	1	1	052554		
117	Protecteur	Schutzkappe	Protector	2	2	2	2	2	2	068000		
116	Joint torique C 5-D 28	Dichtung C 5-D 28	O-ring C 5-D 28	1						079238	x	
124	Embout d'adaptateur	Stützen	Nipple conection	2	2	2	2	2	2	052652		
125	Anneau de centrage NW 25	Zentrierringe	Centering ring	2	2	2	2	2	2	068189		
126	Collier de serrage	Spanning	Quick connect clamp	2	2	2	2	2	2	083264		
129	Vis Hc - M 6 x 10	Schraube Hc - M 6 x 10	Screw Hc - M 6 x 10	1	1	1	1	1	1	075034		