

Instruction Manual

EH Mechanical Booster Pumps



For safe area applications



FOR SALES AND SERVICE PLEASE CALL:

PTB SALES T :: 626.334.0500
service@ptbsales.com
www.ptbsales.com

DATE SERVICED: _____

VIEW OUR INVENTORY



WWW.EDWARDSVACUUM.COM



Declaration of Conformity

We, Edwards Limited,
Crawley Business Quarter,
Manor Royal,
Crawley,
West Sussex, RH10 9LW, UK

declare under our sole responsibility, as manufacturer and person within the EU authorised to assemble the technical file, that the product(s)

EH250	A30105945	A30106946	A30105934	A30106934
EH500	A30205945	A30206946	A30205934	A30206934
EH1200	A30505945	A30506946	A30505934	A30506934
EH2600	A30705945	A30706946	A30705934	A30706934
EH4200	A30905945	A30906946	A30905934	A30906934
EH250FX	A30107945	A30108946	A30107934	A30108934
EH500FX	A30207945	A30208946	A30207934	A30208934
EH1200FX	A30507945	A30508946	A30507934	A30508934
EH2600FX	A30707945	A30708946	A30707934	A30708934
EH4200FX	A30907945	A30908946	A30907934	A30908934

to which this declaration relates is in conformity with the following standard(s) or other normative document(s)

EN1012-2:1996+A1:2009	Compressors and Vacuum Pumps. Safety Requirements. Vacuum Pumps
EN60034-1:2010	Rotating electrical machines. Rating and performance
EN60034-30-1:2014	Rotating Electrical Machines. Efficiency classes of line operated AC motors (IE code)
EN50581:2012	Technical Documentation for the Assessment of Electrical and Electronic Products with respect to the Restriction of Hazardous Substances

and fulfils all the relevant provisions of

2006/42/EC	Machinery Directive
2014/35/EU	Low Voltage Directive
2011/65/EU	Restriction of Certain Hazardous Substances (RoHS) Directive
2009/125/EC	Ecodesign Directive, following the requirements of Regulation (EC) No. 640/2009 (as amended)

Note: This declaration covers all product serial numbers from the date this Declaration was signed onwards.

Mr Peter Meares
Senior Technical Support Manager, General Vacuum

16.06.2015, Burgess Hill

Date and Place

This product has been manufactured using the Edwards quality management system

Contents

Section	Page
1	Introduction 1
1.1	Scope and definitions 1
1.2	Description 1
1.2.1	Overview 1
1.2.2	General construction 4
1.2.3	Principle of operation 4
1.2.4	Hydrokinetic drive 4
1.3	Chemical & ATEX pumps 4
2	Technical Data 5
2.1	Operating and storage conditions 5
2.2	Performance 5
2.3	Recommended primary (backing) pumps 6
2.4	Mechanical data 6
2.5	Electrical data 7
2.6	Lubrication data 7
2.7	Hydrokinetic drive/gearbox nitrogen supply 7
2.8	Cooling water data 8
2.9	Noise and vibration data 8
2.10	Connections 8
2.11	Materials of construction of components exposed to pumped gases 9
2.12	Azide compatibility 9
2.13	Item Numbers 9
3	Installation 15
3.1	Safety 15
3.2	System requirements 15
3.3	Unpack and inspect 16
3.4	Fill the pump with oil 17
3.4.1	Hydrokinetic drive/gearbox 17
3.4.2	Shaft seal reservoir 17
3.4.3	Gear cover (all EH1200, EH2600 and EH4200 model pumps only) 18
3.5	Cooling water connections (all EH1200, EH2600 and EH4200 pumps only) 19
3.6	Electrical connections 19
3.6.1	Electrical supply configuration 19
3.6.2	Motor connections 19
3.7	Check the direction of pump rotation 20
3.8	Connect the pump inlet and outlet 21
3.9	External evacuation of hydrokinetic drive/gearbox (optional) 22
4	Operation 23
4.1	Operational safety 23
4.2	Start-up procedure 23
4.2.1	Pre-start checks 23
4.2.2	Start-up 23
4.3	Shutdown 24
5	Maintenance 25
5.1	Safety information 25
5.2	Maintenance plan 26

gp/0248/10/14

5.3	Check the oil levels	26
5.4	Inspect the pump connections	26
5.5	Change the pump oil	27
5.6	Lubricate the rear bearing (All EH250FX and EH500FX model pumps only)	28
5.7	Overhaul the pump	29
6	Storage and Disposal	31
6.1	Storage	31
6.2	Disposal	31
7	Service and Spares	33
7.1	Introduction	33
7.2	Service	33
7.3	Spares	33

For return of equipment, complete the HS Forms at the end of this manual.

Illustrations

Figure		Page
1	All EH250FX and EH500FX pump variants	2
2	All EH1200FX, EH2600 and EH4200 pump variants	3
3	EH250/EH250FX dimensions (mm)	10
4	EH500/EH500FX dimensions (mm)	11
5	EH1200/EH1200FX dimensions (mm)	12
6	EH2600/EH2600FX dimensions (mm)	13
7	EH4200/EH4200FX dimensions (mm)	14
8	Sight glasses	18
9	Flange loading limits	22
10	Lubricate the rear bearing (EH250FX, EH500 and EH500FX pumps only)	29

Tables

Table	Page
1	Operating and storage conditions 5
2	Performance data 5
3	Recommended primary (backing) pumps 6
4	Mechanical data 6
5	Electrical data 7
6	Lubrication data 7
7	Hydrokinetic drive/gearbox purge nitrogen supply data 7
8	Cooling water supply data: EH pumps 8
9	Noise and vibration data 8
10	Connections 8
11	Materials of construction 9
12	Item numbers 9
13	Motor cable gland hole sizes 20
14	Maintenance plan 25
15	Spare item numbers 33
16	EH250FX and EH500FX spare parts 33
17	EH1200 spare parts 34
18	EH2600 and EH4200 spare parts 34

Associated publications

Publication title	Publication number
Vacuum Pump and Vacuum Systems Safety Manual	P400-40-100

This page has been intentionally left blank.

1 Introduction

1.1 Scope and definitions

This manual provides installation, operation and maintenance instructions for Edwards EH mechanical booster pumps listed below. The pumps must be used as specified in this manual. Read this manual before installing and operating the pumps.

- PFPE pumps:
EH250FX, EH500FX, EH1200FX, EH2600FX and EH4200FX
- Hydrocarbon pumps:
EH250, EH500, EH1200, EH2600 and EH4200

Important safety information is highlighted as WARNING and CAUTION instructions; these instructions must be obeyed. The use of WARNINGS and CAUTIONS is defined below.



WARNING

Warnings are given where failure to observe the instruction could result in injury or death to people.

CAUTION

Cautions are given where failure to observe the instruction could result in damage to the equipment, associated equipment and process.

The units used throughout this manual conform to the SI international system of units of measurement.

1.2 Description

1.2.1 Overview

The EH pumps are compact and have high pumping speeds. The EH pumps must be used with a suitable backing pump delivering at least 1/10th of volumetric capacity of the booster pump. The EH pumps can operate with a maximum continuous inlet pressure of 1000 mbar. Lower system pressures can be achieved by the use of two or more EH pumps in series.

On all EH pumps, the hydrokinetic drive/gearbox is connected to the pump outlet by a pressure equalisation passageway and forms an integral part of the vacuum system. The connecting passageway has a filter which removes debris and so prevents contamination of the lubricating oil and bearings. For an even cleaner system, evacuate the end cover/gear cover by connecting the evacuation port (Figure 1, item 5 or Figure 2, item 6) to the pump inlet or to an external vacuum pump.

The hydrocarbon EH pumps use hydrocarbon oils, such as Edwards Ultragrade 20. Versions of the EH pumps for use with PFPE (perfluoropolyether) oils are also available for vacuum systems in which enriched oxygen or other reactive or corrosive gases are pumped. The EH pumps must **not** be used to pump peroxides.

All of the EH2600 and EH4200 model pumps have an after-cooler in the pump outlet, to reduce the exhaust gas and rotor temperature.

The EH pumps are safe to handle non-flammable gases and vapours within the normal operating parameters of the pumps, as defined in this manual.

All EH pumps have ISO inlet flange and outlet flange connections.

Figure 1 - All EH250FX and EH500FX pump variants

AW7031/A

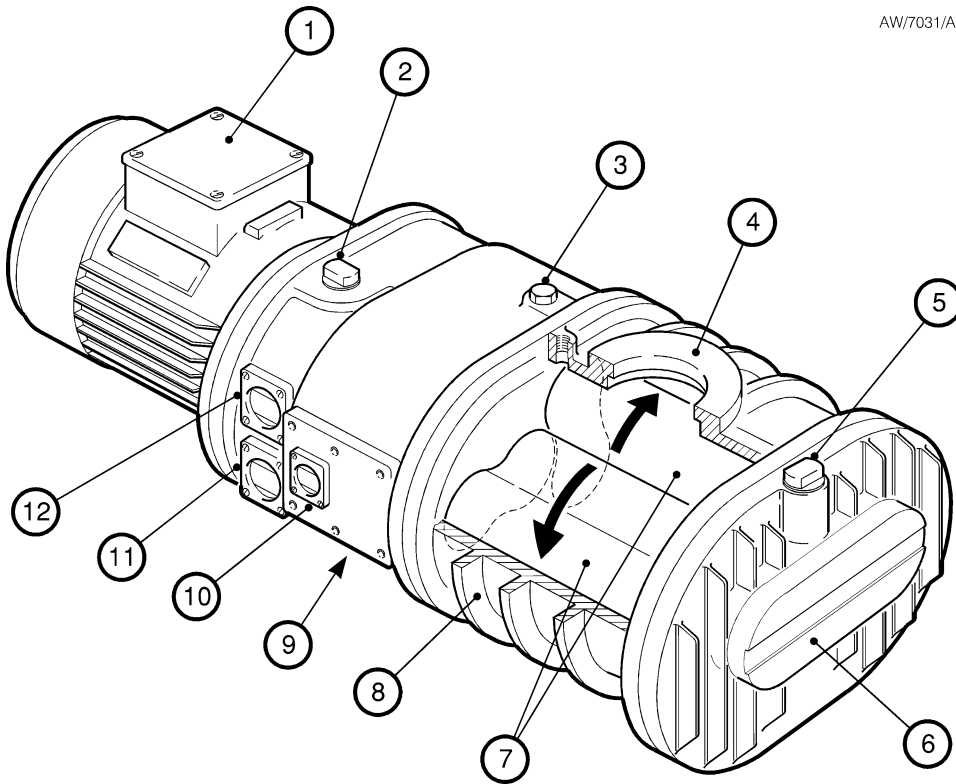

1. Terminal box
2. Shaft seal reservoir vented oil filler plug
3. Hydrokinetic drive/gearbox oil filler plug
4. Inlet flange
5. External evacuation point
6. End cover
7. Rotors
8. Stator housing
9. Hydrokinetic drive/gearbox oil drain plug (under the pump)
10. Direction of rotation sight glass
11. Oil level sight glass (hydrokinetic drive/gearbox)
12. Oil level sight glass (shaft seal reservoir)

Figure 2 - All EH1200FX, EH2600 and EH4200 pump variants

AW/5857/B

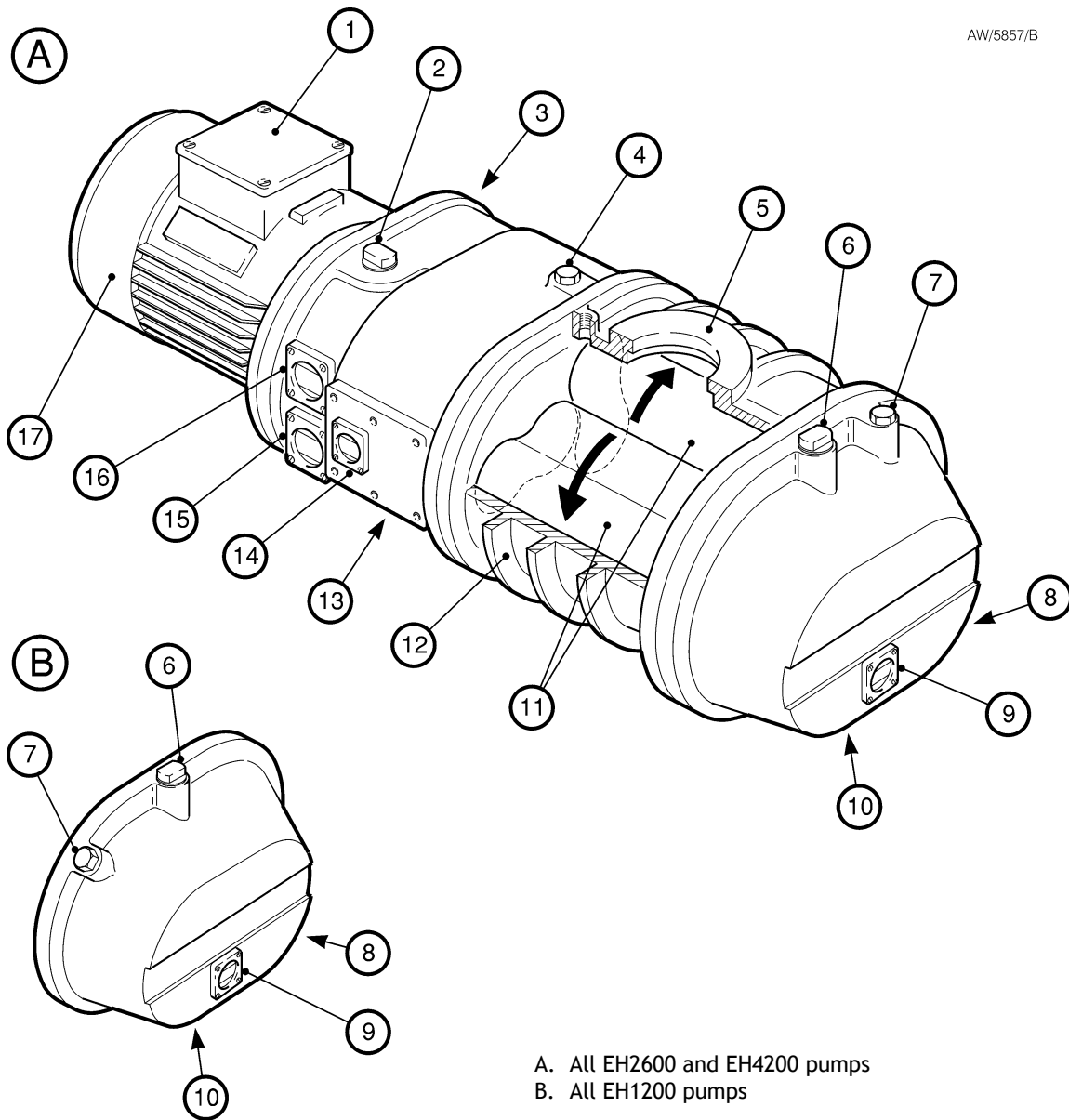

A. All EH2600 and EH4200 pumps
 B. All EH1200 pumps

- | | |
|-----------------------------------------------------------------------------------------------------------------------------------------------------------------------------------------------------------------------------------------------------------------------------------------------------------------------------------------------------------------------------------------------------------------------------------------------------------------------------------------------|----------------------------------------------------------------------------------------------------------------------------------------------------------------------------------------------------------------------------------------------------------------------------------------------------------------------------------------------------------------------------------|
| <ul style="list-style-type: none"> 1. Terminal box 2. Shaft seal reservoir vented oil filler plug 3. Cooling water connection 4. Hydrokinetic drive/gearbox oil filler plug * 5. Inlet flange 6. External evacuation point 7. Gear cover oil filler plug 8. Cooling water connection 9. Oil level sight glass (gear cover) 10. Gear cover oil drain plug (under the pump) 11. Rotors | <ul style="list-style-type: none"> 12. Stator housing 13. Hydrokinetic drive/gearbox oil drain plug (under the pump) 14. Direction of rotation sight glass † 15. Oil level sight glass (hydrokinetic drive/gearbox) 16. Oil level sight glass (shaft seal reservoir) 17. Motor fan cover <p>† EH1200 pumps only.</p> |
|-----------------------------------------------------------------------------------------------------------------------------------------------------------------------------------------------------------------------------------------------------------------------------------------------------------------------------------------------------------------------------------------------------------------------------------------------------------------------------------------------|----------------------------------------------------------------------------------------------------------------------------------------------------------------------------------------------------------------------------------------------------------------------------------------------------------------------------------------------------------------------------------|

1.2.2 General construction

The EH pumps are positive displacement Roots vacuum pumps. The pump mechanism is driven by a three-phase electric motor through a hydrokinetic drive (see [Section 1.2.4](#)).

All of the motors are air cooled.

The pump shafts and rotors are made of cast SG iron. The internal and external shaft seals are made of polytetrafluoroethylene (PTFE) or fluoroelastomer.

The pump bearings, gears and seals are lubricated by oil fed from reservoirs in the hydrokinetic drive/gearbox. A series of seals stops the oil from reaching the vacuum side of the EH pump. The hydrokinetic drive/gearbox is evacuated. Inspect the oil levels through sight glasses that are fitted to the hydrokinetic drive/gearbox. Oil filler, oil drainage and external evacuation connections are provided on the hydrokinetic drive/gearbox.

The timing gears on all of the EH1200, EH2600 and EH4200 model pumps are lubricated by oil inside the gear cover. An oil filler connection is provided. The oil level can be inspected through a sight glass fitted to the gear cover.

1.2.3 Principle of operation

The EH pump is shown in [Figure 1](#) and [2](#). The motor shaft drives one of the rotors through the hydrokinetic drive. The 1:1 gears inside the hydrokinetic drive/gearbox drive the second rotor in the opposite direction inside the stator housing. A small, accurately gauged clearance is maintained between the rotors and between each rotor and the stator wall. This clearance allows the EH pump to operate at high speed without mechanical wear and without the need for lubrication inside the swept volume.

1.2.4 Hydrokinetic drive

The hydrokinetic drive consists of a fluid coupling which connects the electric motor shaft to the rotor. This system is configured so that when the gas load is high, the rotational speed of the rotors is reduced. As the gas load decreases, the rotors accelerate to full speed. This allows continuous operation of the EH pump over the vacuum range without the risk of overloading the motor and removes the need for bypass valves and associated pipelines.

The fluid coupling is viscosity sensitive. The two versions of the EH pump (for hydrocarbon and PFPE oils) have fluid coupling drives which are specifically designed for the type of oil used in the pump.

1.3 Chemical & ATEX pumps

This manual does not cover these applications. They are covered in publication number A301-51-880.

2 Technical Data

2.1 Operating and storage conditions

Table 1 - Operating and storage conditions

Ambient operating temperature range	5 °C to 40 °C
Ambient storage temperature range	-20 °C to 80 °C
Maximum ambient operating humidity	90% RH
Protection degree (as defined by IEC 529)	IP44
Recommended backing pumps	See Note above

2.2 Performance

CAUTION

On each pump the hydrokinetic coupling is configured to account for the oil type (density) and pump rotational speed (50 or 60 Hz). Changes to the oil or rotation speed could result in the pump drawing excess power.

Table 2 - Performance data

Rotational speed: 50 Hz electrical supply 60 Hz electrical supply	0 to 2900 r min ⁻¹ 0 to 3500 r min ⁻¹			
Maximum outlet pressure (see Section 1.2.4)	1000 mbar absolute, 1 x 10 ⁵ Pa			
Pressure differential across EH pump (determined by the hydrokinetic drive):				
Pump	50 Hz electrical supply		60 Hz electrical supply	
EH250/EH250FX	0 to 180 mbar	0 to 1.8 x 10 ⁴ Pa	0 to 150 mbar	0 to 1.5 x 10 ⁴ Pa
EH500/EH500FX	0 to 110 mbar	0 to 1.1 x 10 ⁴ Pa	0 to 90 mbar	0 to 9 x 10 ³ Pa
EH1200/EH1200FX	0 to 90 mbar	0 to 0.9 x 10 ⁴ Pa	0 to 75 mbar	0 to 7.5 x 10 ³ Pa
EH2600FX	0 to 80 mbar	0 to 8 x 10 ³ Pa	0 to 67 mbar	0 to 6.7 x 10 ³ Pa
EH2600	0 to 120 mbar	0 to 1.2 x 10 ⁴ Pa	0 to 67 mbar	0 to 6.7 x 10 ³ Pa
EH4200FX	0 to 60 mbar	0 to 6 x 10 ³ Pa	0 to 50 mbar	0 to 5 x 10 ³ Pa
EH4200	0 to 70 mbar	0 to 7 x 10 ³ Pa	0 to 50 mbar	0 to 5 x 10 ³ Pa

2.3 Recommended primary (backing) pumps

Table 3 - Recommended primary (backing) pumps

Primary Pump	EH250	EH500	EH1200	EH2600	EH4200
212J	✓	✓	✓		
412J		✓	✓	✓	✓
E2M40	✓	✓			
E2M80	✓	✓	✓		
E2M175		✓	✓	✓	
E2M275		✓	✓	✓	✓
ES100	✓	✓			
ES200		✓	✓		
ES300		✓	✓	✓	✓
ES630			✓	✓	✓
IDX1000			✓	✓	✓
IDX1300			✓	✓	✓

2.4 Mechanical data

Table 4 - Mechanical data

Dimensions	See Figure 3 to 7	
Mass	EH250 EH250FX	63 kg 63 kg
	EH500 EH500FX	100 kg 100 kg
	EH1200 EH1200FX	151 kg 151 kg
	EH2600 EH2600FX	405 kg 405 kg
	EH4200 EH4200FX	485 kg 485 kg

2.5 Electrical data

Note: Motor data can be found on the motor rating plate and in the terminal box of the motor.

Table 5 - Electrical data

Electrical supply voltage	380/400 V	230/460 V	200 V	200/380 V
Supply frequency	50 Hz	60 Hz	50 Hz	60 Hz
Pump(s)	Motor rated power			
EH250	2.2 kW		2.2 kW	
EH500	2.2 kW		2.2 kW	
EH1200	3 kW		3 kW	
EH2600	11 kW		11 kW	
EH4200	11 kW		11 kW	

2.6 Lubrication data

Note: Edwards Safety Data Sheets for the oils and grease specified below are available on request.

Table 6 - Lubrication data

Recommended oil type Hydrocarbon pumps PFPE pumps	Ultragrade 20 Fomblin YVAC 16/6		
Recommended grease type *	Fomblin AR555		
Oil capacity:	All EH250	All EH500	All EH1200
Gear cover	-	-	1.25
Hydrokinetic drive/gearbox	1.5	1.5	2.4
Shaft seal reservoir	0.125	0.125	0.125
	All EH2600	All EH4200	
Gear cover	3.5	3.5	
Hydrokinetic drive/gearbox	6.5	6.5	
Shaft seal reservoir	0.45	0.45	

* For use with all EH250FX and EH500FX pumps

2.7 Hydrokinetic drive/gearbox nitrogen supply

Table 7 - Hydrokinetic drive/gearbox purge nitrogen supply data

Regulated pressure*	0.3 to 0.5 bar gauge, 3×10^4 to 5×10^4 Pa
---------------------	-------------------------------------------------------------

* Only applies to the following pumps: EH1200, EH2600 and EH4200.

2.8 Cooling water data

Note: The EH1200 pump can be operated continuously without cooling water if the inlet pressure is kept below 5 mbar (5×10^2 Pa) and the pumpdown time is no longer than 10 minutes.

Table 8 - Cooling water supply data: EH pumps

Recommended cooling water flow (with inlet temperature of 20 °C)	
EH1200	3 l min ⁻¹
EH2600	6 l min ⁻¹
EH4200	6 l min ⁻¹
Recommended cooling water supply pressure	2 to 6 bar gauge, 3 to 7 bar absolute, 3 x 10 ⁵ to 7 x 10 ⁵ Pa
Permissible temperature range	5 to 35 °C

2.9 Noise and vibration data

Table 9 - Noise and vibration data

Vibration level	< 1.8 mm s ⁻¹ r.m.s. in the range 10 to 1000 Hz				
Continuous A-weighted sound pressure level measured at 1 metre from the EH pump*:					
	EH250	EH500	EH1200	EH2600	EH4200
	70 dB(A)	70 dB(A)	70 dB(A)	75 dB(A)	75 dB(A)

* The noise level was measured in accordance with ISO2151 and with the pump running at <0.1 mbar on 50 Hz supply. Running on a 60 Hz supply or at higher inlet pressures will increase the noise level.

2.10 Connections

Table 10 - Connections

Cooling water connections:					
Inlet					
Outlet					
Vacuum connections:					
	EH250	EH500	EH1200	EH2600	EH4200
Inlet	ISO63	ISO100	ISO160	ISO160	ISO250
Outlet	ISO40	ISO63	ISO100	ISO100	ISO100

2.11 Materials of construction of components exposed to pumped gases

Table 11 - Materials of construction

Stator and headplates	Grey cast iron, grade 250 (BS1452)
Rotors	SG iron, grade 420/12 (BS2789)
Hydrokinetic drive/gearbox cover	Aluminium LM25TF (BS1490)
Housing O-rings	Fluoroelastomer
Hydrokinetic drive/gearbox shaft seals	Fluoroelastomer
Internal pump shaft seals	PTFE (polytetrafluoroethylene)
Hydrokinetic drive/gearbox cooling coils	Copper/brass
EH1200, EH2600 and EH4200 after-cooler	Copper/brass
Headplate jointing compound	Loctite 518

2.12 Azide compatibility

The standard pumps are not Azide compatible as they are fitted with copper cooling coils which are exposed to process. For further information, contact Edwards.

2.13 Item Numbers

Table 12 - Item numbers

	380/400 V	230/460 V	200 V	200/380 V
	3 phase		3 phase	
	50 Hz	60 Hz	50 Hz	60 Hz
Hydrocarbon				
EH250	A301-05-945	A301-06-946	A301-05-934	A301-06-934
EH500	A302-05-945	A302-06-946	A302-05-934	A302-06-934
EH1200	A305-05-945	A305-06-946	A305-05-934	A305-06-934
EH2600	A307-05-945	A307-06-946	A307-05-934	A307-06-934
EH4200	A309-05-945	A309-06-946	A309-05-934	A309-06-934
PFPE				
EH250FX	A301-07-945	A301-08-946	A301-07-934	A301-08-934
EH500FX	A302-07-945	A302-08-946	A302-07-934	A302-08-934
EH1200FX	A305-07-945	A305-08-946	A305-07-934	A305-08-934
EH2600FX	A307-07-945	A307-08-946	A307-07-934	A307-08-934
EH4200FX	A309-07-945	A309-08-946	A309-07-934	A309-08-934

Figure 3 - EH250/EH250FX dimensions (mm)

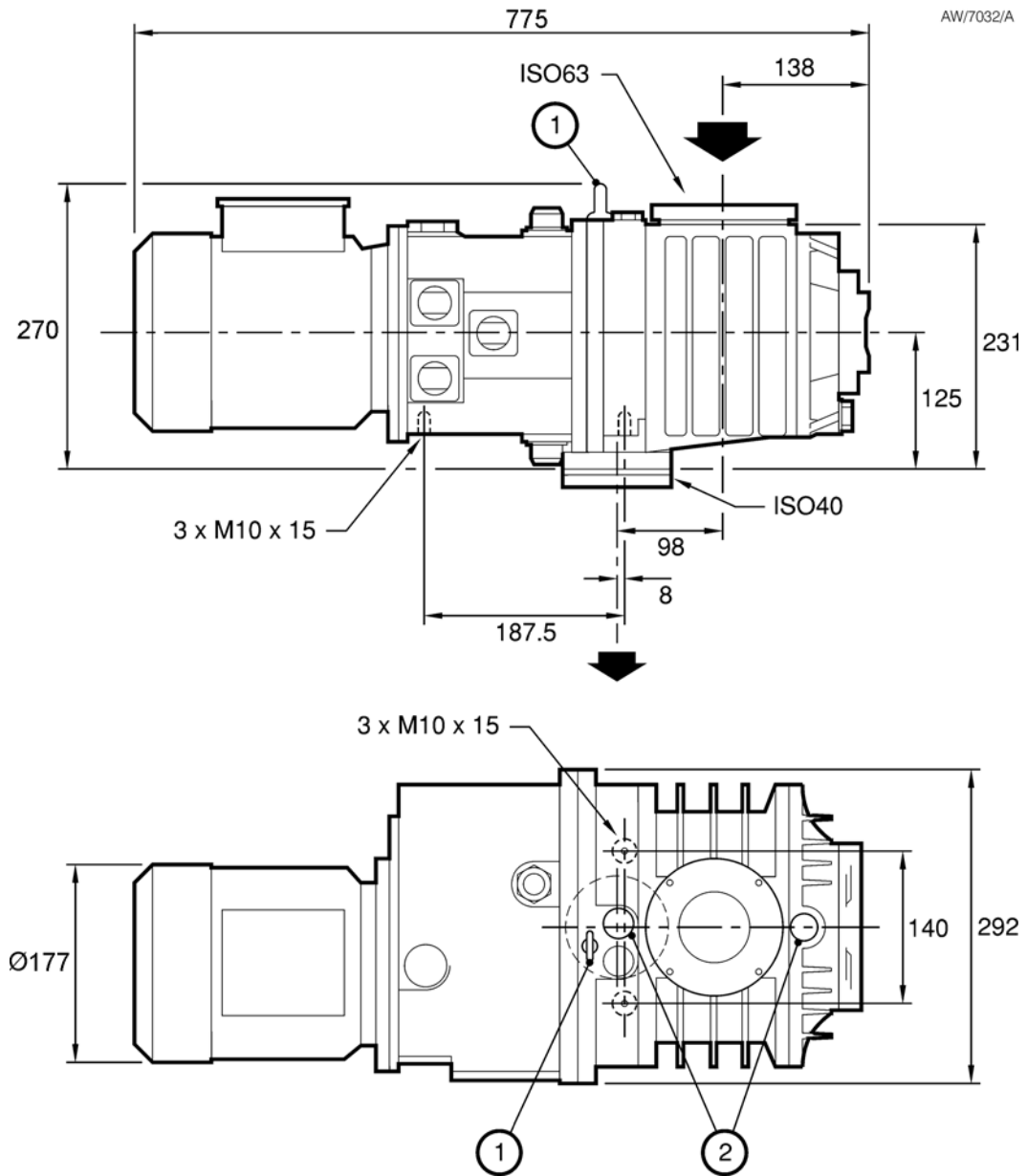

- 1. Lifting bolt
- 2. External evacuation port

Note: Allow 25 mm around the pump exterior for variation in component dimensions and air cooling.

Figure 4 - EH500/EH500FX dimensions (mm)

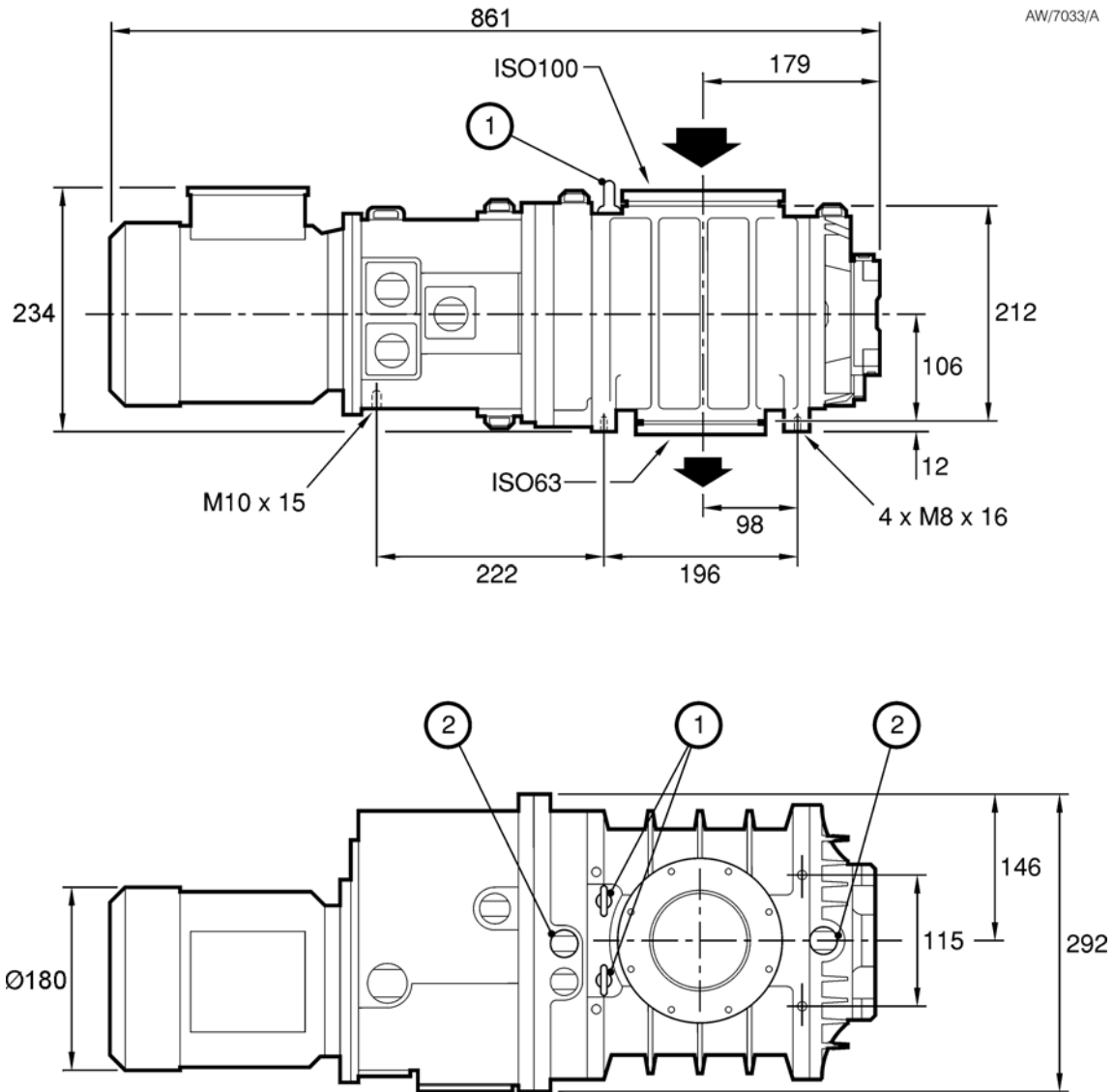

- 1. Lifting bolts
- 2. External evacuation port

Note: Allow 25 mm around the pump exterior for variation in component dimensions and air cooling.

Figure 6 - EH2600/EH2600FX dimensions (mm)

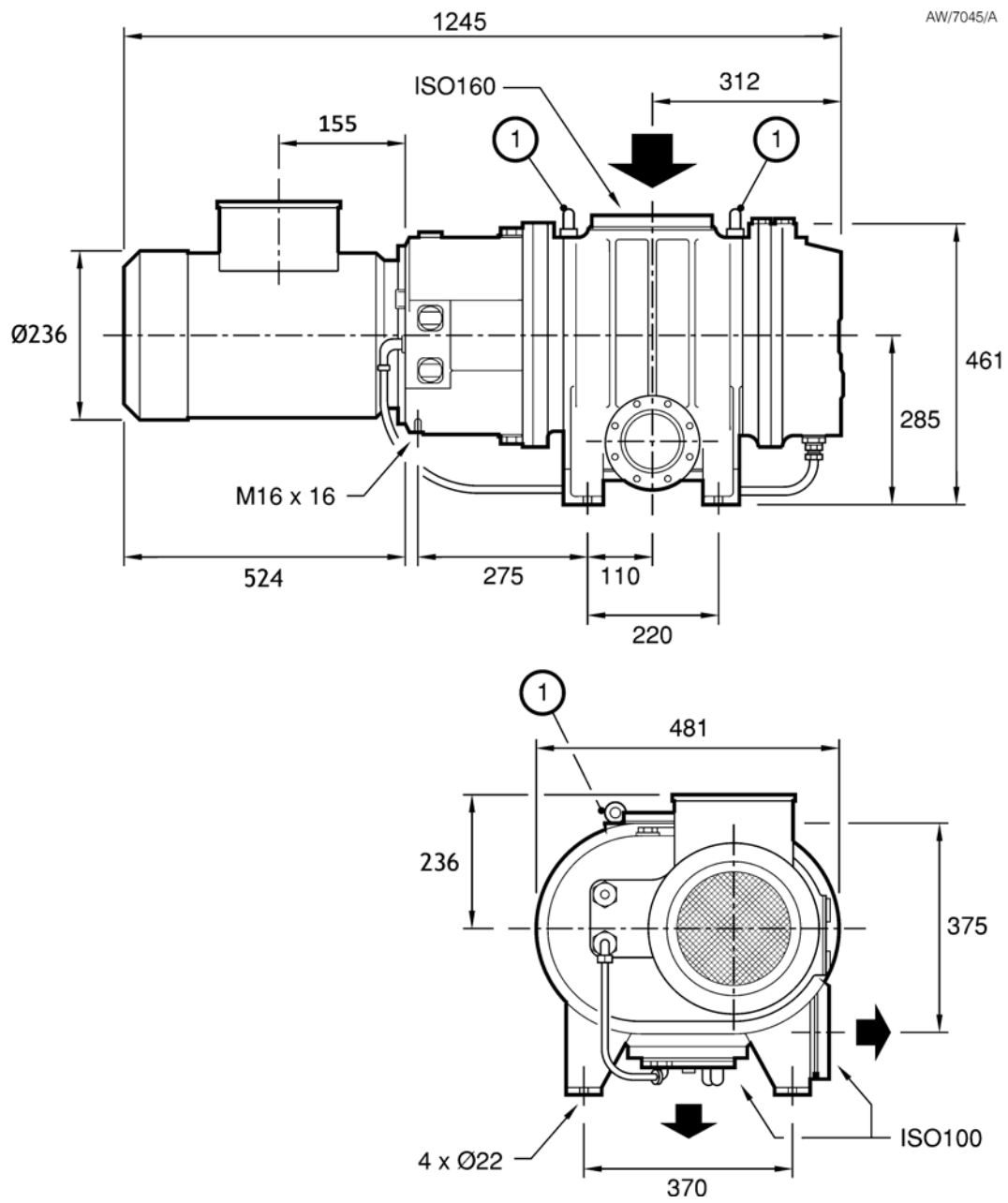

1. Lifting bolts

3 Installation

3.1 Safety



WARNING

Obey the safety instructions in this Section and take note of appropriate precautions. Failure to observe these instructions may result in injury to people and damage to equipment.

- A suitably trained and supervised technician must install the pump.
- Ensure that the installation technician is familiar with the safety procedures which relate to the products pumped.
- Wear the appropriate safety clothing when coming into contact with contaminated components.
- Dismantle and clean contaminated components inside a fume cupboard.
- Vent and purge the vacuum system before starting installation work.
- Check all required components are available and are of the correct type before starting work.
- Ensure that debris does not enter the EH pump during installation. The use of inlet mesh is recommended.
- Disconnect other components in the pumping system from the electrical supply so that they cannot be operated accidentally.
- Do not reuse O-rings and seals.
- Ensure that the cooling air flow through the pump motor cooling fan cannot be obstructed.
- Ensure that all electrical cables, nitrogen pipelines and cooling water pipelines are safely positioned, secured and routed, so that they do not present a trip hazard.
- Provide adequate access to all pump servicing points and oil level sight glasses.
- Leak test the system after installation work is complete and seal any leaks found to prevent leakage of hazardous substances out of the system and leakage of air into the system.

3.2 System requirements

Consider the following points when designing the pumping system:

- Use a suitable backing pump: refer to [Section 2.1](#) and [2.2](#).
- The EH pump must be mounted on a firm, level surface.
- Vacuum pipelines must be adequately supported to stop the transmission of stress to pipeline joints.
- If necessary, incorporate flexible pipelines in the system pipelines to reduce the transmission of vibration and to prevent loading of the coupling joints. When using flexible pipelines, ensure that the flexible pipelines have a maximum pressure rating that is greater than the highest pressure that can be generated in the system. Ensure that vacuum loads are supported.
- Ensure that the design incorporates all appropriate safety precautions if toxic or particulates will be pumped.
- Purge with an inert gas when shutting down the pumping system to dilute dangerous gases to safe concentrations. Consult Edwards or the supplier for advice.

If the EH pump will be fitted in a new system, ensure that all preliminary pipelines have been installed and that a suitable base for the EH pump has been prepared before starting installation.

Check that the following services and facilities are available for connection to the EH pump:

- Cooling water supply and return.
- Electrical supply.
- Exhaust extraction system.
- Inlet mesh (if required, to prevent the ingress of debris during commissioning).

3.3 Unpack and inspect



WARNING

Use suitable lifting equipment to move the pump. Failure to do so can cause injury to people and damage to the equipment. Refer to [Section 2.4](#) for the mass of the pump.

Use the following procedure to unpack and inspect the EH pump:

1. Place the pallet in a convenient position with a fork lift truck or a pallet truck.
2. Remove all packing materials.
3. Use suitable lifting gear to remove the EH pump from its pallet:
 - On all pumps, attach the lifting gear to the centre pair of lifting bolts ([Figure 1 to 3](#), item 1) on the EH pump.
 - All EH2600 pumps have centres of mass that are offset towards the motor. On these pumps, fit an additional support strap to the motor (behind the lifting bolt) to support the pump and prevent it from tilting when lifted.
4. Remove all protective covers and inspect the EH pump.
5. If the pump is damaged, notify the supplier and the carrier in writing within three days; state the Item Number of the pump together with the order number and the supplier's invoice number. Retain all packing materials for inspection. Do not use the pump if it is damaged.
6. If the EH pump will not be used immediately, refit the protective covers. Store the EH pump in suitable conditions as described in [Section 6.1](#).

3.4 Fill the pump with oil

WARNING



Changing the oil in an EH pump from hydrocarbon to PFPE could potentially cause a safety hazard. PFPE EH pumps are generally used in hazardous applications which may involve the pumping of gases with high concentrations of oxygen. If hydrocarbon oil comes into contact with gases with an oxygen concentration greater than 25%, an explosion can occur.

Converting an EH pump that has been used on Hydrocarbon oil for use on PFPE oil requires the pump internals to be cleaned. This usually requires the pump to be serviced.



WARNING

Ensure that the correct grade of oil is used and that the oil levels in the EH pump are correct. If an incorrect oil is used or if an oil level is incorrect, EH pump performance may be affected and the EH pump may be damaged, which will compromise its constructional safety.

3.4.1 Hydrokinetic drive/gearbox

We recommend that the hydrokinetic drive/gearbox oil level is maintained at the recommended oil level shown in [Figure 8](#), item 5; if the oil level is above or below the recommended oil level, the performance of the EH pump may be affected.

Do not allow the oil level to fall below the bottom of the reflector plate ([Figure 8](#), item 4) or the EH pump may be damaged.

1. Remove the hydrokinetic drive/gearbox oil filler plug ([Figure 1](#), item 3).
2. Refer to [Figure 8](#). Fill the hydrokinetic drive/gearbox with the recommended type of oil until the oil level reaches the recommended oil level (5) at the top of the reflector plate (4) in the oil level sight glass (3).
3. Refit the hydrokinetic drive/gearbox oil filler plug.

3.4.2 Shaft seal reservoir



WARNING

Ensure that the correct vented filler plug is fitted in the shaft seal reservoir. If using a non-vented plug, the reservoir will be pressurised and the oil sight glass may fracture.

Edwards recommend filling the shaft seal reservoir so that the oil level is at the recommended oil level as shown in [Figure 8](#), item 2.

The EH pump can be operated as long as the oil level is above the bottom of the reflector plate. Do not allow the shaft seal oil level to fall below the bottom of the reflector plate or the EH pump may be damaged. Use the same oil that was used to fill the hydrokinetic drive/gearbox.

1. Remove the shaft seal reservoir vented oil filler plug ([Figure 1 and 2](#), item 2).
2. Refer to [Figure 8](#). Fill the shaft seal reservoir with oil until the oil level is at the recommended oil level (2) at the top of the reflector plate (6).
3. Refit the vented oil filler plug.

Figure 8 - Sight glasses

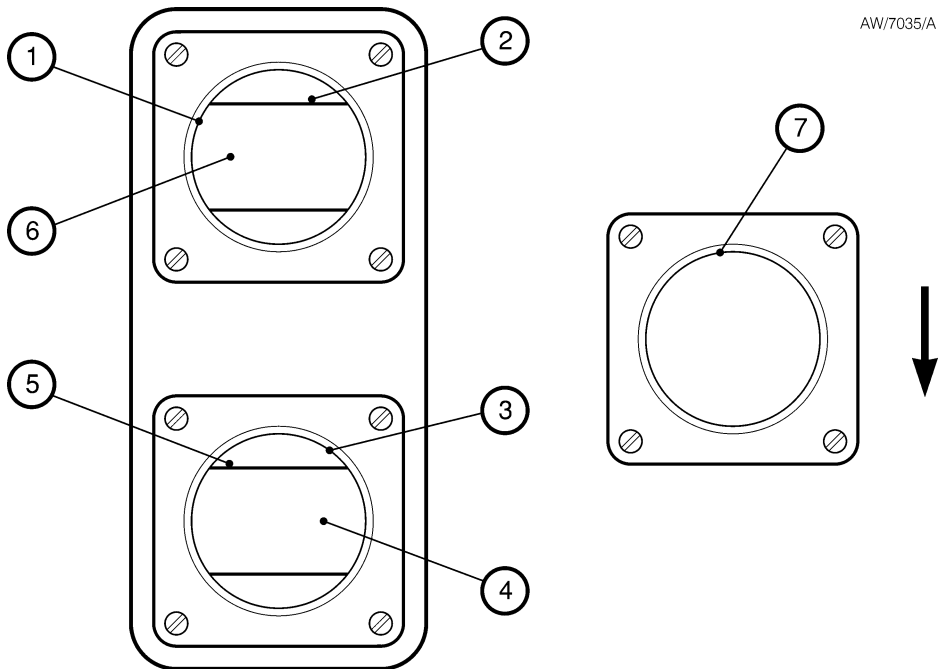

1. Shaft seal reservoir sight glass
2. Shaft seal reservoir recommended oil level
3. Hydrokinetic drive/gearbox sight glass
4. Hydrokinetic drive/gearbox reflector plate
5. Hydrokinetic drive/gearbox recommended oil level
6. Shaft seal reflector plate
7. Direction of rotation sight glass* (the arrow shows the correct direction)

* Not fitted to EH2600 and EH4200

3.4.3 Gear cover (all EH1200, EH2600 and EH4200 model pumps only)

Use the following procedure to fill the gear cover on all EH1200, EH2600 and EH4200 pumps. Use the same oil that was used to fill the hydrokinetic drive/gearbox and shaft seal reservoir.

1. Remove the oil filler plug on the top of the gear cover (Figure 2, item 7).
2. Fill the gear cover with oil until the oil level is at the middle of the reflector plate in the gear cover oil level sight glass (Figure 2, item 9).
3. Refit the oil filler plug.

3.5 Cooling water connections (all EH1200, EH2600 and EH4200 pumps only)

Note: Refer to Section 2.8 for the cooling water requirements.

Connect the cooling water supply and return lines. One connector is on the rear of the hydrokinetic drive/gearbox, the other connector is on the underside of the gear cover. The supply and return lines can be connected to either of the connectors; the direction of cooling water flow is not important.

Refer to Section 2.8 for the minimum cooling water flow rate required. If the danger of the condensation of gases in the booster is not process critical, always connect the supply line to the gearbox cover first.

3.6 Electrical connections



WARNING

Ensure the electrical installation of the EH pump conforms with local and national safety requirements. It must be connected to a suitably fused and protected electrical supply with a suitable earth (ground) point.

3.6.1 Electrical supply configuration

Refer to the wiring instructions provided with the pump motor. Configure electrical connections according to the manufacturer's instructions.

3.6.2 Motor connections



WARNING

Provide suitable strain relief on the electrical supply cable. If not, the cable (or wires in the cable) may become disconnected from the pump and there may be a risk of injury or death by electric shock.



WARNING

Connect the electrical supply to the motor through a contactor which has a manual reset control.



WARNING

Connect the electrical supply to the motor so that it is automatically switched off if the backing pump stops. If not, the EH pump may overheat if it continues to operate when the backing pump is stopped.



WARNING

Ensure that the EH pump can be isolated and locked out from the electrical supply.

CAUTION

The motor must be correctly configured and the electrical connections must be correct for the electrical supply. If not, the motor can be damaged.

Connect the supply through a contactor which has overload protection or use a controller which incorporates a contactor.

Use a contactor that has a manual reset control. If not, the EH pump could automatically restart after an electrical overload or an electrical supply failure.

Use a suitable multi-wire cable and a suitable cable gland (see [Step 4](#) below) to connect the electrical supply to the pump motor.

Connect the motor to the electrical supply as described in the following procedure.

1. Remove the motor terminal box cover ([Figure 1](#) and [2](#), item 1).
2. Check the electrical supply voltage and frequency. If necessary, configure the motor (that is, the terminal wires and any links) to operate with the supply voltage. Refer to the wiring instructions supplied with the pump motor.
3. Remove the plug from the cable entry hole that will be used for the electrical supply cable. Choose the most suitable hole for the application.
4. Fit a suitable cable gland to the cable entry hole. The cable gland (and adaptor, if fitted) must provide a protective seal to IP44 (or higher). Refer to [Table 13](#) for the cable gland hole sizes.
5. Pass the electrical supply cable through the cable gland.
6. Connect the wires of the cable to the appropriate terminals, as shown in the wiring instructions supplied with the pump motor.
7. Tighten the cable gland.

Table 13 - Motor cable gland hole sizes

Pump type	Motor frame size *	Electrical supply cable gland hole size (ISO)
EH pumps	90, 100	20
	132	25
	160	32

* As shown on the motor label.

3.7 Check the direction of pump rotation



WARNING

Blank the inlet or connect the EH pump to the vacuum system before checking the direction of pump rotation. If not, there is a danger of objects being trapped in the rotating rotors.

It is possible for the three-phase electrical supply to the motor to be phased incorrectly. If the supply is phased incorrectly, the rotors will rotate in the reverse direction or remain stationary. Check the direction of rotation as described below.

1. Check that the EH pump is connected to the vacuum system or that the inlet is blanked off.
2. Connect the backing pump and switch the backing pump on.
3. On all EH2600 and EH4200 model pumps, the correct direction of rotation is indicated by an arrow on the motor fan cover ([Figure 2](#), item 17). To determine the direction of rotation: watch the motor fan inside the fan cover, switch on the EH pump for two or three seconds, then switch the EH pump off.

Use the method above to determine the direction of rotation on all EH250, EH500 and EH1200 pumps. Alternatively, the direction of rotation is also indicated by an arrow next to the direction of rotation sight glass ([Figure 1](#), item 10 and [Figure 2](#), item 14): watch the motor coupling in the sight glass ([Figure 8](#), item 7), switch on the EH pump for two or three seconds, then switch the EH pump off.

4. Check that the direction of rotation of the coupling noted in [Step 3](#) was the same as that indicated by the rotation arrow on the motor or on the direction of rotation sight glass. If the direction of rotation was correct, continue at [Section 3.8](#).
5. If the direction of rotation of the coupling was incorrect:
 - Switch off the backing pump and vent the system; isolate the EH pump from the electrical supply; reverse any two of the phase wires in the motor terminal box.
 - Repeat the check from [Step 2](#) to ensure that the direction of rotation is now correct.

3.8 Connect the pump inlet and outlet



WARNING

Do not exceed the load limits on the pump inlet and outlet flanges as specified in [Figure 9](#). If load limits are exceeded, there will be a risk of leakage of process gases from the EH pump, or of damage to the EH pump.



WARNING

The EH4200 must have an inlet screen fitted at all times. Ingress of large particles can cause the pump casing to fracture. A suitable inlet screen is shown in [Table 18](#). If particles, debris or loose components could enter the EH pump during commissioning or running, fit a suitable inlet filter that can be removed before operating the EH pump on process duties.

Connect the inlet of the EH pump to the vacuum system and connect the outlet of the EH pump to the backing pump and exhaust extraction/abatement systems, as required.

Pump inlet and outlet connections are made with standard ISO flanges, Edwards trapped O-rings and (on the EH250FX pumps only) an Edwards co-seal.

All EH2600 and EH4200 model pumps have two alternative outlet positions: on the underside of the EH pump, and at the side of the EH pump.

As supplied, EH pumps are configured to use the outlet at the side of the EH pump; the flange on the underside of the EH pump is blanked off. When using the outlet on the underside of the pump, remove the blanking plate and O-ring from the outlet on the underside and refit the blanking plate, with a new O-ring, over the side outlet flange.

Take note of the following when connecting the EH pump to the vacuum system.

- Move the EH pump to the required location and ensure that it is level and secure.
- For optimum pumping speeds, ensure that the pipeline connected to the pump inlet is as short as possible and has a bore size not less than the inlet port diameter.
- Use a flexible connection in the pipeline from the vacuum system to the EH pump to reduce vibration and stress in the system pipelines (see [Section 3.2](#)).
- On very dusty applications, use a low impedance inlet filter and pump inlet mesh to minimise abrasion in the EH pump.

Figure 9 - Flange loading limits

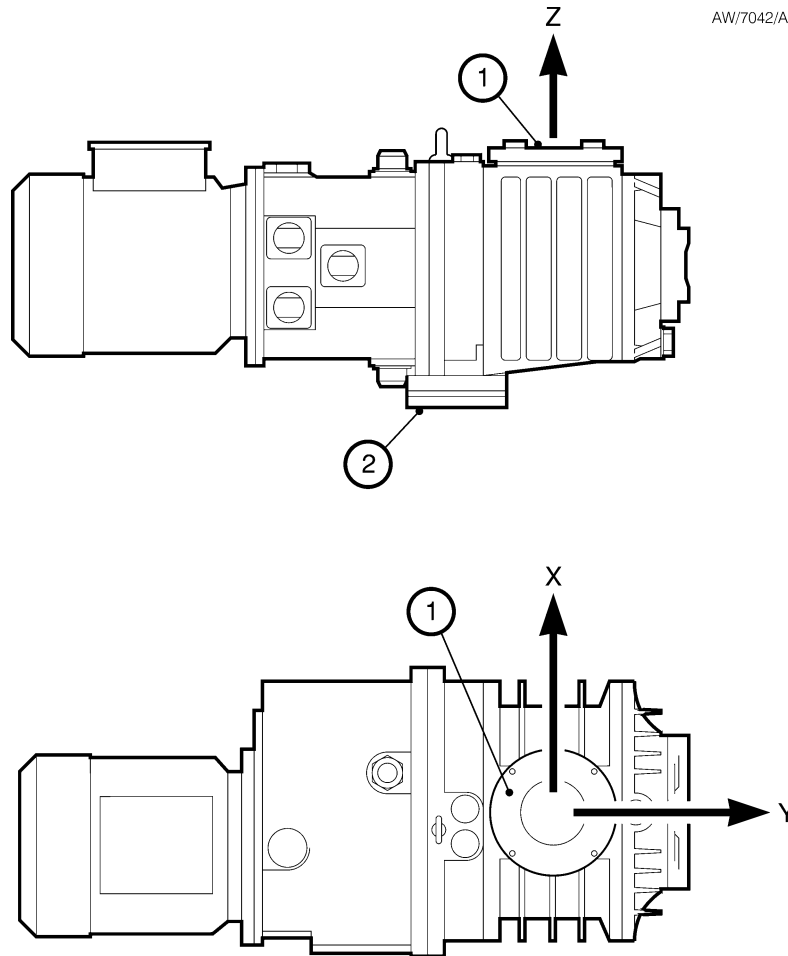

Note: EH250FX pump shown. The flange loading limits apply to all EH pumps.

- 1. Pump inlet
- 2. Pump outlet

- F Force
- M Moment
- R Resultant
- X Load orientation
- Y Load orientation
- Z Load orientation

Maximum force	Pump inlet		Pump outlet	
FX	±1000 N	±224 lbf	±750 N	±168 lbf
FY	±1000 N	±224 lbf	±750 N	±168 lbf
FZ	±2000 N	±449 lbf	±1500 N	±337 lbf
FR	±2400 N	±539 lbf	±1800 N	±404 lbf
Maximum moment	Pump inlet		Pump outlet	
MX	±500 N m	±112 lbf ft	300 N m	± 67 lbf ft
MY	±500 N m	±112 lbf ft	300 N m	± 67 lbf ft
MZ	±500 N m	±112 lbf ft	300 N m	± 67 lbf ft
MR	±870 N m	±195 lbf ft	520 N m	±116 lbf ft

3.9 External evacuation of hydrokinetic drive/gearbox (optional)

The hydrokinetic drive/gearbox may be evacuated using an external pump. A description of the connections required is beyond the scope of this manual.

Contact the supplier or the nearest Edwards company for advice on the use of this facility.

4 Operation

4.1 Operational safety



WARNING

Ensure that the cooling air flow around the EH pump and pump motor is not restricted. If the air flow is restricted, the pump and/or motor will get hotter than normal during pump operation:

- This may result in reduced reliability or the risk of an explosion.
- Care should be taken not to expose parts of the body to vacuum.



WARNING

During operation, parts of the EH pump can become very hot. Do not touch the EH pump.



WARNING

Do not operate the EH pump with the inlet or outlet open to atmosphere. Fingers or other parts of the body may get trapped and may be injured by the rotating pump mechanism.

4.2 Start-up procedure

4.2.1 Pre-start checks

1. Check that the EH pump oil levels are correct (see [Section 3.4](#)).
2. Check that the EH pump is correctly installed, especially after initial installation and maintenance.

4.2.2 Start-up

Start up the EH pump as described in the procedure below. This procedure assumes that the EH pump and the vacuum system are at atmospheric pressure.

1. On all of the EH1200, EH2600 and EH4200 model pumps only:
 - Switch on the cooling water supply and check that there is an adequate flow of cooling water at the correct pressure (see [Section 2.8](#)).
 - Check the water connections for leaks.

Refer to [Section 2.8](#) for the cooling water requirements.

2. Close all valves to atmospheric pressure and ensure that all other openings are sealed.
3. Switch on the backing pump and open the backing valve (if fitted).
4. Switch on the EH pump.
5. Allow the EH pump to run for approximately fifteen minutes to achieve normal operating temperature.
6. Slowly open the pump inlet isolation valve (if fitted).

4.3 Shutdown

CAUTION

If the pump is to be shut down for a long period or is due to be shipped on, refer to [Section 6.1](#) for the storage instructions.

1. Close the pump inlet isolation valve (if fitted).
2. Leave the pump operating for sufficient time such that the pump is thoroughly purged of any hazardous substances.
3. Switch off the EH pump.
4. Open the backing pump air admittance valve (if fitted) and switch off the backing pump.
5. On all of the EH1200, EH2600 and EH4200 model pumps only: turn off the cooling water supply.

5 Maintenance

5.1 Safety information



WARNING

Obey the safety instructions in this Section and take note of appropriate precautions. Failure to observe these instructions may result in injury to people and damage to equipment.

- A suitably trained and supervised technician must maintain the pump.
- Dismantle the pump in a clean workshop environment, with the correct tools and safety facilities available.
- Ensure that the maintenance technician is familiar with the safety procedures that relate to the products processed by the pumping system.
- Wear the appropriate safety clothing when coming into contact with contaminated components.
- Dismantle and clean contaminated components inside a fume cupboard.
- Allow the pump to cool for at least three hours before starting maintenance work.
- Vent and purge the pumping system with nitrogen before starting maintenance work.
- Check that all the required parts are available and of the correct type before starting work.
- Isolate the pump and other components from the electrical supply so that they cannot be operated accidentally.
- Re-check the pump rotation direction if the electrical supply has been disconnected.
- Do not reuse O-rings or seals.
- Dispose of components and waste oil safely (see [Section 6.2](#)).
- Take care to protect sealing faces from damage.
- Do not touch or inhale the thermal breakdown products of fluorinated materials which may be present if the pump has been overheated to 260 °C and above. These breakdown products are very dangerous. Fluorinated materials in the EH pump may include oils, greases and seals. The pump may have overheated if it was misused, if it malfunctioned or if it was in a fire. Edwards Safety Data Sheets for fluorinated materials used in the pump are available on request: contact the supplier or Edwards.
- Leak test the system after installation and maintenance to prevent leakage of dangerous substances out of the system and leakage of air into the system.

The EH pump will be contaminated with the process chemicals that have been pumped. Ensure that adequate precautions are taken to protect people from the effects of dangerous substances if contamination has occurred.

Table 14 - Maintenance plan

Operation	Frequency	Refer to Section
Check the oil levels	Weekly	5.3
Inspect the pump connections	Monthly	5.4
Change the pump oil	12 monthly	5.5
Lubricate the rear bearing	12 monthly	5.6
Overhaul the pump	6 yearly	5.7

5.2 Maintenance plan

Table 14 details the maintenance operations necessary to maintain EH pumps in normal use. Instructions for each operation are given in the section shown.

More frequent maintenance may be required if the EH pump is used to pump corrosive or abrasive gases and vapours. If necessary, adjust the maintenance plan according to system requirements.

5.3 Check the oil levels



WARNING

Ensure that the correct grade of oil is used and that the oil levels in the pump are correct. If an incorrect oil is used or if an oil level is incorrect, EH pump performance may be affected and the EH pump may be damaged, which will compromise its constructional safety.

Note: *If there is a loss of oil from the shaft seal reservoir, the shaft seal may have failed. Contact the supplier or an Edwards Service Centre for advice.*

Use the following procedure to check the oil levels in the sight glasses. Refer to [Figure 1](#) and [2](#) for the location of the filler plugs and sight glasses. During normal operation, the hydrokinetic drive/gearbox sight glass ([Figure 8](#), item 3) may appear empty or show a froth because the oil is in circulation around the coupling.

1. Shut down the EH pump, vent it to atmospheric pressure and allow it to cool.
2. Refer to [Figure 8](#). Check the shaft seal oil level. If the oil level is below the bottom of the reflector plate (6), refer to [Section 3.4](#) and refill the shaft seal reservoir.
3. Check the hydrokinetic drive/gearbox oil level. If the oil level is below the top of the reflector plate, refer to [Section 3.4](#) and refill the hydrokinetic drive/gearbox oil reservoir.
4. On all EH1200, EH2600 and EH4200 model pumps only, check the gear cover oil level. If the oil level is below the middle of the reflector plate, refer to [Section 3.4](#) and refill the gear cover.

5.4 Inspect the pump connections

1. Check that the cooling water connections are secure.
2. Inspect the cooling water pipelines and connections for corrosion, leaks and damage.
3. Check that the electrical connections are secure.
4. Check the electrical supply cables for damage.
5. Inspect all the vacuum pipelines for corrosion and damage. Check that all the vacuum connections are secure.

5.5 Change the pump oil

WARNING



Changing the oil in an EH pump from hydrocarbon to PFPE could potentially cause a safety hazard. PFPE EH pumps are generally used in hazardous applications which may involve the pumping of gases with high concentrations of oxygen. If hydrocarbon oil comes into contact with gases with an oxygen concentration greater than 25%, an explosion can occur.

Converting an EH pump that has been used on Hydrocarbon oil for use on PFPE oil requires the pump internals to be cleaned. This usually requires the pump to be serviced.



WARNING

Ensure that the correct grade of oil is used and that the oil levels in the pump are correct. If an incorrect oil is used or if an oil level is incorrect, EH pump performance may be affected and the EH pump may be damaged, which will compromise its constructional safety.

Replace the pump oil as described below. Refer to [Figure 1](#) and [2](#) for the location of the oil filler and drain plugs.

1. Switch off the EH pump, vent it to atmospheric pressure and allow it to cool.
2. Remove the hydrokinetic drive/gearbox oil filler plug.
3. Remove the hydrokinetic drive/gearbox oil drain plug from the underside of the hydrokinetic drive/gearbox and allow the oil to drain into a suitable container.
4. Remove the shaft seal vented oil filler plug. Use a suitable pump to suck the oil out of the shaft seal reservoir.
5. Refit the hydrokinetic drive/gearbox oil drain plug.
6. Refer to [Section 3.4](#) and fill the hydrokinetic drive/gearbox and shaft seal reservoir with oil.
7. Refit the hydrokinetic drive/gearbox oil filler plug and the shaft seal reservoir oil filler plug.
8. On all EH1200, EH2600 and EH4200 model pumps only:
 - Remove the oil filler plug on the gear cover.
 - Remove the oil drain plug from the underside of the gear cover and allow the oil to drain into a suitable container.
 - Refit the oil drain plug and refer to [Section 3.4](#) to refill the gear cover with oil.
 - Refit the oil filler plug.

5.6 Lubricate the rear bearing (All EH250FX and EH500FX model pumps only)



WARNING

When removing the end cover, take note of the exact locations of the spacers and shims (Figure 10, items 3 and 4) inside the end cover. These items must be refitted correctly in order to ensure that the rotor clearance settings remain correct. Altering the rotor clearance settings may compromise the constructional safety of the pump.

Use the following procedure to replace the grease in the rear bearing. Refer to Section 2.6 for the correct type/grade of grease.

1. Switch off the EH pump and isolate it from the electrical supply. Vent the EH pump to atmospheric pressure.
2. Refer to Figure 10. Remove the four plastic cover caps (8) from the bearing end cover (6).
3. Undo and remove the socket-head screws (7) located under the four plastic cover caps.
4. Remove the end cover (6) and O-ring (5). Dispose of the O-ring safely.
5. Note the exact location of the shims (4) and spacers (3) inside the end cover (6). Clean off all visible grease from the end cover taking care not to misplace or damage the shims and spacers.
6. Use a soft, clean, lint free cloth or a plastic or wooden spatula to remove all visible grease from both bearings (2).
7. Fill the visible side of each bearing (2) with clean grease, then lightly force the grease into the bearing.
8. Refill the visible side of each bearing (2) with clean grease.
9. Apply a light wipe of high-vacuum grease to the new O-ring (5) and fit into the groove in the end cover (6).
10. Check that the shims (4) and spacers (3) are correctly located in the end cover (6).
11. Refit the end cover (6) and secure it with the four socket-head screws (7). Tighten the screws evenly and refit the plastic cover caps (8).
12. Leak test the system and seal any leaks found.

5.7 Overhaul the pump

The EH pump can only be overhauled by Edwards service engineers. Contact the supplier or Edwards for advice.

Figure 10 - Lubricate the rear bearing (EH250FX, EH500 and EH500FX pumps only)

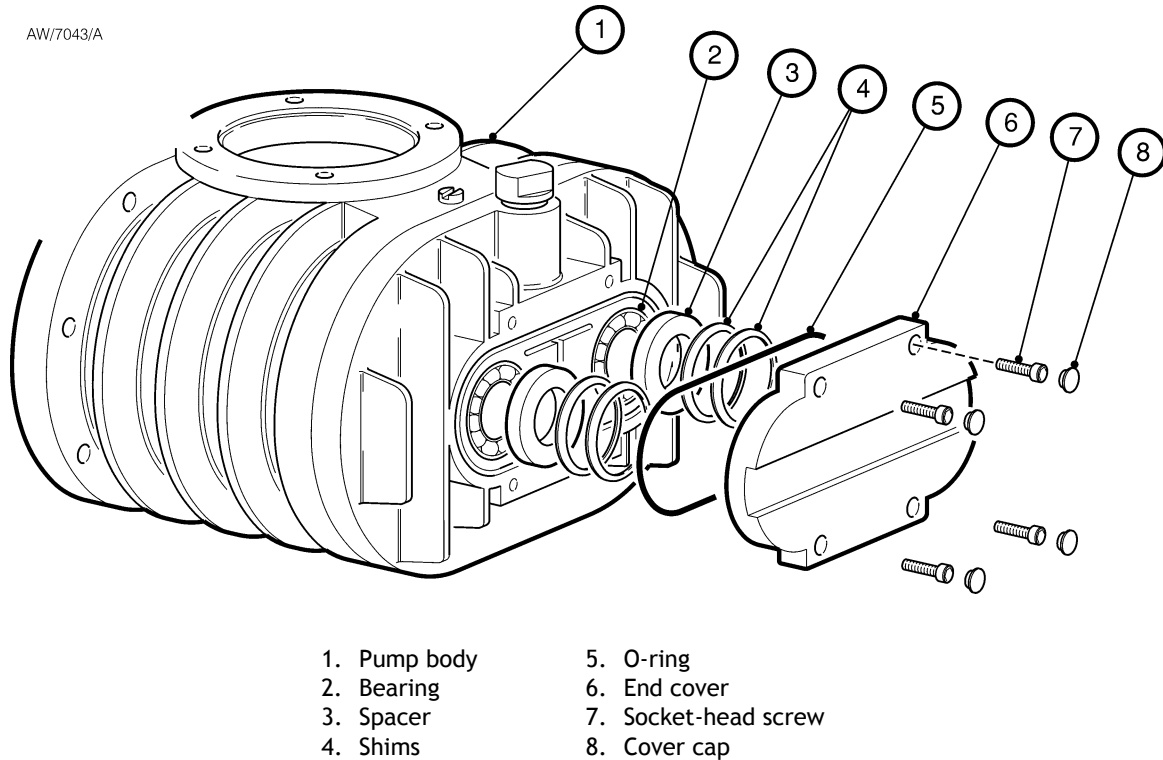

This page has been intentionally left blank.

6 Storage and Disposal

6.1 Storage

CAUTION

Observe the storage temperature limits stated in [Section 2.1](#). Storage below -30 °C will permanently damage the EH pump seals and lubricants.

CAUTION

Ensure that the water lines are emptied if the pump will be stored below 0 °C. If not, the water in the lines will freeze and may cause the pipes to burst. If the pump is to be shipped by air, it is important that the lines are completely emptied of water.

Use the procedure below to store the EH pump.

1. Shut down the EH pump as described in [Section 4.3](#).
2. Isolate the EH pump from the electrical supply and disconnect it from the vacuum system.
3. Clean the EH pump and change the oil as described in [Section 5.5](#).
4. Place protective covers over the inlet and outlet flanges.
5. Store the EH pump in cool, dry conditions until required for use. When required, prepare and install the EH pump as described in [Section 3](#).

6.2 Disposal

Dispose of the pump and any components removed from it safely in accordance with all local and national safety and environmental requirements.

Take particular care with components and waste oil which have been contaminated with dangerous process substances.

The instrument and associated cables are within the scope of the European Directive on Waste Electrical and Electronic Equipment, 2002/96/EC. Edwards offers European customers a recycling service for the instrument/cables at the end of the product's life. Contact Edwards for advice on how to return the instrument/cables for recycling.

This page has been intentionally left blank.

7 Service and Spares

7.1 Introduction

Edwards products, spares and accessories are available from Edwards companies in Belgium, Brazil, China, France, Germany, Israel, Italy, Japan, Korea, Singapore, United Kingdom, U.S.A and a world-wide network of distributors. The majority of these centres employ Service Engineers who have undergone comprehensive Edwards training courses.

Order spare parts from the nearest Edwards company or distributor. When ordering, please state for each part required:

- Model and Item Number of the equipment
- Serial number
- Item Number and description of part.

7.2 Service

Edwards products are supported by a world-wide network of Edwards Service Centres. Each Service Centre offers a wide range of options including: equipment decontamination; service exchange; repair; rebuild and testing to factory specifications. Equipment which has been serviced, repaired or rebuilt is returned with a full warranty.

Local Service Centres can also provide Edwards engineers to support on-site maintenance, service or repair of equipment.

For more information about service options, contact the nearest Service Centre or other Edwards company.

7.3 Spares

The spare parts listed in [Table 15](#) are available for the EH pump.

Table 15 - Spare item numbers

Spare	Item Number
AR555 Fomblin grease (100 g tube)	H113-50-013
End cover O-ring	H021-22-091
Ultragrade 20 oil (1 l)	H110-24-015
Ultragrade 20 oil (4 l)	H110-24-013
Krytox 1514 fluid (1 kg)	H113-08-018
Krytox 1514 fluid (5 kg)	H113-08-020
EH Fomblin (1 kg)	H113-06-019
EH Fomblin (5 kg)	H113-06-020

The spare parts listed in [Table 16](#) are available for the EH250FX and EH500FX pumps.

Table 16 - EH250FX and EH500FX spare parts

Spare	Item Number
Clean and overhaul kit	A301-51-815
Module kit	A301-51-820
Shim kit	A301-51-825
EH250FX inlet mesh assembly 3.3 mm ISO63	C105-21-085
EH250FX inlet mesh assembly 3.5 mm ISO63 stainless steel	A600-41-029
EH500FX inlet mesh assembly 3.3 mm ISO100	C105-23-085
EH500FX inlet mesh assembly 3.5 mm ISO100 stainless steel	A600-41-569

The spare parts listed in Table 17 are available for the EH1200 pumps.

Table 17 - EH1200 spare parts

Spare	Item Number
Clean and overhaul kit	A305-51-815
Module kit	A305-51-820
Shim kit	A307-51-825
EH1200 inlet mesh assembly 3.3 mm ISO160	C105-24-085
EH1200 inelt mesh assembly 3.5 mm ISO160 stainless steel	A600-41-570

The spare parts listed in Table 18 are available for the EH1200 pumps.

Table 18 - EH2600 and EH4200 spare parts

Spare	Item Number
Clean and overhaul kit	A307-51-815
Module kit	A307-51-820
Shim kit	A307-51-825
EH2600 inlet mesh assembly 3.3 mm ISO160	C105-24-085
EH2600 inelt mesh assembly 3.5 mm ISO160 stainless steel	A600-41-570
EH4200 inlet mesh assembly 3.5 mm ISO250 stainless steel	A600-41-571



WARNING

The EH4200 must have an inlet screen fitted at all times. Ingress of large particles can cause the pump casing to fracture.