

Instruction Manual (B)

STP Series Turbomolecular Pumps STP-F2203 Series Pump Specific Information

<i>Model name</i>	<i>Voltage</i>
<i>STP-F2203 series</i>	<i>200 - 240 Va.c.</i>



FOR SALES AND SERVICE PLEASE CALL:

PTB SALES T :: 626.334.0500
service@ptbsales.com
www.ptbsales.com

DATE SERVICED: _____

VIEW OUR INVENTORY

STP pump consists of the three-volumed Instruction Manuals.

Instruction Manual (A):	STP pump generic Instruction Manual Supplied with STP pump
➡ Instruction Manual (B): (This Instruction Manual)	STP pump specific information Supplied with STP pump
Instruction Manual (C):	STP control unit Instruction Manual Supplied with STP control unit



This page intentionally blank

The description of this product consists of the three-volumed Instruction Manuals. Read through each Instruction Manual before operation.

The separate volume contents of each description are as follows:

Instruction Manual (A)

STP pump generic Instruction Manual:

- Introduction
- Installation of the STP pump
- Installation of the STP control unit
- Operation
- Safety functions
- Maintenance and inspection
- Storage and disposal
- Service, Spares and accessories

Instruction Manual (B)

STP Pump specific information:

- Technical data
- How to Secure the STP pump
- Temperature Management System (TMS)

Instruction Manual (C)

STP control unit Instruction Manual:

- Introduction
- Technical data
- Installation
- Operation
- Serial communication protocol
- STP-Link (except for SCU-750)
- Maintenance
- Storage, transportation and disposal
- Service, spares, and accessories

Keep the manuals in an easily accessible location.



EC DECLARATION OF CONFORMITY

Manufacture: Edwards Japan Limited
1078-1, Yoshihashi, Yachiyo-shi, Chiba 276-8523, Japan
EU Representative: Edwards Limited
York Road, Burgess Hill, West Sussex RH15 9TT, UK

declare under our sole responsibility that the product

Product Name: Turbomolecular pump
Model Number: STP-F2203 series
Accessories Covered: TMS Unit, Lon Communication Unit

to which this declaration relates is in conformity with the following standards:

EN 1012-2: 1996

EN 61010-1: 1993 +A2: 1995

EN 61326: 1997/A1: 1998, Class A, EN 61000-6-2: 1999

and with the following provisions of EC directive

Machinery Directive (98/37/EC)

Low Voltage Directive (2006/95/EC)

EMC Directive (2004/108/EC)

Manufacture:

Yachiyo 10th Aug '07
Place and date

Masaharu Miki

Mr. Masaharu Miki
Director, Technology
Edwards Japan Limited

EU representative:

Crawley, 17th August 2007
Place and date

Stephen E. Ormrod

Dr. Stephen E Ormrod
Technical Director
Edwards Limited

VI-DOC-50-005

CONTENTS

Section	Title	Page
1	TECHNICAL DATA	1
1.1	Applicable pump specifications	1
1.1.1	STP pump specifications	2
1.1.2	Condition for the water-cooling unit	3
1.2	External appearance of the STP pump	3
1.3	Label affixing positions	6
1.4	Accessories	7
2	HOW TO SECURE THE STP PUMP	9
2.1	When securing the inlet port with bolts	9
3	TEMPERATURE MANAGEMENT SYSTEM (TMS)	13
3.1	Configuration of the STP pump with the TMS	13
3.2	TMS Connection cable	14
3.3	TMS heater	15
3.4	TMS valve	15
3.5	TMS sensor cable	15
3.6	Installation of the TMS unit	16
3.6.1	Connecting the TMS connection cable to the STP control unit	16
3.6.2	Connecting the pump and cables	16
3.6.3	Connecting TMS connection cable to STP pump	16
3.7	Condition for the TMS unit	17
3.8	Accessories	17

ILLUSTRATIONS

Figure	Title	Page
1	STP-F2203 series: VG250/ISO250F	4
2	STP-F2203 series (with TMS unit): VG250/ISO250F	5
3	Label affixing positions for the STP pump	6
4	Example of securing the STP pump (when securing the inlet port with bolts)	10
5	Shape of reduced diameter shank bolts	11
6	Bolt position for securing the flange (ISO250F)	12
7	Configuration of the STP pump with the TMS	13
8	External view of TMS connection cable	14
9	TMS sensor cable	15

TABLES

Table	Title	Page
1	Tightening torque of bolt	9
2	Maximum torque predicted and recommended securing bolt for inlet port flange	10
3	Shape of reduced diameter shank bolts	11



STP-F2203 Series Turbomolecular Pump

1 TECHNICAL DATA

1.1 Applicable pump specifications

Model Name	Specification	Applicable Control unit ^{*1}
STP-F2203 series	High-flow type	SCU-1500/SCU-1400

^{*1} Applicable control unit: There are different performance specifications between SCU-1500 and SCU-1400. Refer to Section 1.1.1, "STP pump specifications" for the differences.

Naming convention:

- "C" following a pump model name indicates a corrosion resistant^{*2} type (e.g. STP-F2203C).
- "CV" indicates an enhanced corrosion resistant type with TMS^{*3} (e.g. STP-F2203CV).

^{*2} Corrosion resistant: STP pump with anti-corrosive treatment.

^{*3} Temperature Management System: TMS unit (optional accessory) maintains the temperature at the base of the turbomolecular pump by monitoring the temperature with the temperature sensor in the base of the turbomolecular pump, and performing the TMS valve and base heater ON/OFF control.

STP-F2203 Series Turbomolecular Pump

1.1.1 STP pump specifications

The values shown below are typical. They are not guaranteed.

Item		F2203 series
Flange size	Inlet port flange	VG250/ISO250F
	Outlet port flange	KF40
Pumping speed	N ₂ L/s	2200
	H ₂ L/s	1200
Compression ratio	N ₂	>10 ⁸
	H ₂	>10 ³
Ultimate pressure	Pa (Torr)	10 ⁻⁶ (10 ⁻⁸) order [after baking]
Allowable backing pressure ^{*1}	Pa (Torr)	500 (4): Water cooling/TMS unit used
Flow rate of purge gas <N ₂ >	Pa·m ³ /s (SCCM)	3.4×10 ⁻² to 8.4×10 ⁻² (20 to 50)
Rated speed	rpm	27,000
Backup rotational speed ^{*2}	rpm	Approximately 6,000
Starting time ^{*3}	min	7: with SCU-1500 8: with SCU-1400
Stopping time ^{*3}	min	8: with SCU-1500 10: with SCU-1400
Noise	dB	<50 (at 27,000r pm)
Temperature Management System (TMS)		Available
Baking temperature	°C	<120
Lubricating oil		Not necessary
Installation position		Free
Cooling method		Water cooling
Recommended backing-pump	L/min	>1,300
Mass ^{*4}	kg	61
Ambient temperature range	°C	0 to 40
Storage temperature range	°C	-25 to 55
Applicable Control unit		SCU-1500/SCU-1400

^{*1} The pressure is applicable under conditions that N₂ or other similar gas is vacuumed and the backing-pump (pumping speed: 1,300 L/min) is used. When the gas is exhausted intermittently, the gas more than the maximum gas flow-rate can be exhausted. Consult Edwards about conditions.

^{*2} A backup rotational speed is the lowest rotational speed to which the magnetic bearing can be backed up at a power failure.

^{*3} Time varies depending on the control unit used.

STP-F2203 Series Turbomolecular Pump

^{*4} Mass is a value of state that the only standard accessory was installed (except the optional accessory).

Maximum gas flow-rate ^{*5}

Gas	Condition				Maximum gas flow-rate ^{*5}	
	TMS		Cooling water	Purge gas N ₂ gas flow rate	SCU-1500	SCU-1400
	Yes/No	Set point			Pa·m ³ /s (SCCM)	Pa·m ³ /s (SCCM)
N ₂	No	-	Temperature: 5 to 25 °C Flow rate: 2 L/min	3.4×10 ⁻² to 8.4×10 ⁻² (20 to 50)	10 (6000)	8.5 (5000)
	Yes	75°C			4.6 (2700)	4.6 (2700)
Ar	No	-			4.7 (2800)	4.7 (2800)
	Yes	75°C			1.4 (800)	1.4 (800)

^{*5} The maximum gas flow-rate is applicable under conditions that N₂ or Ar gas is vacuumed continuously and the backing backing-pump (pumping speed: 6,500 L/min) is used. It is changed depending on condition. For example, when the gas is exhausted intermittently, the gas more than the maximum gas flow-rate can be exhausted. In this case, contact Edwards.

1.1.2 Condition for the water-cooling unit

Item	Specification
Port type	Rc 1/4 (Female) ^{*1}
Flow rate L/min	2
Water temperature °C	5 to 25
Water pressure MPa (kgf/cm ²)	0.3 (3)

^{*1} Standard type

1.2 External appearance of the STP pump

See the next page.

STP-F2203 Series Turbomolecular Pump

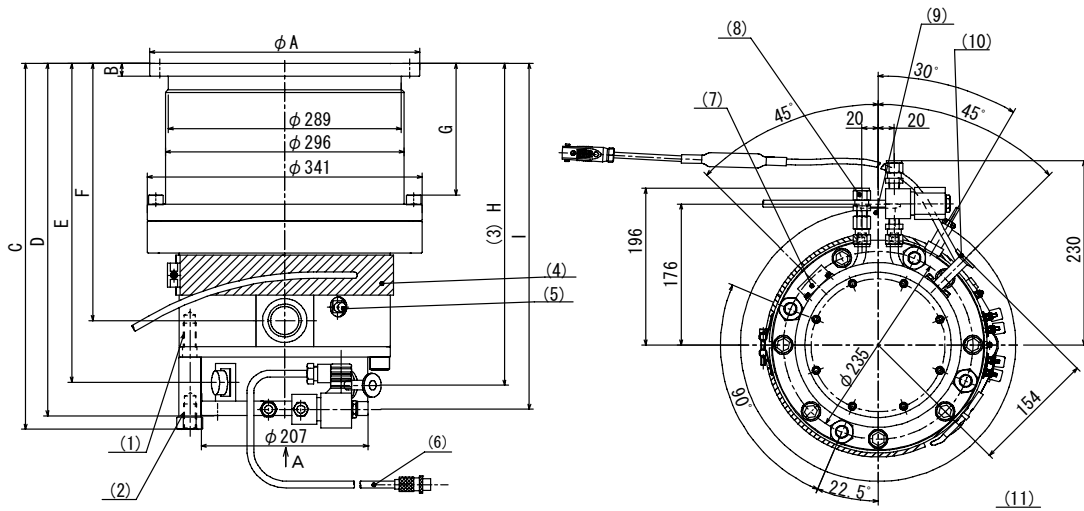

Figure 2 - STP-F2203 series (with TMS unit): VG250/ISO250F

No.	Item	Description
1	Screw hole for legs	4-M16 depth 30
2	Screw hole of legs	4-M16 depth 32
3	Height of the purge port	
4	TMS heater	
5	TMS sensor	
6	TMS valve cable	
7	STP cable connector	
8	Cooling water port	2-Rc ^{*1} 1/4
9	Outlet port flange	KF40
10	Purge port	KF10
11	Viewed from arrow A	

Inlet port flange	VG250	ISO250F
φ A	350	335
B	18	20
C	431	457
D	414	440
E	372	398
F	295	321
G	138	164
H	376	402
I	406	432

*1 ISO

STP-F2203 Series Turbomolecular Pump

1.3 Label affixing positions

Refer to the Instruction Manual (A) for the details of the labels 1 to 7.

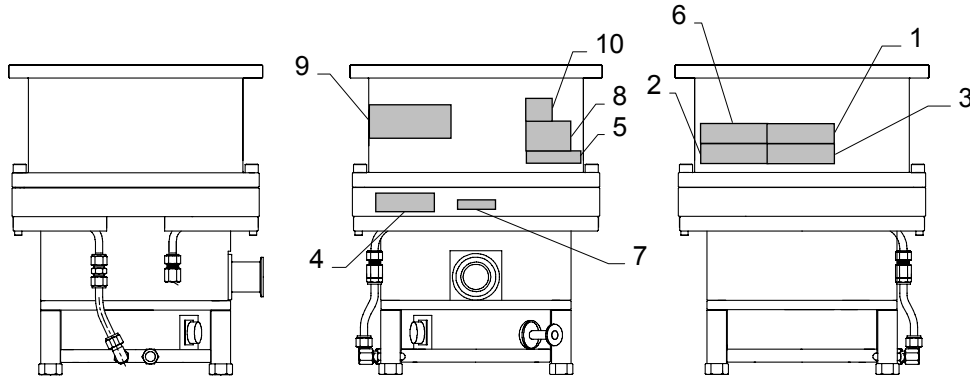

Figure 3 - Label affixing positions for the STP pump

- 1 STP pump installation warning label
- 2 Hot surface warning label
- 3 Heavy product caution label
- 4 Connector caution label
- 5 STP pump/control unit caution label
- 6 TMS heater surface caution label
- 7 Rotational direction instruction label
- 8 Name plate
- 9 Company logo



STP-F2203 Series Turbomolecular Pump

1.4 Accessories

Item	Q'ty	Remarks
Inlet port cover	1	
Outlet port cover	1	
STP connector cover	1	
Blank flange for purge port	1	KF10
Clamping ring for purge port	1	KF10
O-ring washer for purge port	1	KF10
Leg	4	
Instruction Manual (B)	1	This manual





STP-F2203 Series Turbomolecular Pump

1

TECHNICAL DATA

This page intentionally blank.

2 HOW TO SECURE THE STP PUMP



WARNING

The STP pump is provided with a high-speed rotor. Any internal abnormality/error may result in a jump in rotational torque leading to personal injury or peripheral equipment damage.

The STP pump is provided with a high-speed rotor. The worst-case failure may result in a jump in rotational torque leading to personal injury or peripheral equipment damage.

The method of securing the STP pump will depend on the installation requirements. Secure the STP pump to the vacuum equipment as follows:

Design and secure the mounting for the STP pump so that it can withstand the maximum rotational torque. Refer to Table 2 for torque in pump abnormality.

Bolt size	Tightening torque (Nm)
M10	24
M12	42

Table 1 - Tightening torque of bolt

When making the legs to secure the base, make them shorter than the ones attached to the STP pump. Use a material that has a tensile strength of 600N/mm² or more.

When securing the base, use stainless steel securing bolts with a tensile strength class of 70 or more.

Note: When using any securing method other than that specified in this manual, contact Edwards.

2.1 When securing the inlet port with bolts

There are two installation methods of the STP pump as shown in Figure 4. Refer to Table 2 for the recommended each of bolts for each method.

Reduced diameter shank bolt (R.D.S.B.) is a fixed bolt which smoothed the threaded portion against the vacuum equipment, and improved strength more than standard bolts.

Figure 5 illustrates the shape of the R.D.S.B.

A torque reduction mechanism against the occurrence of maximum torque is installed in the fitting bolt holes on the ISO250F inlet port flange as shown in Figure 6. Be sure to secure the inlet port flange to the equipment with the recommended bolts and the supplied special washers described in Table 2. The shape of the special washer is shown Figure 6.

Pump model		STP-F2203 series			
Flange type		VG250		ISO250F ^{*1}	
Torque in pump abnormality [Nm]		7.6×10 ⁴		6.5×10 ⁴	
Base (4 positions) securing		No	Yes	No	Yes
Recommended securing bolt for flange	Shape	R.D.S.B. ^{*3}	Standard	R.D.S.B. ^{*3}	R.D.S.B. ^{*3}
	Material ^{*2}	Carbon steel Alloyed steel	Carbon steel Alloyed steel	Carbon steel Alloyed steel	Carbon steel Alloyed steel
	Strength ^{*2}	12.9 or more	12.9 or more	Equivalent to AMS 6419	Equivalent to AMS 6419
	Special washer	Type	Standard	Standard	Figure 6
	Steel	Stainless steel			

^{*1} Torque reduction mechanism with O-ring groove

^{*2} Refer to ISO898-1 (JISB 1051), ISO3506 (JISB 1054) and AMS6419 (Aerospace Material Specification).

^{*3} Refer to Figure 5 for the Shape of Reduced Diameter Shank Bolts. (R.D.S.B.)

Table 2 - Maximum torque predicted and recommended securing bolt for inlet port flange

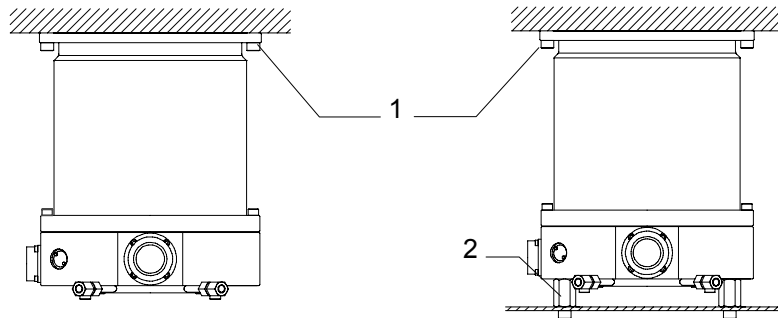

(A) When the base is not secured

(B) When the base is secured

1. Recommended fitting bolt for flange
2. Secure the base

Figure 4 - Example of securing the STP pump (when securing the inlet port with bolts)

STP-F2203 Series Turbomolecular Pump

Refer to Figure 5 for the shape of Reduced Diameter Shank Bolts. (R.D.S.B.)

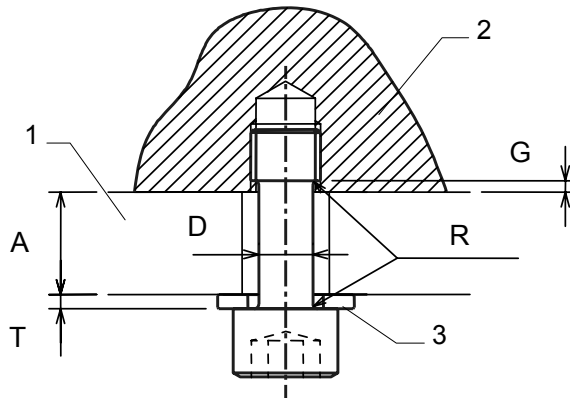

- 1. Inlet port flange
- 2. Vacuum equipment
- 3. Washer

Figure 5 - Shape of reduced diameter shank bolts

Use Table 3 in conjunction with Figure 5. Ensure that the surface of the levelled and smoothed area (expressed by "D" in Figure 5) is free of crack, depression, and other damages.

Flange type	Bolt size	T	A	G	D	R
VG250	M12	2.5 mm	18 mm	3 mm	9.4 mm or more	1 mm or more
ISO250F	M10	2 mm	20 mm		7.9 mm or more	

Table 3 - Shape of reduced diameter shank bolts

CAUTION

Install the flange securing bolts in the proper position with the special square washer shown in Figure 6. Failure to do so may cause abnormal operation of the torque reduction mechanism and damage the pump.

CAUTION

When any internal abnormality/error results in high rotational torque, causing the torque reduction mechanism to operate, the pump may rotate a maximum of 5 degrees around the rotor rotation at axis.

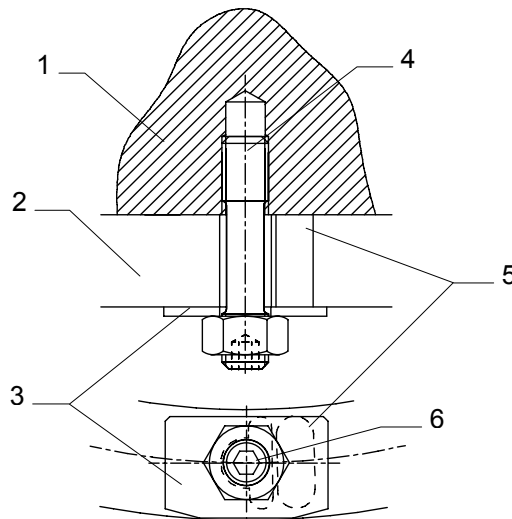

1. Vacuum equipment
2. Inlet port flange
3. Special washer
4. Bolt for securing pump (Stud bolt)
5. Torque reduction mechanism
6. Bolt position

Figure 6 - Bolt position for securing the flange (ISO250F)

3 TEMPERATURE MANAGEMENT SYSTEM (TMS)

WARNING

The STP pump operates at high temperatures while the Temperature Management System (TMS) unit is in operation. NEVER touch the STP pump and its peripheral equipment while TMS unit are in operation. Operators can burn hands.

The Temperature Management System (TMS) maintains the temperature of the turbomolecular pump by monitoring the temperature with temperature sensor in the base of the turbomolecular pump, and performing the TMS valve and TMS heater ON/OFF control.

3.1 Configuration of the STP pump with the TMS

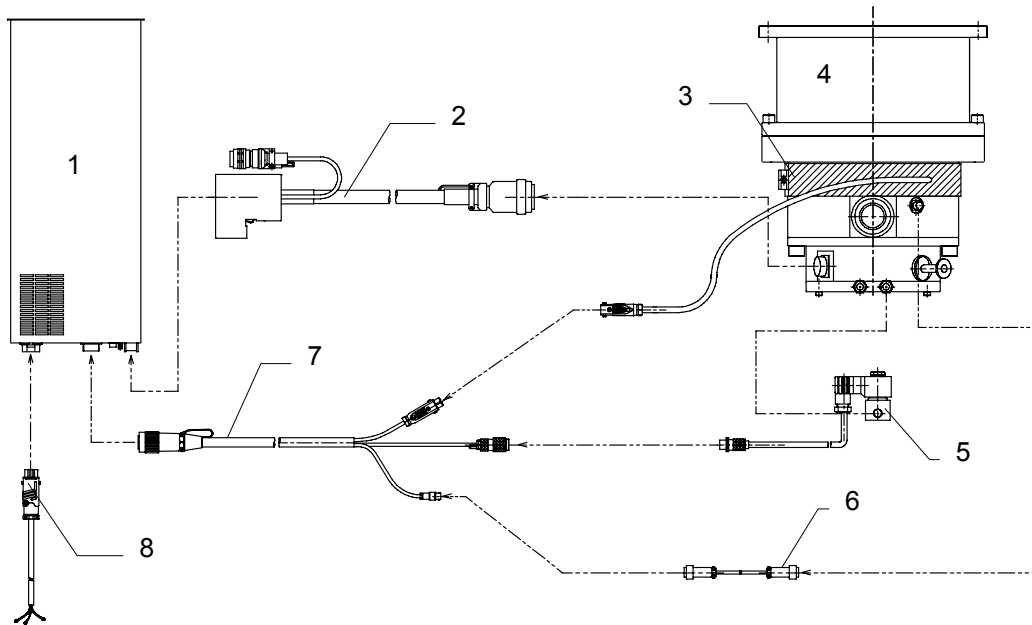

- | | |
|--------------------------|-------------------------|
| 1. STP control unit | 5. TMS valve |
| 2. STP connection cable | 6. TMS sensor cable |
| 3. TMS heater (Built-in) | 7. TMS connection cable |
| 4. STP pump | 8. Power cable |

Figure 7 - Configuration of the STP pump with the TMS

Note: The shape of each part is an example. It varies according to specifications.

3.2 TMS Connection cable

The components of the TMS connection cables are as follows: (see Figure 8)

Item	Description	Function
1	Connector X5A	For the STP control unit
2	CON1 HEATER OUT connector	For the TMS heater
3	CON2 COOLING VALVE OUT connector	For the TMS valve
4	CON3 TC IN connector	For the TMS sensor cable

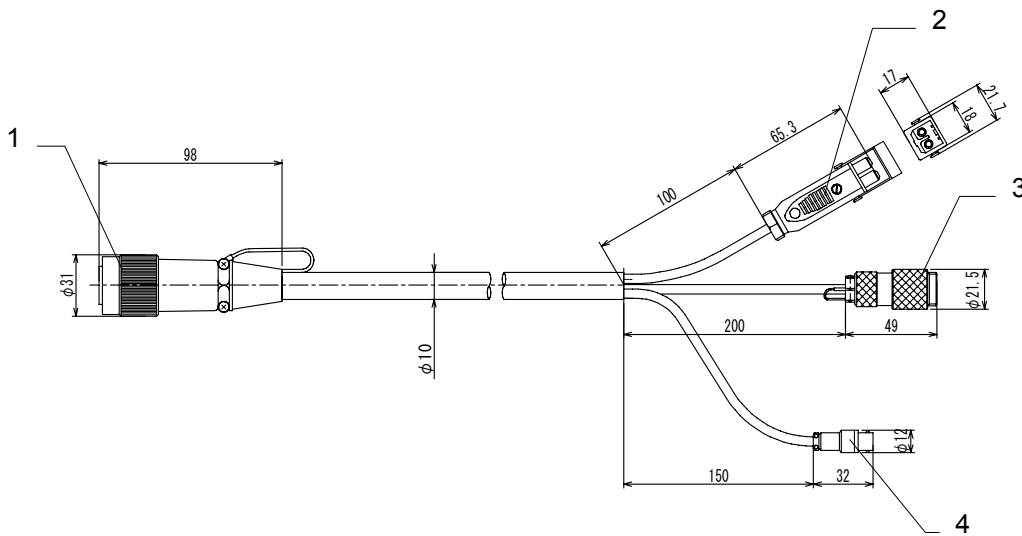

Figure 8 - External view of TMS connection cable

Note: The shape of the TMS connection cable is an example. It varies according to specifications.

3.3 TMS heater

The TMS heater heats the base of the STP pump. It's fitted with the STP-F2203CV series at the factory.

3.4 TMS valve

The TMS valve controls the cooling water in order to maintain a constant temperature inside the STP pump. The shape of the TMS valve varies according to specifications.

3.5 TMS sensor cable

The TMS sensor cable is for reading the TMS sensor signal from the base of the STP pump.

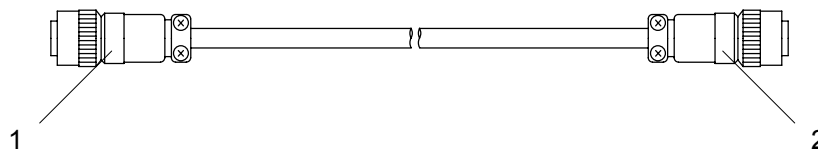

1. TMS connection cable side (5 pin, pin type)
2. STP pump side (5 pin, socket type)

Figure 9 - TMS sensor cable

3.6 Installation of the TMS unit

CAUTION

DO NOT install the TMS unit in places with high temperature, humidity, noise, vibration, or other unstable environment.

CAUTION

DO NOT apply force to the TMS unit and cables during installation and DO NOT bend the cables excessively.

3.6.1 Connecting the TMS connection cable to the STP control unit

Insert the connector X5A of the TMS connection cable into the connector X5 of the STP control unit. (see the "STP Control Unit Instruction Manual (C)" for the position of the connector X5.)

3.6.2 Connecting the pump and cables

Refer to Figure 7, "Configuration of the STP pump with the TMS" to connect the pump and TMS sensor cable, TMS valve proceed as follows:

1. Connect the TMS sensor cable to the connector of the temperature sensor in the base of the pump.
2. Connect the cooling water pipe to the TMS valve. Pay special attention to the port label on the cooling water valve to connect proper port. Connect the NC side (or OUT side) of the TMS valve to the STP pump, and COM side (or IN side) of the TMS valve to the equipment.

Use cooling water under the conditions in Section 3.7, "Condition for the TMS unit".

Note: Procure and connect the cooling water pipe and affix the electromagnetic cooling water valve at your site. The diameter of the valve is Rc1/4 (ISO standard).

3.6.3 Connecting TMS connection cable to STP pump

Refer to Figure 7, "Configuration of the TMS unit".

Connect the TMS connection cable to the STP pump as follows:

1. Connect the cable for the TMS heater to the "CON1 HEATER OUT" connector of the TMS connection cable.
2. Connect the cable for the TMS valve to the "CON2 COOLING VALVE OUT" connector of the TMS connection cable.
3. Connect the TMS sensor cable to the "CON3 TC IN" connector of the TMS connection cable.

STP-F2203 Series Turbomolecular Pump

3.7 Condition for the TMS unit

Item	Condition
Ambient temperature range °C	0 to 40
Storage temperature range °C	-20 to 55
Input voltage	Same voltage as the STP control unit 200 to 240 Vac
Temperature control method	Control ON/OFF of the TMS heater and cooling water
Setting temperature °C	Standard type: 60
Cooling water temperature °C	5 to 25
Quantity of cooling water L/min flow	2
Alarm output	Alarm outputs from the STP control unit

3.8 Accessories

Item	Q'ty	Condition
TMS heater	1	Attached to the STP pump
TMS connection cable	1	With connector at each end
TMS valve	1	Coupling for water cooling port, cable with connector on one side
TMS sensor cable	1	With connector at each end



STP-F2203 Series Turbomolecular Pump

3

TEMPERATURE MANAGEMENT SYSTEM

This page intentionally blank

For more information, contact the nearest Service Office.

Manufacturer:

Edwards Japan Limited

1078-1, Yoshihashi, Yachiyo-shi, Chiba 276-8523 JAPAN

Telephone: Domestic 047-458-8822

International +81-47-458-8822

Facsimile: Domestic 047-458-8833

International +81-47-458-8833