

STP-301/451 Series
Turbomolecular Pump
INSTRUCTION MANUAL
(Third Edition- d)



FOR SALES AND SERVICE PLEASE CALL:

PTB SALES T :: 626.334.0500
service@ptbsales.com
www.ptbsales.com

DATE SERVICED: _____

VIEW OUR INVENTORY

Read through the Safety Precautions and each section of this Manual carefully before using the STP pump.
Keep this Manual in a place where you can quickly access it at any time.

SAFETY PRECAUTIONS

The Safety Precautions in this Manual constitute guidelines to protect operators, the STP pump and its peripheral equipment.

To avoid personal injury and prevent product and/or peripheral equipment damage, observe the Safety Precautions as well as the general safety rules (your country's laws, regulations, safety standards and so on).

If the equipment is used in a manner not specified by BOC Edwards, the protection provided by the equipment may be impaired.

SYMBOLS

The following symbols are used in this manual:



Death or Serious Personal Injury

Failure to follow the guidelines marked with this symbol may result in death or serious personal injury.



Minor Personal Injury, Product and/or Peripheral Equipment Damage

Failure to follow the guidelines marked with this symbol may result in minor personal injury, product and/or peripheral equipment damage.



Items you must follow during operation and maintenance.



ATTENTION : refer to this manual.

BOC Edwards Japan Limited (hereafter called BOC Edwards) cannot perfectly anticipate circumstances of all of hazards or problems. The scope of anticipation is limited to the

precautions included in the



and



specified in this

manual.



The STP pump is provided with a high-speed rotor. Secure the STP pump according to the specified method. Failure to do so may lead to serious personal injury, product and/or peripheral equipment damage if any abnormality/error occurs in the rotor.

The STP pump operates at high temperatures while the baking heater is in operation. NEVER touch the STP pump and its peripheral equipment while the baking heater is in operation.

Operators can burn hands.

Execute the following to prevent an accident caused by the gas.

- Check the properties of the gas to be used, referring to the Material Safety Data Sheet (MSDS) you obtain from the gas supplier. (explosive · combustible · toxic · corrosive, etc) And, keep MSDS and a safety advice of gas supplier.
- Warn of the danger of the gas with the warning label when the use gas is hazardous chemicals materials.
- Always execute gas purge in the pump with the inert gas, and then exhaust residual gases thoroughly from the STP pump when removing the STP pump from the vacuum equipment.
- Secure safety by wearing personal protective equipment when using the gas which might influence damage health. In addition, take appropriate measure for depending upon the properties of the gas to be used.

Exhaust residual gas thoroughly when disposing of the STP pump. If the STP pump is used for any toxic or reactive gas, always clean the STP pump and dispose of it as industrial waste in accordance with guidelines given by the national and/or local government. Residual gas in the STP pump may cause an accident which, for certain gases, may involve serious injury or death.



NEVER use any gas that is not specified as usable in this Manual. The use of such gas may corrode the STP pump and damage it.

A hazardous live voltage may exist at connector/terminal that marked . DO NOT touch the terminal. Doing so may result in electric shock.

When operating connection/disconnection to terminal, always power OFF the STP pump (Switch the breaker "OFF").

Always check the STP pump has stopped, then turn OFF the primary power (switch the breaker "OFF") before proceeding to any of the following operations. Failure to do so may cause the STP pump to rotate accidentally, which may injure operators seriously or result in electric shock. Moreover, do not remove the connector while the pump is rotating. The voltage might be output to connector according to the rotational speed, and it causes the electric shock or the failure.

- Connect or disconnect cables;
- Perform maintenance and inspections such as replacement of fuses as well as inspections of deposit and/or the air cooling fan; or
- Perform investigations into probable causes and action/measures taken in the event of occurrence of a problem.

DO NOT perform the insulation test (insulation resistance test and withstand voltage test) to the STP control unit and STP pump. When performing the insulation test to your equipment, turn "OFF" the STP control unit. The varistor for the power supply line protection is installed to the STP control unit. DO NOT perform the insulation test with the varistor installed. Doing so may result in product damage.

When removing or installing the pump or at maintenance and inspection, follow the precautions below. Failure to do so might hurt your back or cause injuries due to occurrence of an accident such as fall.

- Use a crane or the like when lifting the heavy product of 18kg or more.
- When lifting by hands for unavoidable reason, two or more people must always conduct it.
- When lifting STP control unit with handles, support bottom of STP control unit, do not have only handle.

When "emergency off" (EMO) circuit is installed in the vacuum equipment, consider the following to stop the STP pump safely when the EMO circuit operates.

- When the EMO circuit operates, atmosphere might be introduced in the STP pump depending upon the backing pump. Unite the exhaust gas system to prevent atmosphere from being introduced into the STP pump when the EMO circuit operates. (example: shut the valve) When atmosphere is introduced into the STP pump, the touch down bearing may not operate normally.

Install the STP control unit not only by fitting it with the front panel fitting screws but also by supporting it from the bottom side.

Fitting the STP control unit with the screws only cannot sustain its weight, and therefore resulting in product damage.

Always use the STP pump and STP control unit with same model name, which are specified on their own nameplate. If use the units having different model names, they may not be used. In the latter case, contact service office. If you use the units having the same model name but different serial numbers or change the length of the STP connection cable, the tuning is required. They may not function normally when they are used without

STP-301/451 Series Instruction Manual

tuning. Once tuning is completed, re-tuning is not required unless the configuration (the STP pump serial number, the STP control unit serial number, and the STP connection cable length) is changed.



Use the STP connection cable that has a label affixed

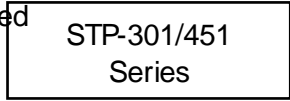

The use of different cables may result in product damage.

Connect the cables securely. NEVER bend nor place heavy objects on the cable.

Doing so may result in electric shock or product damage.

NEVER remove the splinter shield from the STP pump. Doing so may result in product damage.

DO NOT put foreign objects into the STP pump. Doing so may result in product damage.

Always use the power voltage specified on the nameplate for the primary power voltage of the STP control unit. Wire the power cable securely. Incorrect wiring may result in electric shock or product damage.

The wipes used for clean the flange of the pump might become hazardous waste depending upon the solvent (alcohol). Dispose of the contaminated wipes appropriately according to the regulations of each national and/or local government.

NEVER turn OFF the primary power (DO NOT switch the breaker "OFF") while the STP pump is rotating. Doing so may result in product damage.

Perform investigations into probable causes and remove them before restarting the STP pump in the event of the occurrence of a problem. The use of the abnormal STP pump may result in product damage.

DO NOT move the STP pump and the STP control unit while the STP pump is in operation. Doing so may result in product damage.

INTRODUCTION

Thank you very much for purchasing BOC Edwards' turbomolecular pump. The turbomolecular pump is designed to be installed in the vacuum equipment to exhaust gases from it.

This manual covers all items necessary to ensure safe installation, operation and maintenance of the following series of the STP-301/STP-451 turbomolecular pump:

Model Name	Specification
• STP-301	High-vacuum type
• STP-451	High-vacuum type
• STP-301C	High-vacuum type, chemical specific * ¹
• STP-451C	High-vacuum type, chemical specific * ¹

For the specifications of other models, contact BOC Edwards.

In this manual, the above STP pump series is collectively called the "STP pump."

APPLIED STANDARDS

The STP pump conforms to the following directives and standards:

Applied Directives

- EC Machinery Directive
- EC Electromagnetic Compatibility Directive
- EC Low Voltage Directive

Applied Standards

- EN292-1
- EN292-2
- EN60204-1
- EN61326 (class A)
- EN61000-6-2

Applied Standards (Only a some model)^{*2}

- UL3101-1, 1993 (Electrical Equipment for Laboratory Use; Part 1 : General Requirements)

^{*1}: Chemical specific: STP pump with anti-corrosive treatment (responding to chlorine, fluorine or other system gases)

^{*2}: Contact BOC Edwards about recognized model

PRECAUTIONS

- 1) No part of this manual may be reproduced in any form by any means without prior written permission from BOC Edwards.
- 2) BOC Edwards pursues a policy of continuing improvement in design and performance of this product. The right is, therefore, reserved to vary specifications and design without notice. Understand that the product you purchased and its contents including specifications described in this manual may differ.

REQUEST

If you find inaccuracies or errors in this manual, advise distributor or the nearest Service office.

LIMITED WARRANTY

This WARRANTY applies to the customer to whom BOC Edwards has delivered this product.

1. **WARRANTY PERIOD:**

BOC Edwards warrants this product against defects for a period of two (2) years from the date of delivery or during the period specified in the agreement made by and between the customer and BOC Edwards.

2. **ITEM WARRANTED:**

- 1) This warranty applies only to the product delivered from BOC Edwards to the customer.
- 2) If any defect is found during this period, BOC Edwards will, at its option, repair or recondition the product free of charge. The costs for repair or replacement of the product after the warranty period has passed will be at the customer's own charge.

3. **DISCLAIMER:**

BOC Edwards makes no warranty with respect to any damage occurred due to any of the following during the warranty period:

- 1) Handling, operation or maintenance other than that specified herein;
- 2) Failure to follow any of the warnings or cautions enumerated under



- 3) Installation, operation or maintenance using parts which are not specified by BOC Edwards;
- 4) Maintenance personnel other than those authorized by BOC Edwards or service office have disassembled, reconditioned, or tampered the product;
- 5) Defect resulting from the not-specified use of the product.
- 6) When the product is used under special conditions without obtaining the written consent of BOC Edwards (Particular gases, strong magnetic field and the radiation are added to the product.);
- 7) Defect resulting from deposit;
- 8) Water cooling system defect resulting from water quality used;
- 9) Defect resulting from the installation of the product (Exclude the installation by authorized personnel.)
- 10) Deterioration in the external because of use (Discoloration, scratches and so forth)
- 11) Product damage occurred during transport or other factors not attributable to BOC Edwards;
- 12) Product breakage or damage due to natural disasters, fire or other external factors;
- 13) Deterioration in the basic performance due to the use of the product beyond limits of the use;
- 14) Any direct, incidental or consequential damage resulting from the use of the product;
- 15) When continuously operated without overhaul after the WARNING indication ("WARNING" message) on the LCD display;
- 16) Overhaul and replacement of maintenance parts;

4. SPARE PARTS:

- Fuse and air cooling fan for control unit
- Touch down bearing
- Heater

TABLE of CONTENTS

SAFETY PRECAUTION

INTRODUCTION

LIMITED WARRANTY

1	Precautions for Safe Operation of the STP Pump	1-1
1.1	Usable Gases	1-1
1.2	Precautions on Maintenance and Inspection	1-1
1.3	Labels	1-2
2	Operation Principle of the STP Pump	2-1
3	Unpacking	3-1
3.1	Unpacking the STP Pump and the STP Control Unit.....	3-1
3.2	Accessories	3-1
4	Installation of the STP Pump	4-1
4.1	Name and Function of Each Part.....	4-1
4.2	Precautions Before Installation	4-3
	4.2.1 Operating Environment.....	4-3
	4.2.2 Installation Area	4-4
	4.2.3 Bench.....	4-4
4.3	How To Install the STP Pump	4-5
	4.3.1 Cleaning the Seal	4-6
	4.3.2 STP Pump Installation Positions	4-7
	4.3.3 How to Secure the STP Pump.....	4-8
	4.3.4 Vacuum Piping	4-12
	4.3.5 Connecting the Ground Cable.....	4-13
	4.3.6 Connecting the Purge Port (For the Chemical Specific Pump, Type C).....	4-14
5	Baking, Cooling the STP Pump and Gas Pumping	5-1
5.1	Baking the STP Pump	5-1
	5.1.1 Attaching a Baking Heater	5-1
5.2	Cooling the STP Pump	5-2
	5.2.1 Water Cooling Method.....	5-2
	5.2.2 Air Cooling Method.....	5-3
5.3	Gas Suction	5-4
	5.3.1 How to Introduce a Purge Gas [For Chemical Specific Pump (Type C)].....	5-4
6	Installation of the STP Control Unit.....	6-1
6.1	Name and Function of Each Part.....	6-1
	6.1.1 Front Panel.....	6-1
	6.1.2 Rear Panel.....	6-3
	6.1.3 Top Panel	6-5
	6.1.4 Side Panel (Left)	6-6
6.2	Precautions Before Installation	6-7

6.2.1	Operating Environment.....	6-7
6.2.2	Insulation Test.....	6-7
6.2.3	Installation Area	6-8
6.3	Attaching the STP Control Unit Front Panel to a Rack.....	6-9
6.4	Cable Connection	6-10
6.4.1	Name and Dimensions of Each Cable	6-10
6.4.2	How to Connect the Cables	6-12
6.5	Connecting to Semiconductor Equipment.....	6-14
6.5.1	Connecting to Power	6-14
6.5.2	Emergency Off Circuit (EMO Circuit).....	6-14
7	How to Start/Stop the STP Pump	7-1
7.1	Before Starting.....	7-1
7.2	Start Procedures.....	7-2
7.3	Stop Procedures	7-2
7.4	Manual Operation.....	7-3
7.4.1	Powering ON.....	7-3
7.4.2	Starting the STP Pump.....	7-3
7.4.3	Stopping the STP Pump.....	7-3
7.4.4	Starting the STP Pump after Stopping.....	7-4
7.4.5	Powering OFF.....	7-4
7.4.6	Starting the STP Pump after a Safety Function Operates.....	7-4
7.5	Remote Operation (I/O TB2)	7-5
7.5.1	Powering ON.....	7-5
7.5.2	Starting/Stopping the STP Pump.....	7-5
7.5.3	Starting the STP Pump After Stopping	7-6
7.5.4	Powering OFF.....	7-6
7.5.5	Starting the STP Pump after a Safety Function Operates.....	7-6
7.6	Remote Operation (CON4: Optional Accessory)	7-7
7.6.1	Powering ON.....	7-7
7.6.2	Starting/Stopping the STP Pump.....	7-7
7.6.3	Starting the STP Pump After Stopping	7-8
7.6.4	Powering OFF.....	7-8
7.6.5	Starting the STP Pump after a Safety Function Operates.....	7-8
8	Remote Input/Output Signal Terminal Blocks	8-1
8.1	I/O TB1 Terminal Block.....	8-1
8.2	I/O TB2 Terminal Block	8-5
8.3	CON4 Connector (Optional accessory)	8-7
8.3.1	Remote Input Signals.....	8-7
8.3.2	Remote Output Signals.....	8-9
8.3.3	Remote Cables (Optional Accessories).....	8-11
9	Adjustment Method.....	9-1
9.1	Tuning	9-1
9.1.1	Tuning Method.....	9-1
9.2	Setting the Rated Speed	9-3
9.2.1	When Setting DSW-B No. 1 to ON under Power-ON State.....	9-3
9.2.2	When Setting DSW-B No. 1 to ON before Powering On.....	9-4

10	Safety Functions	10-1
10.1	Power Failure.....	10-1
10.2	Abnormal State of Magnetic Bearing	10-3
10.3	Excessive Vibration.....	10-3
10.4	Motor Driver Overload.....	10-3
10.5	Overheating Inside the STP Pump.....	10-3
10.6	Overheating Inside the STP Control Unit	10-3
10.7	Overspeed.....	10-3
11	Troubleshooting, Maintenance and Inspection	11-1
11.1	Troubleshooting Immediately After An Abnormality/Error Occurs	11-1
	11.1.1 In Case of a Power Failure:	11-1
	11.1.2 In Other Cases	11-1
11.2	When Error Message is Displayed.....	11-2
	11.2.1 Error Messages	11-2
	11.2.2 Displaying Past Abnormalities/Errors and Accumulated Running-Time	11-5
	11.2.3 Abnormalities When Powering ON.....	11-7
	11.2.4 Abnormalities When Performing the STP Pump Start Operation	11-7
	11.2.5 Other Abnormalities	11-8
11.3	Maintenance and Inspection	11-9
	11.3.1 Inspecting the Air Cooling Fan	11-9
	11.3.2 Replacing the Fuses	11-10
	11.3.3 Cleaning and Decontamination.....	11-11
	11.3.4 Inspecting for Deposit.....	11-11
	11.3.5 Overhaul	11-12
	11.3.6 Transporting for Repair or Overhaul.....	11-13
12	Storage and Disposal	12-1
12.1	Storage of the STP Pump.....	12-1
12.2	Storage of the STP Control Unit	12-1
12.3	Disposal	12-2
13	Specifications and Accessories.....	13-1
13.1	Specifications of the STP Pump.....	13-1
13.2	Specifications of the STP Control Unit	13-6

UNIT CONVERSION TABLE

ANNEX

MALFUNCTION INFORMATION

STP Series / Global Service Network

TABLES

Table 3.1	Accessories	3-1
Table 3.2	Accessories for Chemical Specific Pump (Type C).....	3-1
Table 4.1	Tightening torque of bolt	4-8
Table 4.2	Maximum Torque predicted and Recommended securing bolt for inlet port flange.....	4-9
Table 4.3	Number of Claw Clamps by Size of Flange	4-10
Table 6.1	Connecting the Power Cable	6-13
Table 7.1	Starting/Stopping the STP Pump during Remote Operation (I/O TB2).....	7-5
Table 7.2	Reset Operation during Remote Operation (I/O TB2)	7-6
Table 7.3	Starting/Stopping the STP Pump during Remote Operation (CON4)	7-7
Table 7.4	Reset Operation during Remote Operation (CON4)	7-8
Table 8.1	I/O TB1 Terminal Block	8-1
Table 8.2	Rated Contacts for Relays CR1, 3, 5, 7, and 8.....	8-4
Table 8.3	Rated Contacts for Relays CR4 and 6.....	8-4
Table 8.4	I/O TB2 Terminal Block	8-5
Table 8.5	CON4 Connector (Remote Input Signal)	8-7
Table 8.6	Rated Coils for Relays CR1, 2 and 3.....	8-8
Table 8.7	CON 4 Connector (Remote output signal).....	8-9
Table 8.8	Rated Contacts for Relays CR4, 5, 6, 7, 8, 9 and 10.....	8-11
Table 8.9	Remote Cable Connections (Single-Side Connector Type).....	8-11
Table 10.1	States of Lamps and REMOTE Output Signals at Power Failure	10-2
Table 10.2	Operations of the STP Pump after Power Recovery	10-2
Table 10.3	Safety Functions.....	10-4
Table 11.1	Error Messages	11-3
Table 11.2	Troubleshooting after Powering ON.....	11-7
Table 11.3	Troubleshooting When Performing the STP Pump Start Operation	11-7
Table 11.4	Troubleshooting While the STP Pump is Rotating.....	11-8
Table 11.5	Recommended Spare Parts	11-10
Table 11.6	Cleaning and Decontamination.....	11-11
Table 13.1	Specifications of the STP Pump.....	13-1
Table 13.2	Specifications of the STP Control Unit	13-6

FIGURES

Figure 2.1	Cross Sectional View of the STP Pump	2-2
Figure 4.1	Configuration of the STP Pump	4-2
Figure 4.2	Installation of the STP Pump to the Vacuum Equipment	4-5
Figure 4.3	STP Pump Installation Positions	4-7
Figure 4.4	Positions of the Outlet Port on the Horizontally or Slanted Installed STP Pump	4-7
Figure 4.5	Example of securing the STP pump (When securing the inlet port with bolts)	4-9
Figure 4.6	Example of securing the STP pump (When securing the inlet port flange with claw clamps)	4-10
Figure 4.7	Example of securing the STP pump (When installing the damper in the inlet port flange)	4-11
Figure 4.8	Connecting the Purge Port	4-14
Figure 5.1	Attaching Positions of the Cooling Unit and Baking Heater	5-5
Figure 6.1	STP Control Unit Front Panel	6-2
Figure 6.2	STP Control Unit Rear Panel	6-4
Figure 6.3	STP Control Unit Top Panel	6-5
Figure 6.4	STP Control Unit Side Panel (Left)	6-6
Figure 6.5	Peripheral Spaces of the STP Control Unit	6-8
Figure 6.6	Example of Securing the STP Control Unit	6-9
Figure 6.7	External Dimensions of Ground Cable	6-10
Figure 6.8	External Dimensions of STP Connection Cable	6-10
Figure 6.9	External Dimensions of STP Connection Cable	6-11
Figure 6.10	How to Secure the Power Cable	6-13
Figure 7.1	STP Pump Operation Procedures	7-9
Figure 8.1	I/O TB1 Remote Output Signal Terminal Block	8-3
Figure 8.2	I/O TB2 Remote Input Signal Terminal Block	8-6
Figure 8.3	CON4 Remote Input Signal Connector	8-8
Figure 8.4	CON4 Remote Output Signal Connector	8-10
Figure 9.1	Tuning Procedures	9-2
Figure 9.2	LCD Message in Rated Speed Setting Mode	9-5
Figure 13.1	External Appearance of the STP Pump [without Anti-Corrosion Treatment] (Example: STP-301)	13-2
Figure 13.2	External Appearance of the STP Pump [Chemical Specific Type C] (Example: STP-301C)	13-3
Figure 13.3	Label Affixing Position for the STP Pump	13-4
Figure 13.4	Label Affixing Positions for the Optional Accessories	13-5
Figure 13.5	External Appearance of the the STP Control Unit	13-8
Figure 13.6	Label Affixing Positions for the STP Control Unit	13-9

1 Precautions for Safe Operation of the STP Pump

1.1 Usable Gases

Chlorine or fluorine system gases can be used in chemical specific pumps (STP-301C/STP-451C or other models). When you use gases including alkaline metals, but excluding Li, gases including Ga, Hg, In, or Sn, or HBr, contact BOC Edwards.



To prevent an accident, confirm the characteristics of gases to be used, referring to the Material Safety Data Sheet (MSDS) you obtain from the gas supplier.

And, keep MSDS and a safety advice of gas supplier.



NEVER use corrosive gases (chlorine, fluorine, or other system gases) in the STP-301/STP-451 pump or other models without anti-corrosion treatment. Introduce a dry N₂ gas (purge gas) to protect the inside of the STP pump when using reactive or corrosive gases.

Cool the STP pump to prevent the STP pump from overheating when pumping gases.

1.2 Precautions on Maintenance and Inspection

Read through Section 11, "Troubleshooting, Maintenance and Inspection" before performing any maintenance or inspection of the STP pump or the STP control unit (such as fuse replacement).



Always turn OFF the primary power (switch the breaker "OFF") before performing any maintenance.

NEVER touch any portions other than those designated when performing maintenance.

Careless touch may cause electric shock and/or a short-circuiting of the internal circuit, resulting in product damage or a problem.

1.3 Labels

The following labels are affixed to the STP pump and STP control unit. Read the contents of the labels before operation.

1) STP Pump Caution Label

This label indicates precautions for operating the STP pump. Follow these precautions.

⚠ 注意	⚠ CAUTION
<ul style="list-style-type: none"> ◇必ず指定の型式のケーブルを使用してください。 ◇最初にアース線を接続してください。 	<ul style="list-style-type: none"> ◇Use only designated type of cables. ◇Connect ground cable first.

2) STP Control Unit Caution Label

This label indicates precautions for operating the STP control unit. Follow these precautions.

⚠ 注意	⚠ CAUTION
<ul style="list-style-type: none"> ◇ポンプとコントロールユニットを異なる形の組合せで使用する場合は、接続ケーブル長を変更する場合は取扱説明書に従い調整を行ってください。 ◇必ず指定の型式のケーブルを使用してください。 ◇最初にアース線を接続してください。 	<ul style="list-style-type: none"> ◇Adjust installation according to instruction manual, if pump and control unit have different serial number or you change connection cable length. ◇Use only designated type of cables. ◇Connect ground cable first.

3) STP Pump Installation Warning Label

This label indicates the installation of the STP pump. Install the STP pump according to the precautions in Section 4, "Installing the STP Pump."

⚠ 警告	⚠ WARNING
<p>ポンプは取扱説明書の指示に従い確実に固定してください。</p>	<p>Install pump securely according to instruction manual.</p>

4) Connector Caution Label

- i. This label indicates the lock of the connector
- ii. This label instructs operators to prevent the connectors from being disconnected while the STP pump is in operation.

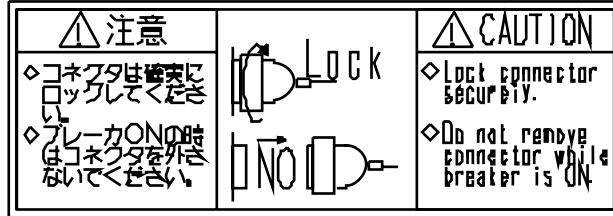

5) STP Control Unit Safety Instruction Label

This label indicates instructions before operating the STP control unit.

安全上の指示事項	SAFETY INSTRUCTIONS
使用前に取扱説明書をお読みください。	Read instruction manual before operation.

6) High Voltage Device Caution Label

The STP control unit is equipped with a high voltage device. This label warns operators to pay attention to the high voltage device.

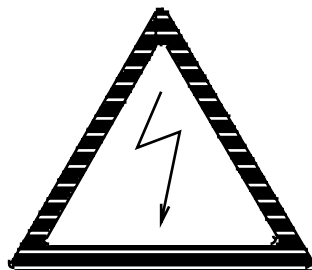

7) Rotational Direction Instruction Label

This label indicates the rotational direction of the STP pump. The STP pump rotates in this direction.



8) Voltage Rating Label

This label indicates the rated voltage of the STP control unit.
Use voltage specified in this label.



200 V specification

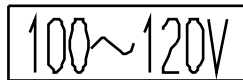

100 V specification

9) Hot Surface Warning Label

This label instructs operators so as not to touch the hot surface of the STP pump.

The use of the baking heater (optional accessory) may lead to a considerable rise in temperatures outside the STP pump.

This label warns operators so as not to burn hands.(only when using the baking heater.)

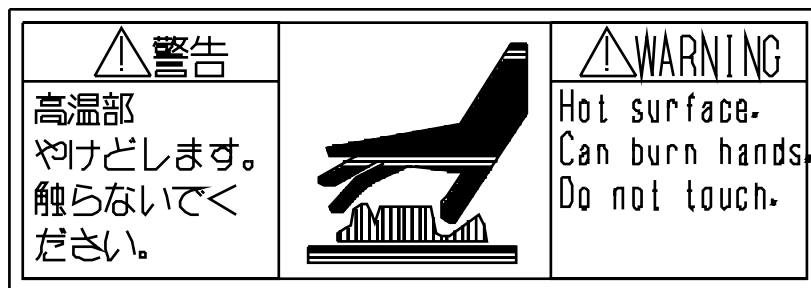

2 Operation Principle of the STP Pump

The STP-301/451 is a series of magnetically-levitated turbomolecular pumps, featuring the following:

- Oil free
- Low vibration
- High reliability

The STP pump is configured so that rotor blade (1) and stator blade (2) are aligned alternately in the axial direction. Gas molecules are pumped from the inlet port to the outlet port by the high speed rotation of the rotor.

Rotor blade (1) is supported by the magnetic bearing without mechanical contact. Therefore the STP pump requires no lubrication oil unlike conventional turbomolecular pumps using ball bearings.

The magnetic bearing consists of 3 pairs of active magnetic bearings. The rotor is supported in the radial direction by 2 pairs of radial direction active magnetic bearings that consist of radial sensor (3) and radial electromagnet (4). A pair of axial direction active magnetic bearings consists of axial sensor (5) and axial electromagnet (6) to support the rotor in the axial direction. Because the rotor is thus supported without mechanical contact, it can rotate with low vibration.

There is less heat generated from magnetic bearings because there is no friction. Therefore the STP pump requires no cooling. However, the STP pump requires water cooling or air cooling during baking and gas pumping.

Taking into consideration a breakage of magnetic bearings, touch down bearings (7) and (8) coated with solid lubrication have been installed. They do not contact the rotor during the rated operation.

A radial sensor, an axial sensor, a rotational speed sensor and a temperature sensor always monitor the magnetic bearing as well as the rotor. If an abnormality/error occurs, the rotor will stop.

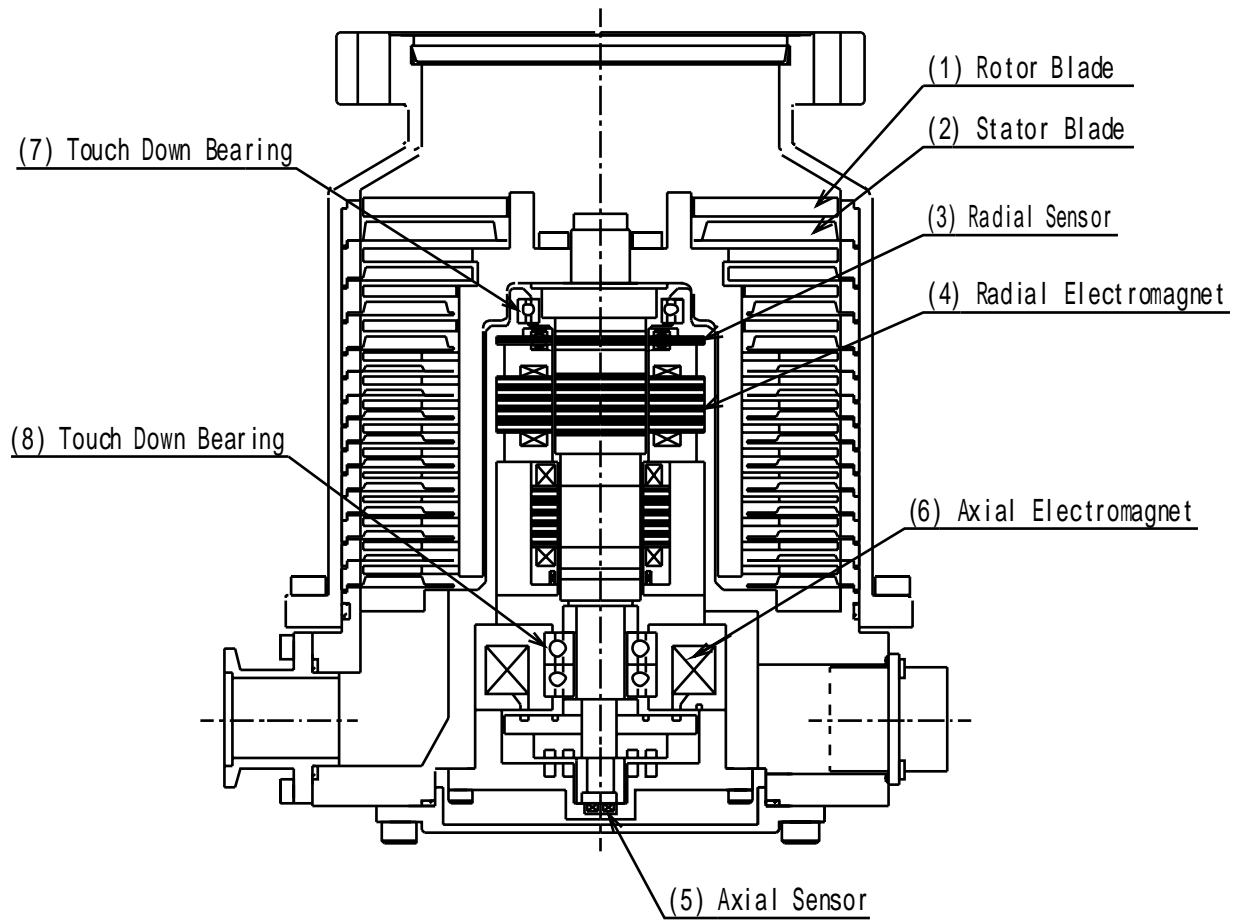

Figure 2.1 Cross Sectional View of the STP Pump

3 Unpacking

3.1 Unpacking the STP Pump and the STP Control Unit

Check the following before unpacking the STP pump and STP control unit.

- 1) Check the package for bruises, breakage, wetness, and other.
If there is any abnormality/error or it is judged necessary to return the product, contact BOC Edwards or the selling agency.
- 2) Check the contents of the package.
See Section 3.2, "Accessories."



Be careful not to scratch the flange of the STP pump.
Before installing the STP pump, check whether or not there are scratches on the surface.
It is recommended to keep the packaging materials, such as the corrugated fiberboard container and cushioning material for possible reuse.

3.2 Accessories

Table 3.1 Accessories

Item	Q'ty	Remarks
STP control unit	1	
Primary power cable *1	1	With a single-side connector
STP connection cable *1	1	With both-side connectors
Ground cable *1	1	With both-side crimp-type terminal lugs
Inlet port cover	1	
Outlet port cover	1	
STP connector cover	1	
Spare fuses 250V, 10A	2	F1, F2 (rear panel)
Instruction Manual	1	

The accessories listed below are supplied to the chemical specific pump (type C) in addition to the accessories in Table 3.1.

Table 3.2 Accessories for Chemical Specific Pump (Type C)

Item	Q'ty	Remarks
Blank flange for purge port	1	KF *2 10
Clamping ring for purge port	1	KF *2 10
O-ring washer for purge port	1	KF *2 10

*1 : The standard cable length is 3 m.

*2: JIS

4 Installation of the STP Pump

4.1 Name and Function of Each Part

- (1) Inlet Port Flange (ICF*¹, VG*¹, ISO, and other)
 - Connected to the vacuum equipment (at the high vacuum side).
- (2) Outlet Port Flange (KF*² 25)
 - Connected to the inlet port side of the backing pump.
- (3) STP Connector (41 pins)
 - Connected to the STP connection cable.
- (4) Ground Terminal
 - Used for grounding.
Connect the ground cable between this terminal and the ground terminal of the STP control unit.
The ground terminal is marked with  label.
- (5) Purge Port (KF*² 10)[Chemical Specific Pump (Type C)]
 - Introduces a purge gas.
This port is attached only to the chemical specific pump (type C). In order to protect the inside of the STP pump when pumping reactive or corrosive gases. The STP pump is delivered with a blank flange attached to this port.

*¹: JVIA Standard

*²: JIS

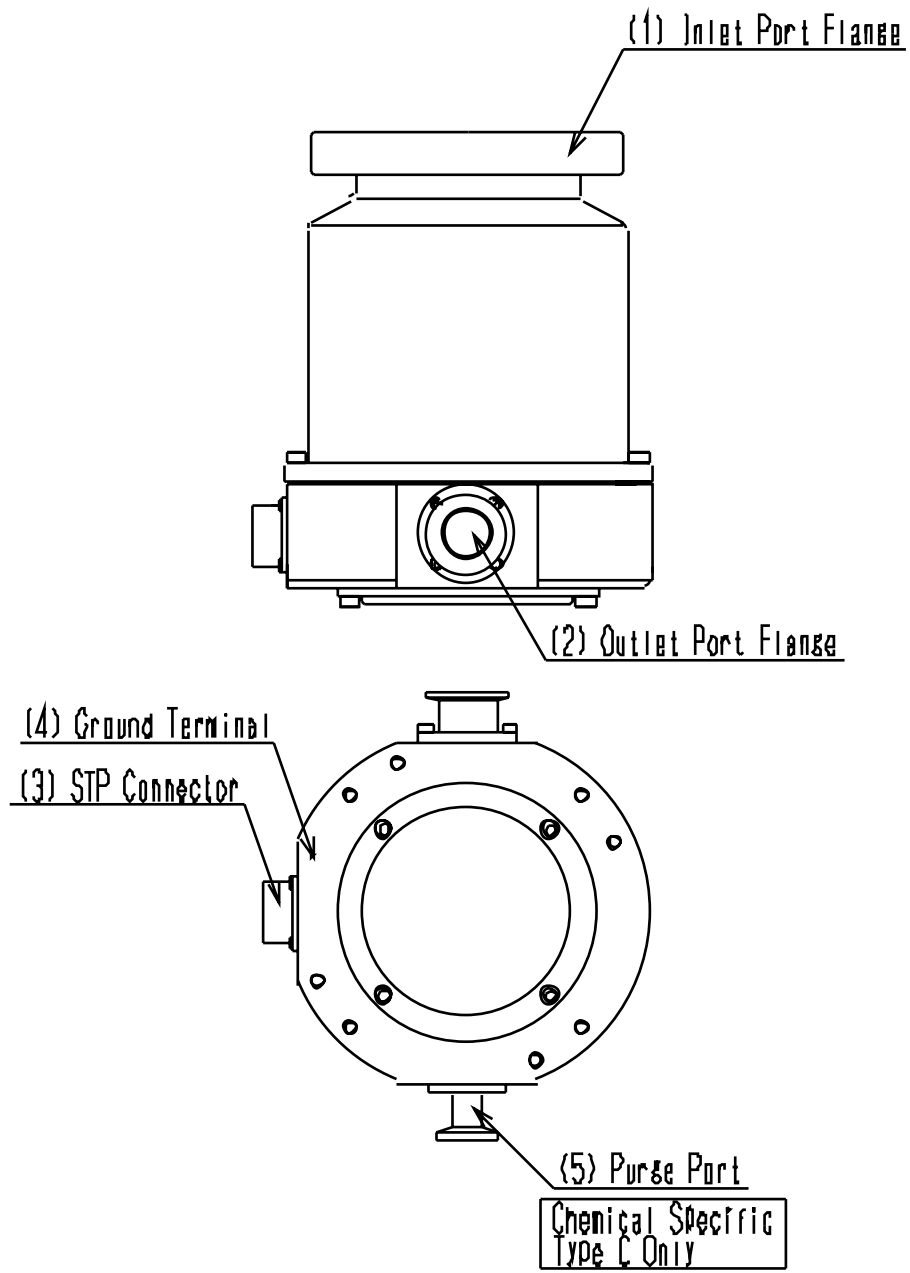

Figure 4.1 Configuration of the STP Pump

4.2 Precautions Before Installation

4.2.1 Operating Environment



Check the properties of the gas to be used, referring to the Material Safety Data Sheet (MSDS) you obtain from the gas supplier. And, keep MSDS and a safety advice of gas supplier.

Take measures according to MSDS to prevent an accident when using toxic, reactive or combustible gases. Dilute the gas to be used with the inert gas controlled if necessary. And, take measures according to MSDS to prevent an accident caused by exhaust gas.



Chlorine or fluorine system gases can be used only in chemical specific pumps (type C). When you use gases including alkaline metals, but excluding Li, gases including Ga, Hg, Sn, or HBr, contact BOC Edwards.

NEVER use corrosive gases (chlorine, fluorine, or other system gases) in the STP-301/STP-451 pump or other models without anti-corrosion treatment.

If the STP pump is used in an area with radiation, contact BOC Edwards.

Install the STP pump in a place meeting the following requirements:

Ambient Temperature	0 to 40 °C
Ambient Relative Humidity	30 to 95 % (no dew condensing)
Environment	<ul style="list-style-type: none"> ● A place free of externally-applied mechanical shock. ● A place free of a heat source (Keep clear of the heat source or attach a thermal shield plate). ● A place free of a strong magnetic field (Range: up to 15 mT (150 G) in the axial direction, and up to 3 mT (30 G) in the radial direction with respect to the rotational axis of the STP pump). ● A place free of a strong electric field. ● A place free of exposure to radiation. ● No discharge of high voltage (more than 500V) (If more than 500 V is discharged, contact BOC Edwards.)
STP Pump Installation Equipment Conditions	<ul style="list-style-type: none"> ● Install the STP pump securely so that foreign particles will easily fall into the STP pump (Ex.: Si wafers or samples are positioned above the STP pump). (To prevent foreign particles from falling into the STP pump, design a shield plate with large conductance.)

STP-301/451 Series Instruction Manual

4.2.2 Installation Area

Leave enough spaces for the following in addition to the space for the STP pump:

- Space for maintenance and inspection
- Space for connecting cables



The minimum bending radius of the STP connection cable is 150 mm (see Section 13, "External Appearance of the STP Pump" [bending dimensions of the STP connection cable]).

DO NOT excessively bend the cables and beware of any obstacles when installing the STP pump.

Also, leave enough space to install other cables without bending them excessively.



The L-type STP connection cable is also offered. Contact BOC Edwards if necessary.

4.2.3 Bench

A bench must be prepared by the customer to secure the STP pump. The shape and size of the bench differ depending upon the type of STP pump. Follow the precautions of the WARNING, CAUTION, or NOTICE (see Section 4.3.3, "How to Secure the STP Pump").



The STP pump is provided with a high-speed rotor. Any internal abnormality/error may result in a jump in rotational torque leading to personal injury or peripheral equipment damage.

Design and secure the bench for the STP pump so that it can withstand the maximum torque generated due to the occurrence of an abnormality/error. Refer to Section 4.3.3 "How to Secure the STP Pump" for abnormal torque.



Secure the customer-prepared bench and the vacuum equipment on the floor or peripheral equipment and other equipment in accordance with the customer application. NEVER move them while the STP pump is in operation.



Confirm the dimensions by the external appearance of the STP pump when designing the bench.

The bolt may not be able to be inserted from the lower side of the inlet port according to the shape of the inlet port flange.

When the external appearance of the STP pump is not in the manual, contact BOC Edwards.

STP-301/451 Series Instruction Manual

4.3 How To Install the STP Pump

Install the STP pump to the vacuum equipment as shown in Figure 4.2.

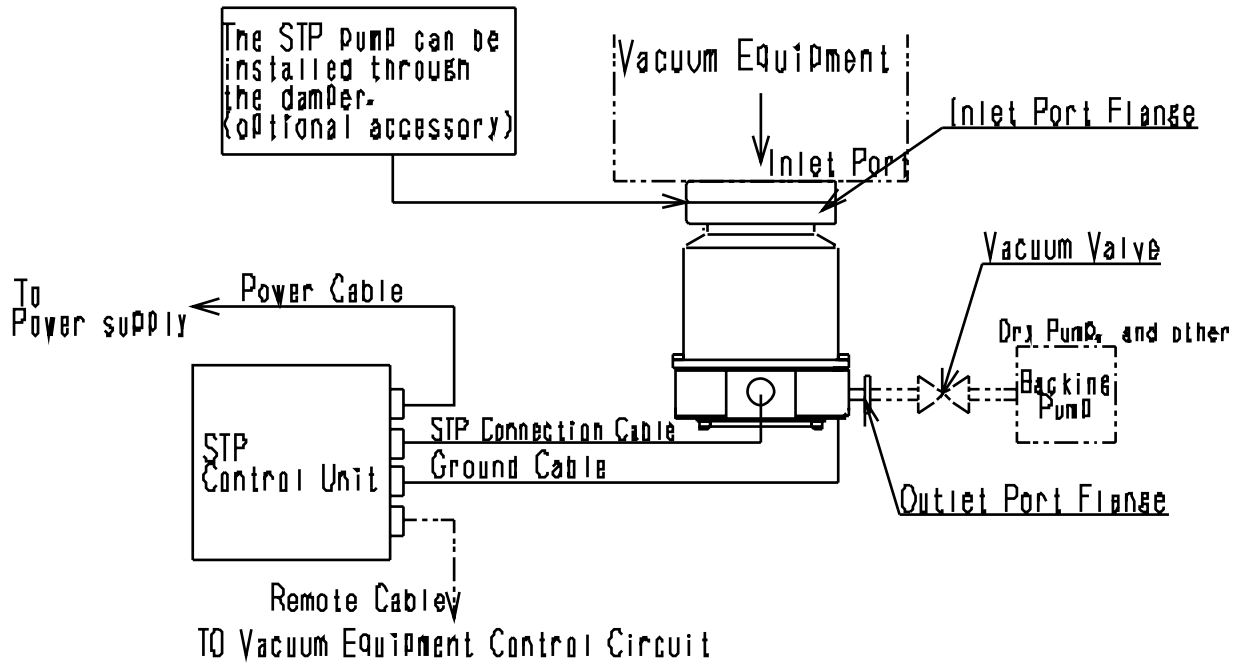

Figure 4.2 Installation of the STP Pump to the Vacuum Equipment

4.3.1 Cleaning the Seal

Inspect the seals of the inlet and outlet port flanges for dirt or oil spots before installing the STP pump to the vacuum equipment.

Take the following measures for cleaning the seals:

- Clean off with a pure gas.
- Wipe with proper solvent (such as alcohol).



A splinter shield is attached to the inlet port flange to prevent foreign particles from falling into the STP pump.

Always leave the splinter shield attached during operation.

The wipes used for clean the flange of the pump might become hazardous waste depending upon the solvent (alcohol). Dispose of the contaminated wipes appropriately according to the regulations of each national and/or local government.



The splinter shield cannot perfectly prevent foreign particles from falling into the STP pump.

DO NOT install the STP pump in such a manner that foreign particles can easily fall into it (for example, Si wafers or samples are positioned above the STP pump). If installing the STP pump in such a manner, always attach a shield plate with sufficient conductance above the STP pump to prevent foreign particles from falling into it. Foreign particles falling into the STP pump through the splinter shield may result in product damage.

Be careful not to scratch the flange of the STP pump.

Check whether or not there are scratches on the surface, before installing the STP pump.

STP-301/451 Series Instruction Manual

4.3.2 STP Pump Installation Positions

The STP pump can be installed vertically, horizontally, and upside-down and slanted.

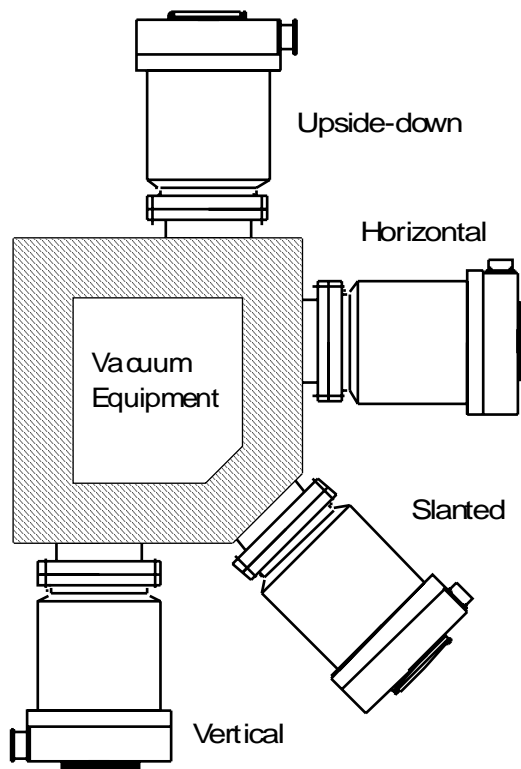

Figure 4.3 STP Pump Installation Positions

When installing the STP pump in a horizontal or slanted position, it is recommended to install it so that the direction of the outlet port is on a vertical or horizontal plane in the direction of the gravity.

This makes it possible to reduce the load on the magnetic bearing and the heat generated by the STP pump.

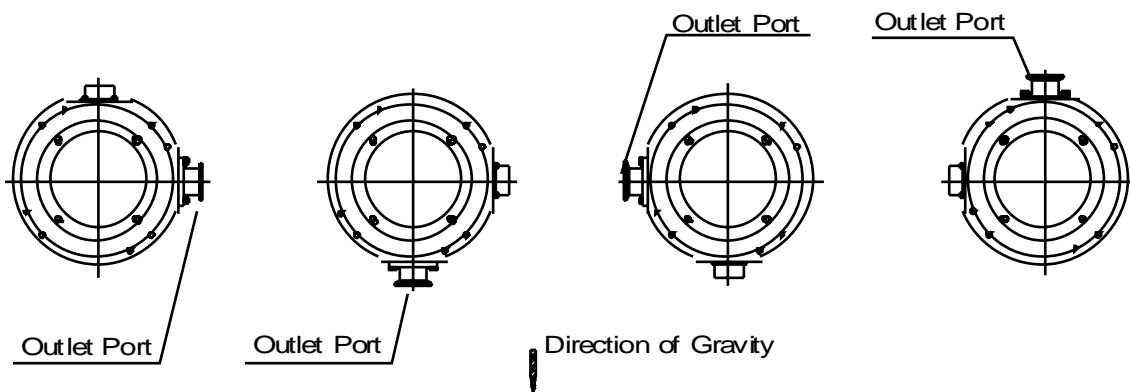

Figure 4.4 Positions of the Outlet Port on the Horizontally or Slanted Installed STP Pump

4.3.3 How to Secure the STP Pump



The STP pump is provided with a high-speed rotor. The worst-case failure may result in a jump in rotational torque leading to personal injury or peripheral equipment damage.

The method of securing the STP pump will depend on the installation requirements. Secure the STP pump to the vacuum equipment as follows: Design and secure the mounting for the STP pump so that it can withstand the maximum rotational torque. Refer to Table 4.2 for torque in pump abnormality.

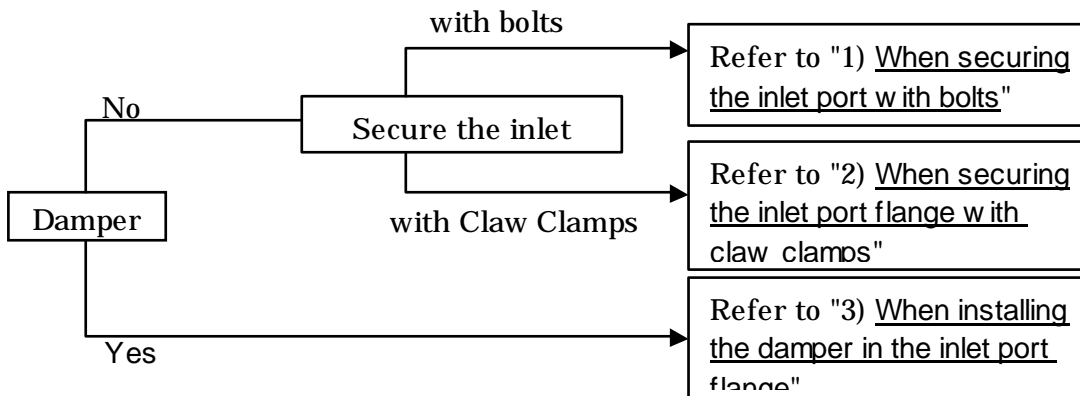

In some cases, the damper and the claw clamping securing cannot be used depend on the type of the STP pump.

Refer to Table 4.1 for tightening torque of the bolt.

Table 4.1 Tightening torque of bolt

Size of bolt	Tightening torque of bolt (Nm)
M8	12.0
M10	24.1
M12	42.1

When making the leg to secure the base, make them shortened more than ones attached to the STP pump.

Use a material that has a tensile strength of 600N/mm² or more.

When securing the base, use stainless steel securing bolts with a tensile strength class is 70 or more.



When using any securing method other than that specified in this manual, contact BOC Edwards.

STP-301/451 Series Instruction Manual

1) When securing the inlet port with bolts

Refer to Table 4.2 for torque in pump abnormality and recommended securing bolts.

Secure the inlet port flange with all of the boltholes of the size specified in the Inlet Port Flange Standard.

Secure the base with all 8 screw-holes for legs or all 8 attached legs.

Follow "CAUTION" on page 4-9 about legs and bolts for securing the base.

Make sure that the recommended securing bolt may be different depending on the method of securing the base.

Table 4.2 Maximum Torque predicted and Recommended securing bolt for inlet port flange

Model of TMP		STP-301					
Type of flange		VG100		ISO100F/ISO100		ICF152	
Torque in pump abnormality [Nm]		3.8×10 ³		3.8×10 ³		3.8×10 ³	
Base(8 positions)securing		No	Yes	No	Yes	No	Yes
Recommended securing bolt for TMP Flange	Type of bolt	Standard					
	Type of steel* ¹	Stainless steel					
	Strength * ¹	70 or more					

Model of TMP		STP-451					
Type of flange		VG150		ISO160F/ISO160		ICF203	
Torque in pump abnormality [Nm]		3.8×10 ³		3.8×10 ³		3.8×10 ³	
Base(8 positions)securing		No	Yes	No	Yes	No	Yes
Recommended securing bolt for T	Type of bolt	Standard					
	Type of steel * ¹	Stainless steel					

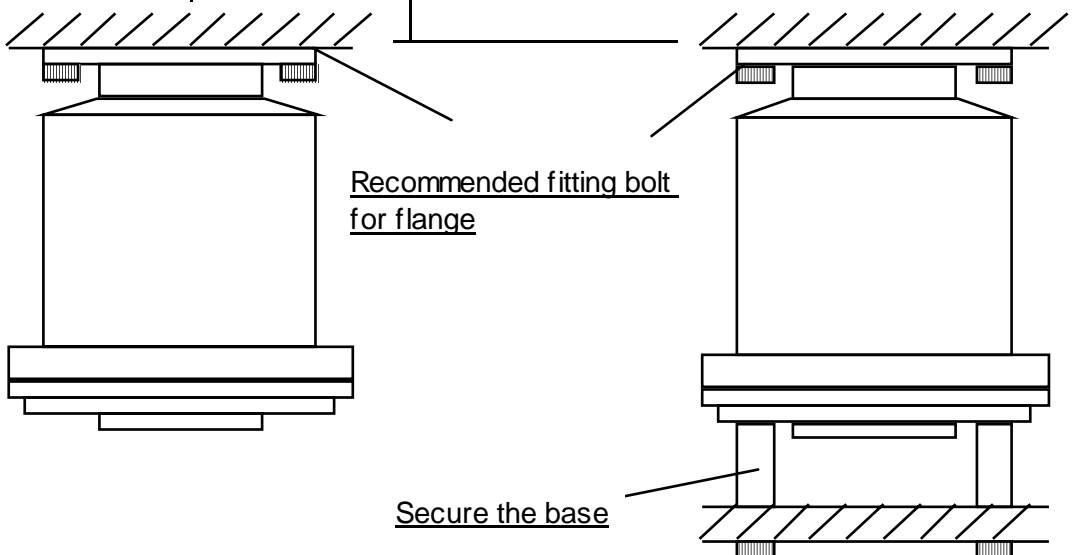

(a) When the base is not secured

(b) When the base is secured

Figure 4.5 Example of securing the STP pump (When securing the inlet port with bolts)

*¹: Refer to ISO898-1(JISB1051), ISO3506(JISB1054) and AMS6419(Aerospace Material Specification)

2) When securing the inlet port flange with claw clamps

Refer to Table 4.2 for rotational torque.

When securing the inlet port flange with only the claw clamp, the vacuum equipment cannot withstand the maximum rotational torque generated by the worst-case failure. To make the vacuum equipment withstand abnormal torque, secure the base with all 8 screw-holes for legs or all 8 attached legs. Follow "CAUTION" on page 4-9 about legs and bolts for securing the base. For the claw clamp-type, use the required number of claw clamps as specified in Table 4.3. Position the claw clamps evenly on the circumference.

Table 4.3 Number of Claw Clamps by Size of Flange

Size of Flange	Number of Claw Clamps
ISO 160 or less	4 or more
ISO 200 to 250	6 or more
ISO 320 or more	8 or more

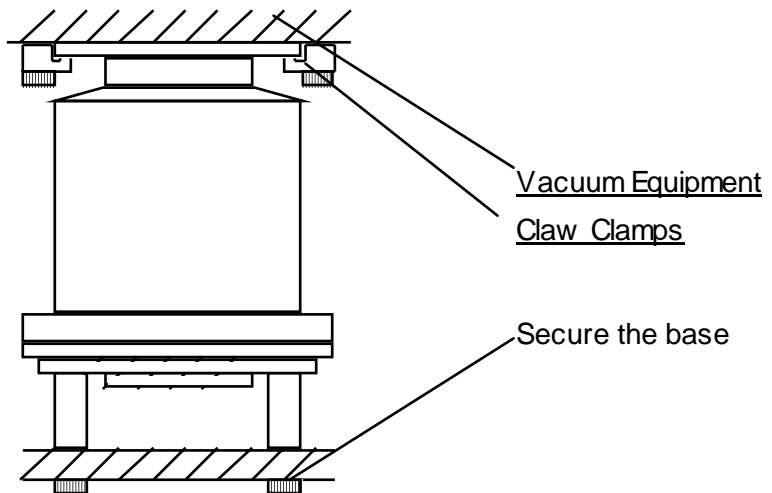

Figure 4.6 Example of securing the STP pump (When securing the inlet port flange with claw clamps)

STP-301/451 Series Instruction Manual

3) When installing the damper in the inlet port flange

Refer to Table 4.2 for rotational torque.

In case of using a damper, secure the base with all 8 screw-holes for legs or all 8 attached legs. Follow "CAUTION" on page 4-9 about legs and bolts for securing the base.

When the base cannot be secured because of the equipment design, install the pump with a torque restraint like the one shown in Figure 4.7 (b).



Use a damper only at the vertically upright position.

DO NOT remove the bolts and nuts attached to reinforce the damper.

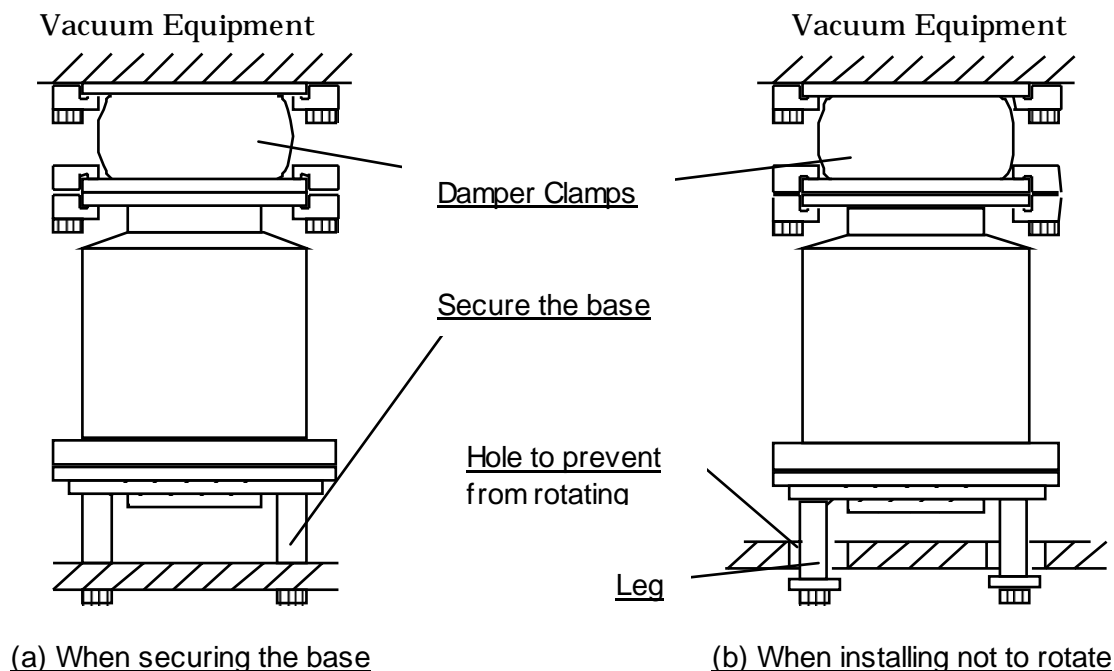

Figure 4.7 Example of securing the STP pump
(When installing the damper in the inlet port flange)

4.3.4 Vacuum Piping



DO NOT open the STP pump through the flange to atmospheric air while the STP pump is running.

If atmospheric air flows into the STP pump, it may not function normally.

Depending upon the type of the backing pump used, atmospheric air may reverse flow into the STP pump when the backing pump stops.

Attach a vacuum valve to the middle of the piping between the STP pump outlet port flange and the backing pump, and close the vacuum valve when the backing pump stops.

In order to let the STP pump bring its performance into full play, follow the precautions below:

- 1) Be careful not to scratch the flange of the STP pump.
Before installing the STP pump, check whether or not there are scratches on the surface.
- 2) Use steel or aluminum tubes with a low gas loss to connect the vacuum equipment to the STP pump.
- 3) Take measures for minimizing leakage. It is also necessary to degrease the tubes as regularly as possible to keep the gas loss as low as possible.
- 4) It is recommended to use an backing pump of pumping speed 240 L/min or more. However, the pressure at the inlet and outlet ports varies with the flow rate of gas, capacity of the vacuum equipment, length and material of the piping. Select an backing pump in accordance with the capacity and starting method (simultaneous starting, starting after generating roughing vacuum) suitable for the vacuum equipment you use.
- 5) Connect the STP pump and the backing pump using stainless steel or aluminum alloy tubing, flexible tubing, vacuum rubber or Teflon tubing, and other.
The following measures can be used to avoid the transmission of the vibration of the backing pump to the STP pump and the vacuum equipment.
 - DO NOT place the backing pump on the same floor as the vacuum equipment.
 - Locate the backing pump on a vibration-proof table.
Attain 1/3 or less of the rotational speed of the backing pump, when adjusting the inherent frequency of the backing pump installed on a vibration-proof table.
 - Attach a weight to the piping from the backing pump, or secure the piping to a rigid, heavy object free of vibration.
 - Use a tube of high flexibility.
- 6) Depending upon the type of the backing pump used, oil may contaminate the inside of the STP pump. Some oil viscosity could cause a malfunction when there is a strong reverse flow of oil.
Take the following measures to ensure the correct flow of oil:
 - Attach a vacuum valve to the middle of the piping between the STP pump outlet port flange and the backing pump.
 - Attach an absorption trap adjacent to the vacuum valve.

STP-301/451 Series Instruction Manual

Piping at the Inlet Port Flange

Attach the inlet port to the high vacuum side.

Maximum working pressure:	6.7×10^{-2} Pa [5×10^{-4} Torr]
Pressure at the inlet port flange applicable continuously	(for natural air cooled)

Piping at the Outlet Port Flange

Attach the outlet port to the inlet port flange of the backing pump (primary side pump).

Allowable backing pressure:	13 Pa [0.1 Torr]
Pressure at the outlet port flange applicable continuously	(for natural air cooled)



To attain the ultimate pressure shown in Table 13.1, "STP Pump specifications," set the pressure at the outlet port flange to 1.3 Pa (10^{-2} Torr).

4.3.5 Connecting the Ground Cable

Connect the ground cable (yellow/green) between the ground terminal of the STP pump and the ground terminal of the STP control unit.

When the resistance between the ground terminals is lower than 0.1 ohms, it is not necessary to connect the ground cable after installing the STP pump and the STP control unit.



When the resistance between the ground terminals is over 0.1 ohms, always connect the ground cable.

4.3.6 Connecting the Purge Port (For the Chemical Specific Pump, Type C)

When pumping reactive or corrosive gases, introduce a dry N₂ gas or other gas into the STP pump in order to protect the inside of the STP pump.

As shown in Figure 4.8, introduce a dry N₂ gas through the electromagnetic vent valve, needle valve or similar valve (must be prepared by the customer) from the purge port. For instructions on how to introduce the purge gas, see Section 5.3, "Gas Suction."

NOTICE

When not introducing the purge gas, close the purge port with the blank flange (attached at delivery).

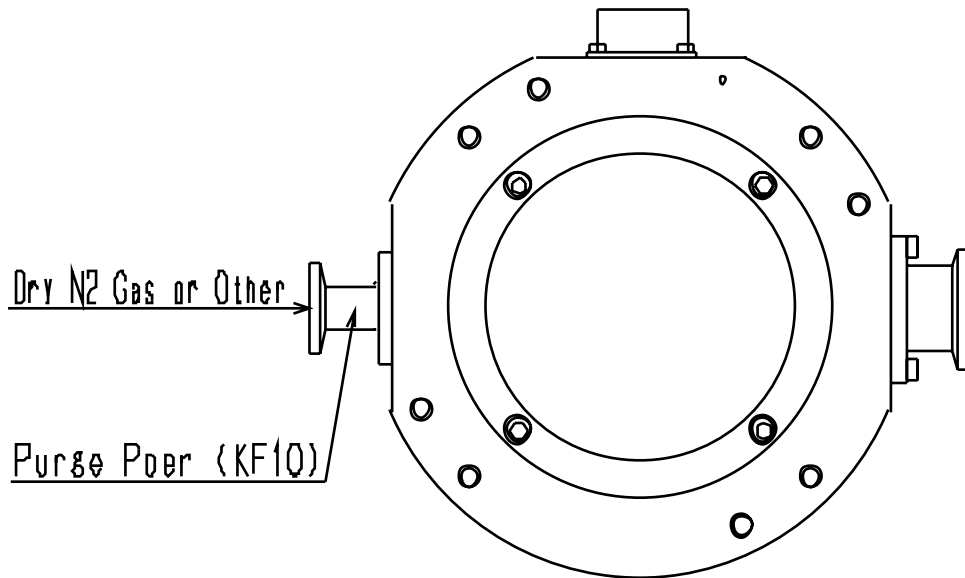

Figure 4.8 Connecting the Purge Port

5 Baking, Cooling the STP Pump and Gas Pumping

5.1 Baking the STP Pump

To attain a lower pressure in a shorter time and reduce the exhaust time, bake the vacuum equipment and STP pump.



The surfaces of the STP pump and its peripheral equipment will become extremely hot when performing baking. NEVER touch them with bare hands.



When baking the STP pump, always cool it to prevent overheating. Start baking after cooling is started. Set the temperature of the baking heater to 120 °C or lower (an optional baking heater is set to 110 °C or lower). DO NOT pump gases during baking to prevent overheating.



To exhaust the gas discharged from the vacuum equipment and the inner wall of the STP pump, run the STP pump during baking.

5.1.1 Attaching a Baking Heater

- 1) Attach a baking heater (optional accessory) as near as possible to the inlet port flange.
- 2) Affix the "Hot Surface Warning Label" to the surface of the STP pump so that the operator can see it clearly at any time.
(See Figure 5.1, "Attaching Positions of the Cooling Unit and Baking Heater")



Check the rated voltage of the baking heater before use. (The range of the available voltage of the baking heater (special accessory) is display voltage +/-10%.) Wind the baking heater around the surface of the STP pump tightly. If the baking heater is not wound tightly, the loose parts will overheat. Procure protective parts for the baking heater, such as circuit breaker and fuses when using the baking heater. DO NOT apply excessive force to the cable for the baking heater.

5.2 Cooling the STP Pump

There are two methods for cooling: Water cooling and Air cooling.

When performing baking, cool the STP pump.

Also, when pumping gases, cool the STP pump as well.

Select the best method which fits your vacuum equipment.

5.2.1 Water Cooling Method

When cooling the STP pump by water cooling, use a water cooling unit (optional accessory). Attach the water cooling unit using 4 screws at screw holes for legs (8-M8^{*1}, depth 16 mm). (For the positions of the screw holes for legs, see "External Appearance of the STP Pump.")

- 1) Connect the cooling water pipe to the cooling water port in accordance with Figure 5.1.
- 2) The female screw PT^{*1} (RC)1/4 is used in the cooling water port.
- 3) Use the connection hose of ID (internal diameter) 8 mm, and secure it to prevent water leakage.
- 4) Use cooling water under the following conditions:
 - Amount of water: 2 L/min.
 - Temperature: 5 to 25 °C
 - Water pressure: 2.9×10^5 Pa (3 kgf/cm²) or lower



Use clean water as much as possible.

Cooling water containing foreign materials may corrode or clog the cooling water pipe.

When the cooling system is clogged with foreign materials, clogs may possibly be removed by feeding cooling water reversibly.

When the STP pump is overheated due to shortage or suspension of water, the protective function detects the overheated condition in the STP pump and stops the STP pump.

As a further safety procedure, attach a flow switch to the cooling water exit so that the STP pump stops if abnormal cooling water flow occurs (a flow switch is available on the market).

When the STP pump is not to be used for a long period of time or it is to be moved after use, introduce compressed air from one side of the inlet/outlet port so that no water will remain inside.

The joint for the water cooling unit is made of brass. To prevent corrosion, connect the brass joint.

^{*1}: JIS

5.2.2 Air Cooling Method

When water cooling is not available, use an air cooling unit (optional accessory). Attach the air cooling unit using 4 screws at screw holes for legs (8-M8¹, depth 16 mm). (For the positions of the screw holes for legs, see "External Appearance of the STP Pump")



Since the air cooling unit is attached using 4 screw holes for legs, the base for securing the STP pump cannot be installed using screw holes for legs (see Section 4.3.3, "How to Secure the STP Pump"). When using the air cooling unit, design your vacuum equipment so that the STP pump installing flange at the vacuum equipment side can withstand the torque generated by the abnormal STP pump.



Check the rated voltage of the air cooling unit before use.
Procure a breaker or fuses for the air cooling unit (remote terminal block TB1 incorporates fuses).
When connecting the power for the air cooling unit to the remote terminal block (I/O TB1), attach a metallic cover or a similar part to the terminal block to ensure the safety.
DO NOT apply excessive force to the cable for the air cooling unit.

Follow the steps below to run the STP pump associated with the air cooling unit (read through Section 8, "Remote Input/Output Signal Terminal Blocks," then operate them.)

- 1) Connect the power cable of the air cooling unit between "I/O TB1 FAN OUT Terminals (3)-(4)."
- 2) Input the power supply for the air cooling unit between "I/O TB1 AC. POWER IN Terminals (1)-(2)."
- 3) The air cooling unit functions under the "ACCELERATION" or "NORMAL OPERATION" state.
- 4) The air cooling unit stops when the STP pump stops.

5.3 Gas Suction



When pumping gases, they may remain in the STP pump. Introduce a purge gas and then exhaust all gasses. Residual gases in the STP pump may cause an accident when the STP pump is removed. Confirm the characteristics of gases to be used, referring to the Material Safety Data Sheet (MSDS) you obtain from the gas supplier.



Chlorine or fluorine system gases can be used in the chemical specific pump (type C). When you use gases including alkaline metals, but excluding Li, gases including Ga, Hg, In, or Sn, or HBr, contact BOC Edwards. NEVER use corrosive gases (chlorine, fluorine, or other system gases) in the STP-301/STP-451 pump or other models without anti-corrosion treatment. Cool the STP pump to prevent the STP pump from overheating when pumping gases.

5.3.1 How to Introduce a Purge Gas [For Chemical Specific Pump (Type C)]



When pumping reactive or corrosive gases, introduce a purge gas to protect the inside of the STP pump. Doing so may result in product damage.

Connect a needle valve or a similar part to the purge port and introduce a dry N₂ gas or other gas to perform a gas purge (see Section 4.3.6, "Connecting the Purge Port").



The proper amount of the gas purge is approx. 1.7×10^{-2} Pa·m³/sec (10SCCM). The allowable gas pressure ranges from zero [atmospheric pressure] to 4.8×10^4 Pa [gauge pressure] (zero [atmospheric pressure] to 0.5 kgf/cm² [gauge pressure]). When not using the purge port, always mount the blank flange (attached at delivery). High-pressure at the inlet port may result in a noise. This is no abnormality/error.

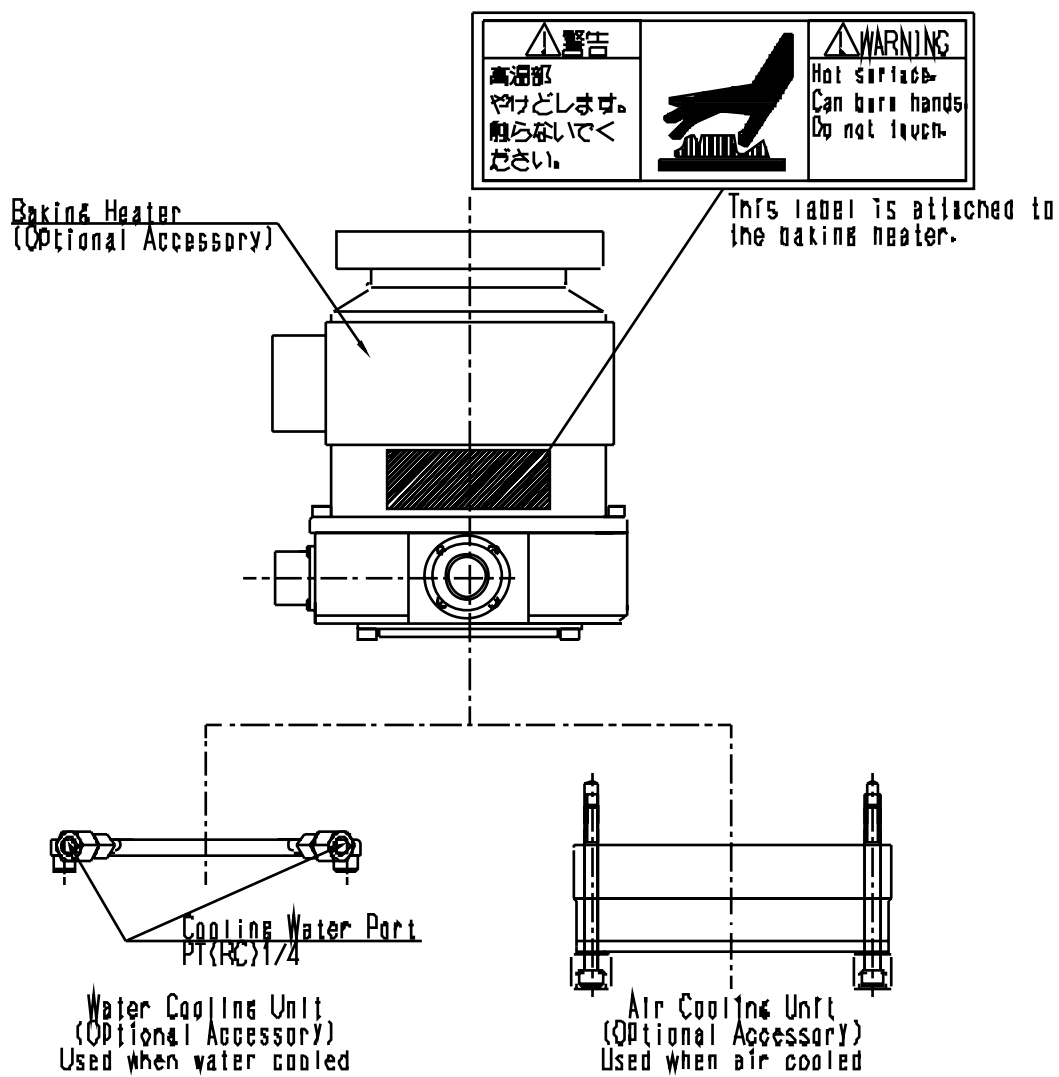

Figure 5.1 Attaching Positions of the Cooling Unit and Baking Heater

6 Installation of the STP Control Unit

6.1 Name and Function of Each Part

6.1.1 Front Panel

- (1) "START" Switch (momentary push button switch, green)
 - STP pump rotating function (valid in MANUAL operation only)
Press this switch to accelerate the STP pump when the LCD displays "LEVITATION" or "BRAKE : ***00rpm" (**00rpm indicates the current rotational speed).
The "ACCEL." lamp lights simultaneously.
 - Rated speed setting function (valid in MANUAL or REMOTE operation)
Press this switch in the rated speed setting mode to fix the rated speed to the rpm displayed in "SET : ***00rpm" (here, ***00rpm indicates the rated speed to be set).
For details, see Section 9.2, "Setting the Rated Speed."

- (2) "STOP" Switch (momentary push button switch, red)
 - STP pump stop operation function (valid in MANUAL operation)
Press this switch to decelerate and stop the STP pump.
The "NORMAL" or "ACCEL." lamp goes out and the "BRAKE" lamp lights simultaneously.
When the number of rotations is less than approx. 2000 rpm while the STP pump is accelerating, the "BRAKE" lamp does not light.

- (3) "RESET" Switch (momentary push button switch, white)
 - Alarm reset function (valid in MANUAL operation only)
When a safety function operates with the "FAILURE" lamp lit, stop the STP pump and remove the cause of the failure. Then, press this switch to restart the STP pump. The "FAILURE" lamp goes out simultaneously.
 - Tuning function (valid in MANUAL or REMOTE operation)
To perform tuning, press and hold this switch for 3 seconds or more when the STP pump is in the levitation state. (See Section 9.1, "Tuning.")

- (4) "MANUAL/REMOTE" Changeover Switch (slide switch, gray)
 - Operation mode selection function
When this switch is set to the position opposite to "ON", the start and stop operations using switches on the front panel are possible (valid in MANUAL operation). In this mode, the REMOTE lamp is off.
When this switch is set to "ON", the start and stop operations using remote signals are possible (valid in REMOTE operation). In this mode, the REMOTE lamp is on.

- (5) "SELECT" Switch (momentary push button switch, white)
 - LCD message change function (valid in MANUAL or REMOTE operation)
Press this switch to change the message on the LCD.
 - Error record display function (valid in MANUAL or REMOTE operation)
When this switch is kept pressed for 3 seconds or more when the LCD displays a

STP-301/451 Series Instruction Manual

pump's operation state ("LEVITATION", "ACCEL." and other.) or the pump's temperature, the LCD displays the operating hours (cumulative) or an error message which occurred in the past. (See Section 11, "Troubleshooting, Maintenance and Inspection.")

(6) LCD

- The LCD displays a pump's operation state, speed, or other messages.
- The LCD displays an error message when an abnormality occurs in the STP pump.

(7) "ACCEL." Lamp (green LED)

- Lights during acceleration (ACCELERATION state).

(8) "NORMAL" Lamp (green LED)

- Lights during rated speed operation (NORMAL OPERATION state).

(9) "BRAKE" Lamp (yellow LED)

- Lights during deceleration (BRAKE state).

(10) "POWER" Lamp (green LED)

- Lights while the power is ON.
- Goes out while the backup power is being supplied.

(11) "FAILURE" Lamp (red LED)

- Lights when any of the following abnormalities occurs.
- The LCD displays an error message simultaneously.
 - a) When the inside of the STP control unit overheats (70°C or more inside the circuit);
 - b) When the inside of the STP pump overheats (110°C or more inside the motor or electromagnet);
 - c) When the motor driver overloads;
 - d) When a power failure occurs;
 - e) When the STP connection cable is not connected;
 - f) When vibration impact is continuously applied to the rotor causing it to come into contact with the touch down bearing.

(12) "REMOTE" Lamp (green LED)

- This lamp is on while the operation mode is remote.

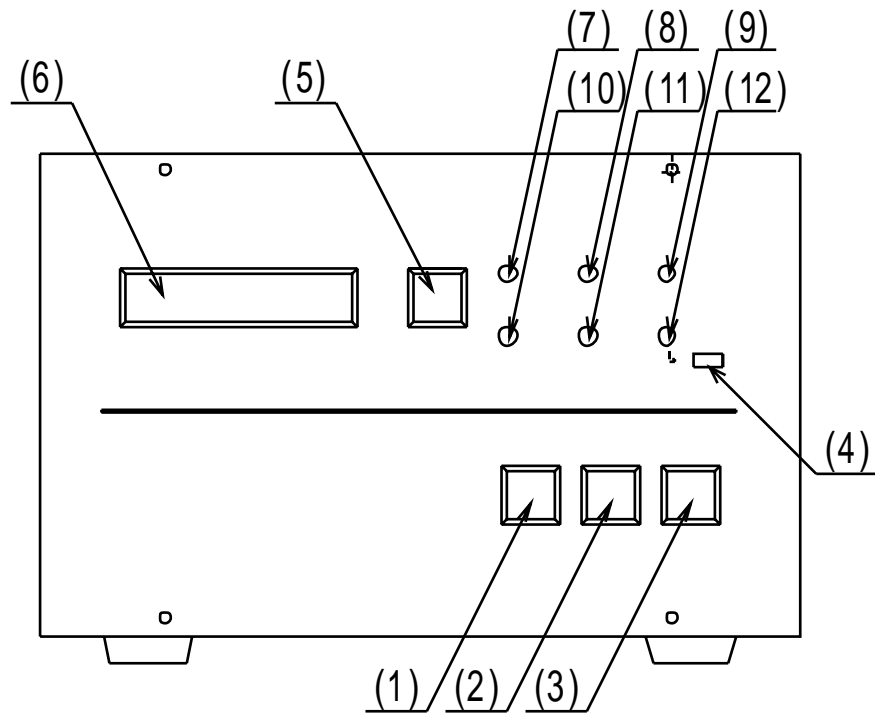



Figure 6.1 STP Control Unit Front Panel



A hazardous live voltage may exist at connector/terminal that marked . DO NOT touch the terminal. Doing so may result in electric shock. When operating connection/disconnection to connector, always power OFF the STP pump (Switch the breaker "OFF").

(13) AC POWER Connector (CON1)

A maximum voltage: Equal to the input voltage of this connector. (MAX 240VAC)

- For primary power input.

(14) MAIN POWER Breaker

- Switches ON/OFF the primary power.
- A metal fitting is attached to secure the breaker at the OFF position.

(15) P. CONNECTOR (CON2)

A maximum voltage: 62VAC

- For connection of the STP connection cable.

(16) Ground Terminal

- For connection of the ground cable between the STP pump and the STP control unit.

(17) I/O TB1 Terminal Block

A maximum voltage: Equal to the input voltage of this connector. (MAX 240VAC)

- For remote output signals.

(18) I/O TB2 Terminal Block

A maximum voltage: Equal to the input voltage of this connector. (MAX 240VAC)

- For remote input signals.

(19) F1 Fuse(250 V,10 A)

(20) F2 Fuse(250 V,10 A)

- For protection of optional power supply for the I/O TB1 terminal block.

(21) CON 4 Connector (Optional accessory)

A maximum voltage: Equal to the input voltage of this connector. (MAX 125VAC)

- For remote input/output signals.
This connector can maintain compatibility with the remote I/O signal of the STP-200/300/400 series.

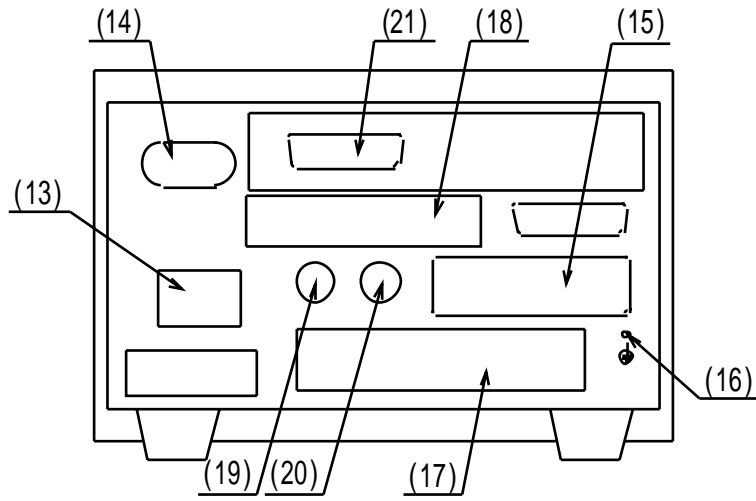

Figure 6.2 STP Control Unit Rear Panel

STP-301/451 Series Instruction Manual

6.1.3 Top Panel

(22) VR1 Volume

- For setting the rated speed of the STP pump.
This volume is normally made ineffective. (See Section 9.2, "Setting the Rated Speed.")

(23) DSW-B Dip Switches

- For optional settings.
Figure 6.3 shows the functions and the factory settings of the dip switches.

<No.1 switch (Rated speed setting)>

Rated speed can be changed by switching this switch "ON." (see Section 9.2, "Setting the Rated Speed")

<No.4 switch (Remote input signal change) >

It is valid with only the specification of remote connector CON4 (special accessory).

The state of input terminal and connector can be changed by this switch "ON/OFF" operation.

No.4 switch	Remote input signal	
	Remote connector CON4	Remote terminal block TB2
ON	Valid	Invalid
FF	Invalid	Valid

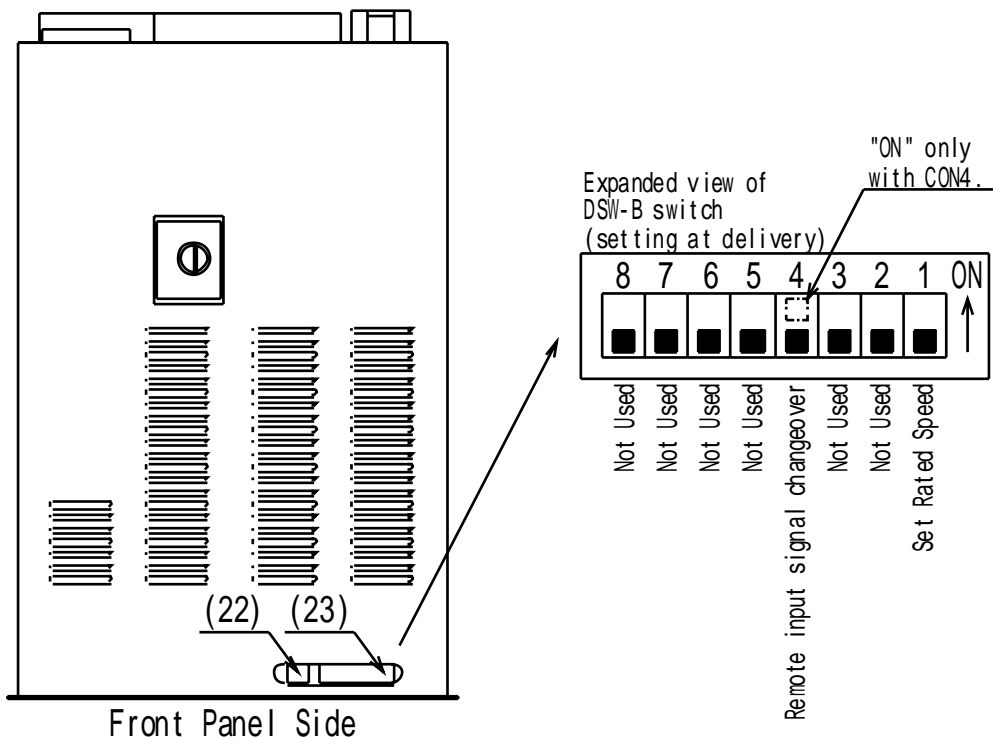

Figure 6.3 STP Control Unit Top Panel

6.1.4 Side Panel (Left)

(24) Air Cooling Fan

- For cooling the inside of the STP control unit.

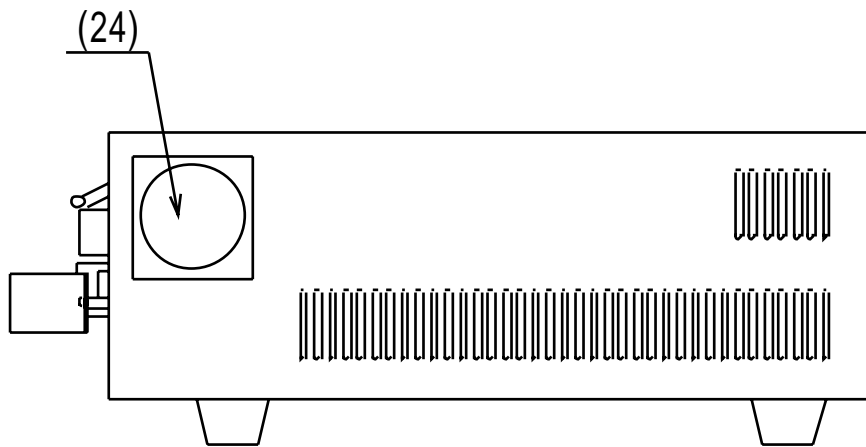

Figure 6.4 STP Control Unit Side Panel (Left)

STP-301/451 Series Instruction Manual

6.2 Precautions Before Installation

6.2.1 Operating Environment

Install the STP control unit in a place meeting the following requirements:

Ambient Temperature	0 to 40 °C
Ambient Relative Humidity	30 to 95% (no dew condensing)
Environment	<ul style="list-style-type: none"> ● A place free of exposure to direct sunlight. ● A place free of high humidity. ● A place free of dust. ● A place free of salty air. ● A place free of dripping water. ● A place free of explosive or inflammable gas. ● A place free of corrosive gas. ● A place free of radiation. ● A place free of strong magnetic and electric fields. ● A place free of excessive vibration. ● A place free of a source of electric noise.
Installation Condition	<ul style="list-style-type: none"> ● Install the STP control unit horizontally (within $\pm 10^\circ$).

6.2.2 Insulation Test

Do not perform the insulation test (insulation resistance test and withstand voltage test) to the STP control unit.

When performing the insulation test to your equipment, turn "OFF" the STP control unit so that the test voltage is not applied to the STP control unit.



The varistor for the power supply line protection is installed to the STP control unit.

DO NOT perform the insulation test with the varistor installed. Doing so may result in product damage.

6.2.3 Installation Area

Leave enough spaces for the following in addition to the space for the STP control unit.

- Space for maintenance and inspection
 - Top and side: 5cm or more
 - Bottom: 1.8cm or more (height of the rubber foot)
- Space for connecting the cables
 - Rear: 15cm or more



The minimum bending radius of the STP connection cable is 150 mm (see Figure 13.5, "External Appearance of the STP Control Unit" [Cable Space]). DO NOT excessively bend the cables and be aware of any obstacles when installing the STP pump. Also, leave enough space to install other cables without bending them excessively.

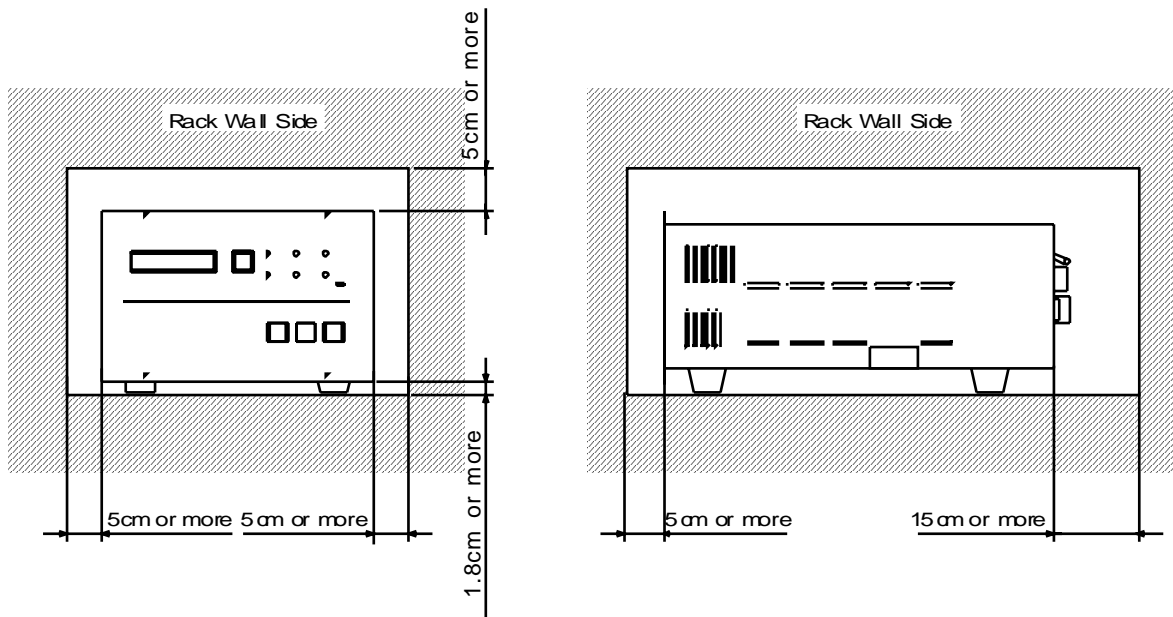

Figure 6.5 Peripheral Spaces of the STP Control Unit

STP-301/451 Series Instruction Manual

6.3 Attaching the STP Control Unit Front Panel to a Rack

The dimensions of the STP control unit front panel conform to EIA Standard. Therefore, this panel can be attached to any type of commercially-available racks. Attach the front panel unit to the rack according to the following steps:

- Attach the front panel to a rack using the screw holes for the front panel.
- Also support the STP control unit from the bottom using a support angle or a similar tool.
- To protect the STP control unit during transport, remove the rubber foot from the bottom and attach the STP control unit to the rack using the screw holes for the rubber foot.



The STP control unit cannot be supported with only the screws on the front panel (the STP control unit is a heavy product).

Always support it from the bottom.

When installing the STP control unit, DO NOT block the ventilation port of the STP control unit by the support angle or other things. It causes the control unit to overheat.



For the dimensions of the front panel and positions of screw holes for the rubber foot, see Figure 13.5, "External Appearance of the STP Control Unit."

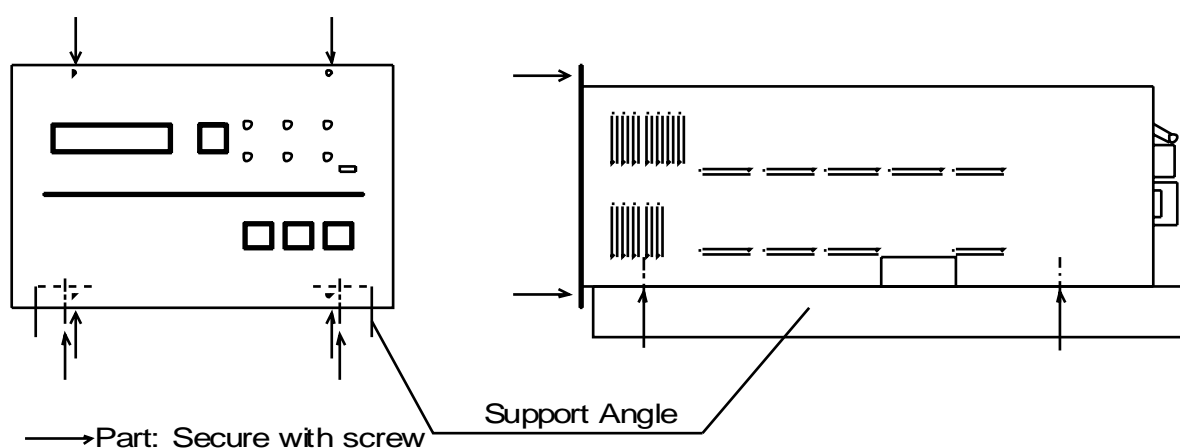

Figure 6.6 Example of Securing the STP Control Unit

6.4 Cable Connection

6.4.1 Name and Dimensions of Each Cable

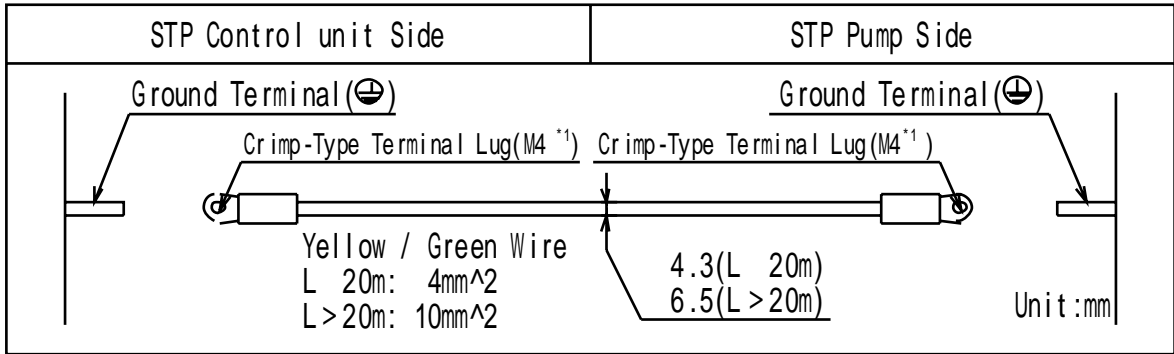

Figure 6.7 External Dimensions of Ground Cable

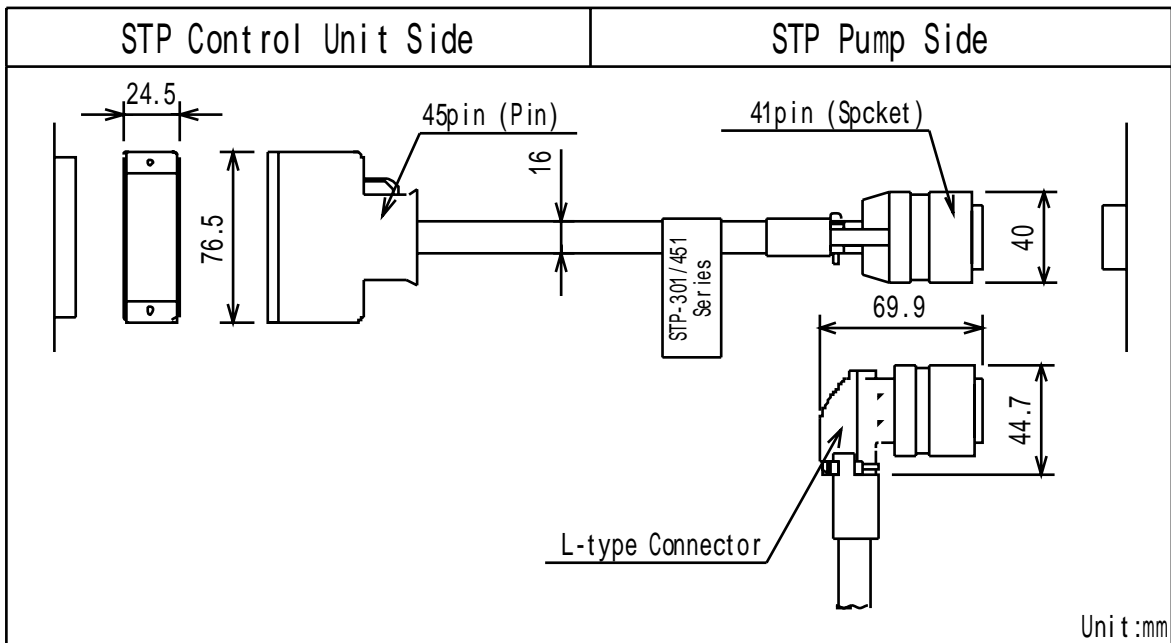
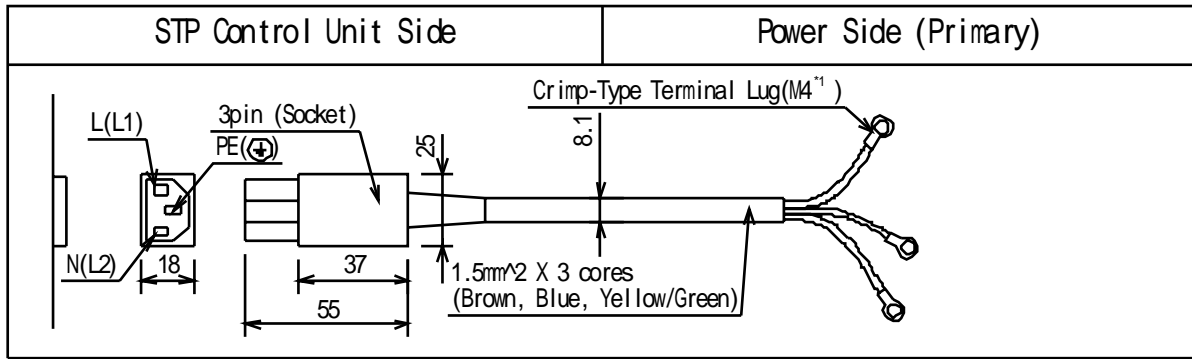
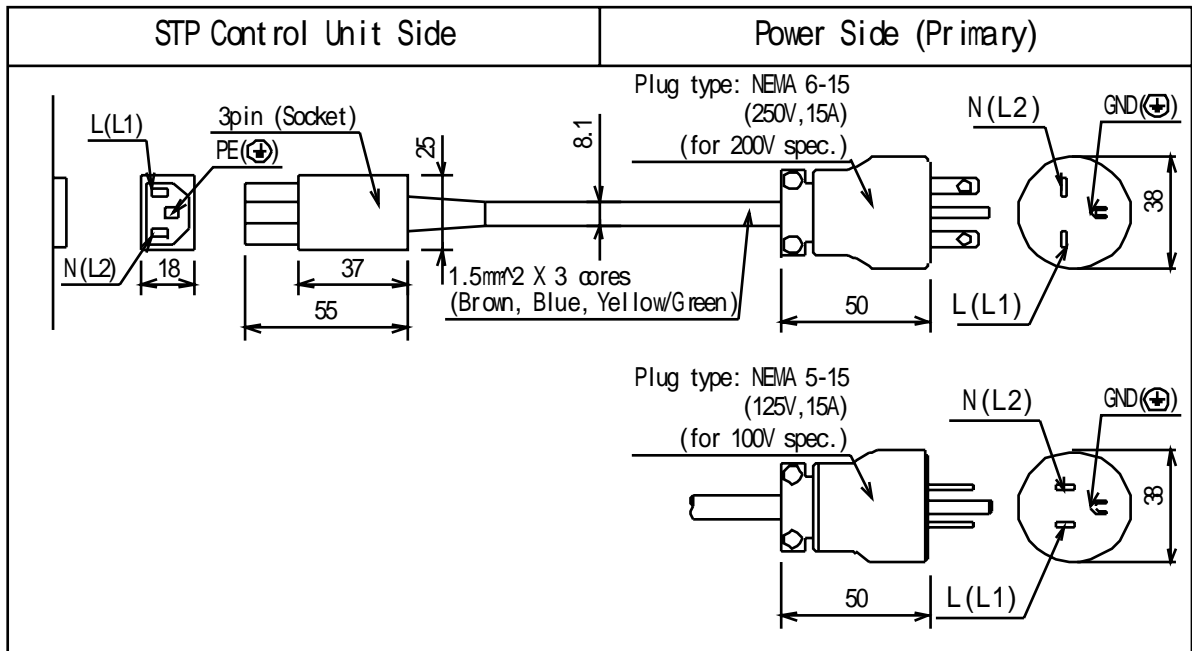

Figure 6.8 External Dimensions of STP Connection Cable

*1: JIS



a) without power plug



b) with power plug^{*2}

Figure 6.9 External Dimensions of STP Connection Cable

*1 : JIS

*2 : Recognized model to UL3101-1 standard has power cable with the plug.

6.4.2 How to Connect the Cables



When connecting/disconnecting cables, always power OFF the STP pump (switch the breaker "OFF").

Failure to do so may result in electric shock or product damage.

With each connector, align the position of the guide key and insert the pin vertically so as not to bend it.

If the pin is bent, not only may the connector not function normally, but may make the pins contact each other, resulting in a malfunction.

Lock and securely tighten each connector and screw.

DO NOT apply a voltage to each pin and DO NOT cause any short-circuiting between pins.

Connect each cable securely. DO NOT place heavy objects on the cables nor bend them excessively.

Support each cable so as not to apply direct force to the connectors or terminals.

If any problem occurs in cables, connectors or terminals, the STP pump may not function normally.

1) Connecting the Ground Cable

Connect the ground cable (yellow/green) between the ground terminal of the STP pump and the ground terminal of the STP control unit.

When the resistance between the ground terminals is lower than 0.1 ohms, it is not necessary to connect the ground cable after installing the STP pump and the STP control unit.



First, connect the ground cable. Next, connect other cables.

When the resistance between the ground terminals is over 0.1 ohms, always connect the ground cable. Failure to do so may result in electric shock.

2) Connecting the STP Connection Cable

Connect the receptacle side of the STP connection cable to the STP connector of the STP pump and connect the plug side to "P.CONNECTOR CON2" of the STP control unit.



Always use the STP pump and STP control unit of the same model name and serial number.

If you plan to use units having the same model name but different serial numbers or to change the length of the STP connection cable, the tuning is required. To perform the tuning, see Section 9.1, "Tuning." If the units are used without tuning, they may not operate normally.

STP-301/451 Series Instruction Manual

If you plan to use the units having different model names, they may not be used even when the tuning is performed. In the latter case, contact service office. Use the STP connection cable that has a label affixed

The use of different cables may result in product damage.

3) Connecting the Power (Primary Side) Cable

Connect the power cable to the "AC POWER CON1" on the STP control unit rear panel as shown in Table 6.1.

Secure the power cable connector using the cable fitting tool (see Figure 6.10).

Table 6.1 Connecting the Power Cable

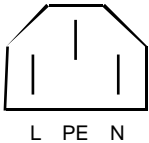
CON1 Pin No.	Cable Color	Remarks	Rear Panel "AC POWER CON1" Outline of connector
L (L1)	Brown	Single phase 200 to 240 V AC +/-10% (for 200 V specification)	
N (L2)	Blue	Single phase 100 to 120 V AC +/-10% (for 100 V specification)	
		Both 50/60 Hz	
PE	Yellow/Green	Ground	



Confirm the power voltage on the name plate.
 Connect the primary power cable securely to prevent incorrect wiring.
 DO NOT apply surge voltage exceeding 1kV to the input power line.
 Always ground the primary power cable to prevent electric shock.

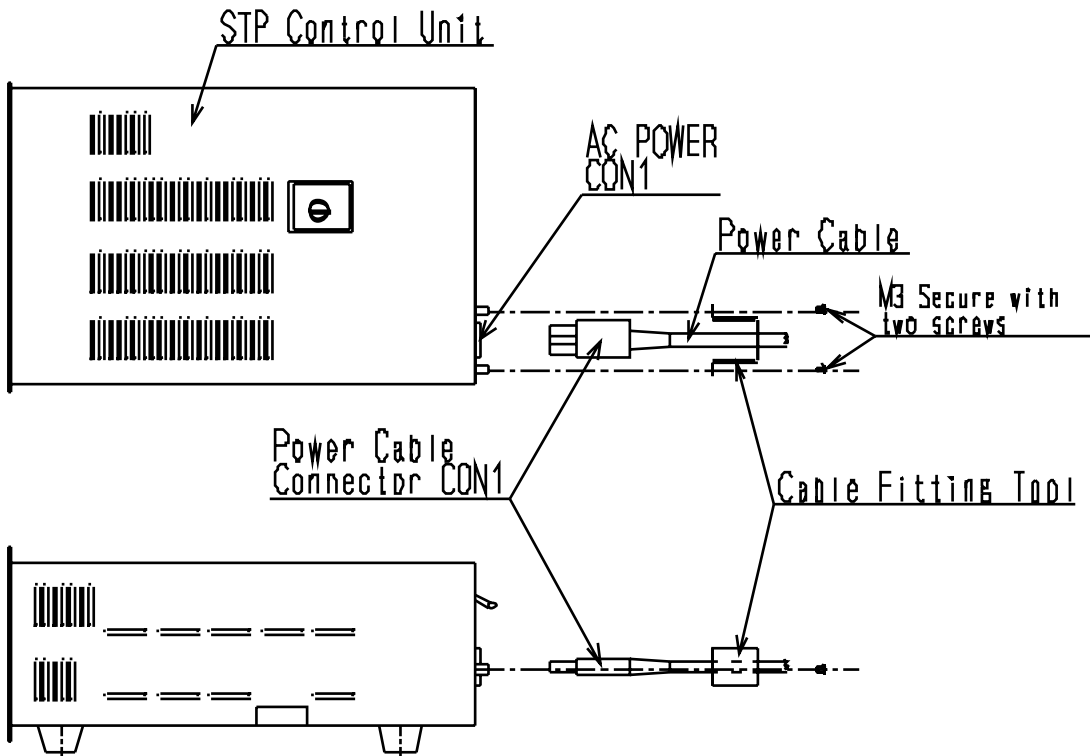

Figure 6.10 How to Secure the Power Cable

The STP pump is a component system when installing to the semiconductor equipment. Consider the followings when designing the semiconductor equipment.

6.4.3 Connecting to Power

The STP control unit receives its power from the semiconductor equipment electrical distribution system via a circuit breaker.

Electrical energy isolation (Lockout/Tagout) is achieved by opening the main disconnect device or circuit breaker of the semiconductor equipment, thereby: removing power from the STP pump.

Provide the equipment with the main disconnect or circuit breaker devices rated for at least 10,000 A_{rms} symmetrical amperes interrupting capacity (AIC).

6.4.4 Emergency Off Circuit (EMO Circuit)

Activation of EMO circuit of the equipment will interrupt electrical power from the STP control unit.

When the power is shut off, the STP pump performs the same as a power failure. (After backup operation of a power failure, the rotor lands on the touch down bearing)

Consider the followings when establishing the EMO circuit.



Unite the exhaust gas system to prevent atmosphere from being introduced into the STP pump when the EMO circuit operates. (example: shut the valve) When atmosphere is introduced into the STP pump, the touch down bearing may not operate normally.

The STP pump rotates for a while after the EMO circuit shuts off the power.

Perform a recovery operation after the STP pump has stopped completely.

Before performing the operation check of the EMO circuit with regular

maintenance, stop the STP pump to prevent damage to the touch down bearing.

7 How to Start/Stop the STP Pump



NEVER connect or disconnect any cables while the power is ON.
NEVER turn the primary power OFF (switch the breaker "OFF") while the STP pump is in rotation.
DO NOT release the inlet port flange or outlet port flange into the atmosphere while the STP pump is in rotation.

7.1 Before Starting

After completing the installation, piping, leakage test of the STP pump, installation of the STP control unit, and wiring, the STP pump is ready for start.

Check the following items before starting:

- 1) Are the STP pump and the STP control unit secured according to the appropriate method?
- 2) Is the primary power cable connected correctly to the power supply?
- 3) Is the power voltage selected properly?
- 4) Are the ground cable and STP connection cable securely connected?
Are each terminal and each connector securely locked?
- 5) Is the label affixed correctly to the STP connection cable?

STP-301/451
Series

- 6) Is the serial number of the STP pump the same as that of the STP control unit?
If they are different, perform the tuning according to Section 9.1, "Tuning."
- 7) Did you change the STP connection cable length? If you did, perform the tuning according to Section 9.1, "Tuning."

7.2 Start Procedures

Start the backing pump before or simultaneously with the start of the STP pump. Open the vacuum valve located at the outlet port flange side after starting the backing pump.



DO NOT open the vacuum valve without operating the backing pump. Depending upon the type of the backing pump, doing so may cause a reverse flow of oil, which could contaminate the inside of the STP pump. When start/stop operations are frequently performed, the STP pump may overheat. Avoid doing so.

7.3 Stop Procedures

Close the vacuum valve located at the outlet port flange side just before or after stopping the STP pump. After closing the valve, stop the backing pump.



DO NOT stop the backing pump without closing the vacuum valve. Depending upon the type of the backing pump, doing so could cause a reverse flow of atmospheric air into the STP pump, which may result in a malfunction.



DO NOT stop the backing pump without closing the valve. Depending upon the type of the backing pump, doing so may cause a reverse flow of oil, which could contaminate the inside of the STP pump.

There are two methods of operating the STP pump: MANUAL and REMOTE.

Select one which fits your vacuum equipment.

7.4 Manual Operation

Slide the "MANUAL/REMOTE" changeover switch on the STP control unit front panel to the position opposite to "ON." At this time, the "REMOTE" lamp is off.

7.4.1 Powering ON

- 1) Switch "ON" the breaker on the rear panel.
(To prevent incorrect operation, a metal fitting is attached to the breaker. Loosen the screw, lift the metal fitting, and secure it.)
The magnet bearing functions and the rotor levitates (POWER ON state).
The "POWER" lamp lights.
- 2) The STP control unit executes the self test. If no error is found, the LCD displays "LEVITATION."

7.4.2 Starting the STP Pump

- 1) Press the "START" switch on the front panel to start and accelerate the STP pump. The "ACCEL." lamp lights. The LCD displays the current rotational speed in "ACCEL: ***00rpm" in units of 500 rpm (ACCELERATION state).
- 2) When the STP pump attains the rated speed of rotations, the "ACCEL." lamp goes out, and the "NORMAL" lamp lights. Also, the LCD displays "NORMAL: ***00rpm" (NORMAL OPERATION state).



The STP pump can be manually started only when the LCD displays "LEVITATION" or "BRAKE: ***00rpm".

In the case of another message displayed, press the "SELECT" switch one or more times until "LEVITATION" or "BRAKE: ***00rpm" is displayed.

Although the STP pump sounds for several seconds while it is accelerating, this is not an indication of abnormality.

7.4.3 Stopping the STP Pump

- 1) Press the "STOP" switch on the front panel to stop the STP pump. The "NORMAL" lamp or "ACCEL." lamp goes out, and the "BRAKE" lamp lights (BRAKE state).
(The "BRAKE" lamp does not light when the number of rotations is less than 500 rpm.)
- 2) The "BRAKE" lamp goes out when the number of rotations goes below 500 rpm.



The STP pump can be stopped with any message displayed in the LCD.

7.4.4 Starting the STP Pump after Stopping

Press the "START" switch on the front panel to reaccelerate the STP pump. The STP pump can be reaccelerated even while it is stopping.



The STP pump can be reaccelerated only when the LCD displays "LEVITATION" or "BRAKE: ***00rpm."

7.4.5 Powering OFF

Switch "OFF" the breaker on the rear panel when all three lamps of "ACCEL.", "NORMAL", and "BRAKE" are off.

The magnetic bearing stops, the rotor lands, and the "POWER" lamp goes out (POWER OFF state).



NEVER switch OFF the breaker when any lamp of "ACCEL.", "NORMAL", and "BRAKE" is on. Doing so causes such a state as a power failure.

7.4.6 Starting the STP Pump after a Safety Function Operates

A safety function operates when an abnormality occurs in the STP pump or peripheral equipment. To restart the STP pump, remove the cause of the abnormality after the "BRAKE" lamp goes out, and press the "RESET" switch.

The "FAILURE" lamp goes out and the safety function is released (RESET operation). Then, press the "START" switch.

For the safety functions and troubleshooting, see Section 10, "Safety Functions " and Section 11, "Troubleshooting, Maintenance and Inspection."

7.5 Remote Operation (I/O TB2)

(Read through Section 8.2, "I/O TB 2 Terminal Block" before use.)

Slide the "MANUAL/REMOTE" changeover switch on the STP control unit front panel to "ON." The "REMOTE" lamp lights.

7.5.1 Powering ON

- 1) Switch "ON" the breaker on the STP control unit rear panel.
(To prevent incorrect operation, a metal fitting is attached to the breaker. Loosen the screw, lift the metal fitting, then secure it.)
The magnetic bearing functions and the rotor levitates (POWER ON state).
The "POWER" lamp lights.
- 2) The STP control unit executes the self test. If no error is found, the LCD displays "LEVITATION."

7.5.2 Starting/Stopping the STP Pump

There are three methods of starting/stopping the STP pump. Use one of them.

Table 7.1 Starting/Stopping the STP Pump during Remote Operation (I/O TB2)

Method	Starting the Pump	Stopping the Pump
1	<ol style="list-style-type: none"> 1) With the circuit between <u>(2)-(3)</u> shorted, short the circuit between <u>(1)-(4)</u>. 2) Short the circuit between <u>(4)-(5)</u> for 0.3 seconds or more. However, when inputting the signal simultaneously with switching "ON" the breaker on the rear panel, continue to short the circuit for 5 seconds or more. 	Open the circuit between <u>(1)-(4)</u> .
2	With the circuit between <u>(2)-(3)</u> shorted, short the circuit between <u>(1)-(5)</u> .	Open the circuit between <u>(1)-(5)</u> .
3	Input 25 V AC or 12 to 48 V DC between <u>(3)-(5)</u> . With DC, the (+) side can be connected to either <u>(3)</u> or <u>(5)</u> .	Open the circuit between <u>(3)-(5)</u> .



When using method 3 shown in the above table, 25 to 250 V AC can be input. In this case, attach a metallic cover or a similar part to the terminal block to ensure the safety.



The STP pump can be started by remote operation with any message displayed on the LCD.
Although the STP pump sounds for several seconds while it is accelerating, this is not an indication of abnormality.

7.5.3 Starting the STP Pump After Stopping

Perform the rotation procedures to reaccelerate the STP pump. See Section 7.5.2, "Starting/Stopping the STP Pump."

The STP pump can be reaccelerated even while it is stopping.



The STP pump can be reaccelerated by remote operation with any message displayed on the LCD.

7.5.4 Powering OFF

Switch "OFF" the breaker on the rear panel when all three lamps of "ACCEL.", "NORMAL," and "BRAKE" are off.

The magnetic bearing stops, the rotor lands, and the "POWER" lamp goes out (POWER OFF state).



NEVER switch OFF the breaker when any lamp of "ACCEL.", "NORMAL," and "BRAKE" is on. Doing so causes such a state as a power failure.

7.5.5 Starting the STP Pump after a Safety Function Operates

A safety function operates when an abnormality occurs in the STP pump or peripheral equipment. To restart the STP pump, remove the cause of the abnormality after the "BRAKE" lamp goes out, and perform either operation shown in Table 7.2. The "FAILURE" lamp goes out and the safety function is released (RESET operation). Then, start the STP pump.

For the safety functions and troubleshooting, see Section 10, "Safety Functions " and Section 11, "Troubleshooting, Maintenance and Inspection."

Table 7.2 Reset Operation during Remote Operation (I/O TB2)

Method	Reset Operation
1	With the circuit between <u>(2)-(3)</u> shorted, short the circuit between <u>(6)-(1)</u> (terminals for reset signal) for 0.3 seconds or more.
2	Input 25 V AC or 12 to 48 V DC between <u>(6)-(3)</u> (terminals for reset signal) for 0.3 seconds or more. With DC, the (+) side can be connected to either <u>(3)</u> or <u>(6)</u> .



When using method 2 shown in the above table, 25 to 250 V AC can be input. In this case, attach a metallic cover or a similar part to the terminal block to

ensure the safety.

7.6 Remote Operation (CON4: Optional Accessory)

(Read through Section 8.3, "CON4 connector" before use.)

The CON4 connector (special accessory) is available in the STP-301/451 series in order to maintain compatibility with the remote specification of the previous model of the STP-200/300/400 series.

This connector can maintain compatibility with the remote I/O signal of the STP-200/300/400 series.

When using the CON4 connector, follow the procedure below:

- 1) Switch "ON" the No.4 switch of the DSW-B on the top panel.
(Refer to Figure 6.3, "STP Control Unit Top Panel" for the position of "DSW-B.")
In this case, remote input from I/O TB2 terminal is invalid.
- 2) Slide the "MANUAL/REMOTE" changeover switch on the STP control unit front panel to "ON." The "REMOTE" lamp lights.

7.6.1 Powering ON

- 1) Switch "ON" the breaker on the STP control unit rear panel.
(To prevent incorrect operation, a metal fitting is attached to the breaker. Loosen the screw, lift the metal fitting, then secure it.)
The magnetic bearing functions and the rotor levitates (POWER ON state).
The "POWER" lamp lights.
- 2) The STP control unit executes the self test. If no error is found, the LCD displays "LEVITATION."

7.6.2 Starting/Stopping the STP Pump

Table 7.3 Starting/Stopping the STP Pump during Remote Operation (CON4)

Starting the Pump	Stopping the Pump
Input 24 V DC between (3) (15) (pin for start signal) for 0.3 seconds or more. Connect the (+) side to (3), and the (-) side to (15). However, when inputting the signal simultaneously with switching "ON" the breaker on the rear panel, continue to short the circuit for 5 seconds or more.	Input 24 V DC between (4) (16) (pin for stop signal) for 0.3 seconds or more. Connect the (+) side to (4), and the (-) side to (16). This STOP signal has priority over the START signal.



The STP pump can be started by remote operation with any message displayed on the LCD.

Although the STP pump sounds for several seconds while it is accelerating, this

is not an indication of abnormality.

7.6.3 Starting the STP Pump After Stopping

Perform the rotation procedures to reaccelerate the STP pump. See Section 7.6.2 "Starting/Stopping the STP Pump."

The STP pump can be reaccelerated even while it is stopping.



The STP pump can be reaccelerated by remote operation with any message displayed on the LCD.

7.6.4 Powering OFF

Switch "OFF" the breaker on the rear panel when all three lamps of "ACCEL.", "NORMAL", and "BRAKE" are off.

The magnetic bearing stops, the rotor lands, and the "POWER" lamp goes out (POWER OFF state).



NEVER switch OFF the breaker when any lamp of "ACCEL.", "NORMAL," and "BRAKE" is on. Doing so causes such a state as a power failure.

7.6.5 Starting the STP Pump after a Safety Function Operates

A safety function operates when an abnormality occurs in the STP pump or peripheral equipment. To restart the STP pump, remove the cause of the abnormality after the "BRAKE" lamp goes out, and perform either operation shown in Table 7.4 The "FAILURE" lamp goes out and the safety function is released (RESET operation).

Then, start the STP pump.

For the safety functions and troubleshooting, see Section 10, "Safety Functions " and Section 11, "Troubleshooting, Maintenance and Inspection."

Table 7.4 Reset Operation during Remote Operation (CON4)

Reset Operation
Input 24 V DC between (2) (14) (pin for reset signal) for 0.3 seconds or more.
Connect the (+) side to (2), and the (-) side to (14).

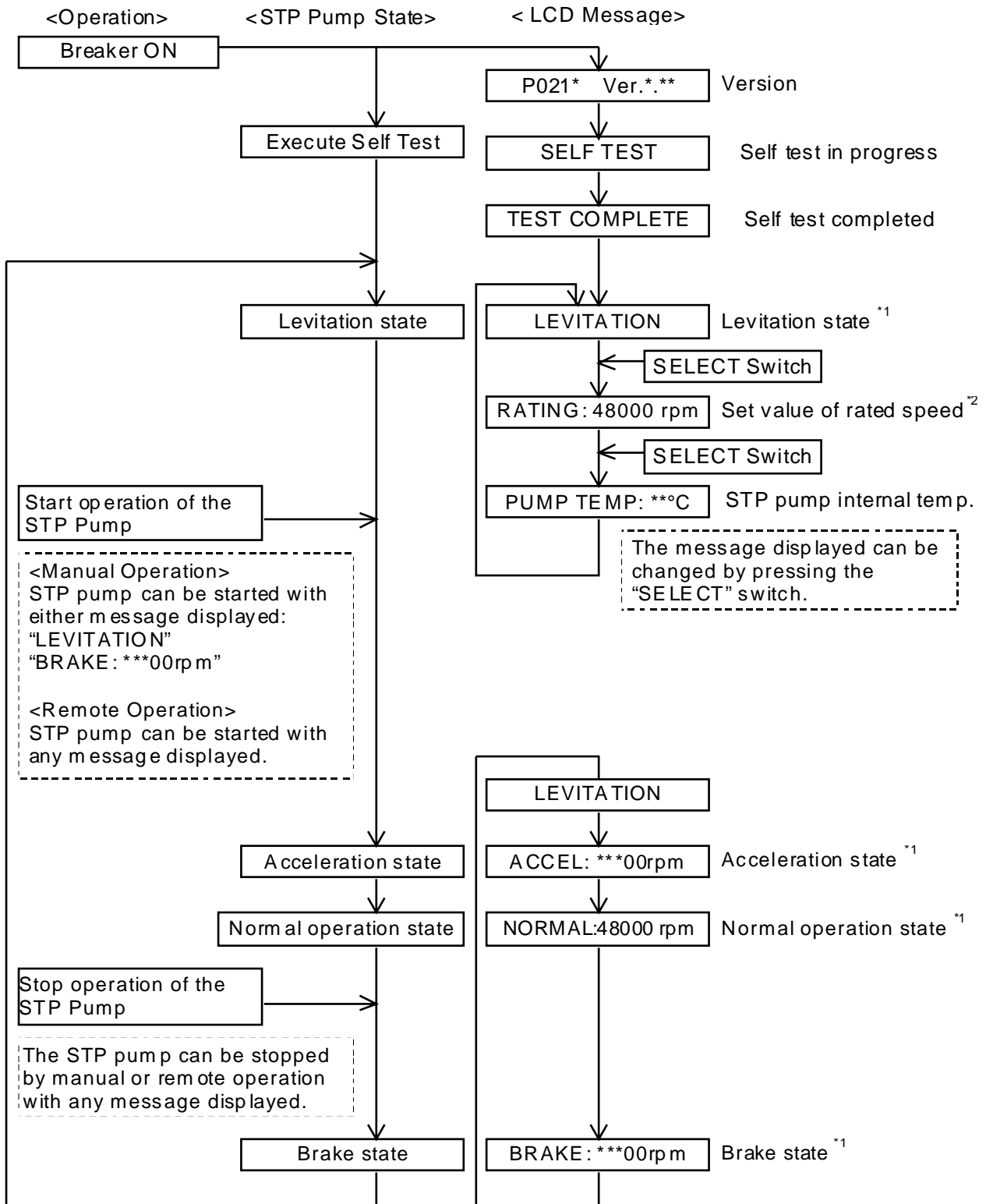

Figure 7.1 STP Pump Operation Procedures

^{*1}: When the SELECT switch is pressed with this message displayed, the message changes to "RATING:48000 rpm," and when pressed again, to "PUMP TEMP:**°C."

^{*2} For the setting of the rated speed, see Section 9.2,"Setting the Rated Speed."

8 Remote Input/Output Signal Terminal Blocks

8.1 I/O TB1 Terminal Block

This is a terminal block for remote output signals. Use it in accordance with Table 8.1 and Figure 8.1. This terminal block functions in both the MANUAL and REMOTE operations.

The screw for the terminal is M3.5*1.

Five abbreviations are used in the following table:

N.O: Normal Open N.C: Normal Close COM: Common
 IN: Input Terminal OUT: Output Terminal



When connecting the power supply for the air cooling unit to terminals (1)-(4), attach a metallic cover or a similar part to the terminal block to ensure the safety.

Table 8.1 I/O TB1 Terminal Block

Terminal	Description
(1) AC.POWER N1 IN L1 (2)	Terminals for inputting power for driving the air cooling unit. The voltage input to these terminals is output to the specified terminal block through operation of the STP pump.
(3) FAN N.O OUT (4)	Terminals for connecting the air cooling unit. The voltage input to AC. POWER terminals ((1)-(2)) is output to these terminals when the STP pump is in acceleration or rated operation. The voltage is cut OFF when the STP pump is under the BRAKE state (see Section 5.2.2, "Air Cooling Method").
(5) (6)	Not-used. DO NOT use these terminals.
(7) POWER N.O OUT (8)	Terminals for outputting the POWER ON state signal. These terminals are closed when the magnetic bearing functions and the rotor levitates. This signal is cut OFF at a power failure.
(9) (11) N.O N.C ALARM COM OUT (10)	Terminals for outputting the ALARM signal. When an abnormality/error is detected under the POWER ON state, the terminals between (10)-(9) are closed, and the terminals between (10)-(11) are opened. However, when the rotational speed is less than 20,000rpm during power failure backup operation, this signal is not output.

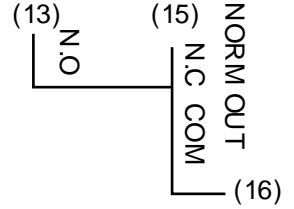
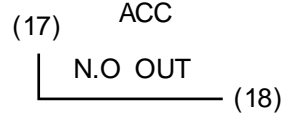
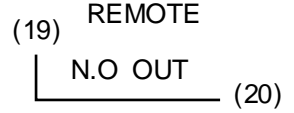
Terminal	Description
	<p>Terminals for outputting the BRAKE state signal. These terminals are closed when the STP pump is in brake. However, when the rotational speed is less than 20,000rpm during power failure backup operation, this signal is not output.</p>
	<p>Terminals for outputting the NORMAL OPERATION state signal. When the STP pump is in rated operation, the terminals between (16)-(13) are closed, and the terminals between (16)-(15) are opened.</p>
	<p>Terminals for outputting the ACCELERATION state signal. These terminals are closed when the STP pump is in acceleration.</p>
	<p>Terminals for outputting the STP pump REMOTE SELECTION state signal. When the MANUAL/REMOTE changeover switch on the STP front panel is set to ON (remote side), these terminals are closed (REMOTE operation). However, when the rotational speed is less than 20,000rpm during power failure backup operation, this signal is not output.</p>

Operation

	(1)	(3)	(5)	(7)	(9)	(11)	(13)	(15)	(17)	(19)	
	(2)	(4)	(6)	(8)	(10)	(12)	(14)	(16)	(18)	(20)	

TB1 Terminal Arrangement

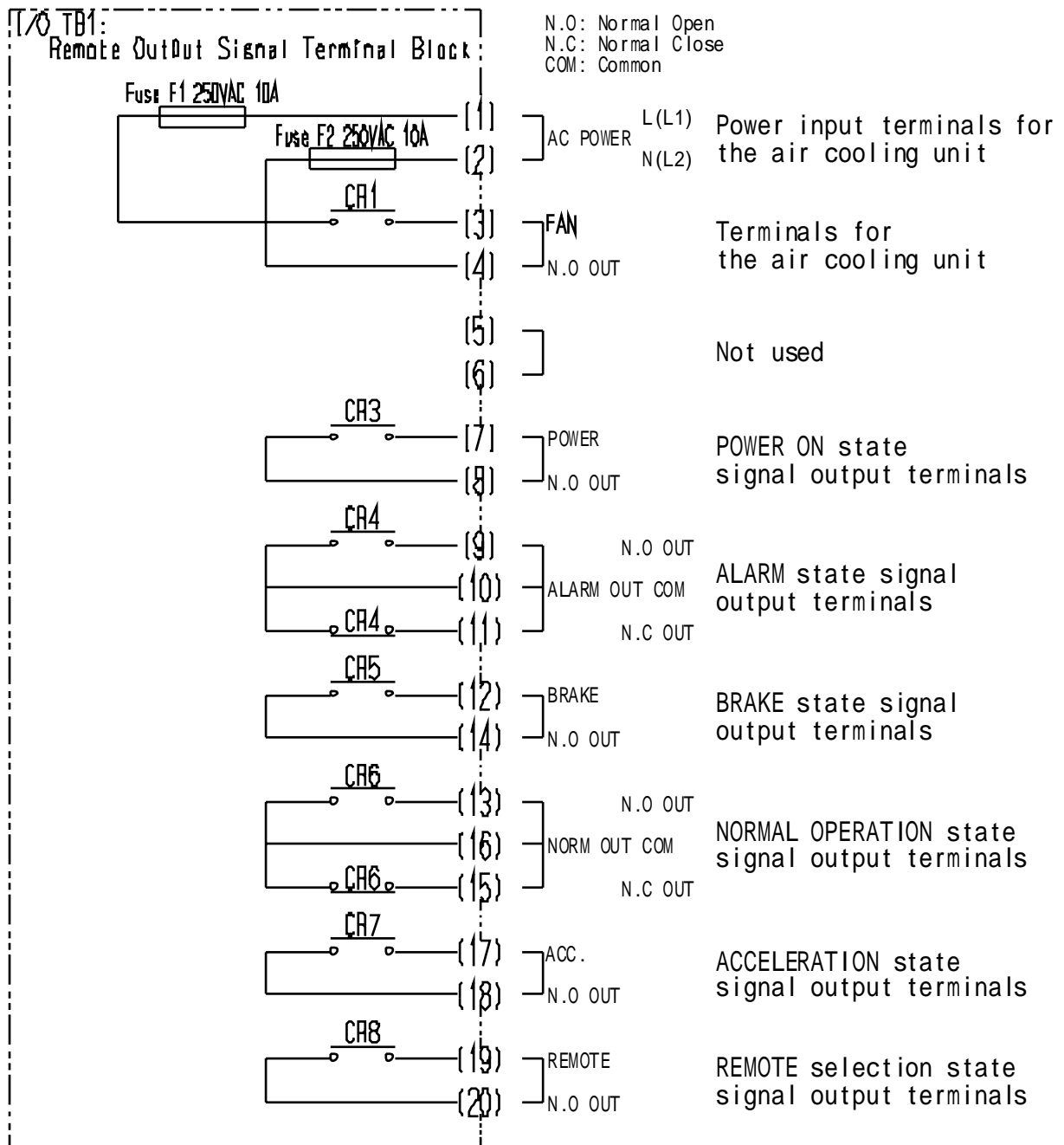

Figure 8.1 I/O TB1 Remote Output Signal Terminal Block

Table 8.2 shows rated contacts for relays CR1, 3, 5, 7, and 8 (see Figure 8.1).

Table 8.2 Rated Contacts for Relays CR1, 3, 5, 7, and 8

	Resistance Load (cos ϕ =1)	Induction Load (cos ϕ =0.4) (L/R=7 ms)
Rated Load	250 V AC 10 A 30 V DC 10 A	250 V AC 5A 30 V DC 5A
Rated Current	10 A	
Maximum Contact Point Voltage	380 V AC 125 V DC	
Maximum Contact Point Current	10 A	
Maximum Open/Close Capacity	AC: 2500 VA DC: 300 W	AC: 1250 VA DC: 220 W
Minimum Applicable Load	5 V DC, 10 mA	

Table 8.3 shows rated contacts for relays CR4 and 6 (see Figure 8.1).

Table 8.3 Rated Contacts for Relays CR4 and 6

	Resistance Load (cos ϕ =1)	Induction Load (cos ϕ =0.4) (L/R=7 ms)
Rated Load	250 V AC 8 A 30 V DC 8 A	250 V AC 6 A 30 V DC 4 A
Rated Current	8 A	
Maximum Contact Point Voltage	380 V AC 125 V DC	
Maximum Contact Point Current	8 A	
Maximum Open/Close Capacity	AC: 2000 VA DC: 240 W	AC: 1500 VA DC: 120 W
Minimum Applicable Load	5 V DC, 100 mA	

8.2 I/O TB2 Terminal Block





This is a terminal block for remote input signals. Use it in accordance with Table 8.4 and Figure 8.2. (See Section 7.5, "Remote Operation (I/O TB2).")

This terminal block operates only during the REMOTE operations. Switch "OFF" the No.4 switch of the DSW-B with CON 4. **The screw for the terminal is M4¹.**

Three abbreviations are used in the following table:

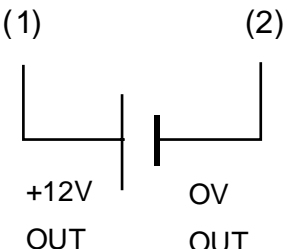
COM: Common IN: Input Terminal OUT: Output Terminal

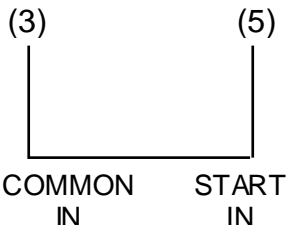
Table 8.4 I/O TB2 Terminal Block

Terminal	Description
	<p>Terminals for outputting the power (12 V DC) for driving remote signals.</p> <div style="display: flex; align-items: center;">  <p>NEVER use these terminals for the purpose except REMOTE operations. DO NOT connect these terminals to another power line. Doing so causes a failure.</p> </div>
	<p>Terminals for inputting the START signal. The following three methods are available:</p> <ol style="list-style-type: none"> 1) Short the circuits between (2)-(3) and (1)-(4). Then, shorting the circuit between (4)-(5) for 0.3 seconds or more causes the STP pump to start. When this signal is input simultaneously with switching ON the breaker on the rear panel, short the circuit for 5 seconds or more. 2) Short the circuit between (2)-(3). Then, shorting the circuit between (1)-(5) causes the STP pump to start. 3) Input 25 V AC or 12 to 48 V DC between (3)-(5) to start the STP pump. With DC input, the (+) side can be connected to either (3) or (5).
	<p>Terminals for inputting the STOP signal. This STOP signal has priority over the START signal.</p> <ol style="list-style-type: none"> 1) When 1) above is used to start the STP pump, open the circuit between (1)-(4) to stop the pump. 2) When 2) above is used, open the circuit between (1)-(5) to stop the pump. 3) When 3) above is used, open the circuit between (3)-(5) to stop the pump.

Operation

¹ JIS

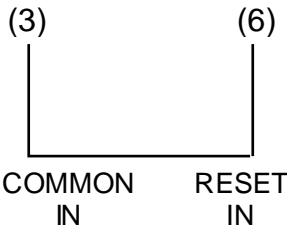
 <p>(3) (6)</p> <p>COMMON IN RESET IN</p>	<p>Terminals for inputting the abnormality RESET signal.</p> <ol style="list-style-type: none"> 1) When 1) or 2) above is used, shorting the circuit between (1)-(6) for 0.3 seconds or more turns off the "FAILURE" lamp. 2) When 3) above is used, input 25 V AC or 12 to 48 V DC between (3)-(6) for 0.3 seconds or more to turn off the "FAILURE" lamp. <p>With DC input, the (+) side can be connected to either (3) or (6).</p>
--	---

CAUTION

When performing all of the START, STOP, and RESET operations using method 3 shown in the above table, 25 to 250 V AC can be input. In this case, attach a metallic cover or a similar part to the terminal block to ensure the safety.

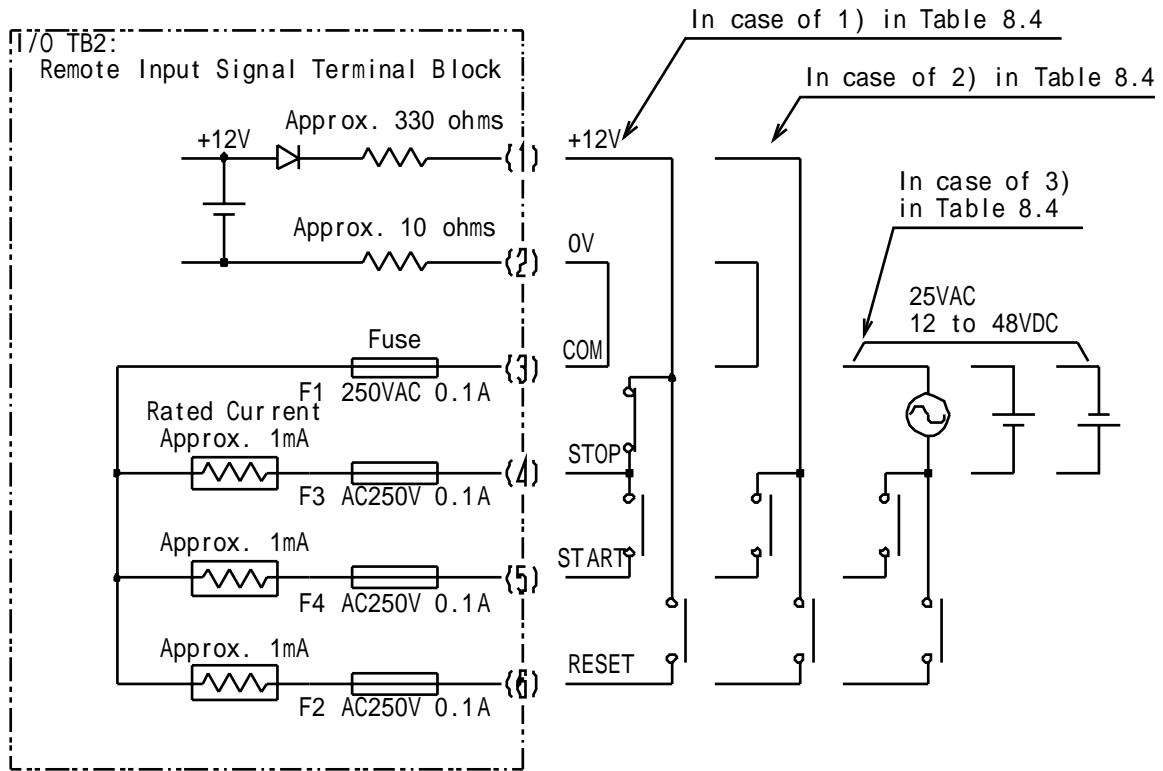

NOTICE

I/O TB2 fuses F1 to 4 are on the substrate in the circuit.
 For their replacement, contact service office.
 The input current of remote input signal is approx. 1mA. Make sure the minimum applicable load of the relay contact when the remote operation with the relay.

Figure 8.2 I/O TB2 Remote Input Signal Terminal Block

8.3 CON4 Connector (Optional accessory)

This is a connector for remote input/output signals.

This connector can maintain compatibility with the remote I/O signal of the STP-200/300/400 series.

The remote input signal from the CON 4 connector is valid by setting No.4 switch of the DSW-B on the top panel to "ON". In this case, remote input from I/O TB2 terminal is invalid.

(Refer to Figure 6.3, " STP Control Unit Top Panel" for the position of "DSW-B.")



This connector is GP-IB*1 type (24pin)

8.3.1 Remote Input Signals

Use input signals according to Table 8.5 and Figure 8.3. See Section 7.6, "Remote Operation (CON4)".

This input signal is valid only when No.4 of the DSW-B is "ON" in the remote operation.

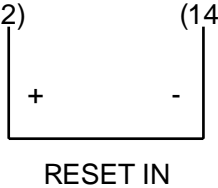
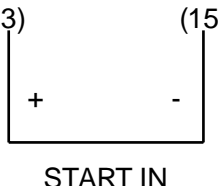
Table 8.5 CON4 Connector (Remote Input Signal)

Pin	Description
 <p>(2) (14) + - RESET IN</p>	<p>Pins for inputting the RESET signal. When inputting 24VDC between (2)-(14) for 0.3 seconds or more, the "FAILURE" lamp is turned off. Connect the (+) side to (2), and the (-) side to (14). (It is an equivalent to the pin for inputting the "POWER OFF" signal of the STP-200/300/400 series.)</p>
 <p>(3) (15) + - START IN</p>	<p>Pins for inputting the START signal. When inputting 24VDC between (3)-(15) for 0.3 seconds or more, the pump starts operation. However, when inputting the signal simultaneously with switching "ON" the breaker on the rear panel, continue to short the circuit for 5 seconds or more. Connect the (+) side to (3), and the (-) side to (15).</p>
 <p>(4) (16) + - STOP IN</p>	<p>Pins for inputting the STOP signal. This STOP signal has priority over the START signal. When inputting 24VDC between (4)-(16) for 0.3 seconds or more, the pump stops operation. Connect the (+) side to (4), and the (-) side to (16).</p>
<p>(1) (13)</p>	<p>Not used. (It corresponds to the pin for inputting the "POWER ON" signal of the STP-200/300/400 series.)</p>

*1: General Purpose - Interface Bus (Conforms to IEEE-STD-488-1978)

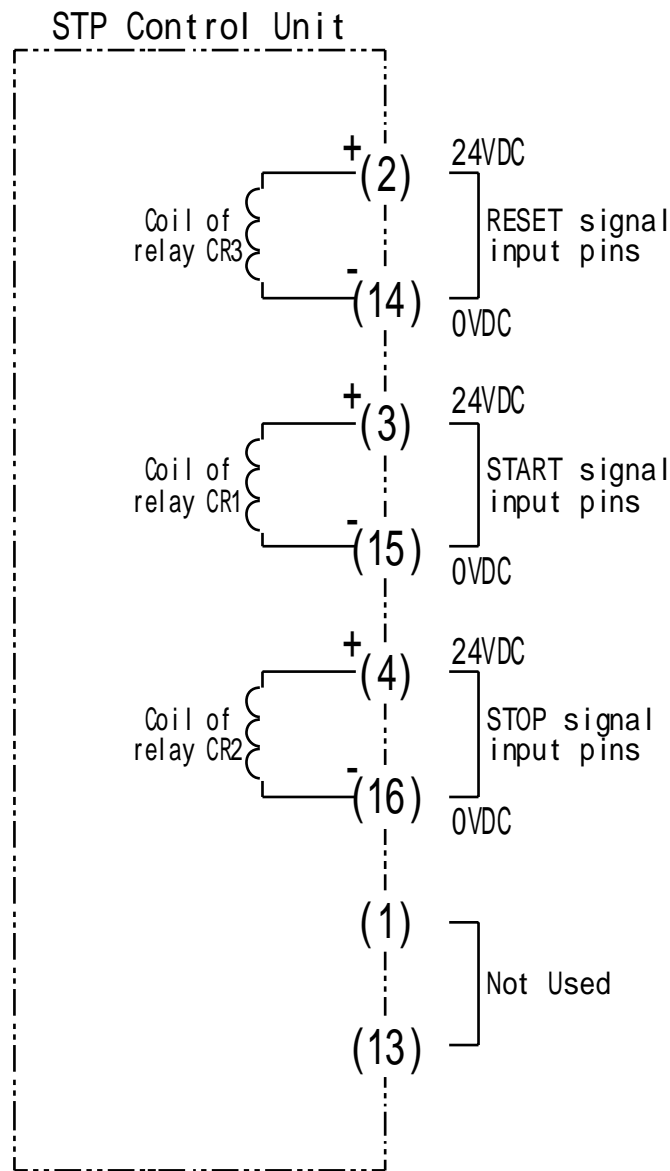

Figure 8.3 CON4 Remote Input Signal Connector

Table 8.6 shows rated coils for relays CR1, 2 and 3. (see Figure 8.3)

Table 8.6 Rated Coils for Relays CR1, 2 and 3

Rated Voltage	Rated Current
DC24V	8.3mA

8.3.2 Remote Output Signals

Use output signals according to Table 8.7 and Figure 8.4.

This output signal operates in both manual operation and remote operation.

No.4 of the DSW-B DIP switch operates in "ON/OFF" both states.

Table 8.7 CON 4 Connector (Remote output signal)

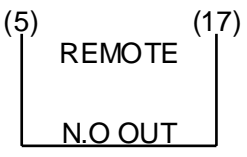
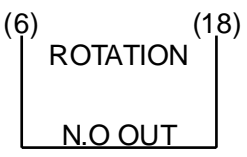
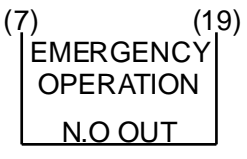
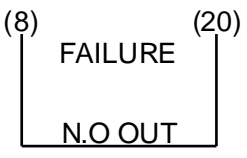
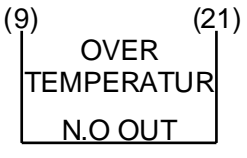
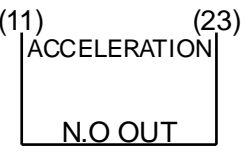
Pin	Description
	<p>Pins for outputting the STP pump REMOTE SELECTION state signal.</p> <p>When the MANUAL/REMOTE changeover switch on the STP front panel is set to ON (remote side), these pins are closed (REMOTE operation).</p> <p>However, during power failure backup operation, this signal is not output.</p>
	<p>Pin for outputting the rotational state signal.</p> <p>These pins are closed when the STP pump is in rotation.</p> <p>However, during power failure backup operation, this signal is not output.</p> <p>(It corresponds to the pin for outputting the "POWER ON" signal of the STP-200/300/400 series.)</p>
	<p>Pins for outputting the EMERGENCY OPERATION state signal.</p> <p>These pins are closed when failures are detected as follows.</p> <ul style="list-style-type: none"> ● Abnormal state of magnetic bearing ● Excessive Vibration <p>However, during power failure backup operation, this signal is not output.</p>
	<p>Pins for outputting the FAILURE state signal.</p> <p>These pins are closed when failures are detected as follows.</p> <ul style="list-style-type: none"> ● Motor driver overload ● Overheating inside the STP pump ● Overheating inside the STP control unit ● Overspeed <p>However, during power failure backup operation, this signal is not output.</p>
	<p>Pins for outputting the OVER TEMPERATURE state signal.</p> <p>These pins are closed when overheating inside the STP pump is detected.</p> <p>However, during power failure backup operation, this signal is not output.</p>
	<p>Pins for outputting the ACCELERATION state signal.</p> <p>These pins are closed when the STP pump is in acceleration.</p>

STP-301/451 Series Instruction Manual

<div style="display: flex; justify-content: space-between; align-items: center;"> (11) (24) </div> <div style="border: 1px solid black; padding: 5px; text-align: center; margin: 5px auto; width: 80%;"> NORMAL OPERATION N.O OUT </div>	Pins for outputting the NORMAL OPERATION state signal. These pins are closed when the STP pump is in rated operation.
<div style="display: flex; justify-content: space-between; align-items: center;"> (10) (22) </div>	Not used. (It corresponds to the pin for outputting the "BATTERY OPERATION " signal of the STP-200/300/400 series.)
<div style="display: flex; justify-content: center; align-items: center;"> (12) </div>	Not used. It is connected to the frame ground.

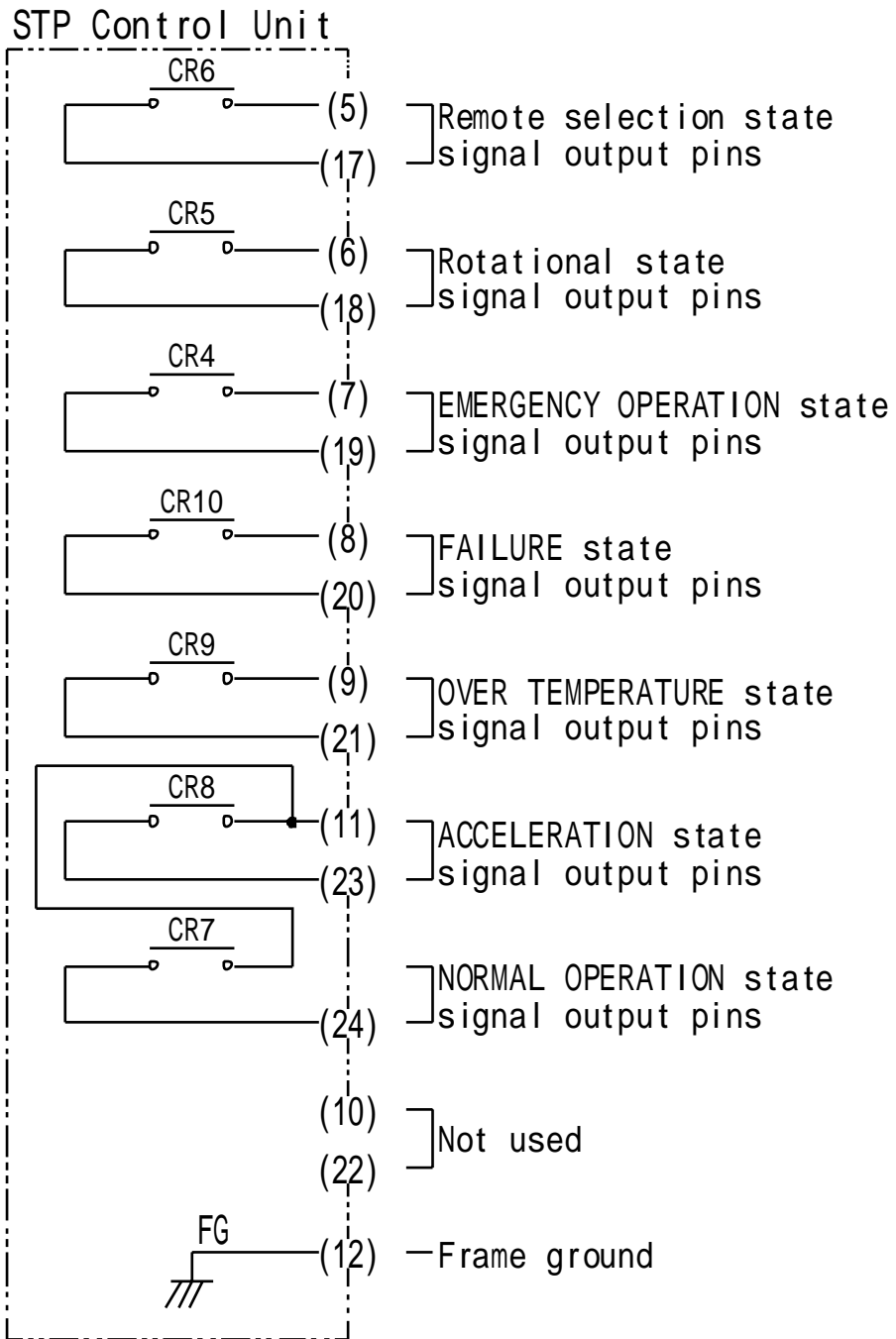

Figure 8.4 CON4 Remote Output Signal Connector

Table 8.8 shows rated contacts for relays CR4, 5, 6, 7, 8, 9 and 10. (see Figure 8.4)

Table 8.8 Rated Contacts for Relays CR4, 5, 6, 7, 8, 9 and 10

	Resistance Load (cos ϕ =1)		Induction Load (cos ϕ =0.4) (L/R=7 ms)	
Rated Load	125VAC 30VDC	0.4A 2A	125VAC 30VDC	0.2A 1A
Rated Current	3A			
Maximum Contact Point Voltage	250VAC 220VDC			
Maximum Contact Point Current	3A			
Maximum Open/Close Capacity	AC: 50VA DC: 60W		AC: 25VA DC: 30W	
Minimum Applicable Load	DC10mV 10 μ A			

8.3.3 Remote Cables (Optional Accessories)

Remote cables for CON4 are provided as optional accessories.

Remote cables are available in two types: single-side connector type and both-side connector type. Contact BOC Edwards for details.

Table 8.9 shows connections of remote cables of single-side connector type.

Table 8.9 Remote Cable Connections (Single-Side Connector Type)

Connector Pin No.	Cable Color	Connector Pin No.	Cable Color
1	Brown	13	White/Orange
2	Red	14	White/Yellow
3	Orange	15	White/Green
4	Yellow	16	White/Blue
5	Blue	17	Green
6	Purple	18	White/Black/Brown
7	Gray	19	White/Black/Red
8	White	20	White/Black/Orange
9	White/Black	21	White/Black/Yellow
10	White/Brown	22	White/Black/Green
11	White/Red	23	White/Black/Blue
12, hood	Shielded	24	White/Purple, White/Gray

9 Adjustment Method

9.1 Tuning

For the STP pump, tuning is required to align the position of levitation in the axial direction with the center of the rotor's movable range.

The tuning can be performed simply by pressing the "RESET" switch.

The tuning is completed before delivery, so it is not required before use. However, re-tuning is required in the following cases in which the position of levitation may deviate from the center of the rotor's movable range:

When changing the length of the STP connection cable (not when changing the length of the power cable)

When using the STP pump and STP control unit having different serial numbers

9.1.1 Tuning Method

- 1) Connect each cable.
- 2) Switch "ON" the breaker on the rear panel.
- 3) After the STP pump completes the self test and enter the levitation state, press the "RESET" switch on the front panel for approx. 3 seconds. The tuning starts with "TUNING!" displayed in the LCD.
- 4) When the LCD displays "TUNING!", release the "RESET" switch.
- 5) Approx. one minute later the LCD displays "TUNING COMPLETE" and returns to the message displayed in 3). This completes the tuning.



The tuning can be performed only when the STP pump is in the LEVITATION state. (It cannot be performed when the STP pump is in the ACCELERATION, NORMAL OPERATION, or BRAKE state.) Also, the tuning can be performed when any message of "LEVITATION", "RATING: ***00rpm", or "PUMP TEMP: **°C" is displayed.

When performing the tuning during remote operation, also use the "RESET" switch on the front panel. (The remote signal cannot be used for tuning.)

Once the tuning is completed, re-tuning is not required unless the configuration (the STP pump serial number, the STP control unit serial number, and the STP connection cable length) is changed.

Although the STP pump sounds during tuning, this is not an indication of abnormality.

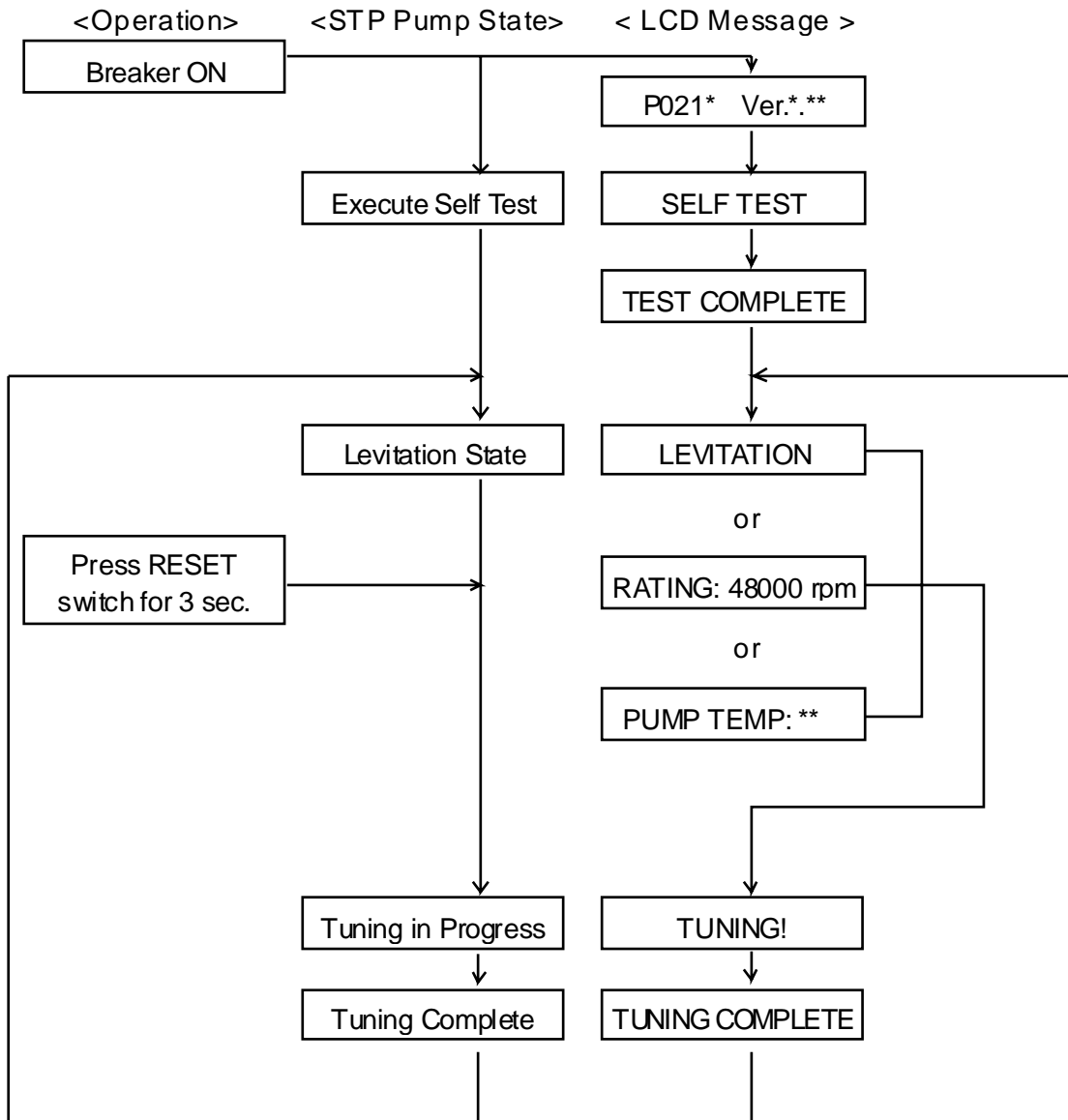

Figure 9.1 Tuning Procedures

9.2 Setting the Rated Speed

The STP pump can be set (changed) to the required rated speed in the range of 25,000 to 48,000 rpm, in units of 500 rpm. The setting can be performed even during rotation of the STP pump. The rated speed is set to 48,000 rpm at delivery.

The rated speed setting mode is entered by setting dip switch 1 of DSW-B on the top panel to the ON position.

The rated speed is set to 48,000 rpm (initial setting) by setting dip switch 1 to the OFF position.

For the position of the DSW-B switch, see Figure 6.3, "STP Control Unit Top Panel."

Prepare the following tool for setting the rated speed:

- Small-sized screwdriver

9.2.1 When Setting DSW-B No. 1 to ON under Power-ON State

- 1) Set dip switch 1 of DSW-B to the ON position.

The LCD displays "SET= ***00rpm," which indicates the rated speed setting mode. The speed displayed here depends on the current position dialed with the VR1 volume on the top panel.

- 2) Turning the VR1 volume on the top panel changes the value "***00rpm" on the rated speed setting display "SET= ***00rpm."

Turn the VR1 volume clockwise to increase the rated speed, or counterclockwise to decrease the rated speed, until the required rated speed is displayed.

Note that the rated speed is not yet determined in this state.

- 3) To determine the rated speed displayed in "SET= ***00rpm," press the "START" switch.

When the STP pump is in the ACCELERATION or NORMAL OPERATION state, it accelerates or decelerates up to the set value of rated speed.

When the STP pump is in the LEVITATION or BRAKE state, the pump's state remains unchanged.

Note that the rated speed is not determined if the "START" switch is pressed when the LCD message is other than "SET= ***00rpm."

- 4) Press the "SELECT" switch once, and the LCD displays the set value of rated speed in "RATING: ***00rpm." Make sure the required rated speed is displayed.

If the required speed is not displayed or the rated speed is to be changed again, press the "SELECT" switch to display "SET= ***00rpm" again. Then, perform steps 2) and 3) again to set the rated speed.

- 5) When the STP pump is in the LEVITATION or BRAKE state, perform STP pump rotation operation to rotate it. The STP pump accelerates up to the rated speed.

9.2.2 When Setting DSW-B No. 1 to ON before Powering On

- 1) Set dip switch 1 of DSW-B to the ON position.
- 2) Switch "ON" the breaker on the rear panel.
After the STP pump completes the self test, the LCD displays the current rated speed in "RATING: ***00rpm." The rated speed displayed here is the previously set rated speed (or initial rated speed 48,000 rpm).
- 3) Press the "SELECT" switch three times to display "SET= ***00rpm," which indicates the rated speed setting mode.
- 4) Turning the VR1 volume on the top panel changes the value "***00rpm" on the rated speed setting display "SET= ***00rpm."
Turn the VR1 volume clockwise to increase the rated speed, or counterclockwise to decrease the rated speed, until the required rated speed is displayed.
Note that the rated speed is not yet determined in this state.
- 5) To determine the rated speed displayed in "SET= ***00rpm," press the "START" switch.
Note that the rated speed is not determined if the "START" switch is pressed when the LCD message is other than "SET= ***00rpm."
- 6) Press the "SELECT" switch once, and the LCD displays the set value of rated speed in "RATING: ***00rpm." Make sure the required rated speed is displayed.
If the required rated speed is not displayed or the rated speed is to be changed again, press the "SELECT" switch to display "SET= ***00rpm" again. Then, perform steps 4) and 5) again to set the rated speed.
- 7) Perform STP pump rotation operation to start the STP pump. The STP pump accelerates up to the rated speed.

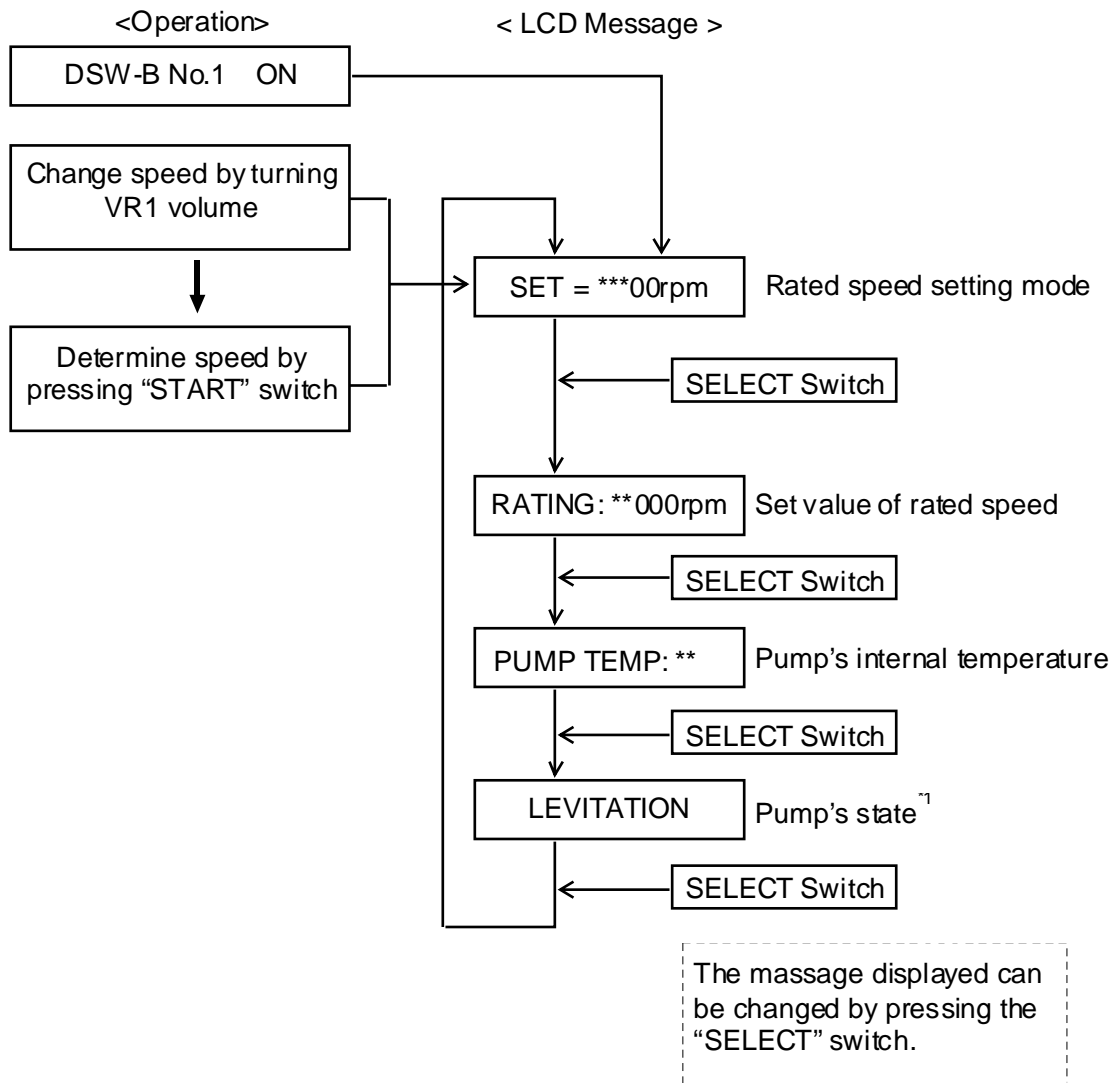

NOTICE

The rated speed returns to 48,000 rpm (initial setting) by setting dip switch 1 of DSW-B to "OFF."

Figure 9.2 LCD Message in Rated Speed Setting Mode

*1: The STP pump's state displayed depends on the pump's operation state.

- Examples)
- "LEVITATION" (LEVITATION state)
 - "ACCEL: ***00rpm" (ACCELERATION state)
 - "NORMAL: ***00rpm" (NORMAL OPERATION state)
 - "BRAKE: ***00rpm" (BRAKE state)

10 Safety Functions

10.1 Power Failure

<Operation at a Power Failure>

When the power voltage drops below 170 V (in case of 200 V specification) or below 85 V (in case of 100 V specification) due to power failure, the normal operation of the magnetic bearing is maintained using the regenerative energy of the rotating rotor (backup operation during a power failure).

- 1) When the rotational speed is 25,000 rpm or more at a power failure:
 - I. The STP control unit detects any power failure of 2 seconds or more and the STP pump decelerates.

At this time, the "POWER" lamp goes out and the "FAILURE" lamp lights. The LCD displays "POWER FAILURE." Also, an alarm signal is output from I/O TB1 ALARM OUT terminals (10)-(9) and (10)-(11).
When the number of rotations goes down to 20,000 rpm, the backlight of the LCD goes out and the alarm signal output is reset.
When the number of rotations goes down to approx. 17,000 rpm, the rotor lands on the touch down bearing and stops. The "FAILURE" lamp goes out and the LCD is turned off.
 - II. The STP control unit does not detect a power failure of less than 2 seconds, continuing rotating the STP pump.
- 2) When the rotational speed is 17,000 rpm or more and less than 25,000 rpm at a power failure:

The STP control unit detects a power failure of approx. 0.02 to 0.14 seconds and the STP pump decelerates.

At this time, the "POWER" lamp goes out and the "FAILURE" lamp lights. The LCD displays "POWER FAILURE". Also, an alarm signal is output from I/O TB1 ALARM OUT terminals (10)-(9) and (10)-(11).
However, when the number of rotations is less than 20,000 rpm at the occurrence of a power failure, no alarm signal is output.
When the number of rotations goes down to 20,000 rpm, the backlight of the LCD goes out and the alarm signal output is reset.
When the number of rotations goes down to approx. 17,000 rpm, the rotor lands on the touch down bearing and stops. The "FAILURE" lamp goes out and the LCD is turned off.



A power failure is detected faster the less the rotational speed at the power failure.

- 3) When the rotational speed is less than approx. 17,000 rpm at a power failure:

The STP control unit does not detect the power failure; the rotor lands on the touch down bearing and stops.

1) MANUAL operation

The STP pump continues decelerating even after a power recovery. Press the "START" switch to reaccelerate the STP pump.

2) REMOTE operation

- When the START signal is input to the REMOTE input terminal at a power recovery to reaccelerate the STP pump.
- When the START signal is not input to the REMOTE input terminal after a power recovery, the STP pump continues the BRAKE operation.



Establish a sequence so that the power can be supplied to the STP control unit immediately after a power recovery.

Table 10.1 shows the states of lamps and the REMOTE output signals at a power failure. Also, Table 10.2 shows the operations of the STP pump after a power recovery.

Table 10.1 States of Lamps and REMOTE Output Signals at Power Failure

Rotational speed (rpm)	LCD		LED lamps		REMOTE output signals (I/O TB1)	
	Message	Backlight	POWER lamp	FAILURE lamp	Power ON signal	ALARM signal
20,000 or more	POWER FAILURE	ON	OFF	ON	OFF	ON
17,000 or more and less than 20,000	POWER FAILURE	OFF	OFF	ON	OFF	OFF
Less than 17,000	OFF	OFF	OFF	OFF	OFF	OFF

Table 10.2 Operations of the STP Pump after Power Recovery

Rotational speed (rpm)	Duration of power failure	MANUAL operation	REMOTE operation	
		STP pump operation after power recovery	"START" REMOTE signal input after power recovery	STP pump operation after power recovery
25,000 or more	Approx 2 sec or longer	Deceleration/Stop	Yes	Reacceleration
			No	Deceleration/Stop
	Shorter than approx 2 sec	Continues as before.		
Less than 25,000	Approx 0.02 to 0.14 sec ^{*1}	Deceleration/Stop	Yes	Reacceleration
			No	Deceleration/Stop
	Shorter than the above	Continues as before.		

*1: A power failure is detected faster the less the number of rotations at the power failure.

10.2 Abnormal State of Magnetic Bearing

When the magnetic bearing does not function normally due to a breakage of the STP connection cable, disconnection of connectors or any abnormality/error of the STP control circuit, the rotor falls on the touch down bearing and stops.

Simultaneously, the "FAILURE" lamp lights and the LCD displays error message "DISTURBANCE."



When an abnormality/error occurs in the magnetic bearing, check the STP pump as well as the STP control unit, and contact service office.

10.3 Excessive Vibration

When serious vibration or mechanical shock causes the rotor to touch the touch down bearing (due to external vibration/impact, intrusion of atmosphere or foreign particles into the STP pump or rotor imbalance), the STP pump decelerates and stops.

Simultaneously, the "FAILURE" lamp lights and the LCD displays error message "DISTURBANCE."

10.4 Motor Driver Overload

When the STP pump does not attain the rated speed within approx. 10 minutes after starting or when the ACCELERATION state remains unchanged during operation for approx. 10 minutes, the STP pump decelerates and stops. Simultaneously, the "FAILURE" lamp lights and the LCD displays error message "OVERLOAD."

10.5 Overheating Inside the STP Pump

When the temperature of the motor inside the STP pump exceeds 110°C due to an abnormal baking temperature or overload operation, the STP pump decelerates and stops.

Simultaneously, the "FAILURE" lamp lights and the LCD displays error message "PUMP OVERTEMP."

10.6 Overheating Inside the STP Control Unit

When the temperature inside the STP control unit exceeds 70°C due to a failure in the air cooling fan, external heat source, and other, the STP pump decelerates and stops.

Simultaneously, the "FAILURE" lamp lights and the LCD displays error message "CONTROLLER OT."

10.7 Overspeed

STP-301/451 Series Instruction Manual

When the rotational speed of the STP pump exceeds 51,400 rpm due to a failure in the motor driver, the breaker in the STP control unit switches "OFF." The STP pump has no power supplied and stops.

Simultaneously, the "FAILURE" lamp lights and the LCD displays error message "OVERSPEED" or "DRIVERRA".

Table 10.3 Safety Functions

Abnormality /Error	Operation state of safety functions	Lamp indication	LCD	REMOTE output signal	State of the STP pump	Probable causes of an abnormality/error	Reset by RESET operation
Power failure	Power failure time: 2 seconds or longer.	"FAILURE" lights. "POWER" goes out.	"POWER FAILURE"	"ALARM" "POWER ON" output cut-off	The magnetic bearing continues to operate using regenerative energy. The STP pump decelerates and stops. The rotor lands on the touch down bearing at approx. 17,000 rpm.	Power failure. Power cable breakage. Power cable disconnection.	Impossible
Abnormal magnetic bearing	Rotor descends onto the touch down bearing.	"FAILURE"	"DISTURBANCE"	"ALARM"	The rotor stops on the touch down bearing.	STP connection cable breakage. STP connection cable disconnection. Abnormal control circuit.	Possible
Excessive vibration	Rotor vibration: 100 μm 0-P or more.	"FAILURE"	"DISTURBANCE"	"ALARM"	The STP pump decelerates and stops.	External vibration, and impact. Intrusion of atmospheric air. Intrusion of foreign particles.	Possible

STP-301/451 Series Instruction Manual

Abnormality /Error	Operation state of safety functions	Lamp indication	LCD	REMOTE output signal	State of the STP pump	Probable causes of an abnormality/error	Reset by RESET operation
Overload of motor driver	Excessive current flows in the motor.	"FAILURE"	"OVERLOAD"	"ALARM"	The STP pump decelerates and stops.	Leakage from the vacuum equipment or piping. Insufficient pressure at inlet and outlet port sides. Failure of starting of the backing pump.	Possible
Overheating inside the STP pump	Temperature of the STP pump motor: 110 or more.	"FAILURE"	"PUMP OVERTEMP"	"ALARM"	The STP pump decelerates and stops.	Abnormal baking temperature. Insufficient cooling. Leakage of vacuum equipment or piping. Continuous repetition of startup/stop. Extraordinarily-high temperature.	Possible
Overheating inside the STP control unit	70 or more inside the STP control unit.	"FAILURE"	"CONTROLLER OT"	"ALARM"	The STP pump decelerates and stops.	Failure in the cooling fan. Shielding of cooling air inlet and ventilation port. Extraordinarily-high temperature.	Possible
Overspeed	Rotational speed of the STP pump: 51,400 rpm or more.	"FAILURE"	"OVERSPEED" or "DRIVER RA"	"ALARM"	Breaker OFF. Power failure state. The STP pump stops.	Failure in the motor driver.	Impossible

11 Troubleshooting, Maintenance and Inspection

The STP pump is provided with safety functions for various abnormalities/errors. When an abnormality occurs in the STP pump or STP control unit, a safety function operates with the "FAILURE" lamp lit, and an alarm signal is output from remote output terminals. Also, the LCD displays an error message.

If an abnormality/error is found when using the STP pump, check it and take measures in accordance with the following procedures.

If you cannot trace it or if the STP pump does not function normally after the troubleshooting, fill in the necessary information in the "Malfunction Information" and fax it to Service office.



After confirming that the STP pump stops thoroughly, turn OFF the primary power (switch the breaker "OFF"), check probable causes and remove them.

11.1 Troubleshooting Immediately After An Abnormality/Error Occurs

11.1.1 In Case of a Power Failure:

Establish a sequence so that the power can be supplied to the STP control unit immediately after a power recovery.

11.1.2 In Other Cases

- 1) After confirming the "BRAKE" lamp goes out and the STP pump stops, remove the probable cause of the abnormality.
- 2) Perform the RESET operation according to turn off the "FAILURE" lamp.
- 3) Perform the START operation. Check if the STP pump operates correctly.



When disconnecting cables from the STP pump and/or the STP control unit to perform troubleshooting and take the necessary action, confirm that the STP pump stops, switch OFF the primary power (breaker "OFF"), then disconnect the cables.

If the RESET operation does not turn off the "FAILURE" lamp, confirm that the STP pump stops, switch OFF the primary power (breaker "OFF"), then switch "ON" the primary power again (breaker "ON").

11.2 When Error Message is Displayed

11.2.1 Error Messages

When an abnormality occurs, the "FAILURE" lamp lights and the LCD displays an error message.

If an ampersand "&" is shown at the right of the error message, it indicates that more than one error occurs. In this case, press the "SELECT" switch to display another error message.

(The "SELECT" switch can also be used during remote operation.)

Example)

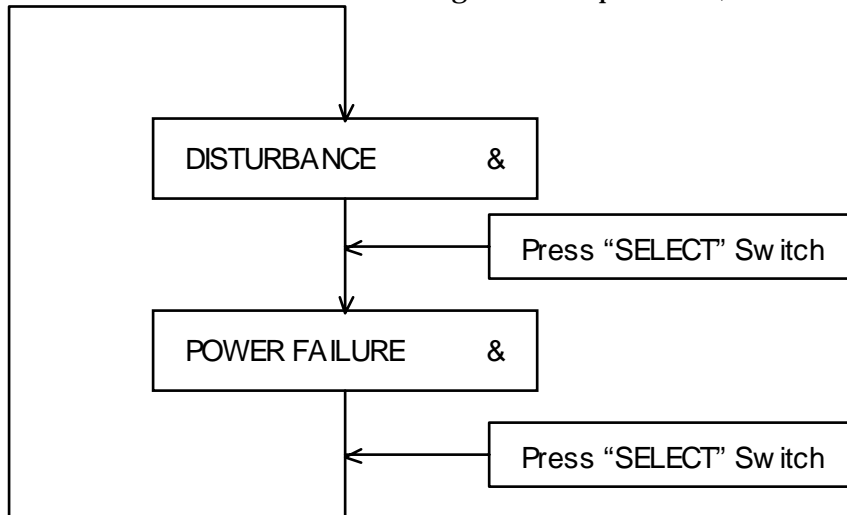

Table 11.1 Error Messages

LCD Message	Probable Cause	Countermeasures	Refer to
CABLE DISCONNECT	Incorrect connection of the STP connection cable	Connect the cable correctly. If the cable connector is not locked, lock it securely.	6.4.2
	Failure of the STP connection cable	Contact Service office.	Malfunction Information
CONTROLLER OT	Overheating inside the STP control unit		
	1) Ambient temperature 2) Insufficient cooling of the STP control unit	1) Set the ambient temperature to 40°C or less. 2) Remove obstacles from the ventilation port. If the air cooling fan is broken, contact Service office.	6.2.1 6.2.3 11.3.1
DISTURBANCE	Abnormal magnetic bearing		
	1) The STP pump and the STP control unit have different serial numbers. 2) The cable length is changed.	1) Use the units having the same serial number, or perform tuning. 2) Perform tuning.	9.1 9.1
	Excessive external vibration (vibration of 100 μ m0-P or more)		
	1) External vibration/impact	1) Remove the external vibration so as not to transmit it to the STP pump.	4.3.4
	2) Atmospheric air flows into the STP pump	2) Check piping.	4.3.4
	3) Foreign particles fall into the STP pump	3) Install the pump in a way that no foreign particles fall into the pump.	4.3.1
DRIVER ERROR 1 DRIVER ERROR 2 DRIVER ERROR 3 DRIVER ERROR 4 DRIVER ERROR	Motor driver failure	Contact Service office.	Malfunction Information

LCD Message	Probable Cause	Countermeasures	Refer to
5 DRIVER ERROR 6			
DRIVER HF	Hall sensor error	Contact Service office.	Malfunction Information
DRIVER OC	Motor driver overcurrent	Contact Service office.	
DRIVER OV	Motor driver overvoltage	Contact Service office.	
DRIVER RA	STP pump overspeed (detected in the range of 49,500 to 53,000 rpm)	Contact Service office.	
DRIVER UV	Motor driver undervoltage	Contact Service office.	

OVERLOAD	Motor driver overload 1) Insufficient pressure at the inlet port 2) Insufficient pressure at the outlet port 3) Leakage of the piping system 4) Failure of the backing pump	1) Use the maximum working pressure or less. 2) Use the allowable backing pressure or less. 3) Check the piping system. 4) Check the backing pump for its capacity and start state. (use a pump with the recommended capacity or more)	4.3.4 13.1 4.3.4 13.1 4.3.4 4.3.4 13.1
OVERSPEED	STP pump overspeed (detected at over 51,400 rpm)	Contact Service office.	Malfunction Information
POWER FAILURE	Power supply failure 1) Power failure 2) Incorrect connection of power cable 3) Power cable breaking 4) Abnormal power voltage	1) Check whether or not a power failure has occurred. 2) Connect the power cable correctly. 3) Replace the power cable. 4) Set the voltage to 100 to 120V +/-10% (100V spec.) or to 200 to 240V +/-10% (200V spec.).	10.1 6.4.2 6.4.2 6.4.2
PUMP OVERTEMP	Overheating inside the STP pump 1) Overheating during baking	1) Set the temperature of baking heater to 120°C or lower.	5.1

LCD Message	Probable Cause	Countermeasures	Refer to
	2) Insufficient cooling	2) At the time of baking or gas suction, always cool the STP pump.	5.2
	3) Leakage of the vacuum piping system	3) Check the piping system for leakage.	4.3.4
	4) Repetitious start/stop operations	4) Repetitious start/stop operations may cause the overheat.	7.2
RAM ERROR	Microcomputer sequence circuit failure	Contact Service office.	Malfunction Information
THERMAL ERROR	Incorrect connection of the STP connection cable	Connect the cable correctly. If the cable connector is not locked, lock it securely.	6.4.2
	STP connection cable failure	Contact Service office.	Malfunction Information
	Thermal sensor wire breaking inside the STP pump	Contact Service office.	
TEST ERROR	Abnormal end of self test	Contact Service office.	Malfunction Information
TUNING ERROR 1 TUNING ERROR 2 TUNING ERROR 3 TUNING ERROR 4 TUNING ERROR 5	Tuning error	Contact Service office.	Malfunction Information

11.2.2 Displaying Past Abnormalities/Errors and Accumulated Running-Time

(This function is available with the STP pump of "Ver. 2.20" and after. How to check the version is shown on the next page.)

The STP pump provides a function that the LCD displays a maximum of eight error messages that occurred in the past, and a total of running-time in hours (acceleration, rated speed operation, and deceleration).

<How to display error messages>

- 1) Press and hold the "SELECT" switch for approx. 3 seconds or more when the LCD displays a pump's state message. The LCD displays the accumulated running time and then error messages that occurred in the past (error record display mode). The number displayed at the right of the error message is an error sequence number. The smaller number indicates that the error occurred more recently.
- 2) To return to the previous pump's state message, press and hold the "SELECT" switch again for approx. 3 seconds or more, or leave the error message displayed for approx. 20 seconds without pressing the "SELECT" switch.

< LCD Message >

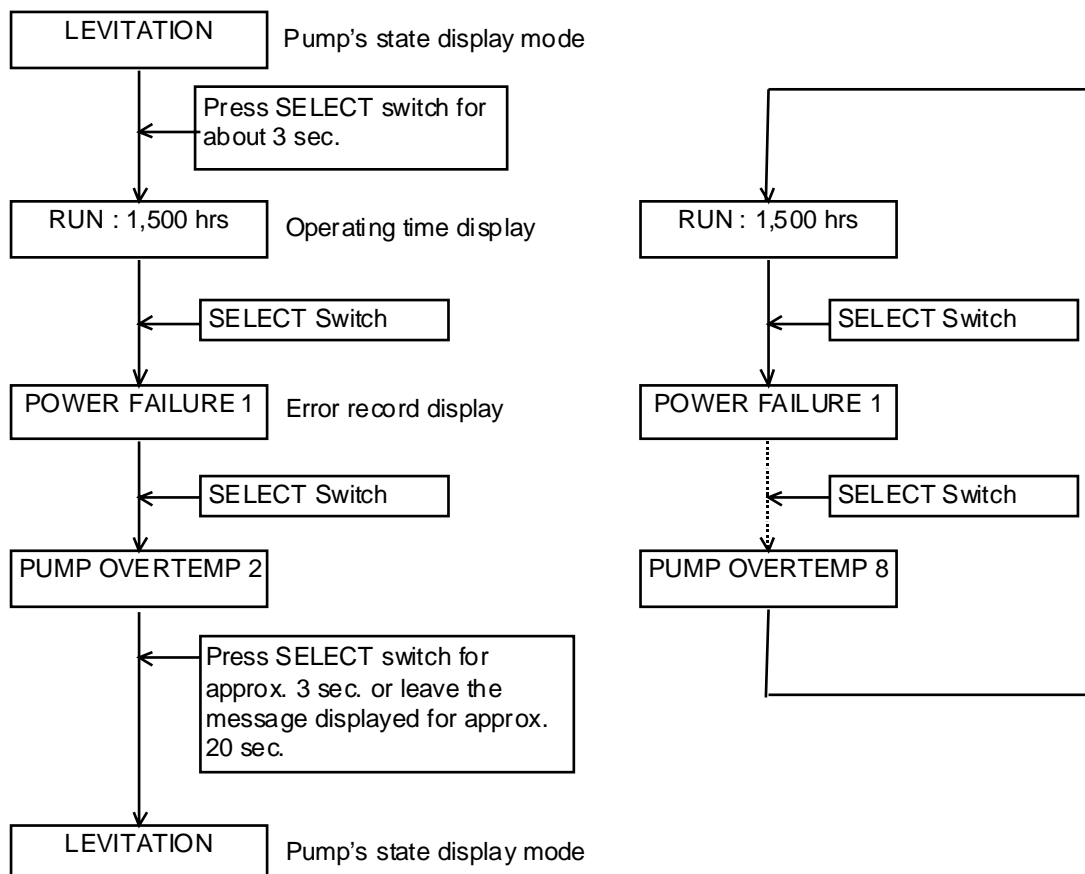

Switching display between state message and error record message

Changing display in error record display mode

<How to check the version>

The version of the STP pump is displayed on the LCD immediately after the main breaker is switched "ON."

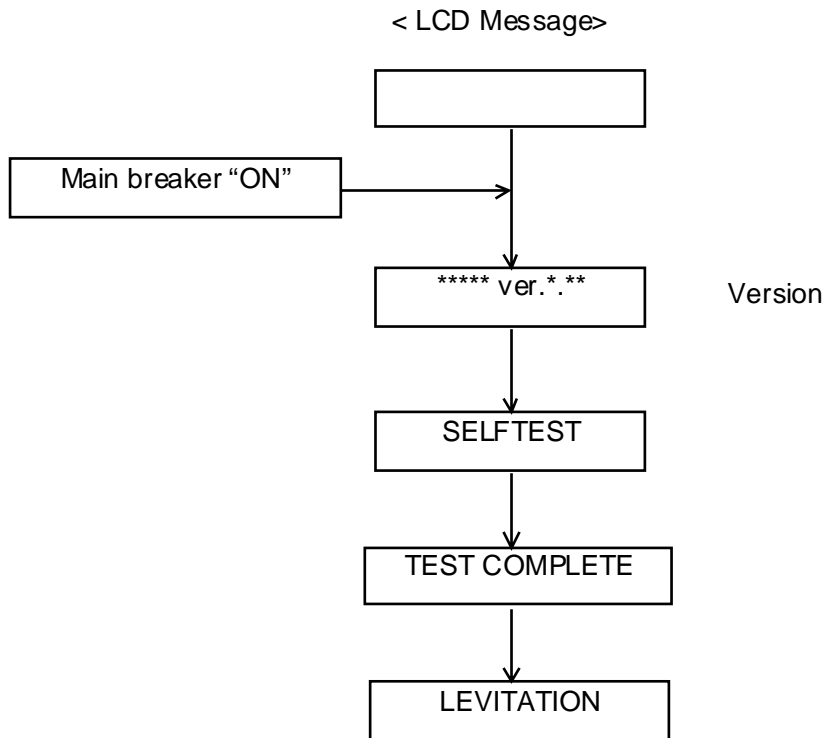

11.2.3 Abnormalities When Powering ON

Table 11.2 Troubleshooting after Powering ON

Symptom	Probable cause	Countermeasures	Refer to
The "POWER" lamp does not light, when powering ON.	Incorrect connection of the power cable	Connect the power cable correctly.	6.4.2
	Abnormal power voltage	Set the voltage to 100 to 120V +/-10% (100V spec.) or 200 to 240V +/-10% (200V spec.).	6.4.2 13.2
	Power failure	Check whether or not a power failure has occurred.	10.1
The breaker goes OFF when powering ON.	Abnormal power voltage (200V is applied to the STP control unit of 100V spec.)	Set the voltage to 100 to 120V +/-10%.	6.4.2 13.2

11.2.4 Abnormalities When Performing the STP Pump Start Operation

Table 11.3 Troubleshooting When Performing the STP Pump Start Operation

Symptom	Probable causes	Countermeasures	Refer to
The "ACCEL." lamp does not light.	LCD message (MANUAL operation only)	Press the "SELECT" switch one or more times until the LCD displays "LEVITATION" or "BRAKE ***00rpm."	7.4.2
	The "MANUAL/REMOTE" changeover switch is not at the correct position.	Slide the "MANUAL/REMOTE" changeover switch to the correct position.	6.1.1 7.4 7.5
	Blown fuses (F1 to 4) for remote signal input (REMOTE operation only)	Replace the blown fuses. Contact Service office.	8.2 Malfunction Information
	Incorrect setting of DSW-B No.4 (only with CON4)	Set the DSW-B No.4 to either "ON/OFF" according to the remote input connector/terminal.	6.1.3 7.5/7.6 8.2/8.3

11.2.5 Other Abnormalities

Table 11.4 Troubleshooting While the STP Pump is Rotating

Symptom	Probable causes	Countermeasures	Refer to
The STP pump stops.		Check the past errors referring to Section 11.2.2, "Displaying Past Abnormalities/Errors and Accumulated Running Time."	11.2.2
Insufficient ultimate pressure	Failure of the backing pump	Check the backing pump for its capacity and start state. (use a pump with the recommended capacity or more)	4.3.4 13.1
	Leakage of the piping system	Check the piping system for leakage.	4.3.4
	Residual molecules	If the main composition is H ₂ or H ₂ O, perform baking; if it is other than H ₂ or H ₂ O, clean the inside of the vacuum equipment. (If gases remain inside the STP pump, contact Service office when it is needed to be cleaned.)	5.1 11.3.5

11.3 Maintenance and Inspection



When performing maintenance and inspections of the STP pump, exhaust gases inside the STP pump thoroughly.

Residual gases may cause an accident when removing the STP pump.

Confirm the characteristics of gas to be used, referring to the Material Safety Data Sheet (MSDS) you obtain from the gas supplier.

Wear personal protective equipment if necessary.



Stop the STP pump, and turn OFF the primary power (switch the breaker "OFF"), before performing maintenance of the STP control unit (such as fuse replacement).

Failure to do so may result in an accident such as an electric shock.

Stop the STP pump, and turn OFF the primary power (switch the breaker "OFF"), before performing inspections of the STP pump (for deposit).

Failure to do so may result in the inadvertent rotation of the STP pump, which may result in an accident.

Do not touch any place other than those specified when performing maintenance or inspecting the pump and NEVER open any panel because it could cause shock, malfunction, or short circuit.

Power OFF the baking heater and the air cooling unit, before performing maintenance or inspections.

The wipes used for clean and decontamination might become hazardous waste depending upon the solvent (alcohol). Dispose of the contaminated wipes appropriately according to the regulations of each national and/or local government.

11.3.1 Inspecting the Air Cooling Fan

Turn ON the primary power (switch the breaker "ON").

Confirm that the air cooling fan at the STP control unit side panel (left) is operating.

If the air cooling fan is not operating, contact Service office to replace it.

It is recommended to inspect the air cooling fan once a year.

11.3.2 Replacing the Fuses



Remove the probable causes of the blown fuse (Ex. a problem with the remote input signal, and other) before replacing the fuse.
Always use specified and rated fuses.
When you use parts other than those recommended in the above table, contact Service Office.



If fuses are blown frequently even after they are replaced, contact Service office.
Two fuses are attached for replacement.

The following are protective fuses used in the STP control.

F1, F2: 250 V, 10 A

For I/O TB1 remote input/output terminal protection.

For power input (1) and (2) and power output (3) and (4) protection.

Table 11.5 Recommended Spare Parts

Product name	Type	Specifications
Fuses for F1, F2	MF60-NR10 10A, 250 V (Mfr.: TOYO FUSE CO., LTD)	10A, 250 V, Normal acting type 6.35 × 30 mm

11.3.3 Cleaning and Decontamination

The method of cleaning and decontamination of the STP pump and STP control unit is shown below.

Table 11.6 Cleaning and Decontamination

Area		Cleaning and Decontamination
STP Pump	Exterior	Wipe with proper solvent (such as alcohol). Clean off with a pure gas when dust has accumulated in the connector. When the label of the STP pump has been damaged, contact Service office.
	Interior	The decontamination (overhaul) in the STP pump is executed in Service office. When overhaul is needed, contact Service office.
STP Control unit	Exterior	Wipe with proper solvent (such as alcohol). When dust has accumulated in the ventilation port, wipe off or vacuum it with the cleaner. In this case, dust must not enter in the STP control unit. Clean off with a pure gas when dust has accumulated in the connector. When the label of the STP control unit has been damaged, contact Service office.
	Interior	The cleaning (overhaul) in the STP control unit is executed in Service office. When overhaul is needed, contact Service office.

11.3.4 Inspecting for Deposit

Leaving the STP pump without removing the deposit may cause the STP pump to be corroded beyond repair.

Deposit may have accumulated inside the STP pump depending upon the type of the vacuum equipment installed to the STP pump.

An increase in the amount of deposit may lead to a malfunction of the STP pump.

Therefore, perform regular maintenance (once every 3 to 6 months).

Inspect the inside of the outlet port flange for adhesion of deposit while watching the outlet port flange. If deposit has accumulated to some extent, an overhaul (cleaning) is required.

Contact Service office.

Note that the costs of troubleshooting problems resulting from deposit will be at your own charge even during the warranty period.

If a problem resulting from deposit occurs inside the STP pump, hermetically seal the inlet port, outlet port, purge port, and leak port flanges, and immediately return the pump to Service office.

For the transport method, see Section 11.3.6, "Transporting for Repair or Overhaul."

NOTICE

Contact with atmospheric air may cause a reaction of the deposit. DO NOT open the STP pump to atmospheric air as much as possible.

11.3.5 Overhaul

The recommended maintenance intervals for different process applications are tabulated below:

	Process	Period	Remarks
Etching*1	Metal Etch	1 year	Ensure that TMS (Temperature Management System) is fitted and operational to prevent accumulation of by-product deposition in the pump.
	Other Etch Processes	2 years	
	It is recommended to change the pump rotor after 5 years due to accumulated wear of the protective plating material		
	Other semiconductor process	2 years	Processes resulting in accumulation of deposits in the pump will require more frequent service.
	Clean applications (Only vacuum pumping)	5 years	
	Other use	(2 years)	Dependent on application, contact BOC Edwards.



The touch down bearing inside the STP pump will be worn out after a number of full speed touch downs.

The costs of replacing parts that need to be replaced because of deterioration or abrasion will be at your own charge.

When overhaul of the STP pump or the STP control unit is needed, contact Service office.

*1 "Etching" includes semiconductor etching and LCD etching.

11.3.6 Transporting for Repair or Overhaul



When returning the STP pump which has used any kind of gases to Service office, fill the type of gas and handling precautions in the "Malfunction Information" and fax it to Service office.

Confirm the characteristics of gas to be used, referring to the Material Safety Data Sheet (MSDS) you obtain from the gas supplier.

Follow the instruction of "Return Procedure" to prevent an accident during the transportation, repair or overhaul.



When returning the STP pump to Service office, be sure to pack it well to prevent external damage.

If "Return Procedure" has not been satisfied, BOC Edwards will not be responsible for any troubles.

i) Always contact Service office before returning the STP pump for repairs, overhaul, or other purposes. To avoid any accident by gases or corrosion inside the STP pump, particularly when corrosive, reactive or flammable gases have been used, ii) Vacuum and hermetically seal the STP pump before transport. iii) Specify the type of gases used and handling precautions in the "Malfunction Information" and return the STP pump to Service office.

When returning the STP pump to Service office, be sure to pack it well to prevent external damage. Use similar or superior packaging material as originally supplied.

"Return Procedure" and the "Malfunction Information" are in the end of the Instruction Manual. When additional sheet is needed, contact Service office.



The costs of cleaning and overhaul of the STP pump will be at your own charge. When returning the STP pump to Service office, fill in the necessary items in the "Malfunction Information" and fax it to Service office.

12 Storage and Disposal

12.1 Storage of the STP Pump

When the STP pump is left unused over a long period (more than a few months), follow the precautions below:

- 1) Close the inlet port of the STP pump and vacuum it using an auxiliary pump.
- 2) Introduce dry N₂ gas or dry air from the outlet port or the purge port.
- 3) Close the outlet port and purge port.
- 4) If the STP pump is water cooled, introduce compressed air from one side of the cooling water port so that no water remains in the STP pump.
- 5) Store the STP pump in a vertical position.
- 6) DO NOT store the STP pump in the following places:
 - Place of high humidity.
(If it must be stored in a place of high humidity, insulate it from the outside and use a dehumidifying agent.)
 - Place of high temperatures (more than +55°C) and low temperatures (less than -25°C).
 - Place where there are corrosive gases.
 - Place subjected to dripping water.
 - Place with a lot of dust.
 - Place with insufficient ventilation.
 - Place subjected to strong magnetic or electric fields.
 - Place subjected to radiation.

12.2 Storage of the STP Control Unit

If the STP control unit (including cables) is not used for a long period (more than a few months), follow the precautions below:

- 1) Store the STP control unit in a horizontal position.
- 2) DO NOT store the STP control unit in the following places:
 - Place of high humidity.
(If it must be stored in a place of high humidity, insulate it from the outside and use a dehumidifying agent.)
 - Place of high temperatures (more than +55°C) and low temperatures (less than -25°C).
 - Place subjected to direct sunlight.
 - Place where there are corrosive gases.
 - Place subjected to dripping water.
 - Place with a lot of dust.
 - Place of insufficient ventilation.
 - Place subjected to strong magnetic or electric field.
 - Place subjected to radiation.
 - Place subjected to mist.
 - Place with electric noise.
 - Place with vibration.

12.3 Disposal

Dispose of the STP pump and the STP control unit as **industrial waste** according to the guidelines given by each national and/or local government.



When disposing of the STP pump, exhaust gases inside the STP pump thoroughly. Residual gases may result in an accident when disposing of the STP pump. If the STP pump has been used with reactive or corrosive gasses, always clean thoroughly before disposing of it to avoid any injury. Confirm the characteristics of gas to be used, referring to the Material Safety Data Sheet (MSDS) you obtain from the gas supplier.



BOC Edwards is not responsible for problems during or after disposal.

13 Specifications and Accessories

13.1 Specifications of the STP Pump

Table 13.1 Specifications of the STP Pump

Item		STP-301 series	STP-451 series
Flange size* ¹	Inlet port flange	ICF152/VG100/ISO10 0	ICF203/VG150/ISO16 0
	Outlet port flange	KF25	
Pumping speed* ²	N ₂ L/s	300	480
	He L/s	280	460
	H ₂ L/s	300	460
Compression ratio	N ₂	>10 ⁸	
	He	5 x 10 ⁵	
	H ₂	2 x 10 ⁴	
Ultimate pressure Pa (Torr)	Without anti-corrosion treatment	10 ⁻⁸ (10 ⁻¹⁰) : ICF flange 6.5 x 10 ⁻⁶ (5 x 10 ⁻⁸) : VG/ISO flange	
	Chemical specific type	10 ⁻⁷ (10 ⁻⁹) : ICF flange 6.5 x 10 ⁻⁶ (5 x 10 ⁻⁸) : VG/ISO flange	
Maximum working pressure	Pa (Torr)	6.7 x 10 ⁻² (5 x 10 ⁻⁴) : Natural air cooling	
Allowable backing pressure	Pa (Torr)	13 (0.1) : Natural air cooling	
Rated speed	rpm	25,000 to 48,000	
Starting time	min	3	
Stopping time	min	3	
Vibration	μ m O-P	<0.01 (at 48,000 rpm)	
Noise	dB	<50 (at 48,000 rpm)	
Baking temperature	°C	<120	
Lubricating oil		Not necessary	
Installation position		Free	
Cooling method		Natural air cooling (Water/air cooling: for baking/gas suction)	
Standard backing pump	L/min	240	
Mass	kg	11	12
Dimensions	mm	180x230	180x200
Ambient temperature range	°C	0 to 40	
Storage temperature range	°C	- 25 to + 55	

The values shown in the table are typical; they are not guaranteed.

*¹: ICF (JVIA standard), VG, KF (JIS)

*²: At 48,000 rpm. The performance varies with the rated speed

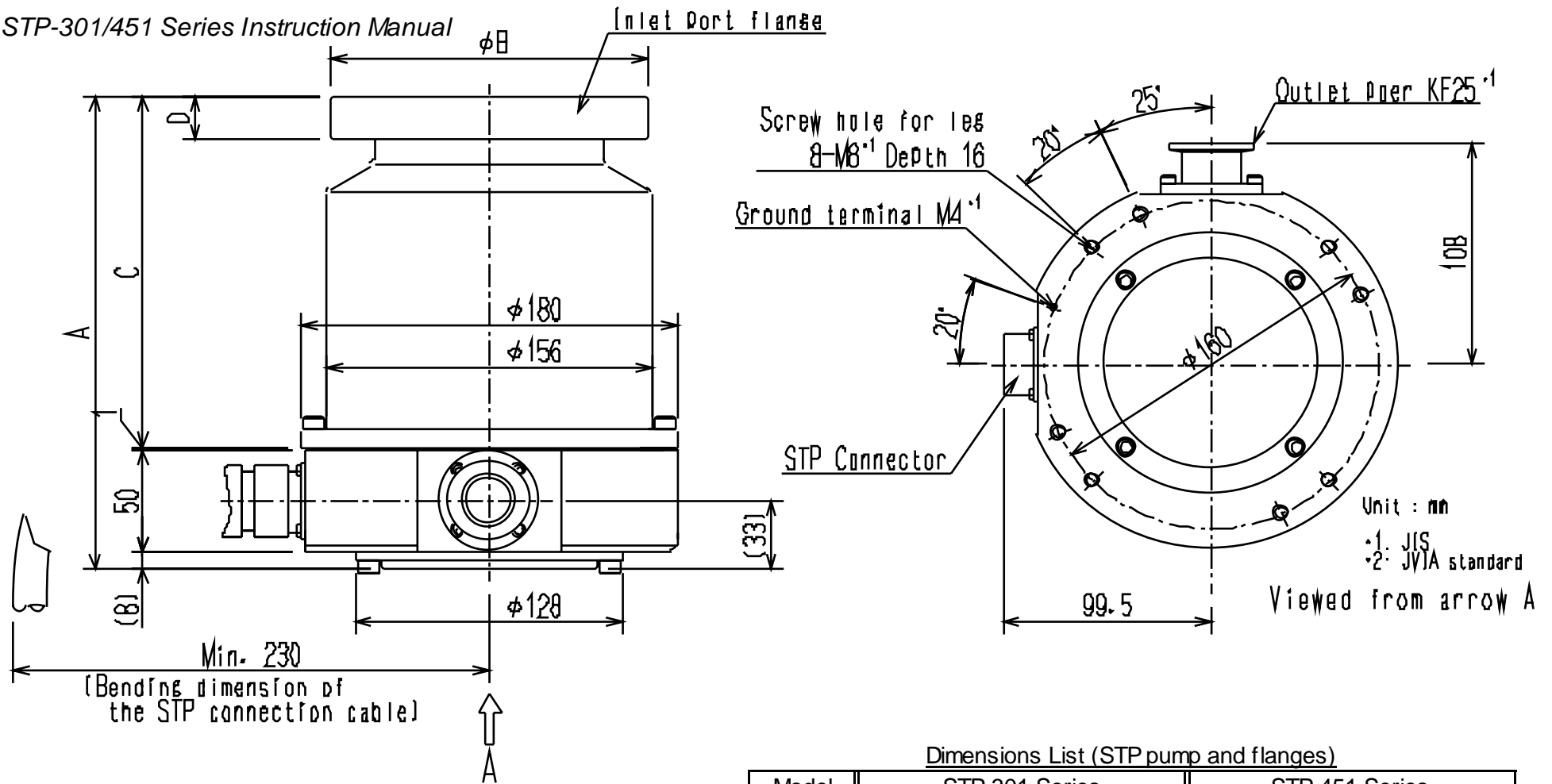

Dimensions List (STP pump and flanges)

Model	STP-301 Series			STP-451 Series		
	ICF ^{*2} 152	VG ^{*1} 100	ISO100	ICF ^{*2} 203	VG ^{*1} 150	ISO160
A	230	230	230	200	200	200
B	152	185	130	203	235	180
C	171	171	171	141	141	141
D	21	12	12	22	12	12

Figure 13.1 External Appearance of the STP Pump [without Anti-Corrosion Treatment] (Example: STP-301)

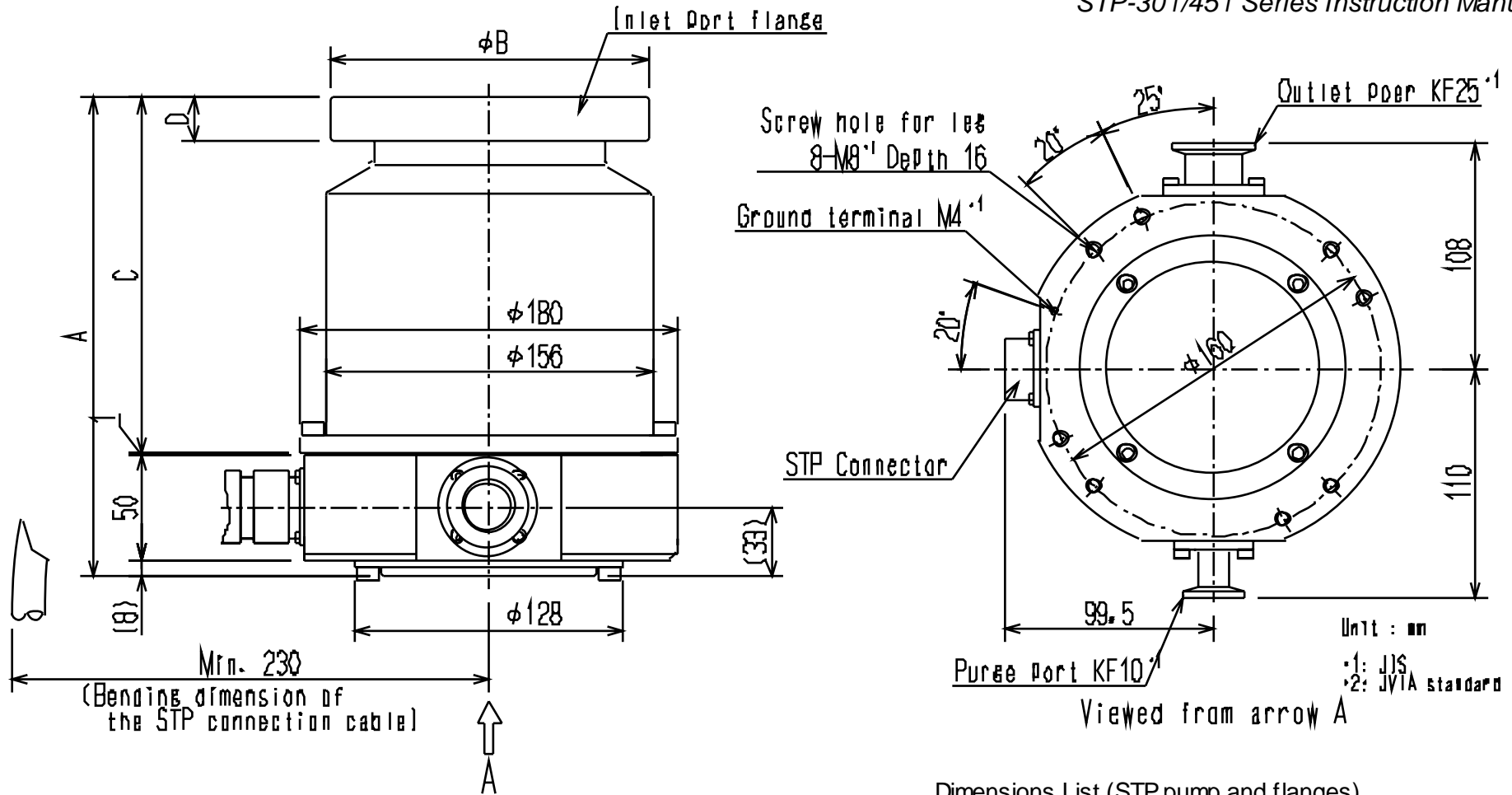

Dimensions List (STP pump and flanges)

Model	STP-301C Series			STP-451C Series		
	ICF ^{*2} 152	VG ^{*1} 100	ISO100	ICF ^{*2} 203	VG ^{*1} 150	ISO160
A	230	230	230	200	200	200
B	152	185	130	203	235	180
C	171	171	171	141	141	141
D	21	12	12	22	12	12

Figure 13.2 External Appearance of the STP Pump [Chemical Specific Type C] (Example: STP-301C)

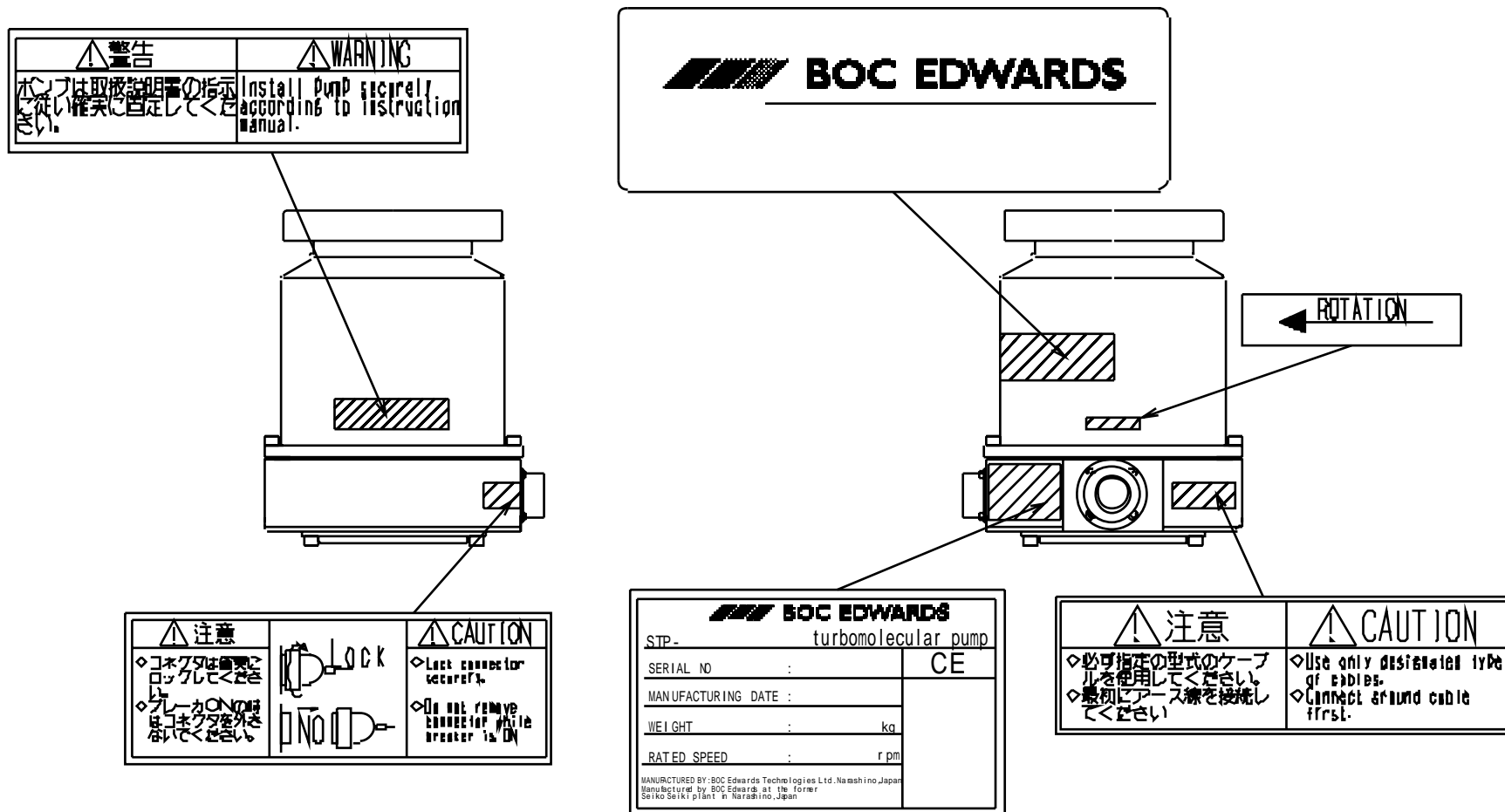

Figure 13.3 Label Affixing Position for the STP Pump

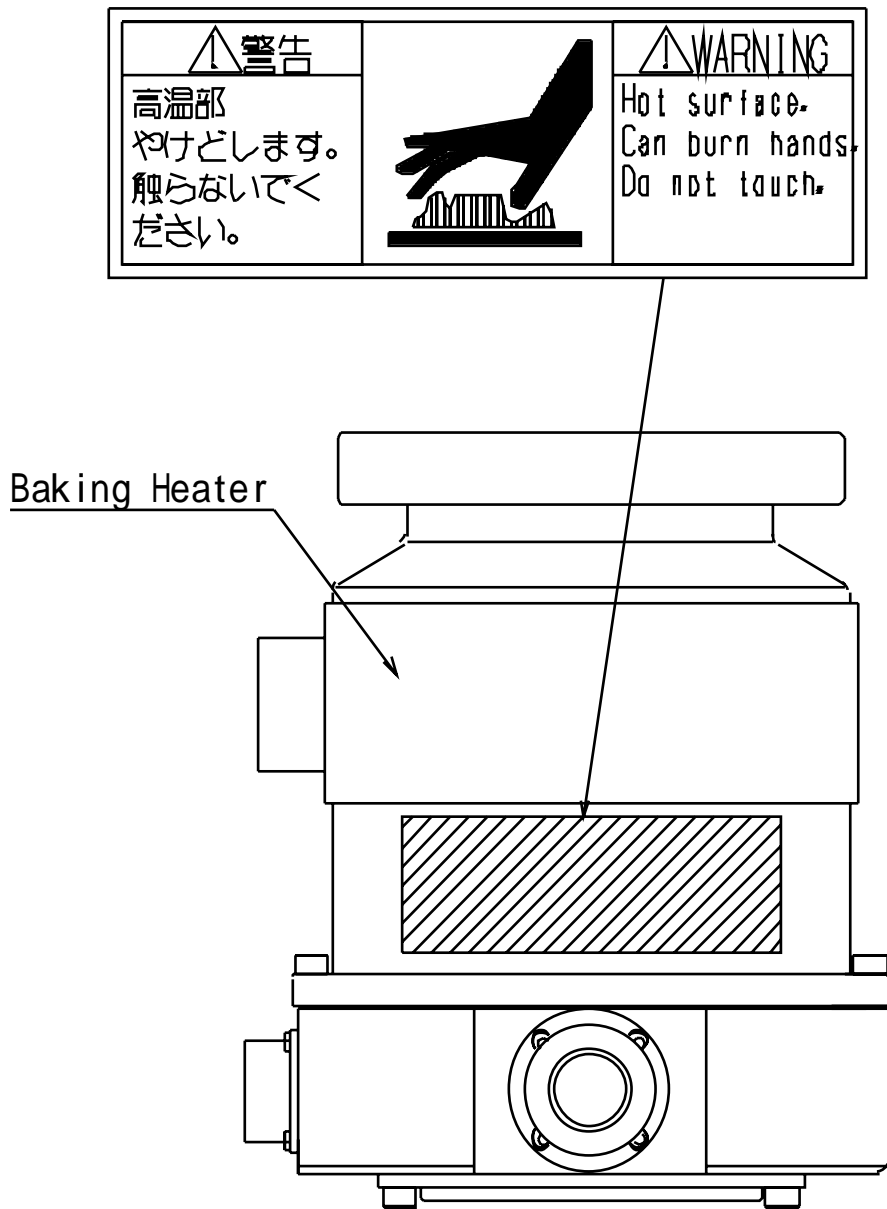

Figure 13.4 Label Affixing Positions for the Optional Accessories

13.2 Specifications of the STP Control Unit

Table 13.2 Specifications of the STP Control Unit

Item		Specifications
Input voltage	VAC	100 to 120+/-10% (100V specification) 200 to 240+/-10% (200V specification)
Input power	At start:	VA 550
	Under rated operation:	VA 150
Input frequency	Hz	50/60 +/-2
Leakage current value	mA	3.5
Input phase		Single phase
Main breaker spec	Rated current	7.5A
	AIC: Ampere Interrupting Capacity	1000A (AC240V, 50/60Hz)
Motor drive system		3-phase DC brush-less motor driver
Output voltage under rated operation (3-phase)	VAC	31 to 62
Output frequency under rated operation	Hz	420 to 800
Ambient temperature range	°C	0 to 40
Storage temperature range	°C	-25 to +55
Mass	kg	7
Dimensions	mm	W209.5 x H132.5 x D315
Operation switches		[Front Panel] <ul style="list-style-type: none"> ● START switch (momentary push button, green) ● STOP switch (momentary push button, red) ● RESET switch (momentary push button, white) ● SELECT switch (momentary push button, white) ● MANUAL/REMOTE changeover switch (slide switch, gray)
Panel indication lamps		<ul style="list-style-type: none"> ● ACCEL. lamp (green LED) ● NORMAL lamp (green LED) ● BRAKE lamp (yellow LED) ● POWER lamp (green LED) ● FAILURE lamp (red LED) ● REMOTE lamp (green LED)
Panel display		● LCD panel (16 characters)

Item	Specifications
Input/output terminals	<ul style="list-style-type: none"> ● AC POWER CON1 (3 pins) ● P.CONNECTOR CON2 (45 pins) ● I/O TB1 (20 pins) ● I/O TB2 (6 pins) ● CON 4 (Optional accessory) (24 pins)
Input/output cables	<ul style="list-style-type: none"> ● Primary power cable ● STP connection cable ● Ground cable
Safety functions	<ul style="list-style-type: none"> ● Magnetic bearing abnormality/error detection (Rotor vibration: 100 μ m0-P or more) ● STP pump overheat detection (Motor: 110 °C or more) ● Driver overload detection (Motor overcurrent) ● Power failure detection (at 25,000 rpm or more: detects power failure of 2 sec. or more) (at less than 25,000 rpm: detects power failure of 0.02 to 0.14 sec.) ● STP pump overspeed detection (51,400 rpm or more) ● STP control unit overheat detection (70 °C or more)

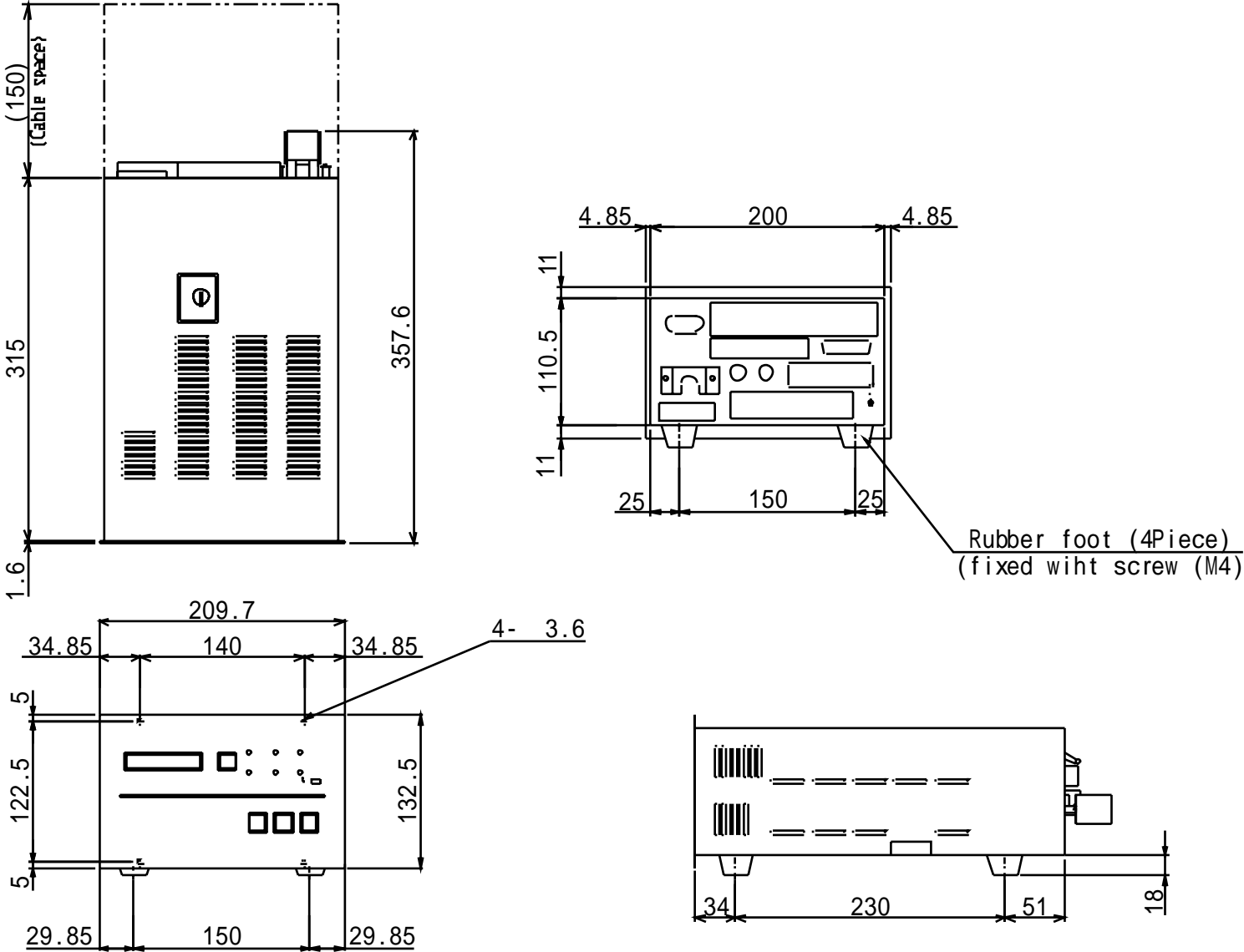

Figure 13.5 External Appearance of the the STP Control Unit

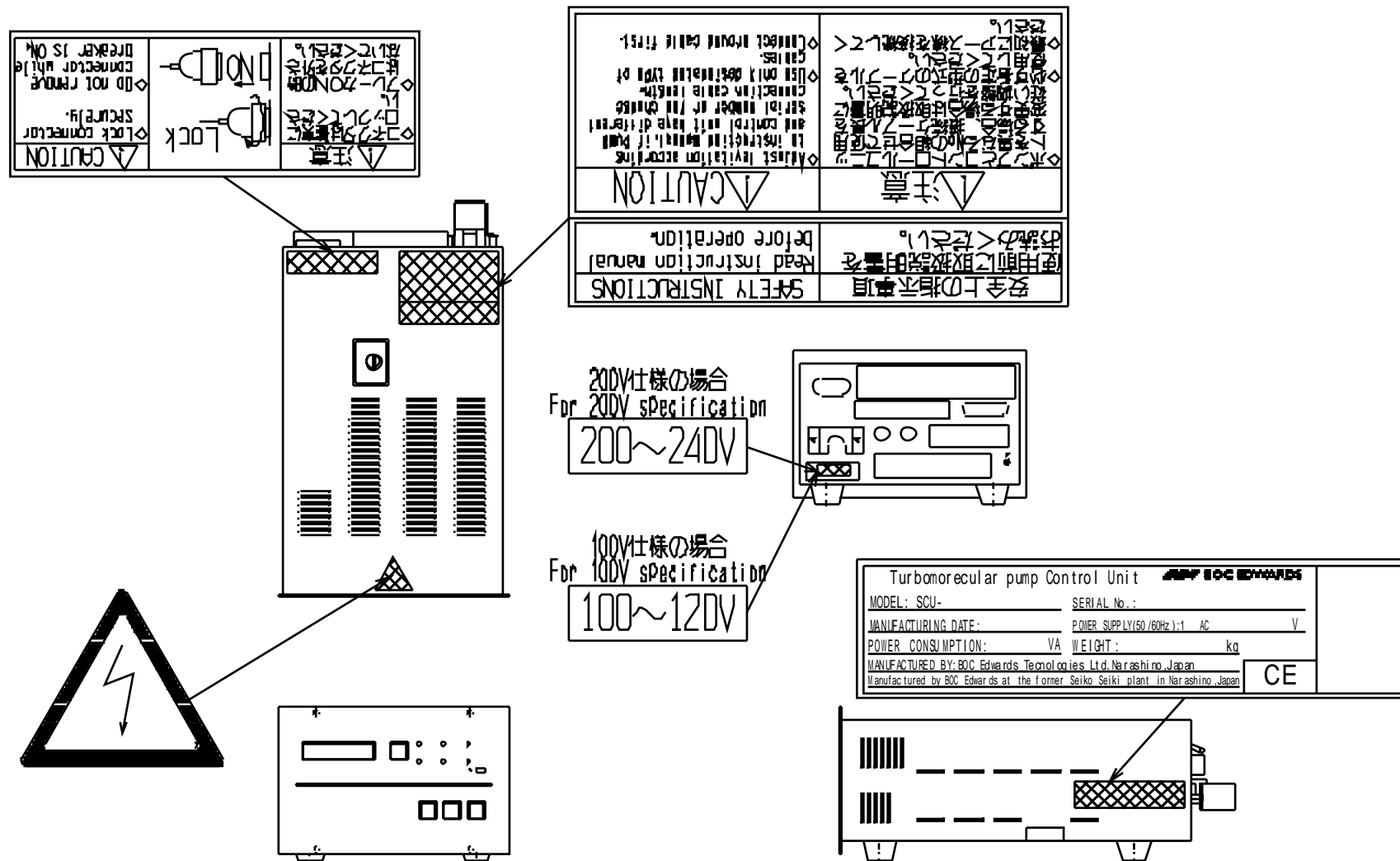

Figure 13.6 Label Affixing Positions for the STP Control Unit

UNIT CONVERSION TABLE

Length

m	cm	mm	inch
1	100	1.00×10^3	39.4
0.01	1	10.0	0.394
1×10^{-3}	0.10	1	39.4×10^{-3}
25.4×10^{-3}	2.54	25.4	1

Weight

g	kg	lb.
1	1.00×10^{-3}	2.20×10^{-3}
1×10^{-3}	1	2.20
454	0.454	1

Pressure

Pa	Torr	kgf/cm ²
1	7.50×10^{-3}	1.02×10^{-5}
133	1	1.36×10^{-3}
9.81×10^4	736	1

For more information, contact to the nearest Service Office.

Manufacture:

BOC Edwards Japan Limited

2-4-1, Shibakoen, Minato-ku, Tokyo 105-0011 JAPAN

Telephone:	Domestic	03-5470-6530
	International	+81-3-5470-6530
Facsimile:	Domestic	03-5470-6521
	International	+81-3-5470-6521