

VIEW OUR INVENTORY

TURBOVAC CARTRIDGE PUMP

TW 220/150 S

TW 400/300/25 S

TW 220/150/15 S

TW 400/300/25 S-PP

Dual & Triple Inlet Wide-range

Incorporation Declaration & Operating Instructions
GA05146_002_A5

Part Nos.

800160V0007

114 30

800160V0015

800160V0017V

800160V0019C

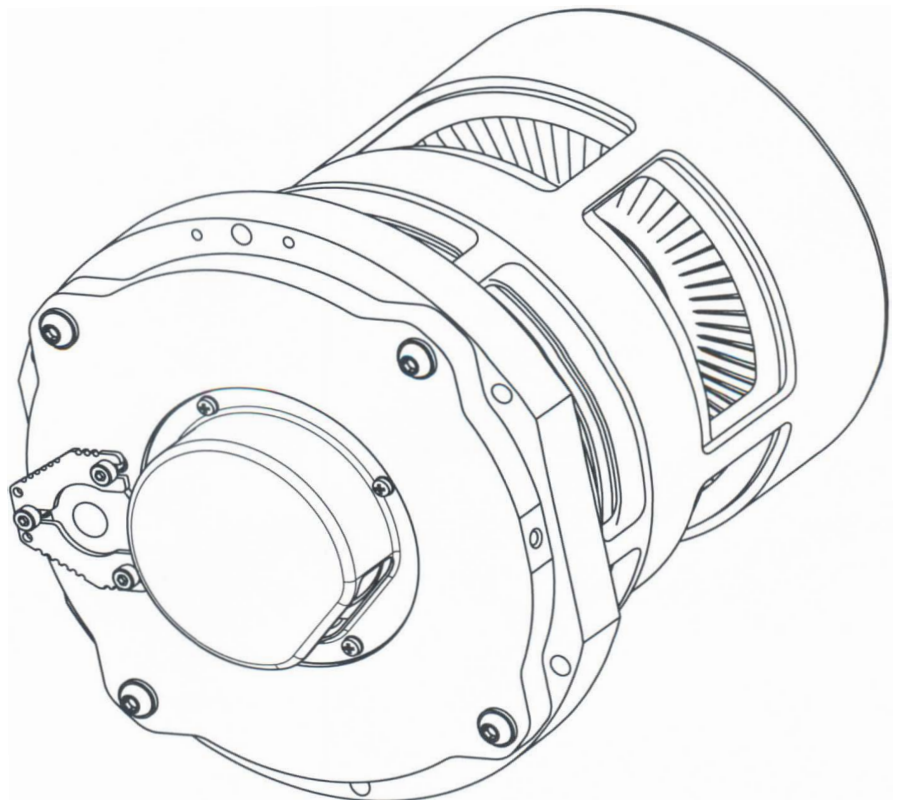

Contents

	Page
0 Important Safety Information	4
0.1 Mechanical hazards	4
0.2 Electrical hazards	5
0.3 Thermal hazards	6
0.4 Hazards caused by materials and substances	6
0.5 Danger of ignition	7
0.6 Dangers in connection with safety-related measures and precautions	7
0.7 Risk of damaging the pump	7
1 Description	8
1.1 Design	8
1.2 Standard equipment	9
1.3 Technical data	10
1.4 Ordering data	10
1.5 Accessories	13
2 Transport and storing	14
3.1 Conforming utilization	15
3.1.1 Non-conforming utilization	15
3.2 Operating environment	16
3.3 Attach the pump to the vacuum chamber	17
3.4 Forevacuum connection	19
3.5 Connect purge gas or a venting valve	20
3.6 Connect the frequency converter	20
4 Operation	22
4.1 Media compatibility / purge gas	22
4.2 Start-up	22
4.3 Switching on	23
4.4 Shutting down	24
4.5 Venting	25
4.6 Removing the pump from the system	26
5 Maintenance	27
5.1 Cleaning	27
5.2 Oerlikon Leybold Vacuum Service	27
6 Troubleshooting	28
7 Waste Disposal	32
Certificates	32
EC Incorporation Declaration	33
EC Declaration of Conformity	34

Safety Information

Obligation to Provide Information

Before installing and commissioning the pump, carefully read these Operating Instructions and follow the information so as to ensure optimum and safe working right from the start.

The Oerlikon Leybold Vacuum **TURBOVAC** has been designed for safe and efficient operation when used properly and in accordance with these Operating Instructions. It is the responsibility of the user to carefully read and strictly observe all safety precautions described in this section and throughout the Operating Instructions. The pump must only be operated in the proper condition and under the conditions described in the Operating Instructions. It must be operated and maintained by trained personnel only. Consult local, state, and national agencies regarding specific requirements and regulations. Address any further safety, operation and/or maintenance questions to our nearest office.

DANGER indicates an imminently hazardous situation which, if not avoided, will result in death or serious injury.

WARNING indicates a potentially hazardous situation which, if not avoided, could result in death or serious injury.

CAUTION indicates a potentially hazardous situation which, if not avoided, could result in minor or moderate injury.

NOTICE is used to notify users of installation, operation, programming or maintenance information that is important, but not hazard related.

We reserve the right to alter the design or any data given in these Operating Instructions. The illustrations are not binding.

Retain the Operating Instructions for further use.

NOTICE



DANGER



WARNING



CAUTION



NOTICE



Original installation and operating instructions.

Safety Information



0 Important Safety Information

0.1 Mechanical hazards

- 1 Avoid exposing any part of the human body to the vacuum.
- 2 The pressure in the pump must not exceed 1.4 bar (absolute).
- 3 The pump is intended for generating a vacuum only. If there is a risk of an overpressure within the system and the pump, then the pump must be protected against this, by way of an overpressure safety valve, for example.
- 4 Vent the pump only up to atmospheric pressure.
- 5 When using the pump with a purge gas valve, protect the purge gas supply such that in the event of a malfunction no overpressure can occur within the system.
- 6 The pump must be firmly mounted to the vacuum chamber. If the mounting is not sturdy enough, pump blockage could cause the pump to break loose; internal pump components could be thrown in all directions. Never operate the pump (in bench testing, for example) without proper flanging to the vacuum chamber. Observe the information in Section 3.3.
- 7 We recommend to change the rotor after 80,000 hours of operation at the latest. Due to high-speed and temperature, the service life of the rotor is limited. If the rotor is changed too late, it may be destroyed. Thus in the flange mounts high forces and torque conditions can occur. The mounting screws for the pump may be torn off. When using clamped flange connections at the housing or with components above the housing, sudden twisting of the entire pump can be experienced.
- 8 Turbopumps as described in the following operation manual contain a high portion of kinetic energy due to their high rotational speed in combination with the specific rotor mass. In case of a malfunction of the system, for example rotor/stator contact or even a rotor crash, the rotational energy is released.
- 9 To avoid the destruction of the equipment and to prevent injuries of the operating staff the leading European manufacturers of vacuum pumps strictly recommend to follow the installation instructions as given in this manual.

0.2 Electrical hazards

- 1 The electrical connection must only be provided by a trained person. Please observe the national regulations in the country of use like EN 50110-1 for Europe, for example.
- 2 The frequency converter must only be connected to power supplies which meet the requirements for functional extra-low voltages with positive isolation in accordance with IEC 60364-4-41 (or local regulations) (PELV).
- 3 Lethal voltages are present at the mains connections. Before starting with any maintenance and service work, de-energise (lockout/tagout) the product first.
- 4 Unplug any connectors only when the mains voltage is switched off and the pump does no longer turn.
- 5 Unauthorized device conversion and modifications are prohibited for safety reasons.
- 6 Hazardous voltages are present within the frequency converter. When coming into contact with these, death or severe injury can result. After the pump has arrived at standstill, disconnect the frequency converter from the mains power and prevent it against being switched on inadvertently (lockout/tagout) before opening it. Basically there is no reason why the frequency converter should be opened. There are no user serviceable parts inside.
- 7 When the connector cable is attached, the outputs at the frequency converter are not free of voltage.
- 8 Lay connecting lines so that they cannot be damaged. Protect the lines against humidity and contact with water. Avoid any heat stress on the line due to unfavourable laying conditions.
- 9 Suitably support the connecting lines so that the pumps are not exposed to any major mechanical stress.
- 10 Do not expose pump, frequency converter and the connections to dripping water. Note the information on the IP type of protection.
- 11 When storing pump, frequency converter and connecting lines in a humid atmosphere, these can suffer corrosion. Corrosion gives rise to conductive deposits which in turn can cause short-circuits and reduce the insulation levels of electrical components
- 12 Transport pump, frequency converter and connecting cables only in their original packaging so as to avoid any mechanical damage which in turn may reduce air gaps and creepage distances.
- 13 When applying external voltages above 42 V to the connection terminals, observe the applicable VDE safety regulations!
- 14 Make the electrical connections only after pump and accessories (e.g. air cooler) have been installed mechanically.

DANGER



Safety Information

CAUTION



0.3 Thermal hazards

- 1 Handle the equipment only while vented and cooled down.
- 2 During operation of the pump certain areas can get so hot (80 °C max.) so that there is the risk of suffering burns. Protect hot parts against being touched.
- 3 Note the warning information on the housing surface. If these warning notices have been removed, covered or obstructed, include corresponding additional warning notices.

DANGER



0.4 Hazards caused by materials and substances

- 1 The pump is not suited for pumping of reactive or corrosive media. If the rotor is attacked by process gases, it can suffer destruction. Thus in the flange mounts high forces and torque conditions can occur. The mounting screws for the pump may be torn off. When using clamped flange connections at the housing or with components above the housing, sudden twisting of the entire pump can be experienced.
- 2 If low concentration corrosive or reactive gases are being pumped, then operate the pump with purge gas.
- 3 Please consult us as to which types of pump are required for specific processes and applications.
- 4 The forevacuum line must be tight. Hazardous gases can escape at leaks or the gases being pumped can react with air or humidity. A leak search will always be required after having installed the pump and after service work on the vacuum. Upon delivery the pump has an integral leak rate of $< 5 \cdot 10^{-7}$ mbar-l/s. When pumping toxic gases we recommend a leak search on a regular basis.
- 5 If the pump has previously handled hazardous gases, implement the proper precautionary measures before opening the intake or exhaust connection. Before opening the pump, purge it for a longer period of time with an inert gas. If necessary, use gloves, a respirator and/or protective clothing and work under an exhaust hood. Firmly seal off the pump. When shipping the contaminated pump for servicing, please also state the type of hazard. For this you must use a form which we have prepared for you.
- 6 Contaminated parts can be detrimental to health and environment. Before beginning with any work, first find out whether any parts are contaminated. Adhere to the relevant regulations and take the necessary precautions when handling contaminated parts.

0.5 Danger of ignition

- 1 During operation the pressure inside the turbomolecular pump is so low that there is no danger of ignition (at pressures below about 100 mbar). A hazardous condition will be created if flammable mixtures enter the hot pump at pressures above 100 mbar. During operation the pump can reach temperatures as high as 120°C internally, and at parts of the outside surfaces 80 °C. Sparks could occur in case of damage to the pump and these could ignite explosive mixtures. Also note the safety information provided by the gas supplier.

CAUTION



0.6 Dangers in connection with safety-related measures and precautions

- 1 The frequency converter is not equipped with its own emergency shut down switch. Such a facility needs to be provided from the side of the system.

CAUTION



0.7 Risk of damaging the pump

- 1 Never touch the rotor. Touching the rotor may cause injury and damage the rotor bearing.
- 2 Foreign objects which enter the pump through the intake would cause serious damage to the rotor. That's why we recommend installing an inlet screen. Damages caused during operation without the inlet screen are excluded from warranty.
- 3 Ensure correct polarity when connecting the TURBO.DRIVE. A wrong polarity may cause an internal fuse to blow. The fuse can only be changed by Oerlikon Leybold Vacuum Service.
- 4 The interface connectors have UNC 4-40 threads. Do not use connectors with M3 threads.
- 5 Disconnect and connect the cable connections only while the pump is turning no longer (green status LED off) **and** with the mains power switched off (yellow power LED off). Otherwise there is the risk of damaging the frequency converter.
- 6 Exposure of the pump to accelerating forces must be avoided or reduced to such an extent that the rotor unit will not be excited by vibrations. In the case of critical applications you must consult our Applications Dept. first.

NOTICE



Description

1 Description

The TURBOVAC CARTRIDGE TW 220/150 S is a dual-inlet and the TW 220/150/15 S and the TW 400/300/25 S (-PP) are triple-inlet wide-range turbomolecular pumps designed for mass spectrometers to evacuate up to three vacuum chambers.

They have no housing and are designed to be integrated into a system.

They are suitable for pumping air and clean gases.

Required for the operation are

- the TURBO.DRIVE 400 frequency converter
- a power supply for the TURBO.DRIVE and
- a forevacuum pump

1.1 Design

The pump comprises essentially a multi-stage rotor with the stator group, and the drive.

The first section of the rotor are two turbomolecular pump stages while the second section represents a Holweck stage. The Holweck pumping stage increases the permissible forevacuum pressure level markedly when compared with the classical turbomolecular pump.

The pumps have gas inlets into the turbo stages, the triple-inlet pumps have a third gas inlet into the Holweck stage. The two triple-inlet pumps are very similar, they differ mainly in the Holweck stage and the operating speed.

Bearings The rotor shaft runs in two lifetime lubricated ceramic ball bearings.

Motor The pump is driven by a split-cage DC motor. In this motor the rotor and stator windings are separated by a vacuum-tight can. Consequently the rotor runs inside the vacuum while the stator is outside the vacuum. This eliminates any need of vacuum feedthroughs.

A circuit board is installed in the pump. It is equipped with a temperature sensor and a code resistor for identification of the pump type.

Cooling Standard pumps rely on convection cooling, but require additional air or water cooling depending on the load, like increased gas throughput, high ambient temperatures or operation in a closed housing.

Forevacuum and purge/vent connection The pumps have DN 16 KF connectors for forevacuum. Additionally, the TW 400/300/25 S-PP has a purge gas and venting connection.

Frequency converter The pump is driven by an electronic frequency converter TURBO.DRIVE 400. All functions like, for example, speed control, pump sensing or temperature monitoring are monitored by the TURBO.DRIVE 400. This unit is powered by an external power supply.

1.2 Standard equipment

The pumps are shipped sealed in a PE bag with a desiccant to absorb moisture. The maximum useful life of the desiccant is one year.

Dual Inlet, Part No. 800160V0007

- 6 screws M6 x 25 ISO 4762, Part No. 201 03 105
- 6 washers Ø 6.4, Part No. 200 15 040
- 1 O-ring 132 x 5, Part No. 701 120 296
- 1 O-ring 150 x 3, Part No. 239 70 418
- 1 Centering ring DN 16 KF
- 1 FPM sealing ring
- 1 Clamping yoke

Triple Inlet, Part Nos. 114 30, 800160V0015, 800160V0017V, 800160V0019C

- 6 screws M6 x 30 ISO 4762, Part No. 201 03 259
- 6 washers Ø 6.4, Part No. 200 15 040
- 1 O-ring 132 x 5, Part No. 701 120 296
- 2 O-ring 150 x 3, Part No. 239 70 418
- 1 Centering ring DN 16 KF
- 1 FPM sealing ring
- 1 Clamping yoke
- 1 Fitting for purge gas connection, Part. No. 6512686
(only 800160V0017V)

PE = Polyethylene

FPM = Fluororubber, resistant to temperatures up to 150°C (302 °F)

Description

1.3 Technical data

TURBOVAC		TW 220/150 S	TW 220/150/15 S	TW 400/300/25 S
High-vacuum connections		depends on customized housing variants		
Max. pumping speed for N ₂				
HV port	l·s ⁻¹	320	320	400
Interstage port I	l·s ⁻¹	250 – 300	250 – 300	300
Interstage port II	l·s ⁻¹	—	15	25
Operating pressure				
HV port	mbar		10 ⁻⁵ - 10 ⁻⁷	
Interstage port I	mbar		10 ⁻² - 10 ⁻⁴	
Interstage port II	mbar	—	10 ⁻¹	10 ⁻¹
Max. permissible forevacuum pressure	mbar		8	
Recommended frequency converter		TURBO.DRIVE 400		
Operating speed	r.p.m.	45,000	45,000	48,000
Run-up time, approx.	min	8	8	10
Forevacuum connection	DN		16 KF	
Weight, approx.	kg		12	
Type of protection	IP		20	
Only for TW 400/300/25 S-PP				
Purge/vent connection		—	—	M5 (similar UNF 10-32)
Enclosed fitting for tube with outer diameter x wall thickness	mm			4.3 x 1
Max. purge gas flow	mbar·l·s ⁻¹	—	—	0.4
Ambient temperature during operation			+ 15 - + 40 °C	
storage			- 15 - + 70 °C	
Max. rel. air humidity			approx. 95% ¹⁾ (non-condensing)	

1) More details in Applied technical standard IEC 721-3-3
3K3/3Z1/3B1/3C1/3S2/3M1

1.4 Ordering data

TURBOVAC CARTRIDGE	Part number	used as spare part for
TW 220/150 S	800160V0007	—
TW 220/150/15 S	114 30	800160V0009
TW 220/150/15 S	800160V0015	800160V0012
TW 400/300/25 S-PP (with purge port)	800160V0017V	—
TW 400/300/25 S (short stand)	800160V0019C	800160V0019

Description

TW 220/150 S
 Part No. 800160V0007

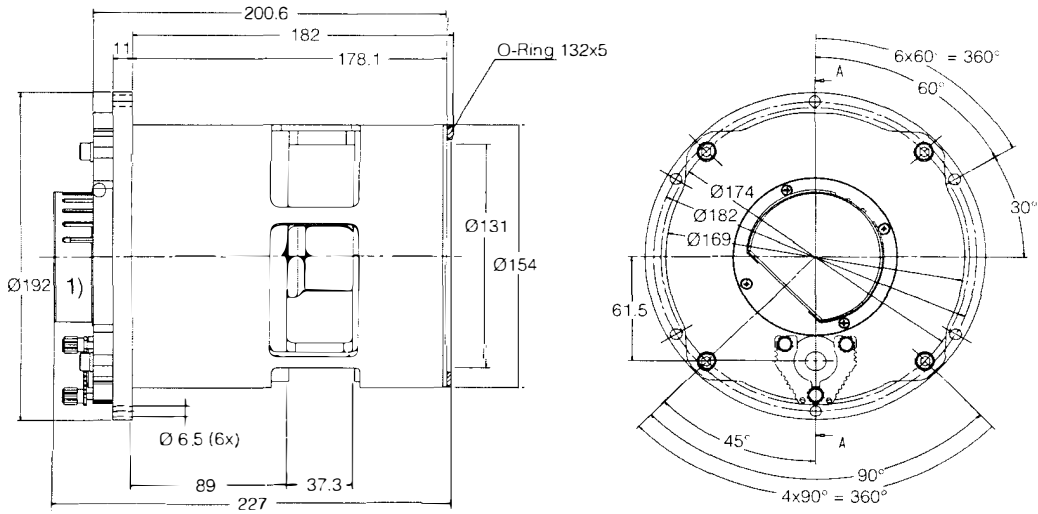

TW 200/150/15 S
 Part No. 800160V0015
 TW 400/300/25 S
 Part No. 800160V0019C
 TW 400/300/25 S-PP
 Part No. 800160V0017V

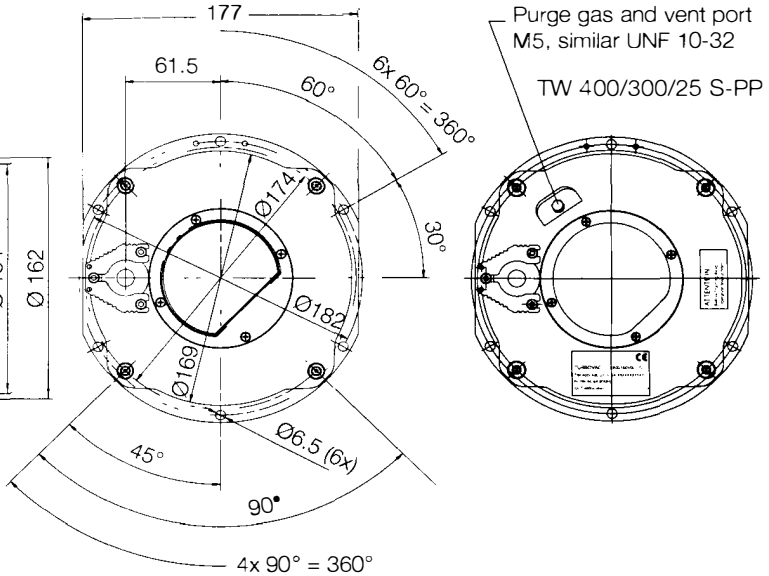

1) Position of electrical connection depends on type and part no.

Fig. 1.1 Dimensional drawings , dimensions in mm

Description

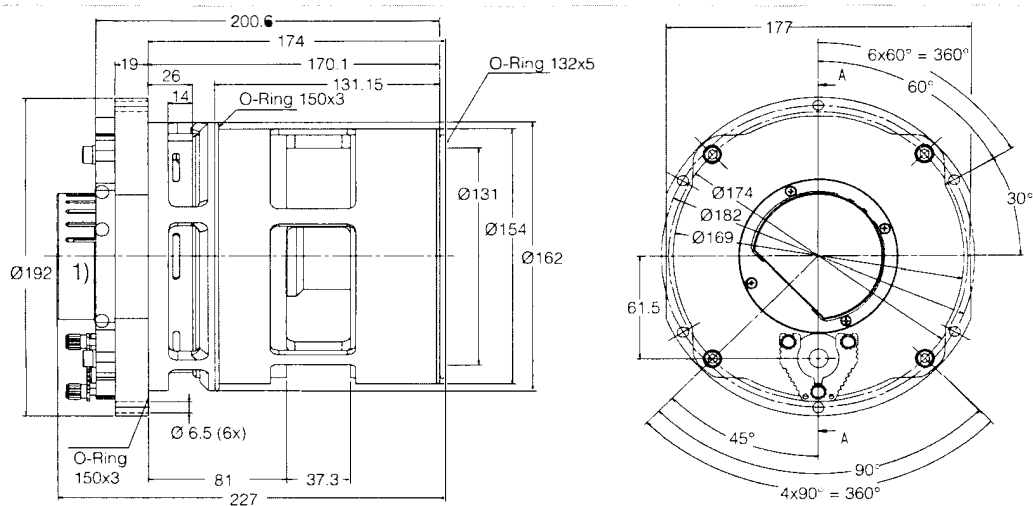

TW 220/150/15 S
Part No. 114 30



1) Position of electrical connection depends on type and part no.

Fig. 1.2 Dimensional drawings , dimensions in mm

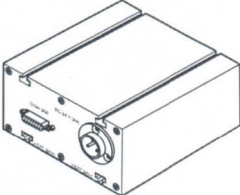
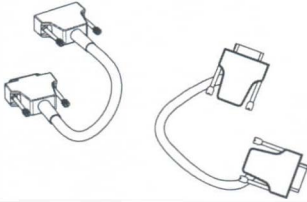
1.5 Accessories

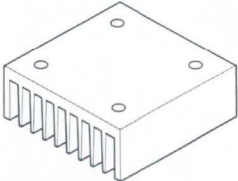
	Part number	
Frequency converter		
TURBO.DRIVE 400		
with RS 232 C interface	800073V0002	
with RS 485 C interface	800073V0003	
with Profibus interface	800073V0004	
Connecting cable pump - frequency converter		
0.2 m long	800152V0021	
0.3 m long	800152V0023	
0.4 m long	800152V0022	
1.0 m long	152 47	
2.5 m long	864 49	
3.0 m long	864 40	
5.0 m long	864 50	
Power Supply		
Astec 24 V/250 W with air cooler	864 46	
OEM power supply (with screw terminals)		
SITOP 24 V / 10 A	152 50	
24 V DC cable (TURBO.DRIVE 400 – OEM power supply)		
3 m	200 12 732	
5 m	200 12 733	
10 m	200 12 734	
20 m	200 12 735	
Mains cable for power supply, 2 m long		
with EURO plug	800102V0001	
with US plug 5-15P	800102V1001	
Options		
Heat sink for frequency converter	800110V0001	
Purge gas valve 24 V DC 0.4 mbar-l/sec	800152V0003	

Transport and storing

2 Transport and storing

Remove the equipment from the transportation box and keep the packaging. Make sure that the product has not been damaged during transportation. If this unit is damaged contact your carrier and inform Oerlikon Leybold Vacuum if necessary. For storage of the product, use the packaging provided.

NOTICE



Be careful not to damage the sockets and connections during transportation.

WARNING



Do not stand below the pump while connecting or removing the turbomolecular pump.

The turbomolecular pump is shipped in a sealed PE bag with desiccant. Do not open the sealed package until immediately before installing.

Do not remove the covers and blanking flanges until you are ready to make the connections, to ensure that the turbomolecular pump is installed under the cleanest possible conditions.

Turbomolecular pumps which were not operated for a period of over 12 months should be returned to us. For more information on this please contact your local sales partner.

Do not store pump and accessories in a moist atmosphere so as to prevent these items from suffering corrosion.

3 Installation

3.1 Conforming utilization

The turbomolecular pump is intended for generating a vacuum. It is suited for non-corrosive processes only.

The turbomolecular pump must be bolted to a rigid vacuum system and connected to a suitable backing pump.

The turbomolecular pump must only be operated with correspondingly specified frequency converters, the special connecting cables and mounting bolts.

Both pump and frequency converter are intended for being operated within closed rooms.

The use of any accessories which have not been specified by Oerlikon Leybold Vacuum is only allowed after approval by Oerlikon Leybold Vacuum.

3.1.1 Non-conforming utilization

Non-conforming utilizations for both pump and frequency converter are among others:

- Pumping of gases and vapours for which the materials of the pump are unsuitable.
- Operation in connection with processes in which GaAs (gallium arsenide) is being pumped.
- Pumping of gas mixtures with an oxygen content of > 21%.
- Pumping of corrosive gases and dust containing gases without reverting to purge gas operation.
- Pumping of condensable vapours without suitably controlling the temperature of the pump. Upon compression within the pump, these vapours may condense or form deposits.
- Pumping of dusts and solids without the use of suitable screens and filters.
- Operation at an inadmissibly high forevacuum pressure.
- Operation at inadmissibly high gas loads.
- Utilization of both pump and frequency converter in explosion hazard areas.
- Non-compliance of the specified maintenance and servicing intervals for both pump and frequency converter.
- Operation of the pump and drive electronics in environments which demand protection type IP 20 or higher and where the installation site is over 1000 m the above sea level.
- Utilization in systems and pump systems in which the pressure may exceed 1.4 bar abs.
- Operation with an inadequately mounted pump.

Installation

- Operation without having flanged the pump to the system or without having connected it to a suitable backing pump.
- Operation with additional heat sources involving thermal radiation, thermal conduction via the high vacuum or the forevacuum flange, strong magnetic fields or very hot process gases, for example.
- Use in systems in which impact stress and vibrations or periodically occurring forces affect pump, frequency converter and cables.
- Operation on moving system or system components (locks or movable pump systems, for example).
- Operation at vibration absorbers and vacuum components (gate valves, valves) which are not capable of sustaining the specified deceleration torque should the pump rotor seize.
- Stepping on pump, add-on parts, drive electronics, flanges and cables to climb onto the system.
- Fitting of add-on parts to the forevacuum flange which cause an inadmissible high load.
- Removing, covering or obstructing warning notices.
- Standstill or storing of pump and drive electronics without suitable sealing-off and drying. Storing in a humid atmosphere can cause corrosion.
- Conversions, manipulations and maintenance work by personnel not authorised by Oerlikon Leybold Vacuum.

WARNING



Any non-conforming utilisation of pump, frequency converter and accessories can result in severe injury and cause damage to components.

Ambient temperature

3.2 Operating environment

The maximum permissible ambient temperature is 45 °C (113 °F). Do not expose the pump or the frequency converter to dripping or spraying water.

Magnetic field

If the pump is used within a magnetic field, the magnetic induction at the surface of the pump housing may not exceed:

B = 5 mT if impinging radially and

B = 15 mT if impinging axially.

Install shielding equipment as appropriate if these values are exceeded.

Radiation

The standard pump version without frequency converter is resistant to radiation up to 10³ Gy.

Places of installation

Places of installation up to 1000 m above sea level (3300 ft) are possible without restrictions. At altitudes over 1000 m heat dissipation by the ambient air is impaired. Please consult us.

The frequency converter must not be operated in explosive gas atmospheres.

1 mT (milliTesla) = 10 G (Gauß)

1 Gy (Gray) = 100 rad

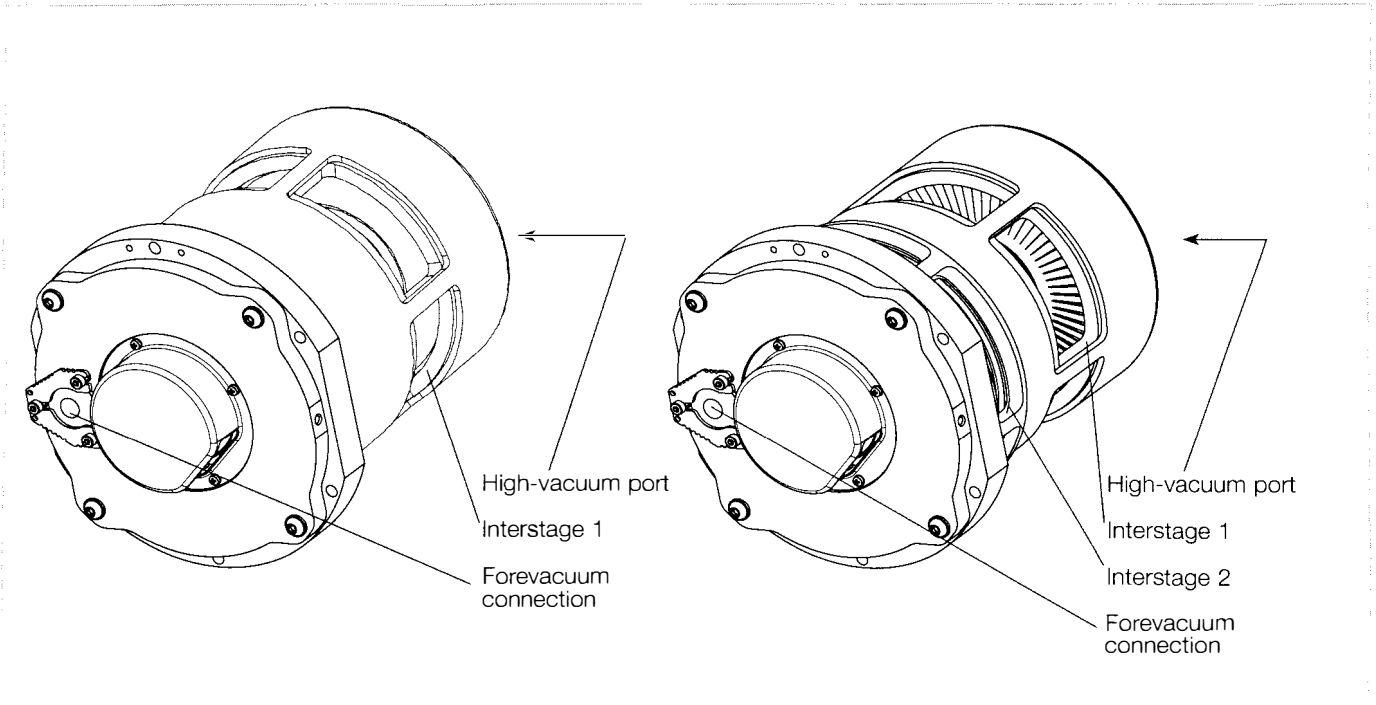

Fig. 3.1 TW 220/150 S and TW 220/150/15 S (TW 400/300/25 S and TW 220/150/15 S similar)

3.3 Attach the pump to the vacuum chamber

Never touch the rotor. Touching the rotor may cause injury and damage the rotor bearing.

The high-vacuum flange must be solidly mounted to the vacuum chamber. Observe Safety Information 0.1.6.

Remove the transport seal from the intake flange and remove the desiccant. Pay attention to maximum cleanliness when connecting.

If the pump should suddenly seize, an ensuing deceleration torque of up to 3200 Nm will have to be absorbed by the system.

For this purpose there are mounting points at the high-vacuum flange.

The flange or housing material to which the pump is bolted, must have at operating temperature a minimum yield strength of 150 N/mm².

NOTICE



WARNING



Torque when the rotor seizes

Installation

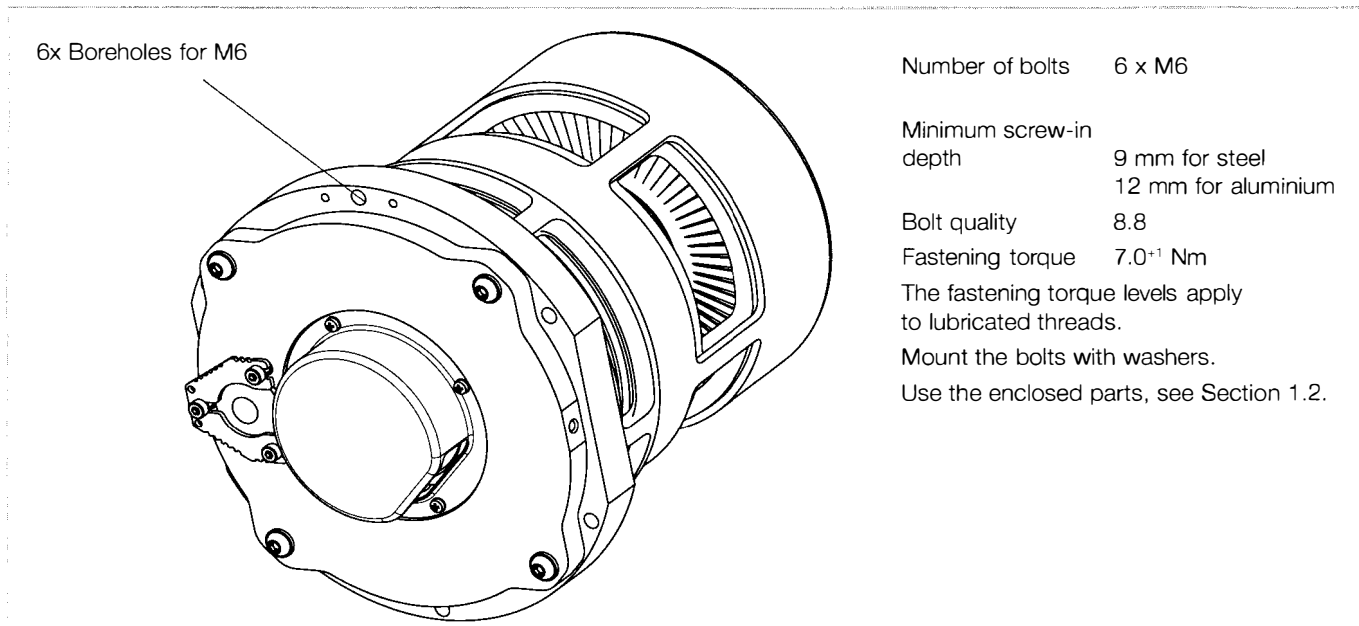

Fig. 3.2 Mounting the pump

Earthquake protection

The standard mounting arrangement for the pump is adequate to ensure earthquake protection. If required mount the system to the floor or the walls.

CAUTION



During operation the pump can get so hot that there is the risk of suffering burns (up to approximately 80 °C). Protect the hot parts against being touched.

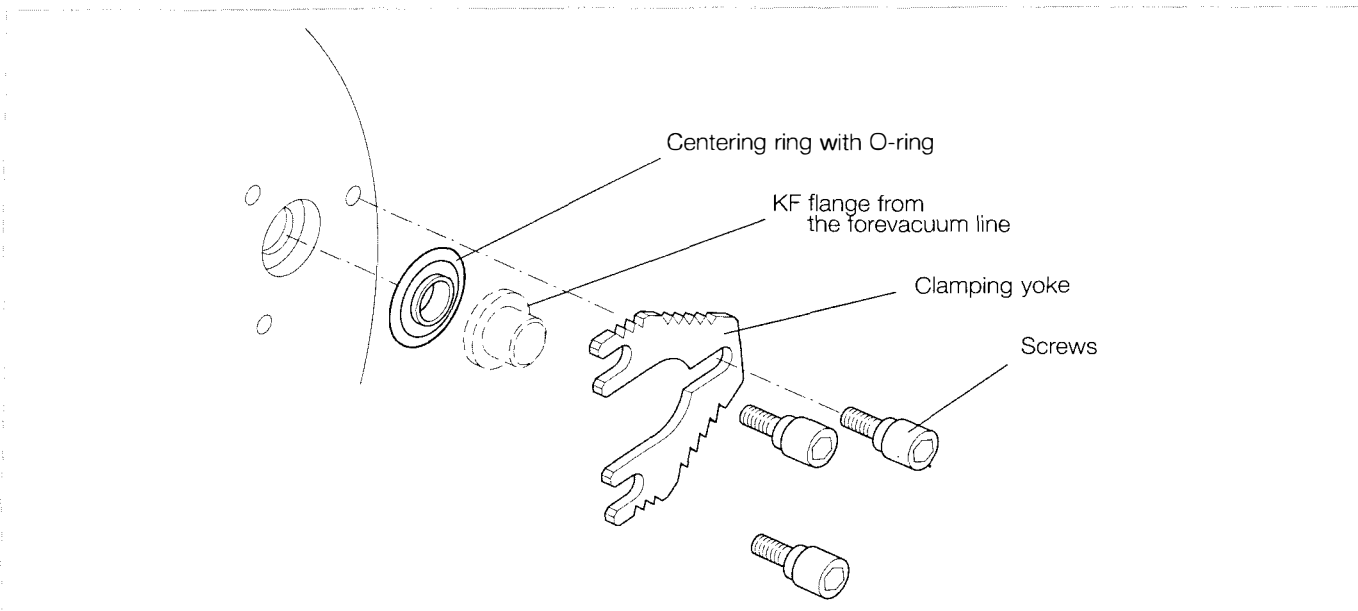

Fig. 3.3 Connecting the forevacuum line

3.4 Forevacuum connection

The high vacuum pressure level which can be achieved is a function of the volume of gas flow Q to be pumped and the forevacuum pressure.

Connect the clean forevacuum line. The connection must be clean and undamaged. The cross section of this line must be so wide that safe operation of the pump can be ensured.

The forevacuum line must be tight. Hazardous gases can escape at leaks or the gases being pumped can react with air or humidity. Observe Safety Information 0.4.4.

DANGER



Fig. 3.5 is a schematic diagram of a pump system incorporating a turbomolecular pump and a TRIVAC forevacuum pump with an anti-suckback valve.

A separate safety valve must be provided for oil-sealed forevacuum pumps without an anti-suckback valve. The safety valve prevents oil flowing back from the forevacuum pump into the turbomolecular pump when the system is not running.

Safety valve

To ensure that the forevacuum space at the turbomolecular pump is kept largely free of oil vapors during operation, as well, we recommend installing an adsorption trap in the forevacuum line. Alternatively purge the forevacuum line with inert gas. In this case the pressure in the forevacuum line must be over 10^{-2} mbar.

Adsorption trap

Provide a roughing line to achieve the shortest cycle times.

Ensure that the pump is sufficiently isolated against vibrations generated by the forevacuum pump.

No forces from the piping system may be allowed to affect the turbomolecular pump. Support the piping correspondingly or decouple through flexible joints.

Installation

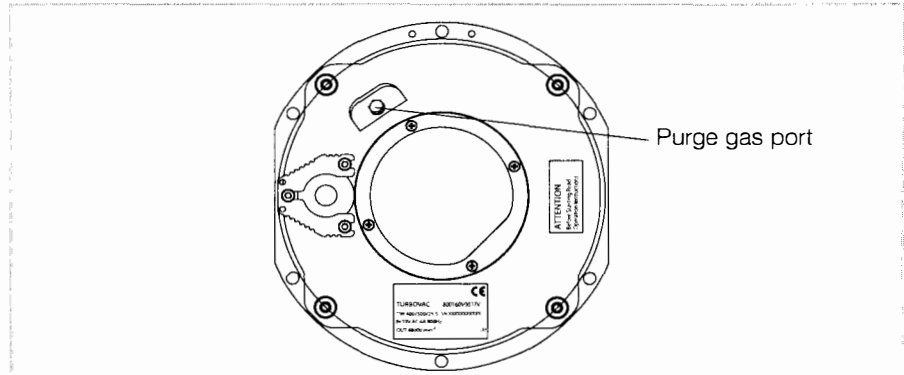

Fig. 3.4 Purge gas port on TW 400/300/25 S-PP

3.5 Connect purge gas or a venting valve

The TW 400/300/25 S-PP has a coupling for a tube as purge gas connection. A purge gas and venting valve or a power failure venting valve or a venting valve may be either connected.

The power failure venting valve or venting valve vents the pump and the forevacuum line when the pump is switched off and thus keeps oil vapor from diffusing back from the forevacuum line.

A choke nozzle in the vent port ensures that the pump is not vented too fast.

When having to decide which gases need or not need to be pumped with purge gas we are available to provide assistance.

Refer to Section 4.1 for suited gases.

When operating the pump with purge gas, the pump needs to be vented via the purge gas valve after having shut down the pump, see Section 4.5.

Consider the additional purge gas flow when selecting a suitable backing pump.

We recommend a purge gas flow of 0.4 mbar·l/s (24 sccm) with Nitrogen.

WARNING



The pressure in the pump must not exceed 1400 mbar (0.4 bar overpressure). Observe Safety Informations 0.1.2 to 0.1.5.

3.6 Connect the frequency converter

Refer to the Operating Instructions for the TURBO. DRIVE 400 and, if required, for the serial interfaces.

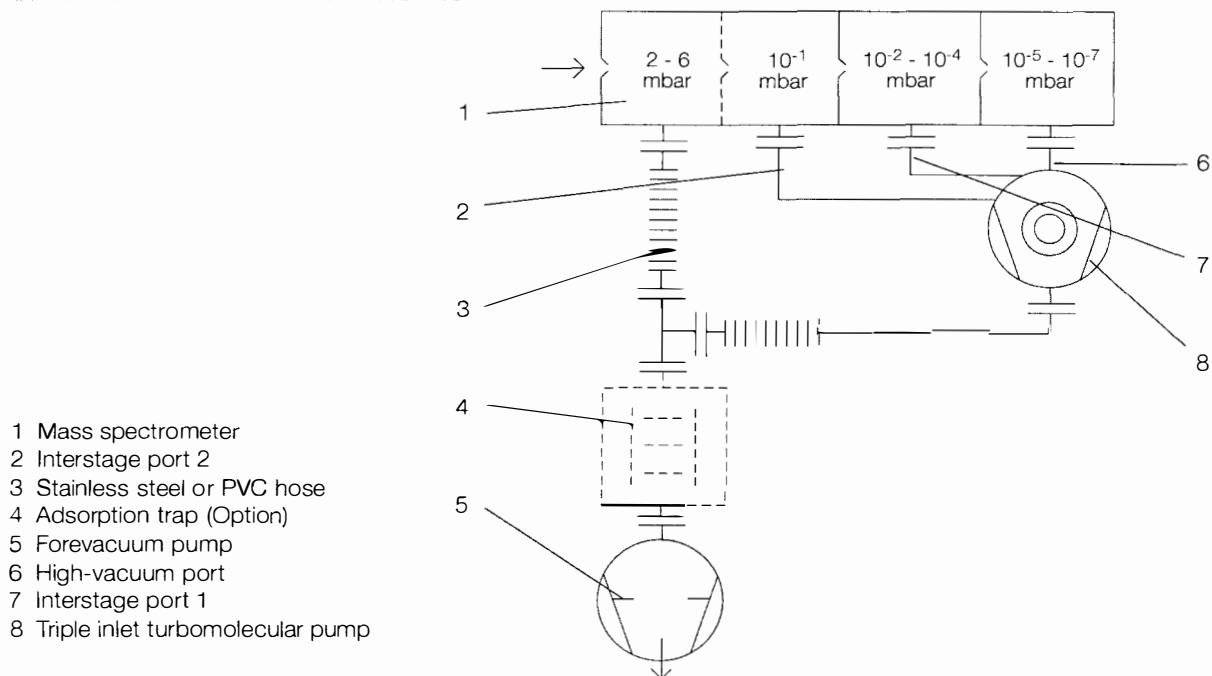

Fig. 3.5 Schematic of a triple inlet turbomolecular pump system

4 Operation

4.1 Media compatibility / purge gas

The TURBOVAC is suitable for pumping air and clean gases.

We would be glad to consult with you as regards the media which can safely be handled with this unit.

Suited for venting are all gases,

- which will not cause corrosion or pitting in aluminium and steel and
- which in connection with process deposits in the pump will not cause corrosion or sticking.

For venting and as the purge gas we recommend inert gases like nitrogen or argon. The temperature of these gases should be between 5 °C and 80 °C, max. relative humidity should not exceed 10 ppm.

The gas must be clean.

In individual cases and after consultation also dry, filtered, oil-free air or filtered ambient air may be used (filter mesh < 1µm).

Change the filters after some time, at least annually.

4.2 Start-up

The TURBO.DRIVE 400 offers the possibility of gently running in pumps which were not operated for a period between 6 and 12 months. Before starting, set up parameter 119 correspondingly.

Turbomolecular pumps which were not operated for a period of over 12 months should be returned to us. For more information on this please contact your local sales partner.

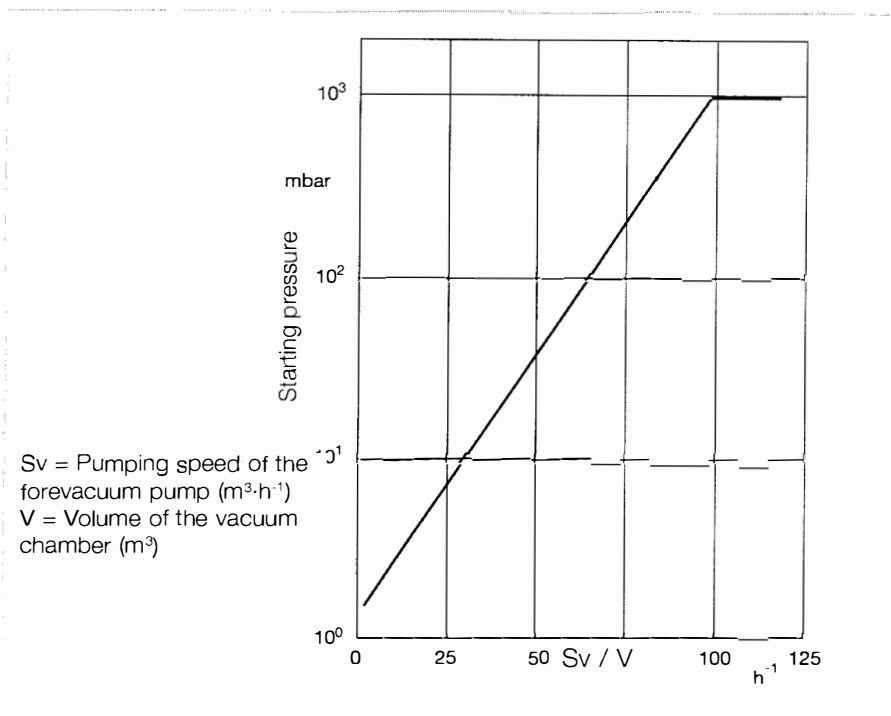

Fig. 4.1 Determining the starting pressure of a turbomolecular pump when evacuating large volumes

4.3 Switching on

Switch on the 24 V DC power supply. The yellow LED at the frequency converter lights up.

The maximum starting pressure for the turbomolecular pump can be read from the graph in Fig. 4.1.

Switch on the turbomolecular pump at the frequency converter

- via pins 7 and 8 of the socket REMOTE (X1) (For example via a remote control or with the aid of the plug with integrated ON/OFF switch.
- by a start command via the interface.
- For the power supply units offered or recommended by Oerlikon Leybold Vacuum: If the contacts 7 and 8 at the REMOTE (X1) connector are closed the pump starts automatically when the DC voltage is switched on (provided parameter 12 is set to 0).

The turbomolecular pump accelerates. The green LED flashes. When the pump reaches normal operation the green LED lights up permanently.

Avoid the influences of shock and vibration when the pump is running.

Exposure of the pump to accelerating forces must be avoided or reduced to such an extent that the rotor unit will not be excited by vibrations. In the case of critical applications you must consult our Applications Dept. first.

After a mains power failure the pump can run up automatically once more.

Starting pressure

NOTICE



Operation

4.4 Shutting down

Switch off the pump at the frequency converter.

- via contacts 7 and 8 of the socket REMOTE (X1), if parameter 12 = 0.
- apply a stop command via the interface, if parameter 12 = 1 or 2.
- for the power supply units offered or recommended by Oerlikon Leybold Vacuum switch off the DC voltage.

Generator operation

After switching off, the green status LED will flash until the rotor of the turbomolecular pump is at standstill. This may take several minutes. With the DC power supply off, the turbomolecular pump will act as a generator supplying the frequency converter with energy as indicated by the yellow power LED.

Switch off the forevacuum pump.

Venting

When using oil-sealed forevacuum pumps, vent the turbomolecular pump before it comes to a stop; refer to Section 4.5.

When using TRIVAC pumps the built-in anti-suckback valve will close automatically, shutting off the forevacuum line. In forevacuum pumps without a vacuum retention valve, close the valve in the forevacuum line.

When the system is not operating, ensure that neither ambient air nor cleaning media can enter the pump.

If a failure occurs the turbomolecular pump will be shut down automatically. The red LED at the frequency converter lights up.

Emergency shut down

In the case of an emergency shut down, the pump is switched off as described above. The rotor of the turbomolecular pump may be stopped faster by venting the pump.

Under vacuum conditions the pump may take up to one hour to run down, when venting to atmospheric pressure it may take up to one minute. During the time the pump is running down, the green LED at the frequency converter will flash, indicating that the rotor has not yet arrived at standstill.

When shutting down by switching off the power supply voltage, there will be only enough power for the LEDs down to a speed of the pump of approximately 200 Hz. Thus the pump may still turn without a LED being on. For this reason, when switching off without venting, wait for approximately 15 minutes after the LEDs have turned off until the pump has arrived at standstill.

CAUTION



Unplug any connectors only when the mains voltage is switched off **and** the pump does no longer turn (the green LED is off).

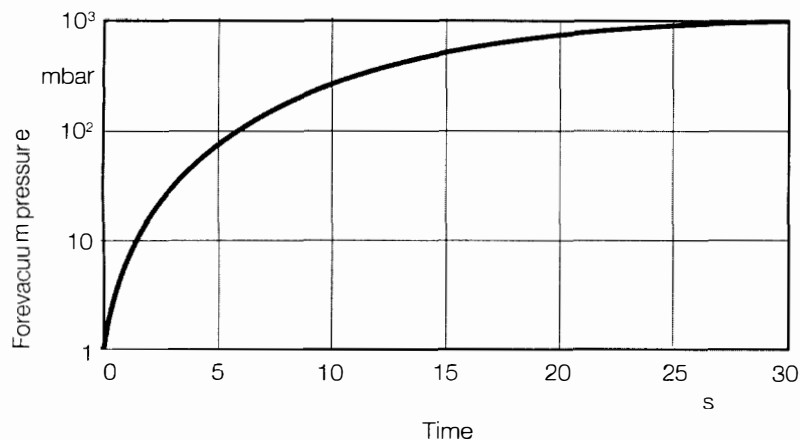

Fig. 4.2 Maximum rise in pressure

4.5 Venting

Refer to Section 4.1 for suited gases.

Venting Methods

There are three different methods of venting the turbomolecular pump.

In the case processes requiring a purge gas, the pump must be vented via the **purge gas and venting valve** when shutting the pump down.

When additionally venting the vacuum chamber, the venting function of the purge gas and venting valve must be opened before opening the chamber valve. This will ensure the presence of a higher pressure in the area of the ball bearings compared to the remaining vacuum area. This will prevent particles, dust or aggressive gases from being forced through the bearings into the not yet vented motor chamber of the pump.

Cautious venting of the pump is possible from the **high vacuum side**, since here the bearing forces will be lowest. When doing so, no free jet of gas must be allowed to form on the rotor so as to avoid exposing the rotor to additional forces.

When venting the pump through its **foreline connection**, neither oil nor particles may be entrained in the gas flow from the forevacuum side into the pump.

Speed of the Pressure Rise

All turbomolecular pumps may be vented at full speed. However, the pressure must not increase faster than specified through the pressure rise curve.

The pump must be vented significantly slower when there is the risk of particles entering into the pump from the process. During venting, the flow must be of the laminar type in both the vacuum chamber and the turbomolecular pump.

The pump must not be vented to pressures above atmospheric pressure.

Speed
Pressure rise curve

Particles

Operation



4.6 Removing the pump from the system

Shut down the pump and vent as described in Sections 4.4 and 4.5.

If the pump has previously handled hazardous gases, implement the proper precautionary measures before opening the intake or exhaust connection.

Observe Safety Informations 0.4.5.

Disconnect the pump only when it has come to a full stop. The green LED at the frequency converter must have gone out.

Then switch the mains power off and wait until the yellow power LED is off. Then only disconnect any cable connections.

Hazardous gases

The pumps may be contaminated with process gases. These gases may be toxic and hazardous to health. In addition, deposits with similarly dangerous properties may have formed. Many of these gases and deposits form acids when they come into contact with humid air. This will result in serious corrosion damage to the pump.

Deposits

Desiccant

To avoid health hazards and corrosion damage when the pumps are detached from the system, fasten a container of desiccant under the transport cover of the high-vacuum connection and then close the pump immediately at all flange connections. Store the pump, with a desiccant, in an airtight PE bag.

Corrosion damage due to faulty packing will nullify the guarantee.

Pack the pump so that it cannot be damaged during shipping and storage. Pay particular attention to protection for the flanges and the electrical plug.

Observe the instructions in Section 5.2 if you forward the pump to Oerlikon Leybold Vacuum.

5 Maintenance

We recommend an exchange of the rotor unit after 80,000 operating hours at the latest.

Such maintenance work can only be done by the Oerlikon Leybold Vacuum Service. If required contact the Oerlikon Leybold Vacuum service center nearest to your location. You can find the address on our internet page www.oerlikon.com.

At high pump loads - for example during cyclic operation, at high gas throughputs or at high ambient temperatures - the aforementioned maintenance work should be carried forward. Please consult Oerlikon Leybold Vacuum for recommendations.

Observe Safety information 0.1.6.

Depending on the degree of contamination of the purge gas used the filter will clog and will have to be exchanged (our experience indicates that this will become necessary after 1 to 6 months).

When an adsorption trap is used, regenerate or renew the adsorption agent regularly; refer to the operating instructions provided with the trap.

5.1 Cleaning

If required clean the turbomolecular pump of dust with a dry cloth.

Cleaning the frequency converter internally

The converter essentially requires no servicing since it contains no components which could be adjusted.

Depending on the installation particulars and the ambient conditions, the converter may collect grime (dust, moisture) on the inside. Such contamination can lead to malfunctions, overheating or short circuits and will have to be avoided to the maximum extent possible. The Oerlikon Leybold Vacuum Service Department can clean the converter. We recommend adhering to a cleaning interval of about five years.

5.2 Oerlikon Leybold Vacuum Service

Whenever you send us in equipment, indicate whether the equipment is contaminated or is free of substances which could pose a health hazard. If it is contaminated, specify exactly which substances are involved. You must use the form we have prepared for this purpose.

A copy of the form has been reproduced at the end of these Operating Instructions: "Declaration of Contamination for Compressors, Vacuum Pumps and Components". Another suitable form is available from www.oerlikon.com → Oerlikon Leybold Vacuum → Documentation → Download Documents.

Attach the form to each pump.

This statement detailing the type of contamination is required to satisfy legal requirements and for the protection of our employees.

Rotor exchange

WARNING



Purge gas filter

Adsorption trap

Contamination

Form

Troubleshooting

We must return to the sender any equipment which is not accompanied by a contamination statement.

CAUTION



6 Troubleshooting

When the connector cable is attached, the outputs at the frequency converter are not free of voltage.

Before you start searching for the source of the problem, you should carry out a few simple checks:

Are the connections in good working order?

- Mains connection,
- 24 V DC cable to the frequency converter,
- Connector cable between the frequency converter and the pump

Is the forevacuum pressure sufficient?

After having removed the cause for the error reset the error message at the TURBO.DRIVE:

- In case of errors with error codes 1 to 7 by applying a STOP signal via the socket REMOTE (X1) or the serial interface or by switching the mains power off.
- In case of error code 8 by switching the mains power off.

The error codes can only be read if a serial interface is present.

The following table has been provided as a guide when determining the causes of errors.

Troubleshooting

Error code	Designation	Meaning	Possible Cause	Remedy	Shut-down
1	Overspeed warning	The actual frequency exceeds the setpoint by over 10 Hz.	Frequency converter defective	Contact Oerlikon Leybold Vacuum Service.	no
2	Pass through time error	The pump has not reached the minimum speed after the maximum run-up time has elapsed.	Forevacuum pressure too high. Gas flow too high Rotor blocked	Check the ultimate pressure of the backing pump and install a bigger backing pump if req. Seal leak, check process Check if the rotor turns freely. Contact Oerlikon Leybold Vacuum Service if the rotor is damaged or blocked.	yes
3	not used				
4	Short circuit error				yes
5	Converter temperature error	Overtemperature at the power output stage or within the frequency converter	Ambient temperature too high Poor cooling	Ensure max. ambient temperature of 45°C Improve cooling	yes
6	Run-up time error	The pump has not reached the normal operating frequency after the maximum run-up time.	Forevacuum pressure too high. Gas flow too high	Check the ultimate pressure of the backing pump and install a bigger backing pump if req. Seal leak, check process	yes
7	Motor temperature error	The motor temperature has exceeded the shut-down threshold.	Forevacuum pressure too high. Gas flow too high Fan defective Water cooling switched off	Check the ultimate pressure of the backing pump and install a bigger backing pump if req. Seal leak, check process Replace fan Switch on water cooling	yes
8	Pump error	Pump couldn't be identified or no pump is connected	Pump not connected correctly to frequency converter Frequency converter software not current, Hardware defective	Check connection between pump and frequency converter Contact Oerlikon Leybold Vacuum Service Contact Oerlikon Leybold Vacuum Service	yes

Troubleshooting

Error code	Designation	Meaning	Possible Cause	Remedy	Shut-down
82	Fan voltage has failed				no
83	Motor temperature low warning				no
84	Motor overtemperature warning				no
101	overload warning	The pump speed has dropped under the normal operation threshold	Forevacuum pressure too high. Gas flow too high	Check the ultimate pressure of the backing pump and install a bigger backing pump if req. Seal leak, check process	no
103	Supply voltage warning	Intermediate circuit voltage too low or maximum time for generator operation was exceeded.	DC supply voltage below 24V Mains voltage has failed	Check the voltage at the power supply and if required set up correctly Remedy the cause for the mains power failure	no
106	overload error	The pump speed has dropped under the minimum speed	Forevacuum pressure too high. Gas flow too high	Check the ultimate pressure of the backing pump and install a bigger backing pump if req. Seal leak, check process	yes
111	Motor under-temperature error	The minimum permissible motor temperature is not attained.	Ambient temperature too low Pump cooling too high	Ensure min. ambient temperature of 0°C Reduce water cooling	yes
116	Permanent overload error	The speed of the pump has dropped below the normal operation threshold and has stayed there for a longer period of time.	Forevacuum pressure too high. Gas flow too high	Check the ultimate pressure of the backing pump and install a bigger backing pump if req. Seal leak, check process	yes
117	Motor current error	Motor current less than nominal current	Cable fault Faulty connector	Contact Oerlikon Leybold Vacuum Service	yes
128	Motor temperature sensor error	Motor temperature sensor defective	Sensor defective, short circuit or broken cable	Contact Oerlikon Leybold Vacuum Service	yes
143	Overspeed error				yes

Troubleshooting

Error code	Error	Possible Cause	Remedy	Shut-down
—	Yellow power LED is not on	No DC power DC power miswired Frequency converter defective	Check cables and power supply Ensure correct polarity of the DC cable. Replace frequency converter. The following may damage the freq. converter: - Disconnection of the DC cable while the pump was still rotating - Non-compliance with the note related to connecting several pump to a single power supply.	—
div.	Red LED flashes	Warning message. See Operating Instructions of the frequency converter for the possible reasons of the warning.	The pump can continue to run, as long as operation limits are only exceeded for a short time. In case of longer exceeding send pump and frequency converter to the OLV service.	no
—	Turbomolecular pump does not start, ERROR LED does not light.	Interface protocol error No communication via the serial interface. REMOTE connector (X1) connected wrongly. REMOTE and SERVICE connectors mixed up. Wrong Profibus address set.	Use USS protocol. Connect bus as shown in the Operating Instructions of the frequency converter. Connect as shown in the Operating Instructions of the frequency converter. Connect correctly. Set address between 0 and 126.	—
—	Turbomolecular pump produces loud running noises and vibrations.	Rotor out of balance Bearing defective	Balance the rotor Replace the bearing	no
—	Turbomolecular pump does not reach ultimate pressure.	Measurement instrument defective Measurement sensors soiled Leaks at the equipment, lines or the pump Pump soiled Forevacuum pump provides insufficient pumping speed or ultimate pressure which is too high. Frequency parameters programmed wrongly	Inspect the measurement sensor Clean or replace the sensors Check for leaks Clean the pump Check the ultimate pressure of the forevacuum pump and install a higher-capacity vacuum pump if necessary Check parameters.	no
—	Running pump can not be stopped via X1	Pump has been started via the serial interface, the interface controls the pump	Disconnect the DC supply or connect serial interface and stop via bus	no

Disposal

Contamination

7 Waste Disposal

The equipment may have been contaminated by the process or by environmental influences. In this case the equipment must be decontaminated in accordance with the relevant regulations. We offer this service at fixed prices. Further details are available on request.

WARNING



Contaminated parts can be detrimental to health and environment. Before beginning with any work, first find out whether any parts are contaminated. Adhere to the relevant regulations and take the necessary precautions when handling contaminated parts.

Separate clean components according to their materials, and dispose of these accordingly. We offer this service. Further details are available on request.

When sending us any equipment, observe the regulations given in Section "5.2 Oerlikon Leybold Vacuum service".

This product complies with with the European Community Regulation 2002/95 (**RoHS** Restriction of Hazardous Substances).

Certificates

The turbomolecular pumps TW 220/150 S, TW 220/150/15 S, TW 250/200/40 S, TW 400/300/25 S and TW 400/300/25 S-PP have been tested by the TÜV Rheinland of North America according to the requirements of

- EN/IEC 61010-1:2001;
- UL 61010-1: 2004 R07.05
- CAN/CSA-C22.2 No.61010-1: 2004 (2nd Edition)

The components are in compliance to the tested standards.

cTUVus File No. 30882228 002

cTUVus Certificate No. CU72081867 sheet 2

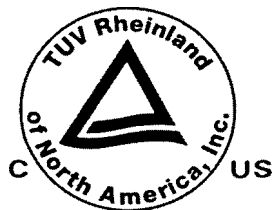

EC Incorporation Declaration

The manufacturer: Oerlikon Leybold Vacuum GmbH
Bonner Straße 498
D-50968 Cologne
Germany
Tel.: +49(0)221 347-0
info.vacuum@oerlikon.com

herewith declares that the following product:

Product designation: **Turbomolecular pump**

Type designation:

TW 220/xxx
TW 250/xxx
TW 400/xxx

Kat.Nr. 11430, 800160Vxxxx x= 0 bis 9

complies with the following fundamental requirements of the **EC Machinery Directive (2006/42/EG)**:
Annex I, Paragraph 1.1.2, 1.1.3, 1.1.5, 1.2.1, 1.2.3, 1.2.4.1, 1.2.4.2, 1.2.6, 1.3.1, 1.3.2, 1.3.3, 1.3.4,
1.3.7, 1.5.1, 1.5.2, 1.5.4, 1.5.5, 1.5.13, 1.6.1 and 1.7.1

The following harmonised standard has been applied:

EN 1012-2:1996+A1:2009 Compressors and vacuum pumps - Safety requirements - Part 2:
Vacuum pumps

The incomplete machine may only be put into operation after it has been determined that the machine into which the incomplete machine shall be installed complies with the regulations laid down in the EC Machinery Directive (2006/42/EG).

The manufacturer commits himself to make the special documentation on the incomplete machine electronically available to national authorities upon request.

The special engineering documentation belonging to the machine was compiled in accordance with Annex VII Part B.

Documentation Officer

Herbert Etges
Tel.: +49(0)221 347-0
Fax: + 49(0)221 347 1250
Documentation.vacuum@oerlikon.com
Oerlikon Leybold Vacuum GmbH
Bonner Straße 498 , D-50968 Cologne
Germany

Cologne, dated 18-7-2011

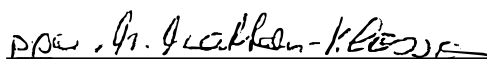
Dr. Monika Mattern-Klosson
Head of Research & Development

Cologne, dated 18-7-2011

Harald Udelhoven
Head of Quality Management

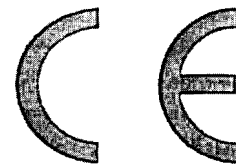

EC Declaration of Conformity

The manufacturer: Oerlikon Leybold Vacuum GmbH
Bonner Straße 498
D-50968 Cologne
Germany
Tel.: +49(0)221 347-0
info.vacuum@oerlikon.com

herewith declares that the products specified and listed below which we have placed on the market, comply with the applicable EC Council Directives.

This declaration becomes invalid if modifications are made to the product without agreement of Oerlikon Leybold Vacuum GmbH.

Compliance with the EMC Directives requires that the components are installed within a system or machine in a manner adapted to EMC requirements.

Product designation: **Turbomolecular pump**

Type designation:

TW 220/xxx
TW 250/xxx
TW 400/xxx

Kat.Nr. 11430, 800160Vxxxx x= 0 bis 9

The product complies to the following European Council Directives:

EC-Directive relating to **electromagnetic compatibility (2004/108/EG)**,
EC-Directive relating to **Low Voltage Directive (LVD) (2006/95/EG)**.

The following harmonised standards have been applied:

EN 61010-1	2001	Safety requirements for electrical equipment for measurement, control and laboratory use - Part 1: General requirements
EN 61326-1	2006	Electrical equipment for measurement, control and laboratory use - EMC requirements - Part 1: General requirements

Cologne, dated 18-7-2011

Cologne, dated 18-7-2011

Dr. Monika Mattern-Klosson
Head of Research & Development

Harald Udelhoven
Head of Quality Management

300301998_002_A0 - 11/2009

Declaration of Contamination of Compressors, Vacuum Pumps and Components

The repair and / or servicing of compressors, vacuum pumps and components will be carried out only if a correctly completed declaration has been submitted. Non-completion will result in delay. The manufacturer can refuse to accept any equipment without a declaration.

A separate declaration has to be completed for each single component.

This declaration may be completed and signed only by authorized and qualified staff.

Customer/Dep./Institute : _____ Address : _____ _____ Person to contact: _____ Phone : _____ Fax: _____ End user : _____	Reason for return: <input checked="" type="checkbox"/> applicable please mark Repair: <input type="checkbox"/> chargeable <input type="checkbox"/> warranty Exchange: <input type="checkbox"/> chargeable <input type="checkbox"/> warranty <input type="checkbox"/> Exchange already arranged / received Return only: <input type="checkbox"/> rent <input type="checkbox"/> loan <input type="checkbox"/> for credit Calibration: <input type="checkbox"/> DKD <input type="checkbox"/> Factory-calibr. <input type="checkbox"/> Quality test certificate DIN 55350-18-4.2.1																																																																
A. Description of the product: _____ Failure description: _____ Material description : _____ Catalog number: _____ Additional parts: _____ Serial number: _____ Application-Tool: _____ Type of oil (ForeVacuum-Pumps) : _____ Application- Process: _____																																																																	
B. Condition of the equipment <table style="width:100%; border-collapse: collapse;"> <thead> <tr> <th style="width:60%;"></th> <th style="width:10%; text-align: center;">No¹⁾</th> <th style="width:10%; text-align: center;">Yes</th> <th style="width:10%; text-align: center;">No</th> <th style="width:10%;"></th> <th style="width:10%;"></th> <th style="width:10%; text-align: center;">No¹⁾</th> <th style="width:10%; text-align: center;">Yes</th> </tr> </thead> <tbody> <tr> <td>1. <u>Has the equipment been used</u></td> <td style="text-align: center;"><input type="checkbox"/></td> <td style="text-align: center;"><input type="checkbox"/></td> <td style="text-align: center;"><input type="checkbox"/></td> <td style="text-align: center;">→</td> <td>toxic</td> <td style="text-align: center;"><input type="checkbox"/></td> <td style="text-align: center;"><input type="checkbox"/></td> </tr> <tr> <td>2. <u>Drained (Product/service fluid)</u></td> <td style="text-align: center;">↓</td> <td style="text-align: center;"><input type="checkbox"/></td> <td style="text-align: center;"><input type="checkbox"/></td> <td></td> <td>corrosive</td> <td style="text-align: center;"><input type="checkbox"/></td> <td style="text-align: center;"><input type="checkbox"/></td> </tr> <tr> <td>3. <u>All openings sealed airtight</u></td> <td style="text-align: center;">↓</td> <td style="text-align: center;"><input type="checkbox"/></td> <td style="text-align: center;"><input type="checkbox"/></td> <td></td> <td>flammable</td> <td style="text-align: center;"><input type="checkbox"/></td> <td style="text-align: center;"><input type="checkbox"/></td> </tr> <tr> <td>4. <u>Purged</u></td> <td></td> <td style="text-align: center;"><input type="checkbox"/></td> <td style="text-align: center;"><input type="checkbox"/></td> <td></td> <td>explosive²⁾</td> <td style="text-align: center;"><input type="checkbox"/></td> <td style="text-align: center;"><input type="checkbox"/></td> </tr> <tr> <td><u>If yes, which cleaning agent</u></td> <td></td> <td></td> <td></td> <td></td> <td>radioactive²⁾</td> <td style="text-align: center;"><input type="checkbox"/></td> <td style="text-align: center;"><input type="checkbox"/></td> </tr> <tr> <td><u>and which method of cleaning</u></td> <td></td> <td></td> <td></td> <td></td> <td>microbiological²⁾</td> <td style="text-align: center;"><input type="checkbox"/></td> <td style="text-align: center;"><input type="checkbox"/></td> </tr> <tr> <td>¹⁾ If answered with "No", go to D. ←</td> <td></td> <td></td> <td></td> <td></td> <td>other harmful substances</td> <td style="text-align: center;"><input type="checkbox"/></td> <td style="text-align: center;"><input type="checkbox"/></td> </tr> </tbody> </table>			No ¹⁾	Yes	No			No ¹⁾	Yes	1. <u>Has the equipment been used</u>	<input type="checkbox"/>	<input type="checkbox"/>	<input type="checkbox"/>	→	toxic	<input type="checkbox"/>	<input type="checkbox"/>	2. <u>Drained (Product/service fluid)</u>	↓	<input type="checkbox"/>	<input type="checkbox"/>		corrosive	<input type="checkbox"/>	<input type="checkbox"/>	3. <u>All openings sealed airtight</u>	↓	<input type="checkbox"/>	<input type="checkbox"/>		flammable	<input type="checkbox"/>	<input type="checkbox"/>	4. <u>Purged</u>		<input type="checkbox"/>	<input type="checkbox"/>		explosive ²⁾	<input type="checkbox"/>	<input type="checkbox"/>	<u>If yes, which cleaning agent</u>					radioactive ²⁾	<input type="checkbox"/>	<input type="checkbox"/>	<u>and which method of cleaning</u>					microbiological ²⁾	<input type="checkbox"/>	<input type="checkbox"/>	¹⁾ If answered with "No", go to D. ←					other harmful substances	<input type="checkbox"/>	<input type="checkbox"/>
	No ¹⁾	Yes	No			No ¹⁾	Yes																																																										
1. <u>Has the equipment been used</u>	<input type="checkbox"/>	<input type="checkbox"/>	<input type="checkbox"/>	→	toxic	<input type="checkbox"/>	<input type="checkbox"/>																																																										
2. <u>Drained (Product/service fluid)</u>	↓	<input type="checkbox"/>	<input type="checkbox"/>		corrosive	<input type="checkbox"/>	<input type="checkbox"/>																																																										
3. <u>All openings sealed airtight</u>	↓	<input type="checkbox"/>	<input type="checkbox"/>		flammable	<input type="checkbox"/>	<input type="checkbox"/>																																																										
4. <u>Purged</u>		<input type="checkbox"/>	<input type="checkbox"/>		explosive ²⁾	<input type="checkbox"/>	<input type="checkbox"/>																																																										
<u>If yes, which cleaning agent</u>					radioactive ²⁾	<input type="checkbox"/>	<input type="checkbox"/>																																																										
<u>and which method of cleaning</u>					microbiological ²⁾	<input type="checkbox"/>	<input type="checkbox"/>																																																										
¹⁾ If answered with "No", go to D. ←					other harmful substances	<input type="checkbox"/>	<input type="checkbox"/>																																																										
C. Description of processed substances (Please fill in absolutely) 1. What substances have come into contact with the equipment ? Trade name and / or chemical term of service fluids and substances processed, properties of the substances According to safety data sheet (e.g. toxic, inflammable, corrosive, radioactive) <table border="1" style="width:100%; border-collapse: collapse; margin-top: 10px;"> <thead> <tr> <th style="width:5%;">X</th> <th style="width:40%;">Tradename:</th> <th style="width:55%;">Chemical name:</th> </tr> </thead> <tbody> <tr><td>a)</td><td>_____</td><td>_____</td></tr> <tr><td>b)</td><td>_____</td><td>_____</td></tr> <tr><td>c)</td><td>_____</td><td>_____</td></tr> <tr><td>d)</td><td>_____</td><td>_____</td></tr> </tbody> </table>		X	Tradename:	Chemical name:	a)	_____	_____	b)	_____	_____	c)	_____	_____	d)	_____	_____																																																	
X	Tradename:	Chemical name:																																																															
a)	_____	_____																																																															
b)	_____	_____																																																															
c)	_____	_____																																																															
d)	_____	_____																																																															
2. Are these substances harmful ? <input type="checkbox"/> No <input type="checkbox"/> Yes ← 3. Dangerous decomposition products when heated ? <input type="checkbox"/> No <input type="checkbox"/> Yes If yes, which ? _____																																																																	
²⁾ Components contaminated by microbiological, explosive or radioactive products/substances will not be accepted without written evidence of decontamination.																																																																	

D. Legally binding declaration

I / we hereby declare that the information supplied on this form is accurate and sufficient to judge any contamination level.

Name of authorized person (block letters) : _____

_____ Date

_____ signature of authorized person

Sales and Service

Germany

Oerlikon
Leybold Vacuum GmbH
Bonner Strasse 498
D-50968 Cologne
Phone: +49-(0)221-347 1234
Fax: +49-(0)221-347 1245
sales.vacuum@oerlikon.com
www.oerlikon.com

Oerlikon
Leybold Vacuum GmbH
Sales Area North/Northeast
Branch Office Berlin
Industriestrasse 10b
D-12099 Berlin
Phone: +49-(0)30-435 609 0
Fax: +49-(0)30-435 609 10
sales.vacuum.bn@oerlikon.com

Oerlikon
Leybold Vacuum GmbH
Sales Area South/Southwest
Branch Office Munich
Karl-Hammerschmidt-Strasse 34
D-85609 Aschheim-Dornach
Phone: +49-(0)89-357 33 9-10
Fax: +49-(0)89-357 33 9-33
sales.vacuum.mn@oerlikon.com
service.vacuum.mn@oerlikon.com

Oerlikon
Leybold Vacuum GmbH
Sales Area West & Benelux
Branch Office Cologne
Bonner Strasse 498
D-50968 Cologne
Phone: +49-(0)221-347 1270
Fax: +49-(0)221-347 1291
sales.vacuum.kn@oerlikon.com

Oerlikon
Leybold Vacuum GmbH
Service Competence Center
Emil-Hoffmann-Strasse 43
D-50996 Cologne-Suerth
Phone: +49-(0)221-347 1538
Fax: +49-(0)221-347 1945
service.vacuum.kn@oerlikon.com

Oerlikon
Leybold Vacuum GmbH
Mobil Customer Service
Emil-Hoffmann-Strasse 43
D-50996 Cologne-Suerth
Phone: +49-(0)221-347 2001
Fax: +49-(0)221-347 1944
service.vacuum.kn@oerlikon.com

Oerlikon
Leybold Vacuum
Dresden GmbH
Service Competence Center
Zur Wetterwarte 50, Haus 304
D-01109 Dresden
Service:
Phone: +49-(0)351-88 55 00
Fax: +49-(0)351-88 55 041
info.vacuum.dr@oerlikon.com

Oerlikon
Leybold Vacuum USA Inc.
5700 Mellon Road
USA-Export, PA 15632
Phone: +1-724-327-5700
Fax: +1-724-325-3577
info.vacuum@oerlikon.com

Europe

Oerlikon
Leybold Vacuum Nederland B.V.
Belgisch bijkantoor
Leuvensesteenweg 542-9A
B-1930 Zaventem
Sales:
Phone: +32-2-711 00 83
Fax: +32-2-720 83 38
sales.vacuum.zv@oerlikon.com
Service:
Phone: +32-2-711 00 82
Fax: +32-2-720 83 38
service.vacuum.zv@oerlikon.com

Oerlikon
Leybold Vacuum France S.A.
7, Avenue du Québec
Z.A. de Courtaboeuf 1 - B.P. 42
F-91942 Courtaboeuf Cedex
Sales und Service:
Phone: +33-1-69 82 48 00
Fax: +33-1-69 07 57 38
info.vacuum.ctb@oerlikon.com
sales.vacuum.ctb@oerlikon.com

Oerlikon
Leybold Vacuum France S.A.
Valence Factory
640, Rue A. Bergès
B.P. 107 640
F-26501 Bourg-lès-Valence Cedex
Phone: +33-4-75 82 33 00
Fax: +33-4-75 82 92 69
marketing.vacuum.vc@oerlikon.com

Oerlikon
Leybold Vacuum UK LTD.
Silverglade Business Park
Leatherhead Road Unit 2
KT9 2QL Chessington, Surrey
(London)
Sales:
Phone: +44-13-7273 7300
Fax: +44-13-7273 7301
sales.vacuum.ln@oerlikon.com
Service:
Phone: +44-13-7273 7320
Fax: +44-13-7273 7303
service.vacuum.ln@oerlikon.com

Italy

Oerlikon
Leybold Vacuum Italia S.r.l.
Via Trasimeno 8
I-20128 Milano
Sales:
Phone: +39-02-27 22 31
Fax: +39-02-27 20 96 41
sales.vacuum.mi@oerlikon.com
Service:
Phone: +39-02-27 22 31
Fax: +39-02-27 22 32 17
service.vacuum.mi@oerlikon.com

Netherlands

Oerlikon
Leybold Vacuum Nederland B.V.
Proostwetering 24N
NL-3543 AE Utrecht
Sales und Service:
Phone: +31-(30) 242 6330
Fax: +31-(30) 242 6331
sales.vacuum.ut@oerlikon.com
service.vacuum.ut@oerlikon.com

Spain

Oerlikon
Leybold Vacuum Spain, S.A.
C/ Huelva 7
E-08940 Cornellà de Llobregat
(Barcelona)
Sales:
Phone: +34-93-666 43 11
Fax: +34-93-666 43 70
sales.vacuum.ba@oerlikon.com
Service:
Phone: +34-93-666 46 16
Fax: +34-93-685 43 70
service.vacuum.ba@oerlikon.com

Switzerland

Oerlikon
Leybold Vacuum Schweiz AG
Leutschenbachstrasse 55
CH-8050 Zürich
Sales:
Phone: +41-44-308 40 50
Fax: +41-44-302 43 73
sales.vacuum.zh@oerlikon.com
Service:
Phone: +41-44-308 40 62
Fax: +41-44-308 40 60
service.vacuum.zh@oerlikon.com

America

Oerlikon
Leybold Vacuum USA Inc.
5700 Mellon Road
USA-Export, PA 15632
Sales:
Phone: +1-724-327-5700
Fax: +1-724-325-1217
info.vacuum.ex@oerlikon.com
Service:
Phone: +1-724-327-5700
Fax: +1-724-333-3577
info.vacuum.ex@oerlikon.com

Asia

P.R. China

Oerlikon
Leybold Vacuum (Tianjin)
International Trade Co. Ltd.
Beichen Economic
Development Area (BEDA),
No.8 Western Shuangchen Road
Tianjin 300400
China
Sales und Service:
Phone: +86-22-2697 0808
Fax: +86-22-2697 4061
Fax: +86-22-2697 2017
info.vacuum.tj@oerlikon.com
sales.vacuum.tj@oerlikon.com
service.vacuum.tj@oerlikon.com

Oerlikon
Leybold Vacuum
(Tianjin) Co. Ltd.
Beichen Economic
Development Area (BEDA),
No.8 Western Shuangchen Road
Tianjin 300400
China
Sales und Service:
Phone: +86-22-2697 0808
Fax: +86-22-2697 4061
info.vacuum.tj@oerlikon.com
service.vacuum.tj@oerlikon.com
sales.vacuum.tj@oerlikon.com

Oerlikon
Leybold Vacuum (Tianjin)
International Trade Co. Ltd.
Shanghai Branch:
48F InterContinental
Business Center
100 Yutong Road
Shanghai 200070
China
Sales und Service:
Phone: +86-21-5288 5888
Fax: +86-21-5288 5836
info.vacuum.sh@oerlikon.com
service.vacuum.sh@oerlikon.com
sales.vacuum.sh@oerlikon.com

Oerlikon
Leybold Vacuum (Tianjin)
International Trade Co. Ltd.
Guangzhou Office and
Service Center
1st F, Main Building
Science City Plaza,
No.111 Science Revenue,
Guangzhou Science City
(GZSC) 510663, Guangzhou,
China
Sales und Service:
Phone: +86-20-223 23 980
Fax: +86-20-223 23 990
info.vacuum.gz@oerlikon.com
service.vacuum.gz@oerlikon.com
sales.vacuum.gz@oerlikon.com

Oerlikon
Leybold Vacuum (Tianjin)
International Trade Co. Ltd.
Beijing Branch:
1-908, Beijing Landmark Towers
8 North Dongsanhuan Road
Beijing 100004
China
Sales:
Phone: +86-10-6590-7622
Fax: +86-10-6590-7607
sales.vacuum.bj@oerlikon.com
service.vacuum.bj@oerlikon.com

India

Oerlikon
Leybold Vacuum India Pvt Ltd.
EL 22, J-Block
MIDC Bhosari
Pune 411026
India
Sales und Service:
Phone: +91-20-3061 6000
Fax: +91-20-2712 1571
sales.vacuum.pu@oerlikon.com
service.vacuum.pu@oerlikon.com

Japan

Oerlikon
Leybold Vacuum
Japan Co., Ltd.
Headquarter
23-3, Shin-Yokohama
3-chome
Tobu A.K. Bldg. 4th Floor
Kohoku-ku
Yokohama-shi 222-0033
Sales:
Phone: +81-45-471-3330
Fax: +81-45-471-3323
info.vacuum.yh@oerlikon.com
sales.vacuum.yh@oerlikon.com

Oerlikon
Leybold Vacuum
Japan Co., Ltd.
Osaka Sales Office
3F, Shin-Osaka Terasaki
No.3 Bldg.
1-5-28 Nishi-Miyahara
Yodogawa-ku, Osaka-shi
Osaka 532-0004
Phone: +81-6-6399-6271
Fax: +81-6-6399-6273
info.vacuum.os@oerlikon.com
sales.vacuum.os@oerlikon.com

Oerlikon
Leybold Vacuum
Japan Co., Ltd.
Tsukuba Technical Service Center
1959, Kamiyokoba
Tsukuba, Ibaraki,
305-0854 Japan
Service:
Phone: +81-29 839 5480
Fax: +81-29 839 5484
info.vacuum.iik@oerlikon.com
service.vacuum.iik@oerlikon.com

South Korea

Oerlikon
Leybold Vacuum Korea Ltd.
3F, Jellzone 2 Tower
Jeongja-dong 159-4
Bundang-gu Sungnam-si
Gyeonggi-do
Bundang 463-384, Korea
Sales:
Phone: +82-31 785 1367
Fax: +82-31 785 1359
sales.vacuum.bd@oerlikon.com

Service:
623-7, Upsung-Dong
Cheonan-Si
Chungcheongnam-Do
Korea 330-290
Phone: +82-41 589 3035
Fax: +82-41 588 0166
service.vacuum.cn@oerlikon.com

Singapore

Oerlikon
Leybold Vacuum
Singapore Pte Ltd.
1 Science Park Road
Singapore Science Park 2
#02-12, Capricorn Building
Singapore 117528
Sales und Service:
Phone: +65-6303 7030
Fax: +65-6773 0039
sales.vacuum.sg@oerlikon.com
service.vacuum.sg@oerlikon.com

Taiwan

Oerlikon
Leybold Vacuum Taiwan Ltd.
No 416-1, Sec. 3
Chunghsin Road, Chutung
Hsinchu County 310
Taiwan, R.O.C.
Sales und Service:
Phone: +886-3-500 1688
Fax: +886-3-583 3999
sales.vacuum.hc@oerlikon.com
service.vacuum.hc@oerlikon.com