

Pendulum Gate Valve Rebuild Procedure

Rev. B, April, 2006

This procedure covers the Nor-Cal Pendulum Gate Valve rebuild, with the gate valve housing installed on the system. This procedure applies to 200mm, 250mm, and 350mm Gate Valves, including the Throttling Gate Valve (TPV) and Standard & Symmetric (mirror-image) versions. Please note where the differences are pointed out. This procedure should be read in its entirety before performing any tasks.

Table of Contents

Introduction, Safety and Handling	2
Section 1 – Tools And Materials.....	4
Section 2 – Spare Parts.....	5
Section 3 – Grease and Torque Standards.....	6
Section 4 – Gate Assembly Removal.....	7
Section 5 – Disassembly and Cleaning of the Gate Assembly.....	13
Section 6 – Reassembling the Gate Assembly.....	19
Section 7 – O-Ring Removal and Installation.....	28
Section 8 – Actuator and Gate Arm Shaft Removal.....	29
Section 9 – Reassembly of the Shaft.....	36
Section 10 – Gate Arm Height Adjustment.....	40
Section 11 – Replacing the Hard Stop.....	42
Section 12 – Gate Assembly Installation.....	45
Section 13 – TPV Sensors and Settings.....	48
Section 14 – IPV Pneumatic Sensors and Settings.....	51

Appendix A – Spare Parts Lists



FOR SALES AND SERVICE PLEASE CALL:

PTB SALES T :: 626.334.0500
 service@ptbsales.com
 www.ptbsales.com

DATE SERVICED: _____

VIEW OUR INVENTORY

Gate Valve Rebuild Procedure Rev. B April, 2006

Introduction, Safety and Handling

Introduction

The Nor-Cal **Intellisys**™ line of Pendulum Gate Valves includes several different size valves and 2 different manufacturers.

This procedure is designed to help protect and extend the working life of your investment. Only qualified and competent technicians should handle this valve, and critical care must be taken to prevent damage once the valve is opened. As an accompaniment to this procedure, a series of training videos is available detailing each step in the process.

This document defines the size of the valve by the main bore, not by the wafer size produced in the tool. This manual covers the rebuild procedure for 200mm, 250mm and 350mm Pendulum Gate valves produced by Nor-Cal Products. It also covers older valves formerly produced by the V-TEX Corporation of Japan.

There are many different sizes and configurations of Nor-Cal Pendulum Gate Valves. The photos shown throughout this document are for reference only, and might not be representative of the specific valve you are working on. Please note where the differences are pointed out.

Safety

There are 5 basic icons used throughout this document:



DANGER – Bodily injury may occur if these procedures are not followed.



CAUTION – Damage to the Gate Valve may occur if these procedures are not followed.



NOTE – Special instructions to clarify, highlight, or help the technician.



Good or Bad – Indicates correct or incorrect visual inspection of the instructions.



Do Not – Indicates that this item should not be used or not be performed.

Examples of these icons are on the following page:

Examples:



Keep hands and fingers clear of the valve flange when it is connected to air pressure lines or motor drive cables.



Do not get FFRM grease inside the valve body or on the gate assembly. It is not vacuum-safe grease.



If the bearing is not on the shaft, it is most likely still encased inside the housing.

Handling

To prevent contamination from fingerprints or other non-UHV substances, latex gloves and clean tools must be used for handling and adjustment of all pendulum components. Changing gloves frequently during this procedure is strongly recommended.

All parts must be handled carefully to avoid scratches that may damage the machined sealing surfaces, *ESPECIALLY ALUMINUM PARTS*.

Never lift the Gate Valve using the Actuator as a lift point. Permanent damage can result. Always lift the valve by the edges of the body, and have another person help if needed.

Preventive Maintenance Schedule:

Nor-Cal USA -made Valves:

- Every 10,000 wafers, replace the Gate Seal
- Every 30,000 wafers, clean, re-grease, and rebuild the Gate Assembly, remove, clean and inspect the Hard Stop for excessive wear or process damage, and replace the Hard Stop O-ring.
- Every 60,000 wafers, rebuild the main shaft assembly

VTEX Japan-made Valves:

- Every 10,000 wafers, replace the Gate Seal, and clean, re-grease, and rebuild the Gate Assembly
- Every 30,000 wafers, rebuild the main shaft assembly, remove and clean the Hard Stop, and replace the hard stop o-ring.



The Nor-Cal Gate valve operates with significant speed and torque.

There is a severe crushing hazard. Serious injury can result.

Please observe all Danger and Caution warnings, and keep hands and fingers clear of the valve flange when it is connected to air pressure lines or electrical cables.



After cleaning all parts and surfaces with IPA, a DI wipe may be required to remove IPA residue. Prepare a table or working surface with disposable cleanroom wipes to lay parts on.

Section 1

Tools & Materials Required



Nor-Cal Pendulum Valve Tool Kit (AMAT P/N 3870-03699)

The Nor-Cal Pendulum Valve Tool Kit Contains:

- Torque wrench set (0-450 in-lbs., NIST traceable)
- Modified Metric Allen wrench set (2.5mm - 10mm)
- Long-shank M5, M6 M8, M10 hex socket drivers
- Reversible standard/Phillips screwdriver #1
- Non-metallic O-ring Removal Tools
- Gate Arm Height Adjustment Gauges
- Loctite No. 222 Part No. 5010-01028
- Cleanroom approved swabs
- Modified bearing puller
- FFRM bearing grease sample and 2 oz. Krytox LVP and 240AC grease tubes
- C-ring (snap-ring) pliers
- Spring pulling hook
- Multiple use wrench (“Super Wrench”)
- SAE T-Handle Allen wrenches for Pneumatic speed adjustments
- Hard Stop removal tool
- CD-ROM Documentation and Video Training

NOTE

All bolts on the Pendulum valves are Metric.

All torque values are listed in in-lb.
To convert in-lb to N.m
Multiply by 0.113

Example:
 $65 \text{ in-lb} \times 0.113 = 7.23 \text{ N.m}$

The Pendulum Valve Tool Kit is strongly recommended for any location servicing Gate Valves. It is available from Nor-Cal Products and through AMAT (P/N 3870-03699), and contains all the tools necessary to perform Gate Valve Maintenance on each size of valve. It comes with a fully loaded documentation CD-ROM, including video training (playable on a PC) of the entire rebuild procedure.

In addition to the tools above, latex gloves, cleanroom wipes, Isopropyl Alcohol (IPA) and De-Ionized (DI) water are required for cleaning and handling the valve.

Section 2
Spare Parts Available

[Please refer to Appendix A for a complete list of spare parts]

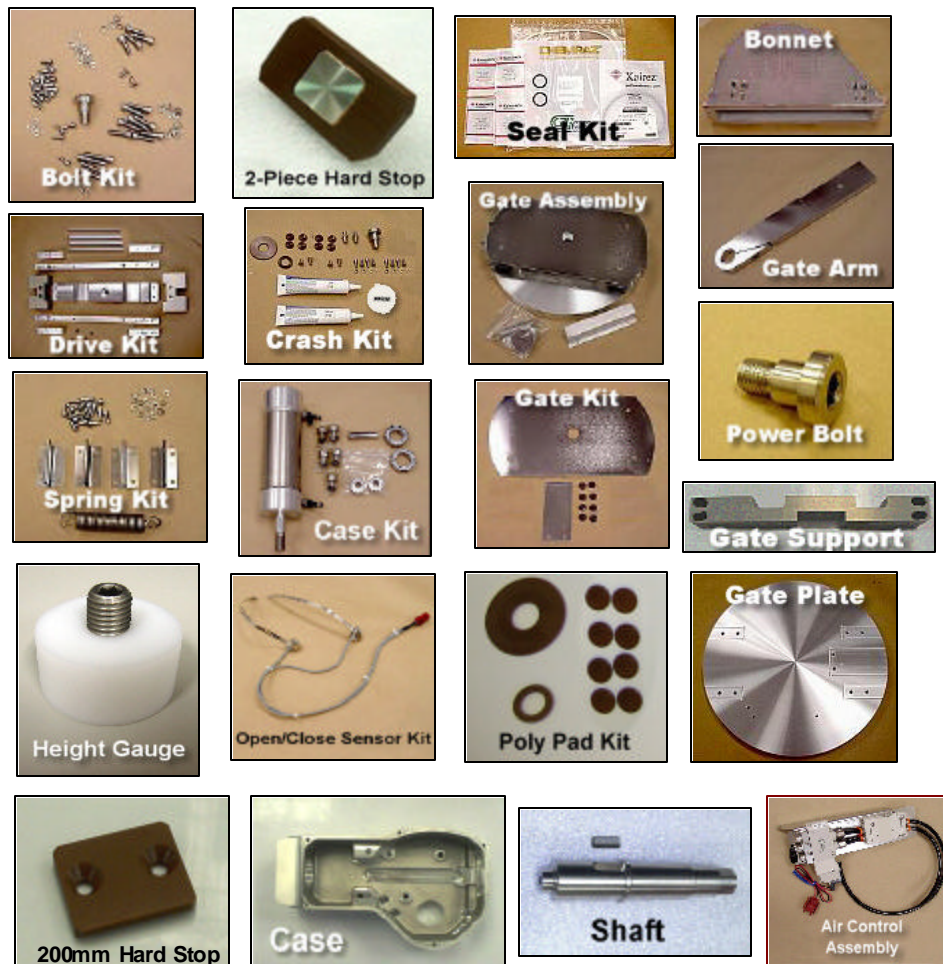

Photos of Spares & Kits

NOTE: Spares Kit photos are examples only.
 Kits for specific valve configurations may vary accordingly

[Figure 2-A, Spare Part Kits Photos]

Section 3
Grease and Torque Standards

This section covers the requirements for the amount of grease to be applied when reassembling the gate valve. Since there is a possibility for additional particles generated with excessive grease application, it is important to follow the guidelines listed below. Additionally, this section includes the torque standards for installing hardware.

- 3.1 The assembly section will refer to the standard for grease application as "one bead."
- 3.2 One bead of Krytox® LVP or 240-AC should be a sphere, approximately 3mm in diameter, applied from a tube (Figure 3-A)
- 3.3 DI water should be used as a lubricant for bolts. Never use grease on bolts.

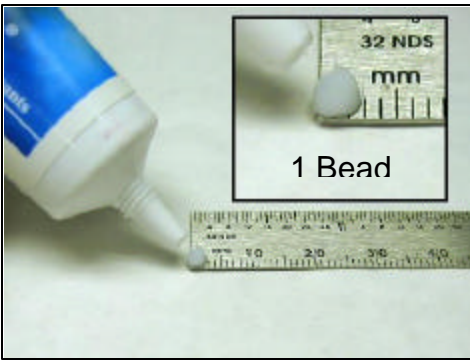

[Figure 3-A, Standard Grease Amount]

Location	Type	AMAT P/N
Shaft Seals	Krytox LVP	5070-01029
Shaft Bearings	Multemp FFRM*	5070-00015
Crank Arm, Knuckle, Case	Multemp FFRM*	5070-00015
Gate Assembly Driving Rollers	Krytox 240AC	5070-01013
Hard Stop O-ring	No Grease – IPA + DI Wipe Only	
Gate Seal O-Ring	No Grease – IPA + DI Wipe Only	
Bonnet Seal O-Ring	No Grease – IPA + DI Wipe Only	
* NOTE: In USA Made, Nor-Cal valves, Lubriplate grease can replace FFRM grease.		

[Table T-1, Grease Types and Locations]

	350mm	250mm	200mm
Fastener Description	Torque (in.-lbs.)	Torque (in.-lbs.)	Torque (in.-lbs.)
Crank Arm Hex Socket Head Bolt	130	130	130 (65 for Flag-Pole)
Crank Arm Hex Socket Head Set Screws	100	100	100
Actuator (Case fixing) Hex Socket Head Bolts	160	130	130
Bearing Flange / Shaft Guide Housing Hex Socket Head Bolts	65	35	35
Plate Spring Hex Socket Head Bolts	20	15	15
Holder Hex Socket Head Bolts	70	50	30
Touch Plate Flat Hex Socket Head Screws	30	30	30
Gate Arm Hex Socket Head Bolt	210	130	65
Hard Stop Hex Head Bolts	*	*	30
Power Bolt (Hex Socket Head)	450	350	150
Spring Cover Plate Captive Hex Socket Head Bolts	25	25	25
Bonnet Captive Hex Socket Head Bolts	100	100	100
Connecting Bar Hex Socket Head Bolts	70	50	30
Gate Stopper Hex Socket Head Bolts	50	25	15
Gate Supporter Hex Socket Head Bolt	70	n/a	n/a
* Torque Values for Hard Stop Hex Head Bolts			
<u>Hard Stop Material</u>	<u>350mm Gate Valve</u>	<u>250mm Gate Valve</u>	
Vespel (USA, Nor-Cal)	30 in-lb	30 in-lb	
Stainless Steel (Japan, V-Tex)	70 in-lb	70 in-lb	

Section 4

Gate Assembly Removal

- 4.1 Open the Gate Valve
- 4.2 Follow the prescribed venting procedure to vent the process chamber. Before continuing, check the turbo controller to confirm the turbo is spun down (0 rpm or wait at least 30 minutes for Shimadzu turbo pumps.)
- 4.3 Vent the turbo pump by removing the VCR cap on the turbo isolation valve. Reinstall the VCR cap with a new VCR gasket once atmospheric pressure in the turbo pump is reached.

! CAUTION !

There may be a pressure difference between the turbo pump and the chamber. Maximum differential pressure across the 350 gate during actuation is **29 Torr**. Maximum differential pressure across the 250 gate during actuation is **24 Torr**. Maximum differential pressure across the 200 gate during actuation is **20 Torr**. I.E., the ΔP between the turbo and the chamber is not to exceed these values when actuating the gate valve. Actuating the gate valve at pressures in excess of this maximum will cause permanent damage and invalidate the warranty.

- 4.4 Return the Gate Valve to the closed position, and remove the Bonnet by loosening the captive bonnet bolts.

For Pneumatically actuated Isolation Valves, Skip to section 4.6, "Retracting the Gate on a Pneumatically Actuated Valve"

- 4.5 For IQ and motor-driven throttling valves, remove all cables to the motor, and use a screwdriver in the end of the belt cover to retract the gate. Counter-Clockwise rotation opens the Gate, and clockwise motion closes the Gate.

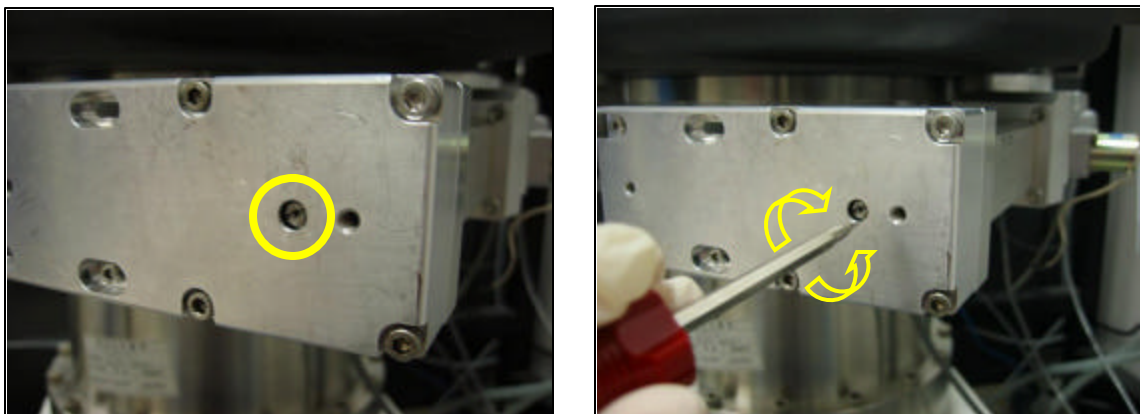

[Figure 4-A, Belt Cover and screwdriver rotation]

CAUTION

The Actuator and motor linkage are subject to permanent damage if handled improperly. Never use the motor or actuator as a handle to lift the valve. Serious damage may result. Never rest the valve on the motor or actuator when unpacking, moving or servicing the valve, and avoid hitting the motor against heavy objects.

Under normal service and preventive maintenance conditions, the motor linkage and actuator assembly will not have to be disassembled or removed from the valve.

However under certain conditions, the motor and belt pulley may need to be removed for service. Please refer this type of service to a trained and qualified technician.

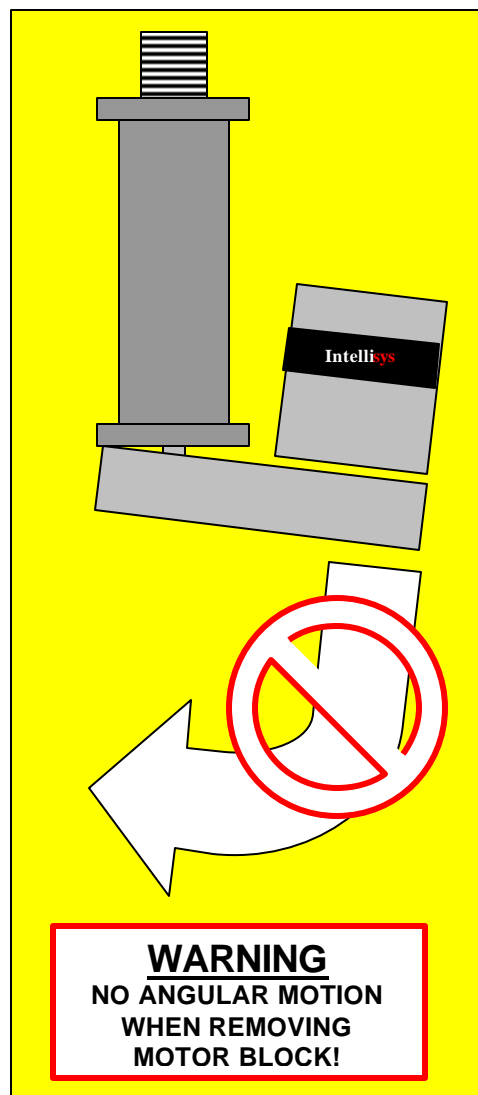

Retracting the Gate on a Pneumatically Actuated Valve

- 4.6 Open the gate valve manually by pressing and holding the orange button on the Air Control Assembly, mounted next to the piston cylinder case housing. Use an o-ring pick or small Allen wrench to operate the button.



With the bonnet removed, the gate assembly will protrude out of the opening of the gate valve body in the open position. Keep personnel clear of the bonnet opening when manually opening the gate valve.

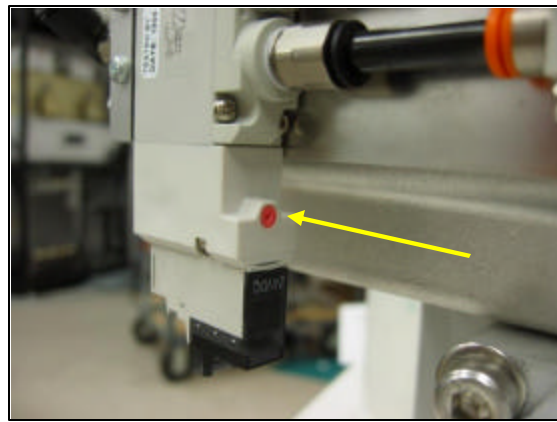
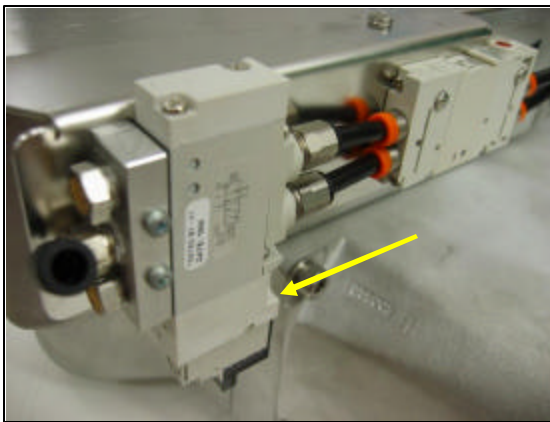

[Figure 4-B, Gate Valve Pneumatics]

- 4.7 Remove the main air supply line and pinch it off as soon as the gate valve is open.

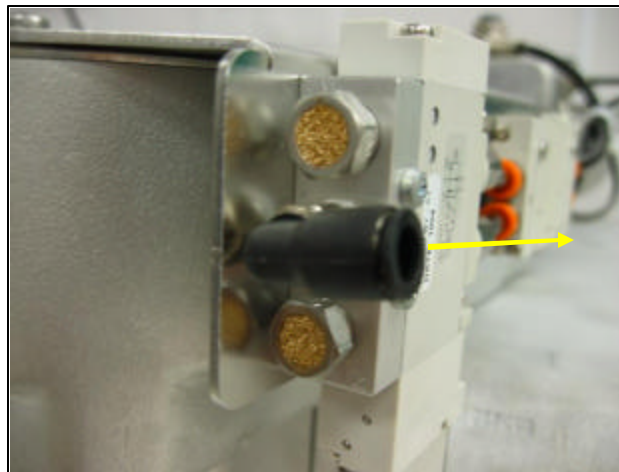

[Figure 4-C, Remove the main air supply line]

- 4.8 With the main air line removed, vent the cylinder by pressing and holding the red button on the air control bracket for ~20 seconds. Then remove the open and close air lines from the Air Control Assembly. This will allow the actuator to move freely.

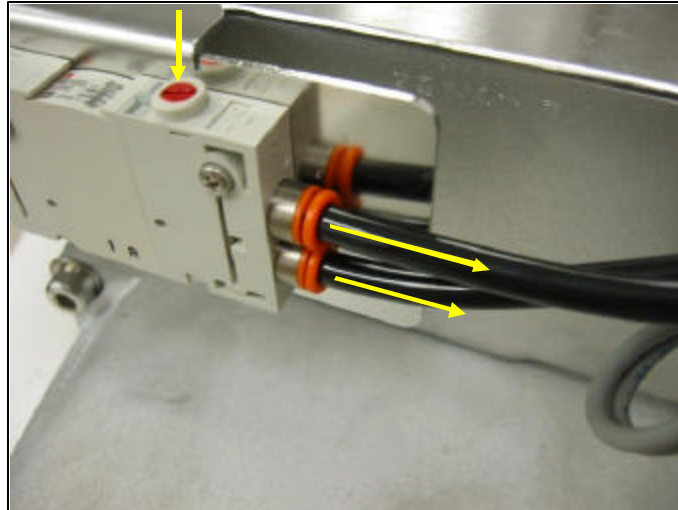

[Figure 4-D, Vent the Cylinder and remove the air lines]

Removing the Gate Assembly from the valve

- 4.9 Loosen the two captive bolts from the spring cover on bottom of gate assembly [A] and remove spring using the spring hook removal tool, or a plastic zip-tie [B]. To prevent scratching the gate, never use a metal screwdriver or other unapproved tool.

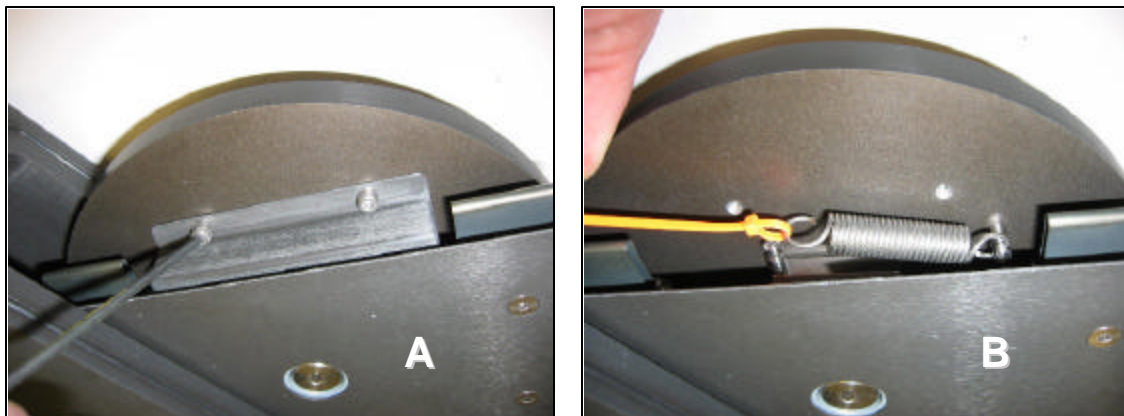

[Figure 4-E, Gate Valve Spring Assembly]

- 4.10 Using the appropriate long shank, hex socket driver, remove Power Bolt and Power Bolt Washer from the bottom center of the Gate assembly.

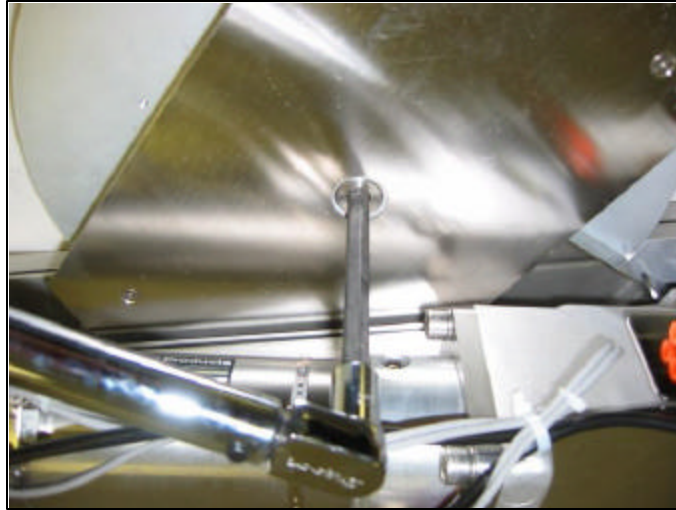

[Figure 4-F, Removing the Power Bolt]



If the Power Bolt does not come out easily, do not force it out. Use DI water as a lubricant, by squirting it into the threads. Ease-out the Power Bolt by using a back & forth motion and large amounts of DI to slowly work it out. Inspect the Power Bolt and Gate Arm as in step 4.12

- 4.11 Do not remove the touch plate at this time. Remove the Gate from the Gate Arm by lifting the Gate off the arm and sliding it out, being careful not to scratch the Gate in the process.

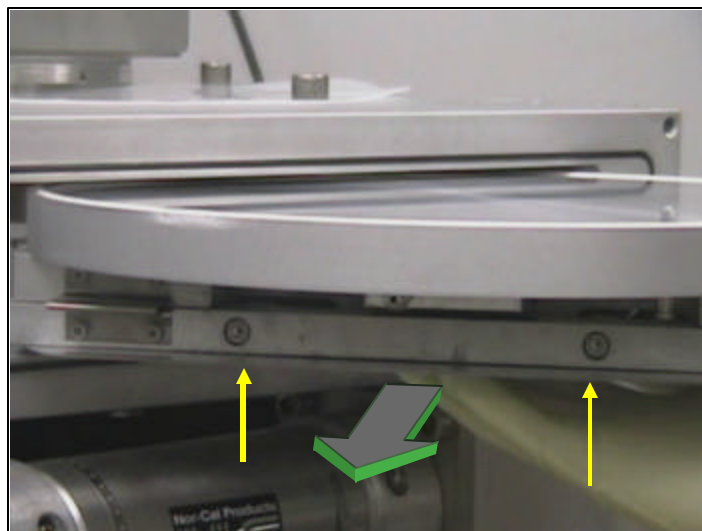

[Figure 4-G, Lift-up and slide-out the Gate Assembly]

- 4.12 Inspect Power Bolt threads and note their integrity. Inspect Gate Arm threads and note the presence of any particles. Thoroughly clean any particles from Power Bolt threads and Gate Arm threads with IPA or DI, and cleanroom wipes, until no trace of particles is left in either.

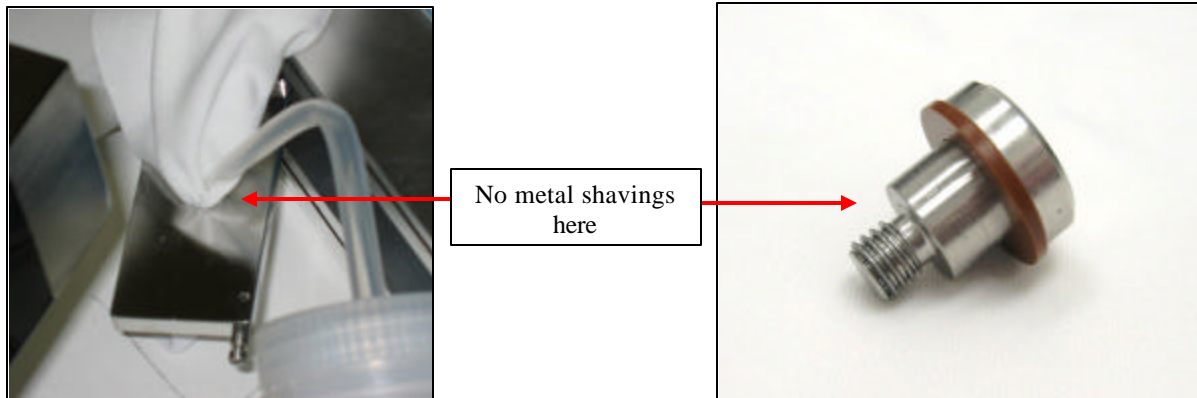

[Figure 4-H, Check the Power Bolt threads for metal shavings]

- 4.13 Inspect the Gate arm and Power Bolt for past over torque damage. Look for damaged threads on the Power Bolt and for a “mushroomed” shoulder where the unthreaded portion has expanded. In the Gate Arm, look for a small recess where the Power Bolt has dug-in to the Arm (Fig 4-I below.) If either of these conditions is present, the Gate Plate may not rotate properly. See Section 12.4 for information on proper Gate rotation.

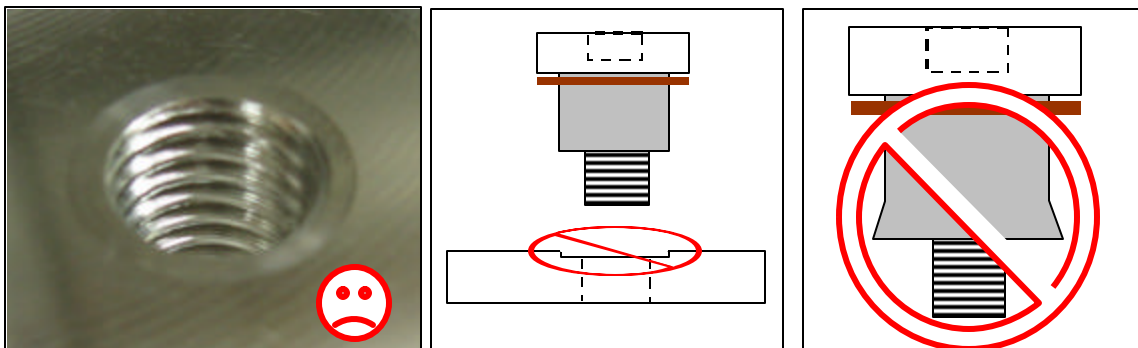

[Figure 4-I, Inspect the Gate Arm and Power Bolt for over torque damage.]

- 4.14 Test the condition of the Power Bolt by threading the entire length into and out of the Gate Arm thread by hand. If the Power Bolt does not move freely throughout the travel, there may be metal shavings in the threads. In this case, loosen Power Bolt, clean all threads and re-try. If this does not solve the problem, try a new Power Bolt. If still, this does not solve the problem, the Gate Arm threads are damaged. Replace both the Gate Arm and Power Bolt.

Section 5
Disassembly and Cleaning of the Gate Assembly

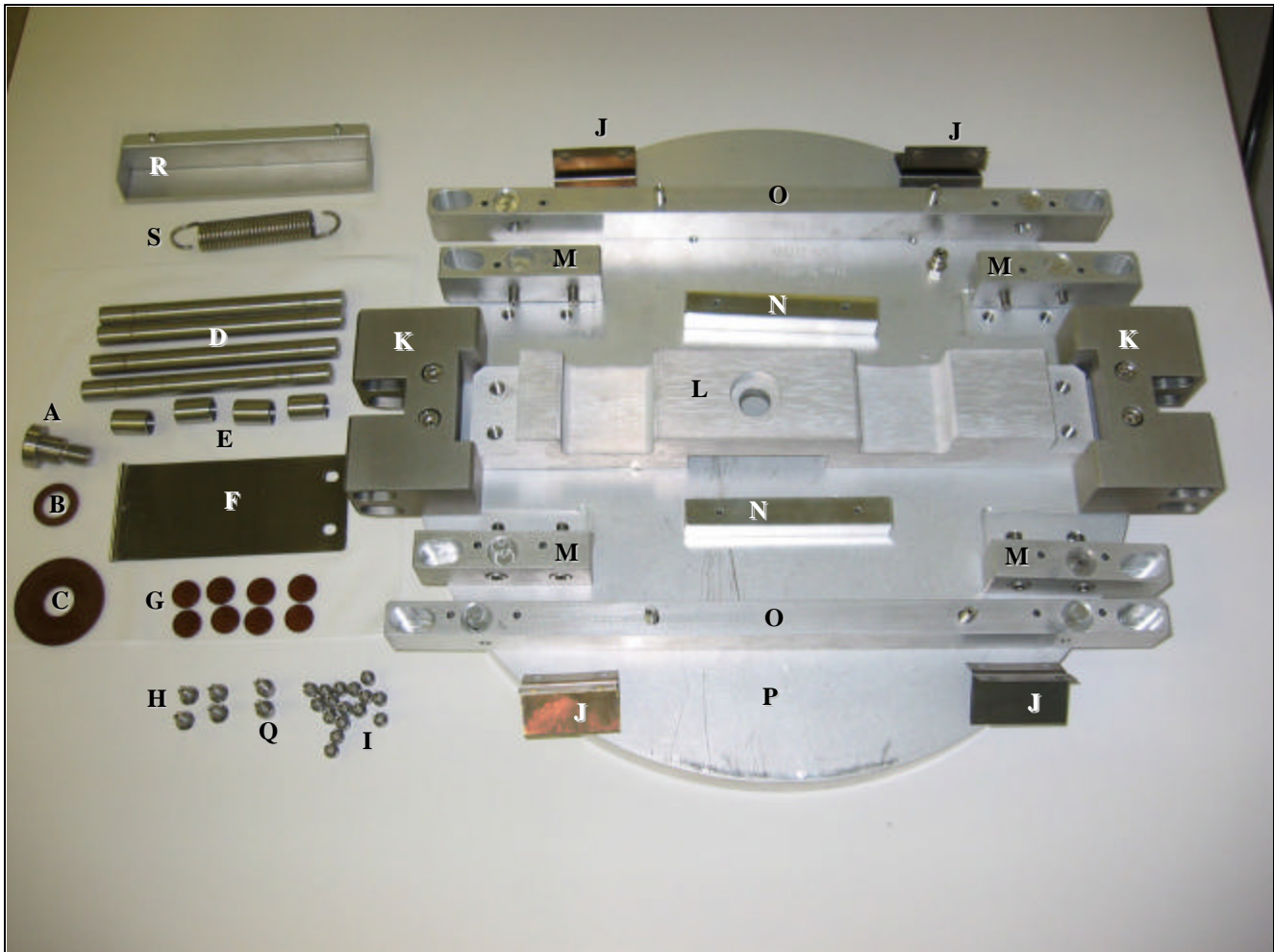

[Figure 5-A, Gate Assembly Exploded View]

<u>Item</u>	<u>Description</u>	<u>Item</u>	<u>Description</u>
A	Power Bolt	K	Driving Pieces (350 Only)
B	Polyimide Power Bolt Washer	L	Gate Support (Driving Bar in 350)
C	Polyimide Rotary Pad	M	Holders (4)
D	Rollers (4)	N	Connecting Bars (2)
E	Protect Pipes (4) 350 Only	O	Counter Plates (2)
F	Gate Stopper	P	Gate Plate
G	Polyimide Slide pads (8)	Q	Gate Stopper Bolts (2)
H	Flat Head Touch Plate Screws (4)	R	Coil Spring Cover
I	Plate Spring Screws (16)	S	Coil Spring
J	Plate Springs (4)		

[Table T2, Gate Assembly Exploded View Legend]

Recommended Cleaning and Rebuilding (Preventive Maintenance) Kit
 (Recommended at each PM interval)

Crash Kit

VTEX 250mm Crash Kit	3870-03586
VTEX 350mm Crash Kit	3870-03570

N-C 200mm Crash Kit	3870-04175
N-C 250mm Crash Kit	3870-04678
N-C 350mm Crash Kit	3870-04681

Recommended Gate Assembly refurbishing and parts replacement kits
 (Replace on failure, or as needed per inspection to prevent failure)

Drive Kit

VTEX 250mm Drive Kit	3870-03589
VTEX 350mm Drive Kit	3870-04675

N-C 200mm Drive Kit (STD)	3870-04179
N-C 200mm Drive Kit (SYM)	3870-04185
N-C 250mm Drive Kit	3870-04679
N-C 350mm Drive Kit	3870-04682

Spring Kit

VTEX 250mm Spring Kit	3870-03588
VTEX 350mm Spring Kit	3870-03574

N-C 200mm Spring Kit	3870-04177
N-C 250mm Spring Kit	3870-03683
N-C 350mm Spring Kit	3870-03601

Poly Pad Kit

VTEX 250mm Poly Pad Kit	N/A
VTEX 350mm Poly Pad Kit	N/A

N-C 200mm Poly Pad Kit	N/A
N-C 250mm Poly Pad Kit	N/A
N-C 350mm Poly Pad Kit	N/A

Power Bolt

VTEX 250mm Power Bolt	3870-00926
VTEX 350mm Power Bolt	3870-00945

N-C 200mm Power Bolt	3870-04188
N-C 250mm Power Bolt	3870-03696
N-C 350mm Power Bolt	3870-03614

- 5.1 Place the Gate Assembly with the o-ring side down on a clean wipe and remove the 4 flat-head Touch Plate screws and the Touch Plate. Inspect the Touch Plate for damage such as scratches or bending, as shown in Fig 5-B.

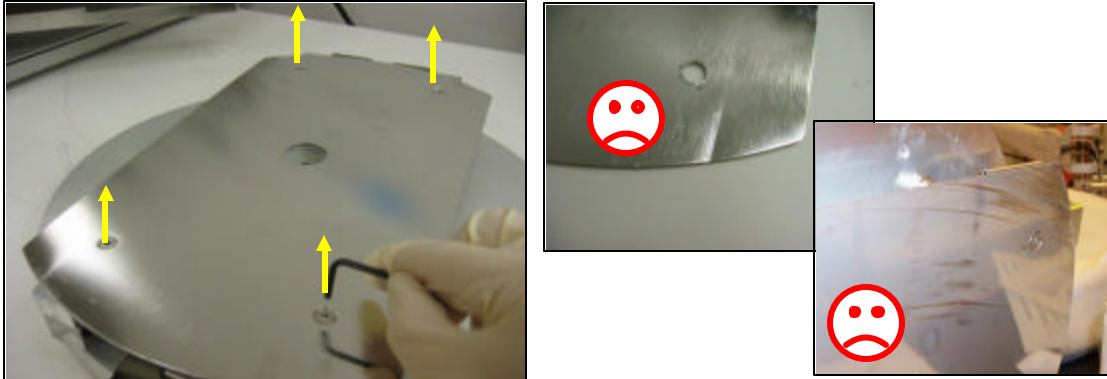

[Figure 5-B, Removing and inspecting the Touch Plate]

- 5.2 Completely remove all 4 Plate Springs from the Counter Plates and Holders.

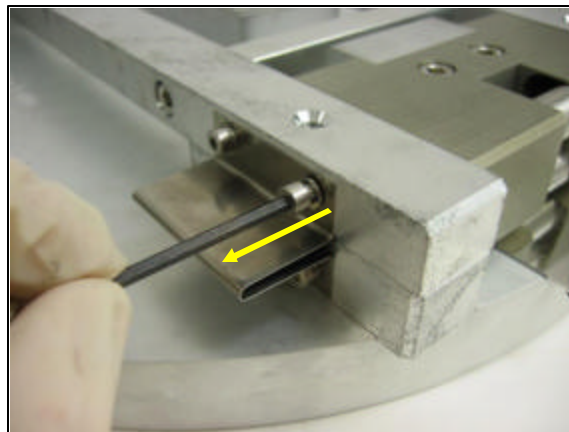

[Figure 5C, Removing the Touch Plate Screws]

- 5.3 Remove four bolts holding the Counter Plates together with the Connecting Bars (square cross pieces).

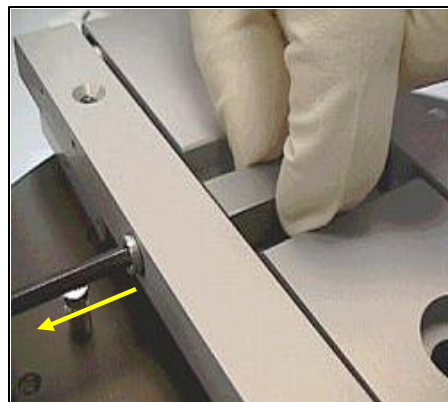

[Figure 5-D, Removing Connecting Bar bolts]

- 5.4 Remove the Counter Plates by pulling on both ends equally and removing them straight. The Counter Plates should come off easily. Avoid rocking the Counter Plates back & forth to remove them. Never use a hammer or pry-bar to remove the Counter Plates.

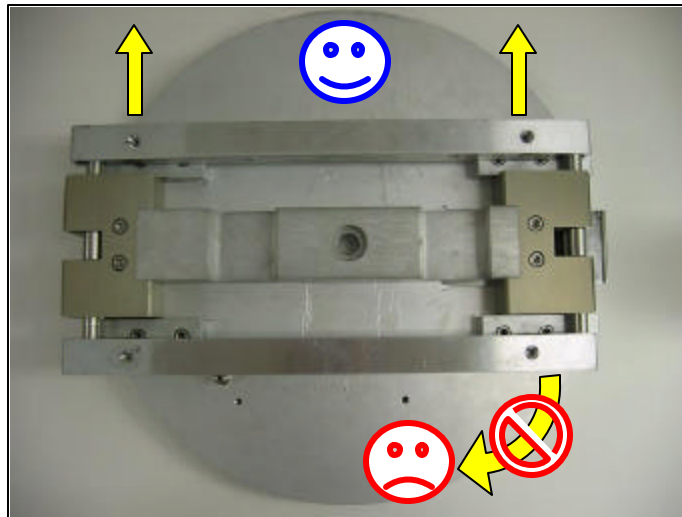

[Figure 5-E, Remove Counter plates straight]

- 5.5 Remove the eight Holder bolts fastening the four Holders. Lift up on the Gate Support and remove the Holders. Never write on the holders – they will stain.

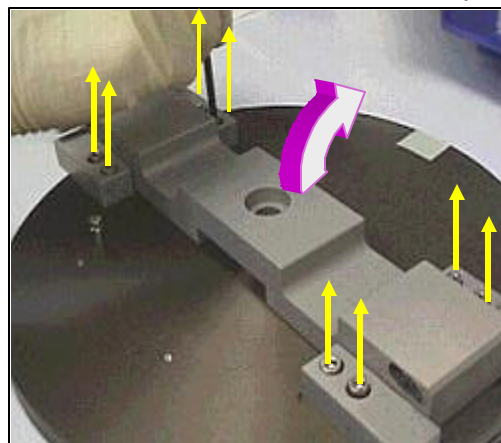

[Figure 5-F, Removing the Holders]

- 5.6 Remove the four Rollers and the Protect Pipes (350 only.) Finally, lift the Gate Supporter clear of the Gate Plate.

- 5.7 Inspect the Gate Stopper assembly for damage (refer to damaged Gate Stopper in Figure 5-G). Look for a crushed or bent pipe on the end, and any bending of the flat arm that attaches to the Gate. If there is significant damage, replace the Gate Stopper assembly



[Figure 5-G, Check for Gate Stopper Damage]

- 5.8 Remove all Polyimide Slide Pads including the large Rotary Pad underneath the gate Support, using cleanroom tape. Avoid using a metal tool to remove the pads, as it can scratch the Aluminum or destroy the pad. Clean off any grease. When re-installing Pads, do not use grease. Slide Pads should be replaced if they are worn flush with the metal surface, or the rounded edge is worn flat

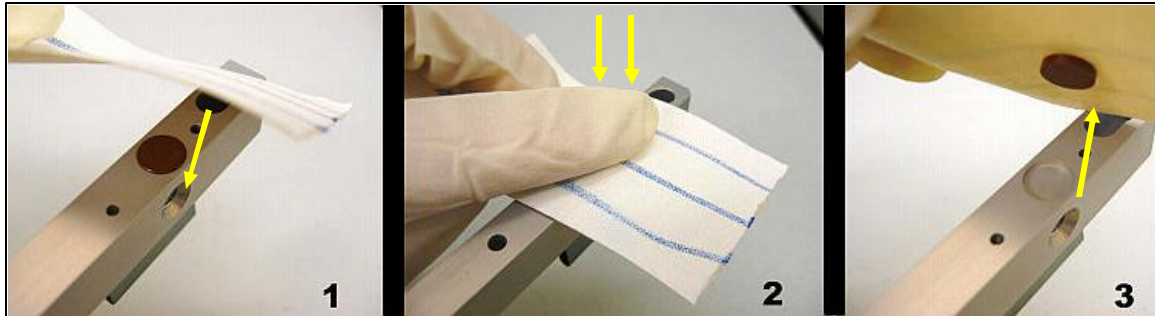

[Figure 5-H, Slide Pad Removal]

- 5.9 Thoroughly clean all parts using 100% IPA, cleanroom swabs and cleanroom wipes. Parts may be very dirty. See Figure 5-I for examples. A DI rinse and wipe is recommended to remove the IPA residue. Use clean dry disposable cleanroom wipes to remove excess DI water.



[Figure 5-I, Examples of high-cycle Holder and Roller wear]

Section 6 Re-assembling the Gate Assembly

 **NOTE**

Each bolt in the Gate Assembly has a specific torque value.
 Refer to the small torque table at each location for the
 specific torque on each bolt.

- 6.1 Align the Gate Stopper in the center of its recess on the Gate plate, and pushed all the way in towards the center of the Gate, and torque the Gate Stopper assembly bolts.

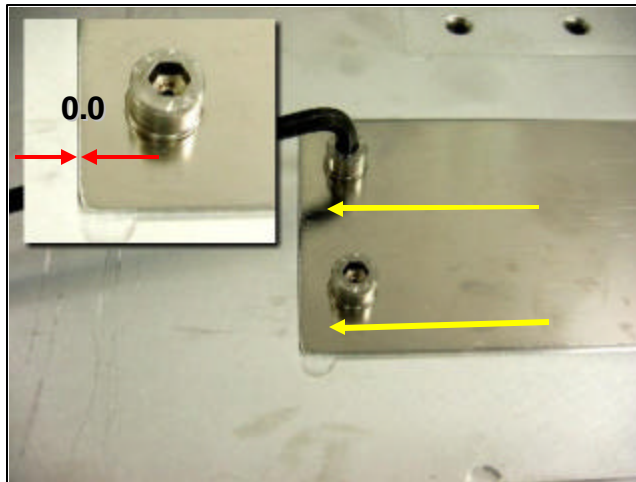

350 Valve	250 Valve	200 Valve
50 in-lb.	25 in-lb.	15 in-lb.

[Figure 6-A, Align and install the Gate Stopper]

- 6.2 Apply one bead of Krytox® 240AC to the inside of each Counter Plate Roller slot, Holder Roller slot, and Gate Supporter Roller slot. Spread evenly inside the Roller slots with a cleanroom swab. Use a clean swab or wipe to remove any excess grease that migrates out of the Roller slots.

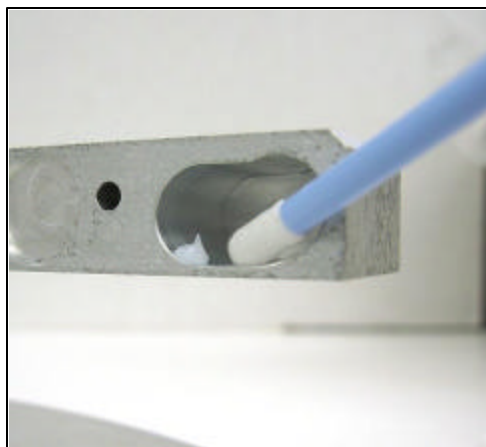

[Figure 6-B, Apply 1 bead of Krytox 240AC to each track]

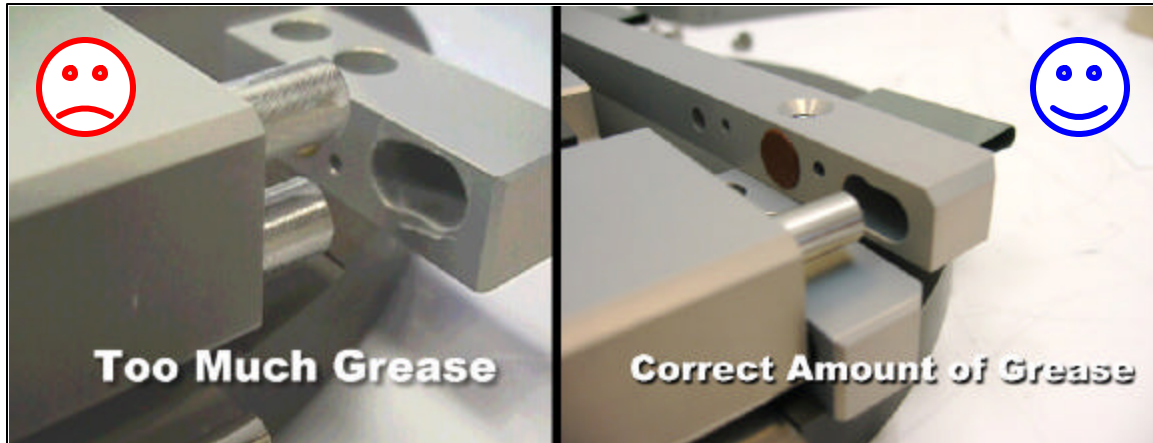

[Figure 6-C, Inspecting Grease Application]

- 6.3 Change Gloves. Clean off the Gate Plate with cleanroom wipes and swabs, using DI or IPA to remove all fingerprints and residue from the recesses of the plate.
- 6.4 Inspect each holder recess (boss) for damage. Look for damage on the edges of the boss from improper handling or metal tools. Replace the Gate Plate if damage is found.

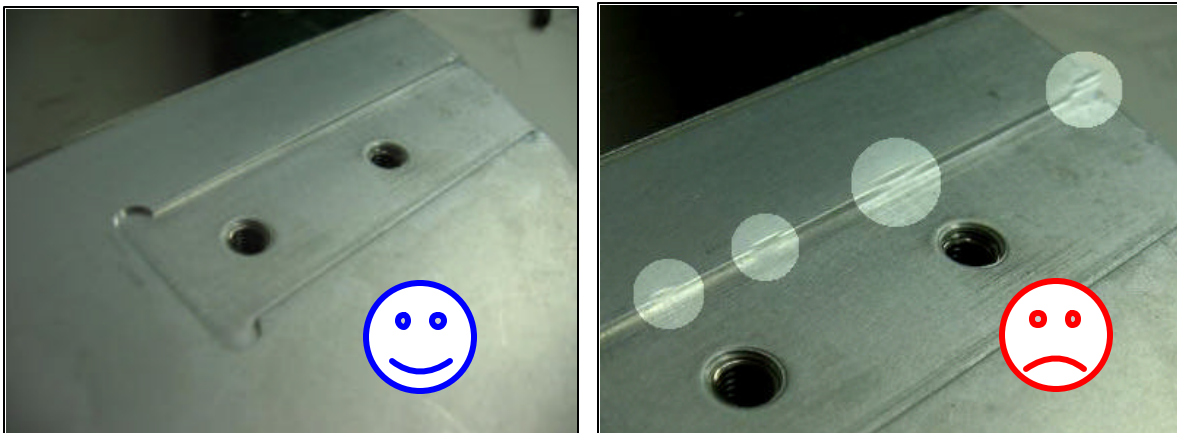

[Figure 6-D, Inspecting the Holder recesses]

- 6.5 Gently place the Gate Support on the Gate plate, taking note of the recessed holes for the gate Stopper Bolts.

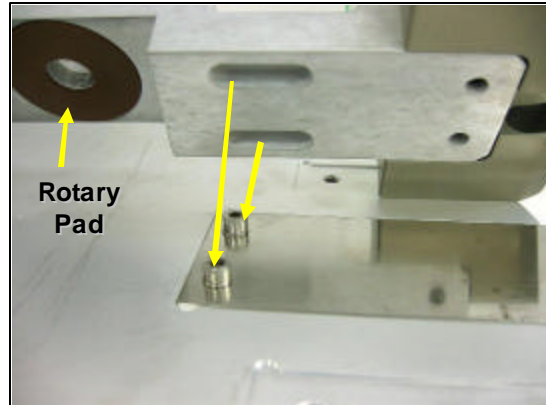

[Figure 6-E, Gate Support Recesses]

- 6.3 Apply 1 bead of Krytox® 240AC to each of the Rollers. With a gloved hand, spread the grease evenly over the entire shaft and the tips of the Rollers. The coating should be a uniform, nearly invisible sheen, rather than a “coat” of grease. Refer to Figure 6-C for the proper grease amount.



[Figure 6-F, Add 1 bead of grease to each Holder and spread evenly]

- 6.4 Slide the greased Rollers through the bottom holes of the Gate Supporter, through the protect pipes, and all the way in to the Holders. Do not force the Rollers in. They should slide easily. If there is resistance, inspect tracks and rollers for damage. Replace as needed. Never use sandpaper or abrasives to clean or smooth rollers.

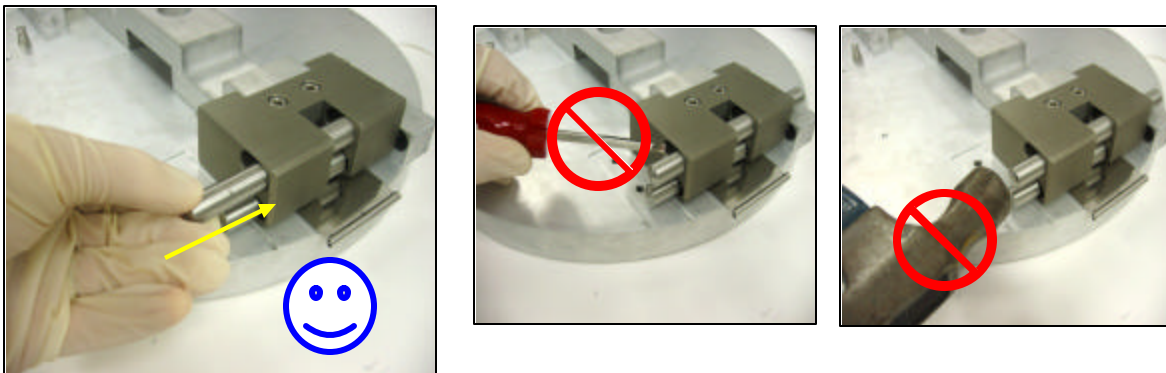

[Figure 6-G, Rollers slide in easily. Never use tools to force rollers in]

- 6.5 With a swab, remove any grease that scrapes off the Rollers onto the outer edges of the Roller slots or Protect Pipes.



[Figure 6-H, Clean off any excess grease with a swab]

- 6.6 Add a drop of DI water to each Slide Pad recess, and install the slide pads in the Holders, round side out. Wipe off any excess DI Water.

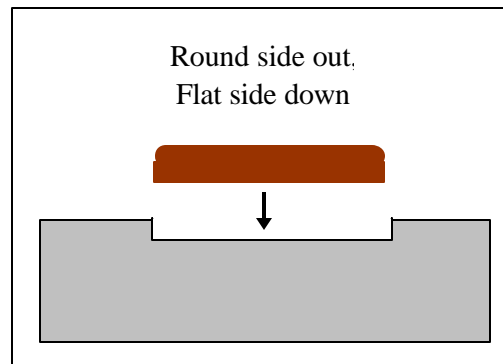

[Figure 6-I, Add a drop of DI water and install the Slide Pads]

 **NOTE**

Remember the Slide Pad orientation, the rounded side should be facing out. On newer valves the Slide Pads are rounded on *both* sides, eliminating the flat side.

- 6.7 Re-install the Holders in their recessed spaces. Each Holder works in only one location. The kidney bean-shaped tracks in the Holders slope UP towards the Gate Stopper (see Figure 6-J).

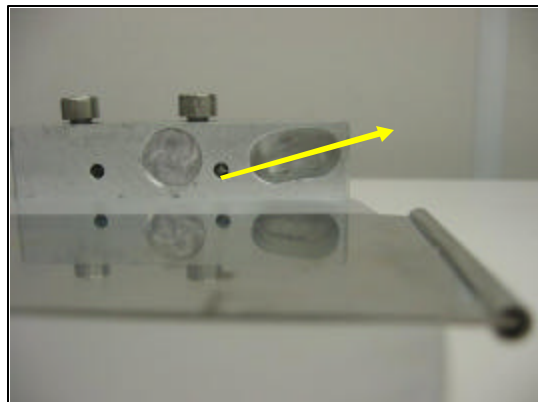

[Figure 6-J, All Holder tracks slope UP towards Gate Stopper]

! CAUTION !

Alignment of the Holders is the most important step in the rebuild procedure. If the Holders are not aligned correctly, the Gate Assembly can jam, causing major problems. If there is binding in step 6.10, re-align the Holders. If binding cannot be removed, replace ALL of the holders and rollers.

- 6.8 Align the Holders: Squeeze the two Holders closest to the Gate Supporter towards each other, and at the same time towards the center of the gate. Hold, and tighten the Holder bolts. It may help to have one person to tighten, while one keeps the Holders in place.

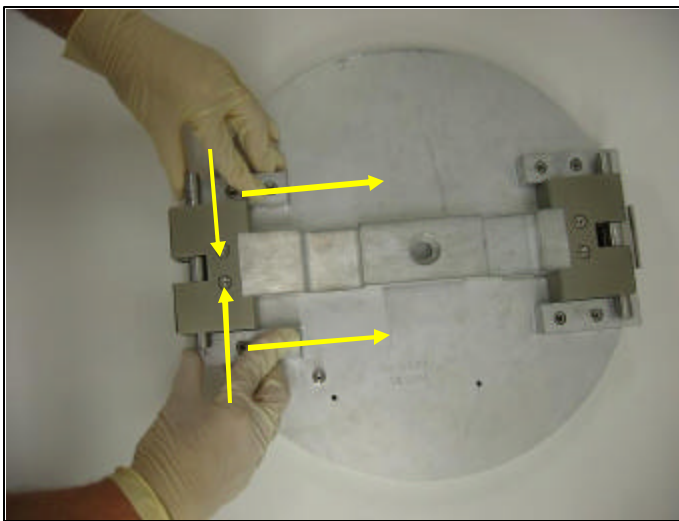

350 Valve	250 Valve	200 Valve
70 in-lb.	50 in-lb.	30 in-lb.

[Figure 6-K. Alignment of Holders]

- 6.9 Do the same for the other two Holders. Push together and towards the center of the plate, holding them in place while they are tightened to the specification above. It may help to have one person hold, while the other person tightens the bolts.
- 6.10 Check the Holders for correct alignment by pushing down on the Gate Supporter and rocking the Gate Assembly Back & Forth, as in Fig 6-L. There should be no binding in its movement. If there is binding in the movement, re-align the holders. If binding cannot be removed, inspect the tracks and rollers and re-align or replace parts as necessary.

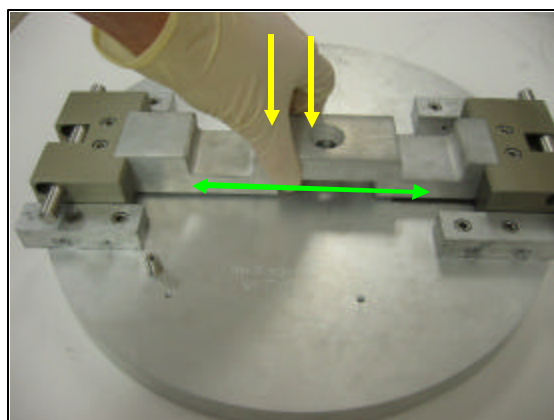

[Figure 6-L. Alignment of Holders]

- 6.11 Install the remaining 2 Rollers. Wipe off any excess grease near the roller slots and do not force Rollers into Holders.
- 6.12 Add The Counter Plates. The Counter Plate tracks slope DOWN towards the Gate Stopper. Ensure that they are installed parallel, not diagonal.

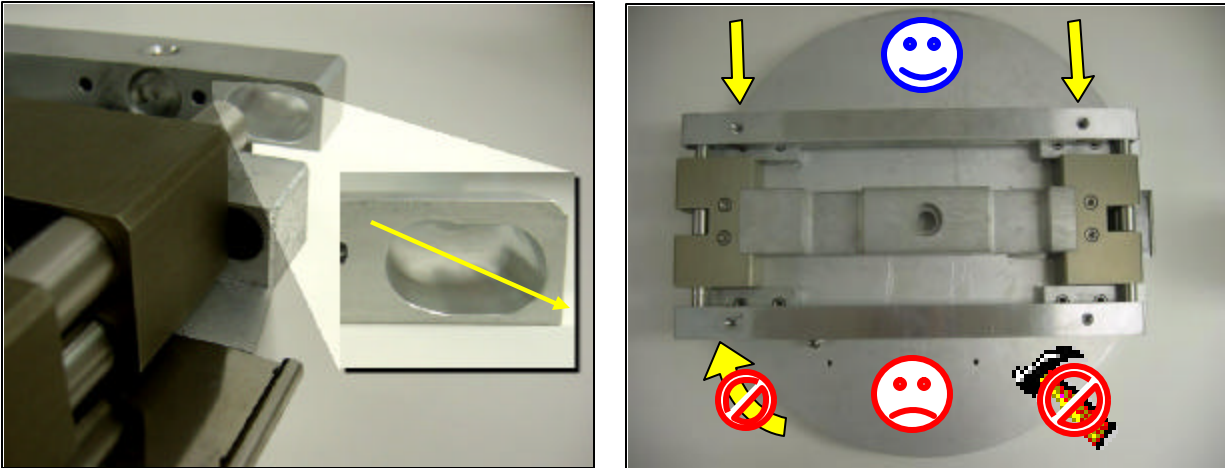

[Figure 6-M. Counter Plate Slope and Installation]

- 6.13 Install the Connecting Bars between the Counter Plates using the Connecting Bar bolts & split washers, but do not tighten.
- 6.14 Align the Counter Plates by pushing the Counter Plates to one end of their track, while lightly tightening Connecting Bar bolts. This ensures the counter plates are at the end of their travel in the tracks, and that they are aligned together.

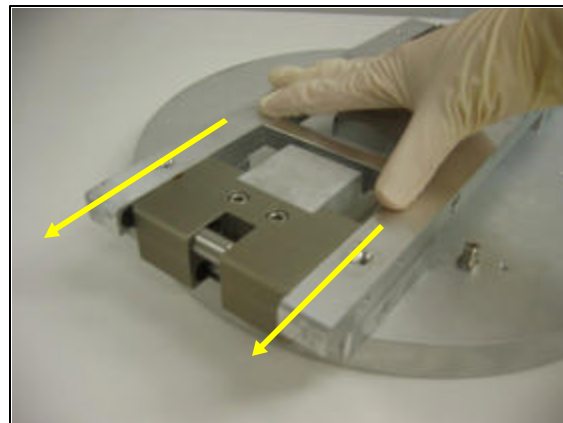

[Figure 6-N. Align the Counter Plates]

- 6.16 Tighten all four Connecting Bar bolts, and insure that the Connecting Bars do not twist. They should be parallel with the upper surface of the Counter Plates. Torque the Connecting Bar bolts to the proper torque.

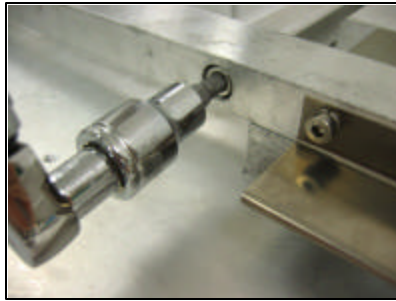

350 Valve	250 Valve	200 Valve
70 in-lb.	50 in-lb.	30 in-lb.

[Figure 6-O, Ensure the Connecting Bars do not twist, then Torque]

- 6.17 Install all 4 Plate Springs on the Counter Plates and Holders. Torque the Plate Spring bolts with a Torque Wrench.

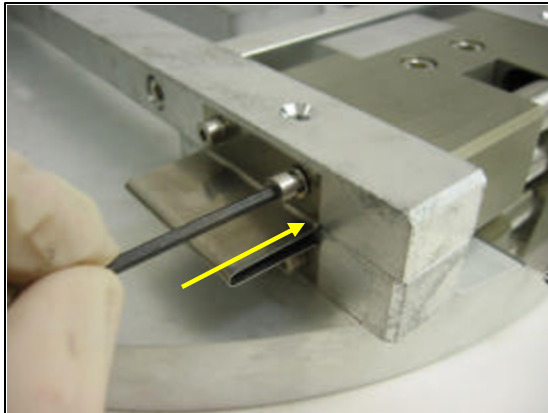

350 Valve	250 Valve	200 Valve
20 in-lb.	15 in-lb.	15 in-lb.

[Figure 6-P, Install the Plate Spring Bolts]

- 6.18 When assembled, the Counter Plates and Holders will align with the ends all even, as shown in the picture below. A slight offset is acceptable. A slight vertical gap also exists between them.

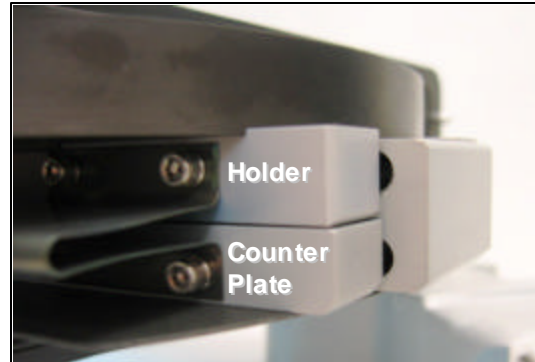

[Figure 6-Q, Correctly Assembled Counter Plates]
Note how counter plate and holder ends line up flush.

- 6.19 When completely assembled, check the assembly for easy movement as in Fig 6-R by rocking the Gate Supporter and Rollers through the full range within the roller slots. The movement must be smooth through its travel. If binding occurs, remove all 4 Plate Springs, loosen both connecting bars, and realign the Counter Plates. Re-torque and test again. If binding cannot be removed, replace all the Holders, Counter Plates, Rollers and the Gate Supporter.

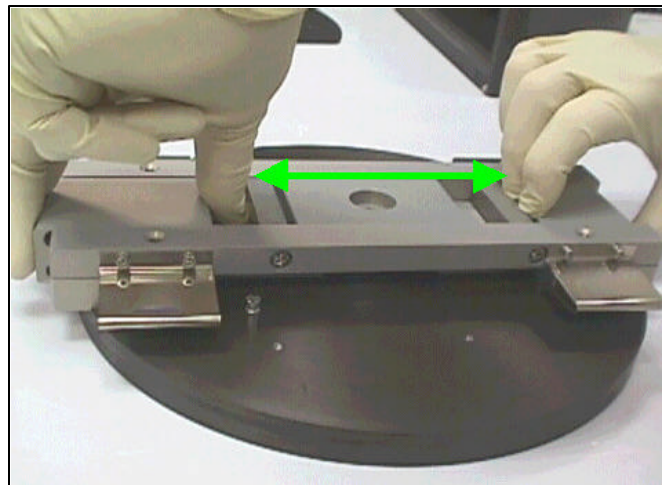

[Figure 6-R, No binding is permissible]

- 6.20 Wipe down entire assembly with IPA and a cleanroom wipe, followed by a DI wipe, to remove stray fingerprints.

- 6.21 Install the Touch Plate and torque the Touch Plate flat head screws. The hole in the center of the Touch Plate lines up over the hole in the Gate Supporter. It will only work one way. Inspect the Touch Plate for scratches or bending

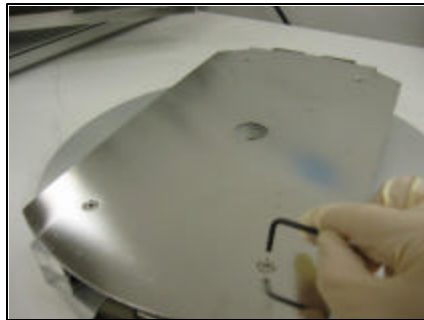
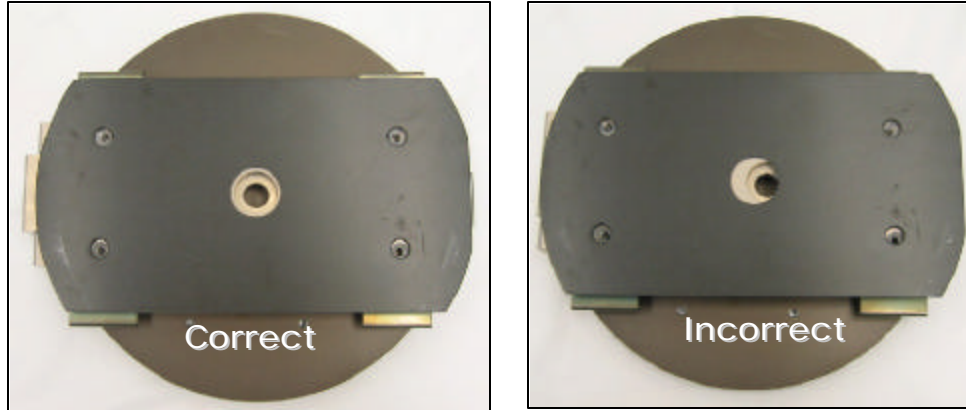

350 Valve	250 Valve	200 Valve
30 in-lb.	30 in-lb.	30 in-lb.

[Figure 6-S, Correct Touch Plate installation]

- 6.22 Check for warping of the Touch Plate after install. It should lie flat on the Counter Plates. (See Figure 6-T) If there is warping, try loosening the Touch Plate flat-head screws, and re-torquing them evenly in a quad-pattern, each a little at a time until they all reach 30 in-lb. If the Touch Plate will not lie flat, replace it with a new Touch Plate.

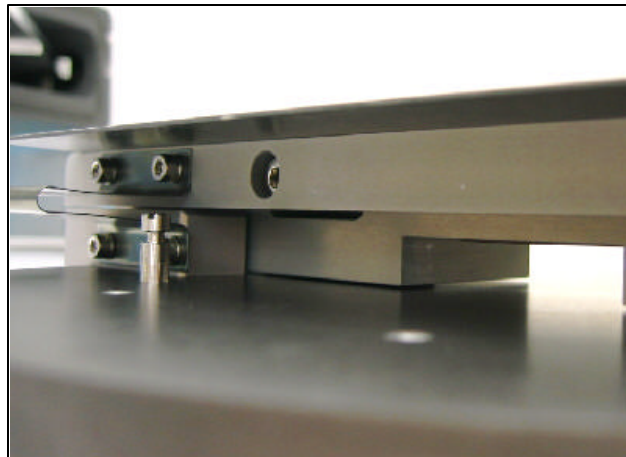

[Figure 6-T, Touch Plate lies flat on counter plates]

Section 7

O-ring Removal and Installation

The Pendulum Gate Valve line has many different o-ring sizes, compounds and cross-sections. The correct o-ring must be installed properly, or else it will leak.

NOTE

NO Grease should be applied for o-ring installation.

- 7.1 Remove the old o-ring with an o-ring pick. Never use a metallic tool or screwdriver. Use DI water as a lubricant if necessary. Thoroughly clean the groove with IPA and a wipe.

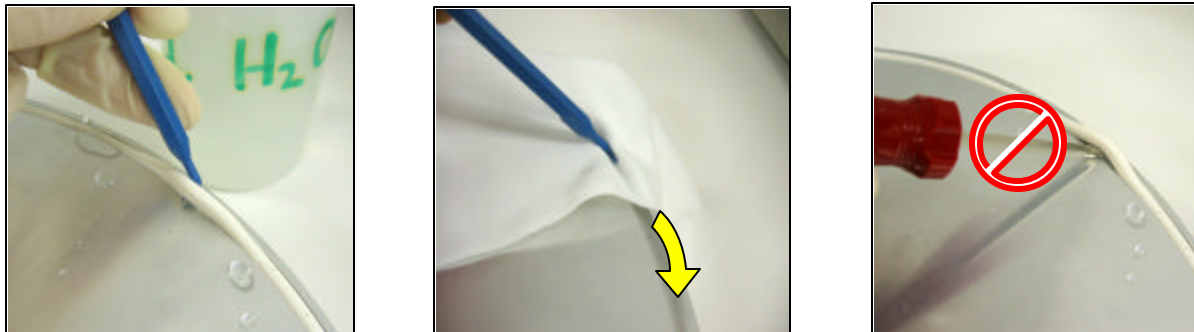

[Figure 7-A Removing the O-ring, and cleaning the groove]

For D-shaped, or “teardrop” cross-section o-rings, skip to Step 7.4

Round O-rings

- 7.2 Using DI water as a lubricant, partially fill the groove with DI, place the new o-ring on the groove, and press it down in the groove with your thumbs at the 4 vent holes.
- 7.3 Once the first 4 points are seated, press the o-ring into the groove at points 180° apart, going around the rest of the o-ring, seating it. Use as much DI as needed to facilitate installation.

D-Seal or “teardrop” shaped o-rings

- 7.4 For the teardrop cross-section o-ring, a different method works best. Note that the point of the o-ring goes towards the center of the Gate, and the flat side goes down in the groove. **Review the training video for a detailed demonstration.**
- 7.5 Using DI water as a lubricant, partially fill the groove with DI, place the new o-ring on the groove, and press it down in the groove with your thumb at one of the vent holes.
- 7.6 Next, stretch the O-ring to reduce its cross-section, and roll it into the groove.
- 7.7 Push-back the O-ring to relieve the stretch, then press, stretch and roll again continuing around the gate.
- 7.8 Continue to push back the O-ring, so that the last section needs to be stretched to get in the groove. The D-Seal will feel slightly loose in its groove.
- 7.9 Ensure that there are no twists or bumps in the o-ring after the o-ring is seated. Unlike a round o-ring, a D-shaped o-ring will feel loose in the groove when completely installed.
- 7.10 Blow out the leftover DI by forcing CDA or Nitrogen into the 4 vent holes. Make sure you’re wearing goggles, as DI will spray out from the other vent holes. Repeat on all 4 vent holes until no DI comes out.
- 7.11 Move the completed Gate Assembly to a safe area while servicing the rest of the valve.

Section 8

Actuator and Gate Arm Shaft Removal

Required Shaft cleaning and rebuilding (Preventive Maintenance) Kit
 (Required at each Shaft PM interval)

Seal Kit

VTEX 250mm Seal Kit	3870-03587
VTEX 350mm Seal Kit	3870-03698

N-C 200mm Seal Kit	3870-04176
N-C 250mm Seal Kit	3870-03682
N-C 350mm Seal Kit	3870-03698

Recommended Shaft refurbishing and parts replacement kits
 (Replace on failure, or as needed per inspection to prevent failure)

Case Kit

VTEX 250mm Case Kit	3870-03591
VTEX 350mm Case Kit	3870-03577

N-C 200mm Case Kit	3870-04182
N-C 250mm Case Kit	3870-03687
N-C 350mm Case Kit	3870-03605

Air Solenoid Kit

VTEX 250mm Air Solenoid Kit	3870-03594
VTEX 350mm Air Solenoid Kit	3870-03580

N-C 250mm Air Solenoid Kit	3870-03690
N-C 350mm Air Solenoid Kit	3870-03608

Open Close Sensors

VTEX 250mm Open/Close Sensors	3870-03598
VTEX 350mm Open/Close Sensors	3870-03584

N-C 250mm IPV Open/Close Sensors	3870-03694
N-C 350mm IPV Open/Close Sensors	3870-04685

N-C 200mm TPV Closed Sensor	3870-04187
N-C 250mm TPV Closed Sensor	3870-04187

For Pneumatic Isolation Valves, skip to section 8.5



Remove all power to the valve motor and controller before opening the case cover.

Removing a rotary flag sensor (for a linear sensor, skip to Step 8.4)

8.1 Remove the five Phillips screws from Actuator cover to access pivot shaft (Fig. 8-A)

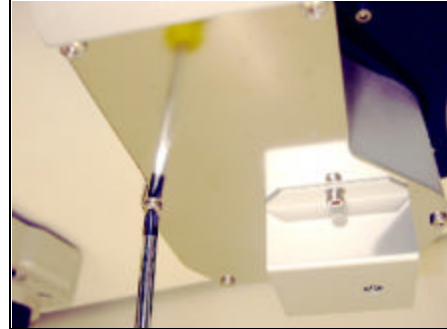
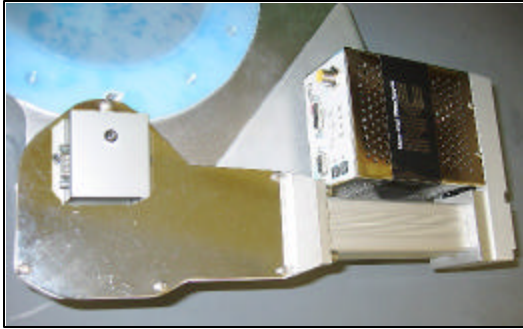

[Figure 8-A, Throttling Gate Valve Actuator and cover screws]

8.2 Carefully rotate the case cover to remove the sensor assembly from the path of the flags, and slowly lift off case cover. Do not force it off – you could break the plastic flags.

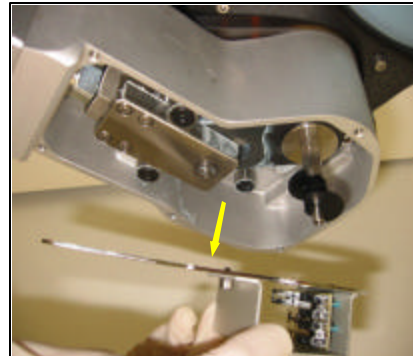
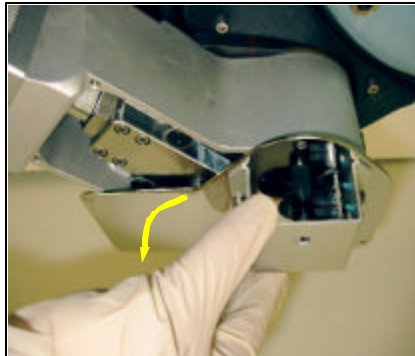

[Figure 8-B, Carefully twist and remove the cover]

8.3 Remove the “Flag Pole” by unscrewing it with the Nor-Cal “Super Wrench”



[Figure 8-C, Unscrew the “Flag Pole” with the Nor-Cal “Super Wrench”]

- 8.4 Removing a Linear Sensor: For a linear sensor, remove the 4 bolts holding the linear sensor to the Case cover (1), then remove the 5 Phillips screws holding the Case cover (2).

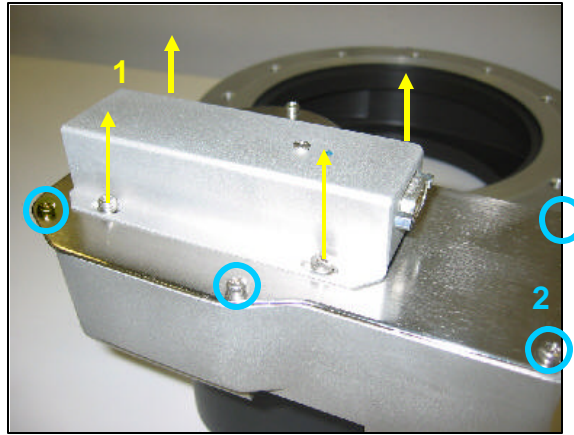

[Figure 8-D, Remove the Linear Sensor]

- 8.5 Removing the Case on a Pneumatic Isolation valve requires removing the air lines and Air Control Bracket, then removing the five Phillips screws in the Case cover.

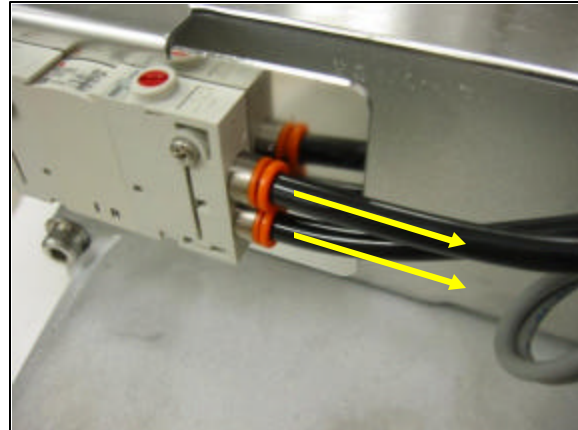
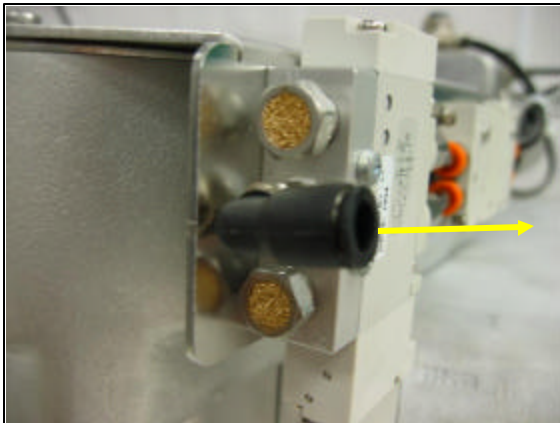

[Figure 8-E, Remove the air lines]

 **NOTE**

During handling of the Actuator, it is highly recommended to wear double set of gloves, as the lubrication grease tends to spread easily.

 **NOTE**

To prevent cross-contamination of Multemp FFRM grease with vacuum grease, do not use the same set of tools to remove the actuator assembly and gate arm shaft as was used to remove and disassemble the gate, or clean them thoroughly before use.

 **NOTE**

Be sure to keep hardened Loctite particles from getting onto the grease in the case. Promptly remove any particles that may fall onto grease.

- 8.6 Loosen the two Crank Arm set screws holding the Crank Arm to the shaft, using the access hole on the side of the case. In V-Text valves there is no access hole, and a modified Allen Wrench is required to loosen the set screws.

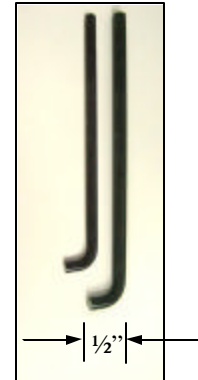
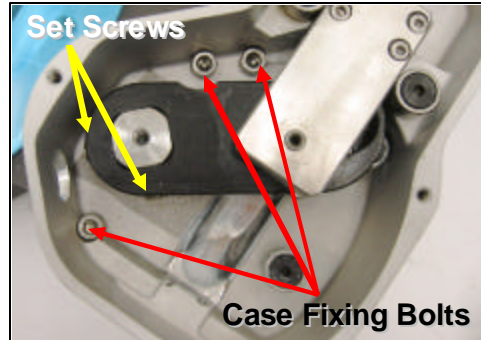
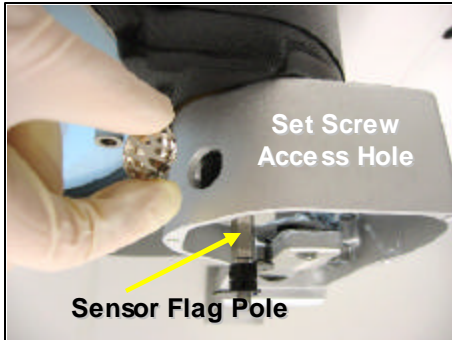

[Figure 8-F, Crank Arm Hex Bolt, Set Screws and Case Fixing Bolts]

- 8.7 Remove the three Actuator (Case fixing) bolts holding Actuator to the Gate Valve body (Figure 8-F)

! CAUTION !

Step 8.8 may require 2 individuals. Support actuator when removing the hex bolts. The actuator will tend to drop due to its weight. Remove the guide pin in the body, and be careful not to lose it.

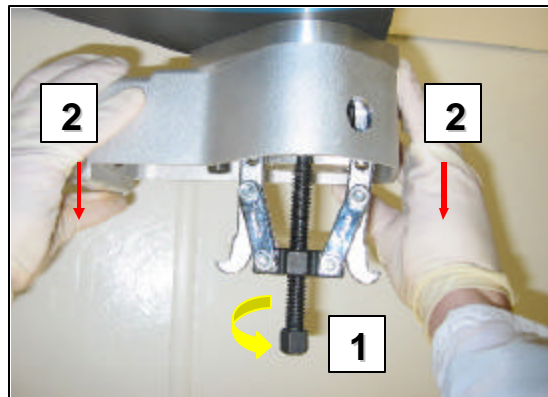

[Figure 8-G, Actuator Removal]

- 8.8 Remove the Case by pulling on both the Crank Arm and case at the same rate, keeping them parallel. The Nor-Cal crank arm puller helps to remove the Crank Arm from the shaft. I.E. turn the puller a little [1], then lift the case off a little [2], and repeat until removed. Be careful not to spread the grease around.

- 8.9 Remove exposed bearing from shaft and place on a wipe.

NOTE

If the bearing is not on the shaft, it is most likely still encased inside the housing. The bearing must come off the shaft straight or it can jam on the shaft. Never use a hammer to remove the bearing.



[Figure 8-H, Bearing Removal]

- 8.10 Change gloves to prevent grease migration into vacuum area.
8.11 Loosen the Gate Arm bolt clamping the Gate Arm to the shaft (Fig. 8-I).

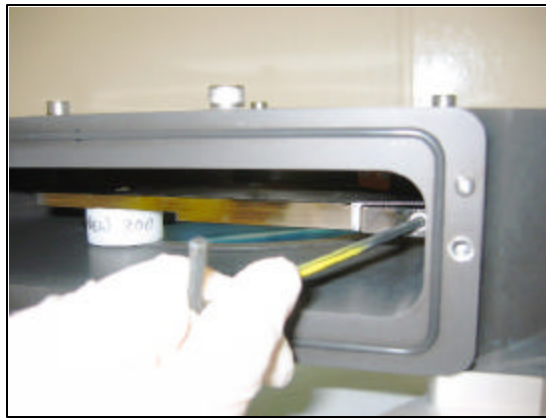

[Figure 8-I, Loosening the Gate Arm Bolt]

- 8.12 Remove four Shaft Guide Housing bolts from Shaft Guide Housing (underneath case) and remove assembly.

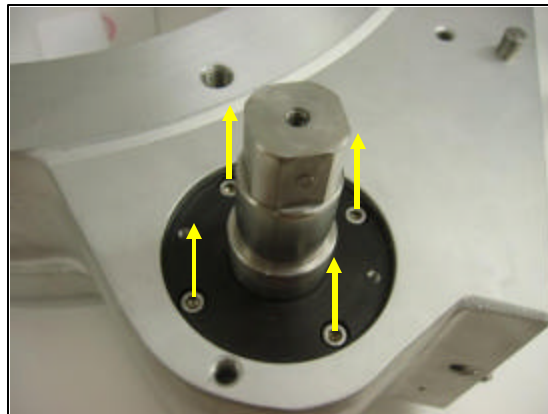

[Figure 8-J, Shaft Guide Housing]

 **NOTE**

If the guide is difficult to remove, use the hex screws as handles by threading them into the two threaded holes on the guide seal assembly. See Figure 8-K below.

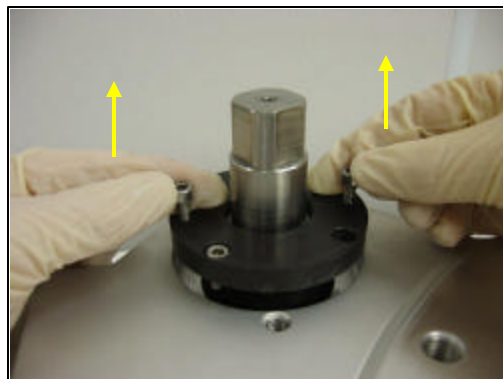

[Figure 8-K, Use 2 bolts as handles to pull up the o-ring guide]

- 8.13 Pull out the shaft and place it on a wipe. In 350 valves you may need to use a screwdriver as a lever to open the gate arm clamp. (See Figure 8-L)

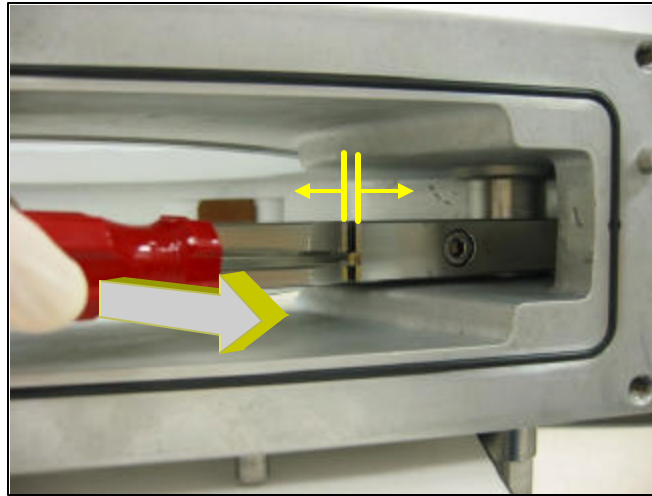

[Figure 8-L, Use a screwdriver as a lever to help open the 350 gate arm clamp]

 **NOTE**

The Shaft key may come loose from shaft, *DO NOT* lose the key!

- 8.14 From the other side of the valve, remove the four Bearing Flange bolts from the Bearing Flange and remove assembly including bearing, wavy washer and Shaft Guide Housing (top).

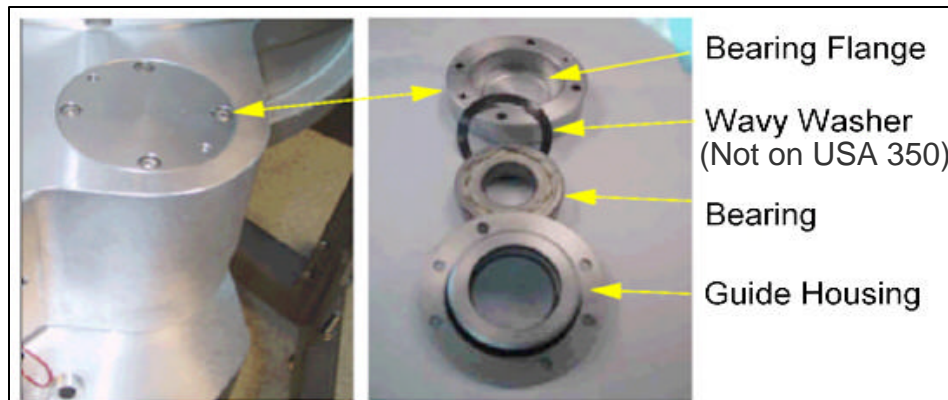

[Figure 8-M, Bearing Flange Stackup]

- 8.15 Remove three O-rings from each Shaft Guide Housing using a plastic o-ring pick.
 8.16 Clean all parts thoroughly using 100% IPA and disposable cleanroom wipes. *DO NOT USE PRESATURATED WIPES.*
 8.17 Clean all grease from o-rings and Shaft Guide Housing using 100% IPA and disposable cleanroom wipes. *DO NOT USE PRESATURATED WIPES.*



Do not get FFRM or Lubriplate grease inside the valve body or on the gate assembly. It is not vacuum-safe grease.

8.18 NOTE: Perform this procedure for both sides of each bearing:
 With a cleanroom wipe, wipe excess grease from both bearings removed earlier. Using your finger, apply the FFRM or Lubriplate grease to the bearing until the lubricant is worked in between the bearings, leaving the race visible as shown.

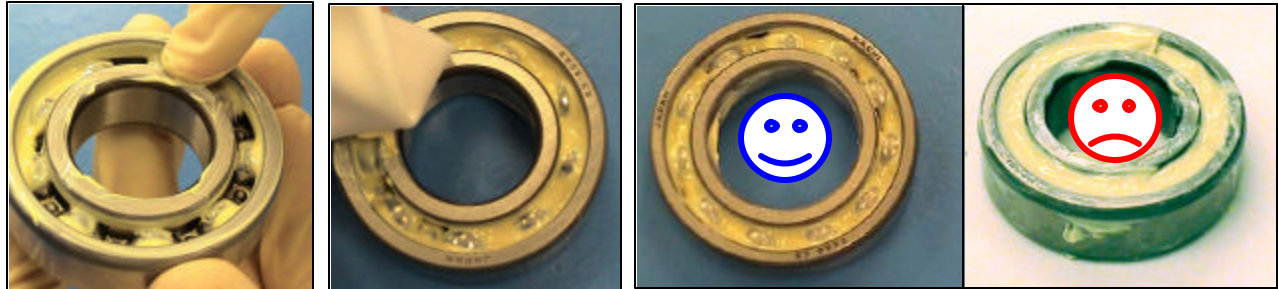

Add Grease to bearing

Wipe off excess

Correct Amount

Too much grease!

[Figure 8-N, add grease to Bearings and wipe down]

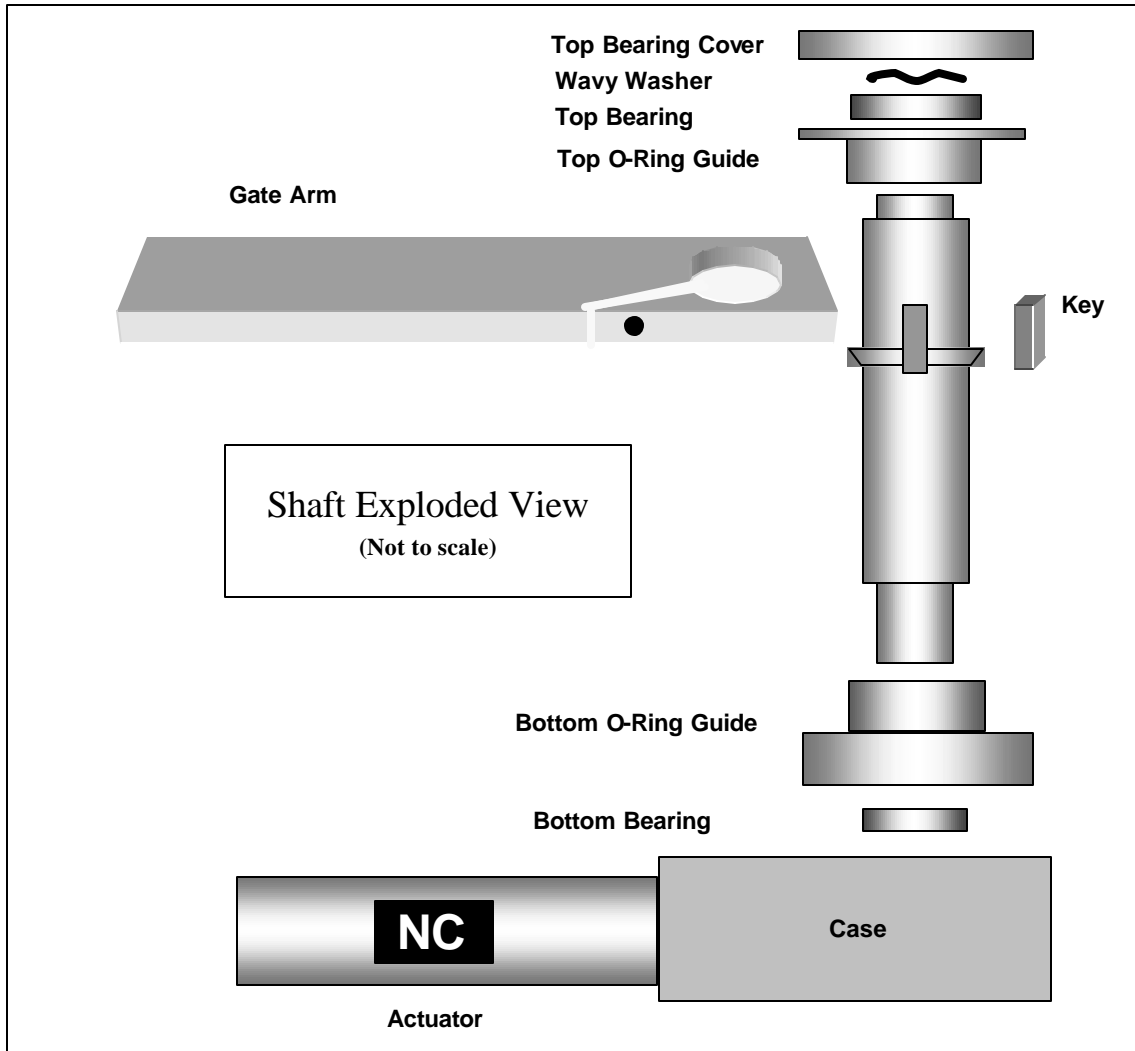

Section 9 Re Assembly of the Shaft

NOTE

Viton o-rings have a dull black finish or brown, Kalrez o-rings are shiny black. You cannot tell the difference between black Kalrez and black Viton after the seals have been greased.

NOTE

Do not cross-contaminate one vacuum grease with another vacuum grease or with the Multemp FFRM grease. If cross contamination inadvertently occurs, clean all contaminated parts thoroughly, and re-apply the appropriate grease.

NOTE

Prior to reassembling the Gate Valve, wet-clean the interior of the gate housing using 100% IPA, or DI water. Use a dry wipe to remove DI.

- 9.1 Ensure all parts are clean and change gloves as necessary.



- 9.2 Add 2 beads of Krytox LVP to each track in the o-ring guide. Distribute it evenly in each track with a cleanroom swab.
- 9.3 Coat each of the Shaft Seal o-rings of the Shaft Guide Housing (top) with Krytox LVP, working the grease into the o-ring for at least one minute each.
- 9.4 Wipe off excess, and then add 1 bead of grease, lightly spreading a light coating on the o-ring.
- 9.5 Install each o-ring inside the Shaft Guide Housing. Install Guide o-ring on Shaft Guide Housing. O-ring configuration may vary by process type.

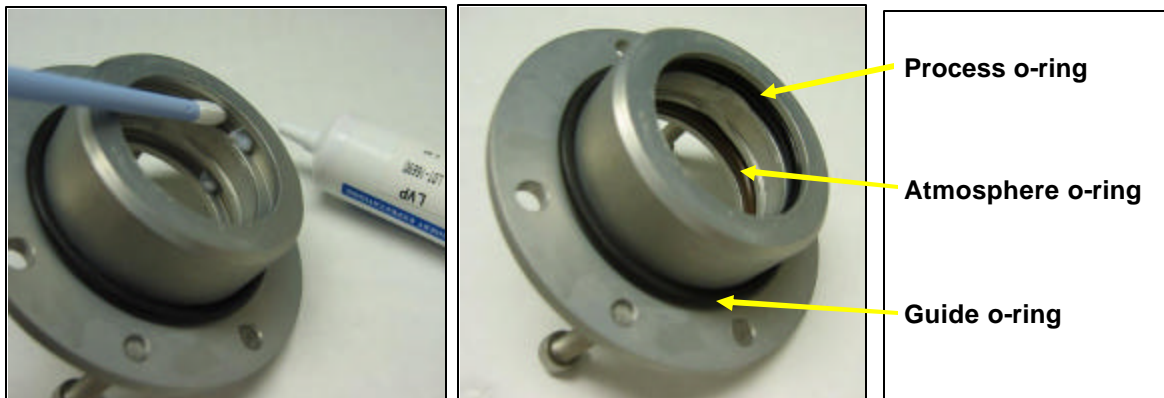

[Figure 9-A, Greasing the tracks, and the O-ring Locations]

- 9.6 Repeat steps 9.1 – 9.5 to reassemble the bottom Shaft Guide Housing.

- 9.7 Apply ¼ bead of Krytox® LVP on the shaft, at the top & bottom lip. This helps the o-rings slide over the shaft.
- 9.8 Install the top Shaft Guide Housing into the Gate Valve body. Align the 4 holes of the Shaft Guide Housing with the threaded holes of the Gate Valve housing.

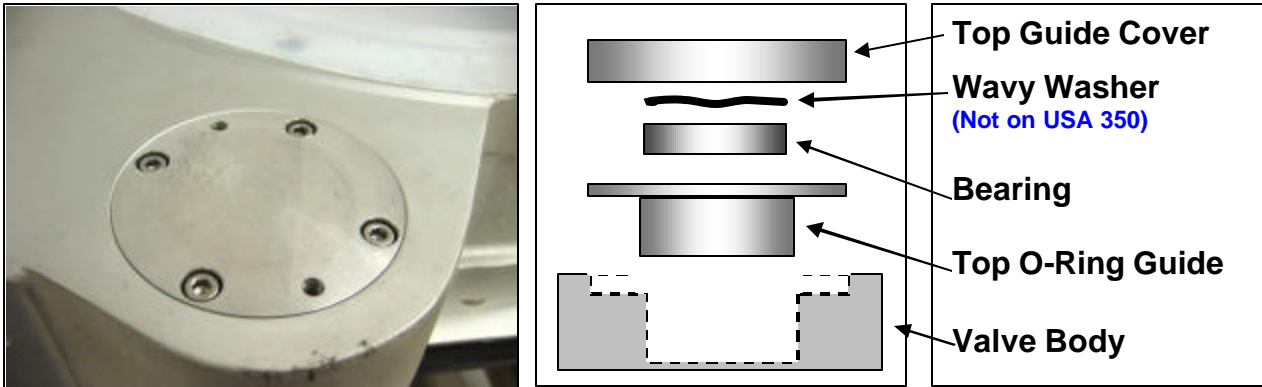

[Figure 9-B, install the o-ring guide]

- 9.9 Center the bearing, wavy washer and bearing flange over the top of the Shaft Guide. Secure the Bearing Flange with the four long Bearing Flange bolts with split washers, and torque down according to the chart below.

350 Valve	250 Valve	200 Valve
65 in-lb.	35 in-lb.	35 in-lb.

 **NOTE**

The Nor-Cal 350 does not have a wavy washer.

- 9.10 Place gate arm in housing with clamping bolt facing out and insert shaft through housing and gate arm. Align the key on the shaft with the notch in the gate arm. For the 350 valve you may need a screwdriver to help open the gate arm clamp.

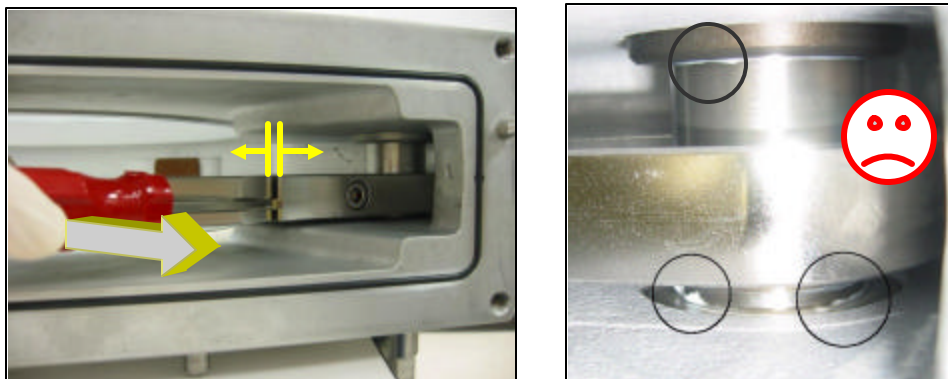

[Figure 9-C, install the Gate Arm (bolt out) and the Shaft. Check for Grease]

- 9.11 Wipe off all excess grease on the shaft, even on the back side that can't be seen.

- 9.12 Slide gate arm up and down on the shaft, until it rests approximately 1-2 mm above the shoulder. *Lightly* tighten the Gate Arm clamping bolt at this time.
- 9.13 Install the bottom Shaft Guide (see Figure 9-D). You may need to push the shaft into the body or support the Gate Arm to center the shaft in the o-ring Guide. Secure the assembly using the four short Shaft Guide Housing bolts with split washers.

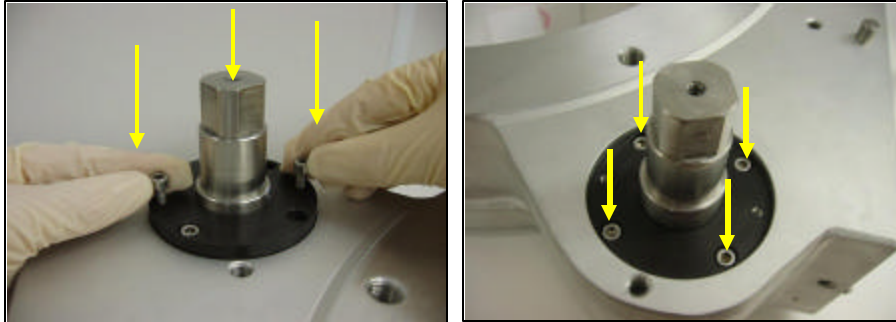

350 Valve	250 Valve	200 Valve
65 in-lb.	35 in-lb.	35 in-lb.

[Figure 9-D, Install the Bottom O-Ring Guide]

- 9.14 Install the bearing onto the Shaft. It must go on straight or it will jam. Never use a hammer to install this bearing.



[Figure 9-E, Install the Bearing straight on the Shaft]

- 9.15 Place the Gate arm in the center of the bore of the valve, and mount the actuator assembly back on Gate Valve housing. Align the square of the shaft with crank arm, and rotate the Actuator until it aligns with the guide pin on the Gate Valve housing.

Make sure the case lies flat against the valve body. Install the Case fixing bolts and flat washers, and Torque the Case Fixing Bolts according to the chart below

350 Valve	250 Valve	200 Valve
160 in-lb.	130 in-lb.	130 in-lb.

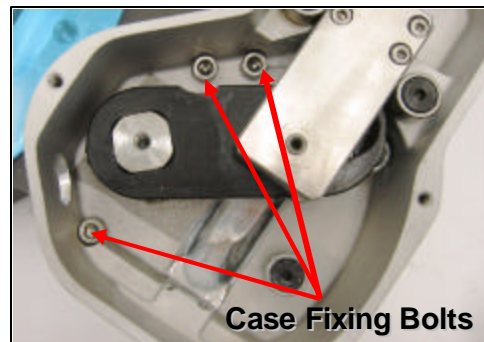

[Figure 9-F, Case Fixing Bolts]

- 9.16 Apply Loctite on the Crank Arm bolt (or “Flag Pole”) and install with the cover washer on the end of the shaft over the Crank Arm. Torque a Stainless hex-head bolt to 75 in-lb., and use 65 for the sensor flag pole.

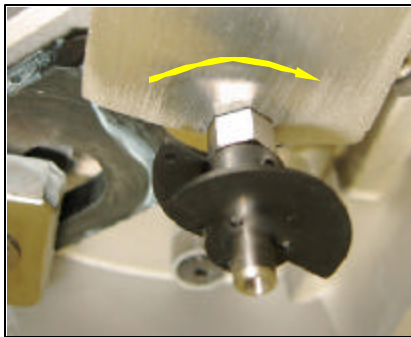

Flag Pole

65 in-lb.



Hex Bolt

75 in-lb.

- 9.17 Unscrew, apply Loctite and re-tighten the two Crank Arm set screws on the crank arm to the shaft. Rotate the Gate Arm back and forth to access backside set screw. Torque the set screws to 100 in-lb (all sizes.)
- 9.18 Replace the Case Cover and clean all tools with IPA to prevent grease contamination.

 **NOTE**

During handling of the Actuator it is highly recommended to change gloves often, as the crankcase lubrication grease tends to spread easily.



Do not get FFRM or Lubriplate grease inside the valve body or on the gate assembly. It is not vacuum-safe grease.

 **NOTE**

Be sure to keep hardened Loctite particles from getting onto the grease in the case. Promptly remove any particles that may fall onto grease.

Section 10 Gate Arm Height Adjustment

200mm Gate Arm Height Gauge	250mm Gate Arm Height Gauge	350mm Gate Arm Height Gauge
No AMAT P/N assigned yet	3870-03560	3870-03561
All of the above gauges are included in the Nor-Cal Tool Kit: 3870-03699		

Align and tighten Gate Arm per the following procedure. This is the Best Known Method (BKM) to correctly adjust the Gate Arm height. *Do not use any other methods used in the past.*

NOTE

It is important to understand that the Gate Arm Height Gauge is not a tool to *set* the height, but a Gauge to *measure* the height you set.

- 10.1 Raise/lower the Gate Arm until it is approximately 1mm above the lip on the shaft, then *lightly tighten* the Gate Arm bolt. 1mm is a good starting point. (Figure 10-A)
- 10.2 Hand-tighten the correct Height Adjustment Gauge on to the Gate Arm (Figure 10-B)

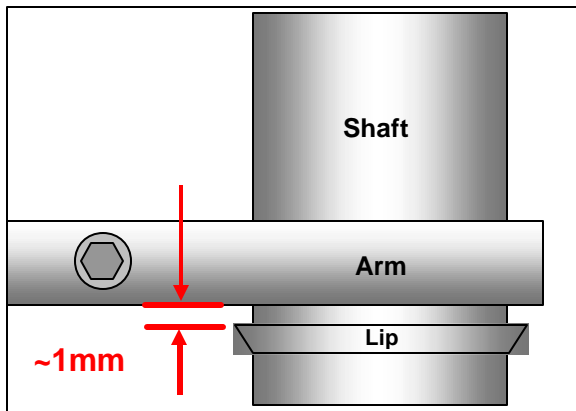

[Figure 10-A, Initially adjust the Gate Arm to 1mm above the lip on the Shaft]

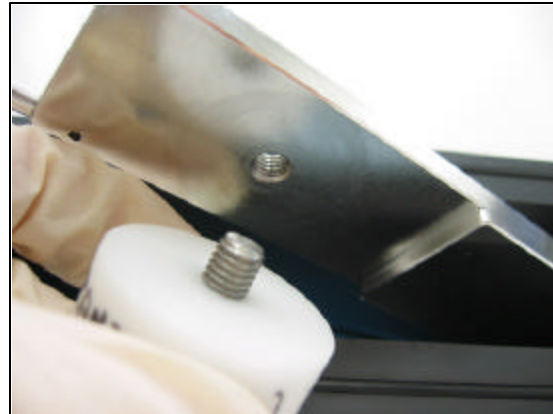

[Figure 10-B, Install the Height Adjustment Gauge on the Gate Arm]

- 10.3 Rotate the Gate Arm until the height adjustment tool is above the inner raised/machined surface of the Gate Valve housing, and inspect the gap between the gauge and the lip.

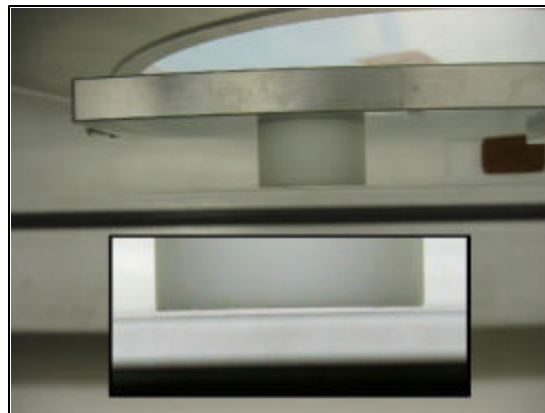

[Figure 10-C, Inspect the gap between the Gauge and the inner flange]

- 10.4 If the Gate Arm Height Gauge touches the lip of the flange, then the Gate Arm Height must be raised. If there is a gap between the gauge and the lip, slide 1 piece of cleanroom paper between the Gauge and the lip, to check for clearance.

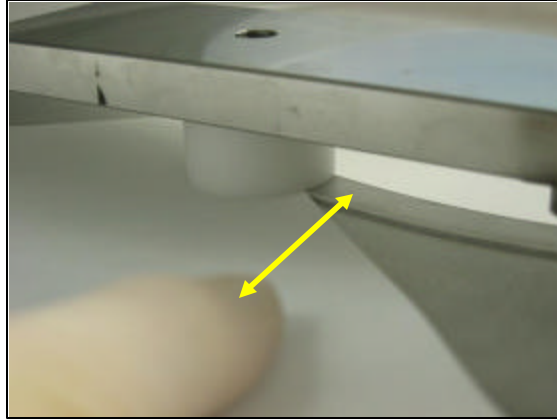

[Figure 10-D, To inspect the gap, slide 1 sheet of cleanroom paper between the Gauge and the inner flange]

- 10.5 Determine the height of the Gate Arm:
- 10.5.1 If the cleanroom paper does not fit between the Gauge and the lip, the Gate Arm is too low. Raise the gate arm slightly, and return to Step 10.3
- 10.5.2 If the cleanroom paper easily slides between the gauge and the lip with no resistance, then the Gate Arm is too high. Lower the gate arm slightly, and return to Step 10.3
- 10.5.3 If the paper slides between the gauge and the lip with some resistance, the Gate Arm Height is set correctly. Proceed to Step 10.6
- 10.6 When the height is set correctly, use a long-shank extension to torque the Gate Arm bolt. It is a good idea to re-check the height after torquing the bolt.



350 Valve	250 Valve	200 Valve
210 in-lb.	130 in-lb.	65 in-lb.

[Figure 10-E, Torque the Gate Arm Height Bolt]

- 10.7 Remove the Gate Arm Height Adjustment Gauge from the Gate Arm.

Section 11 Replacing the Hard Stop

Single Piece Hard Stops

Valve Size	VTEX	Nor-Cal
200mm	N/A	3870-04186
250mm	3870-03596	3870-03692
350mm	3870-03582	3870-03610

Multiple-piece Hard Stops

Valve Size	Nor-Cal 2-piece Hard Stop	Nor-Cal 3-piece Hard Stop
250mm	3870-04447	3870-04590
350mm	3870-04448	3870-04591

NOTE

There are many different types of hard stops for the Pendulum Valve line. Please take note of which hard stop is used in your valve.

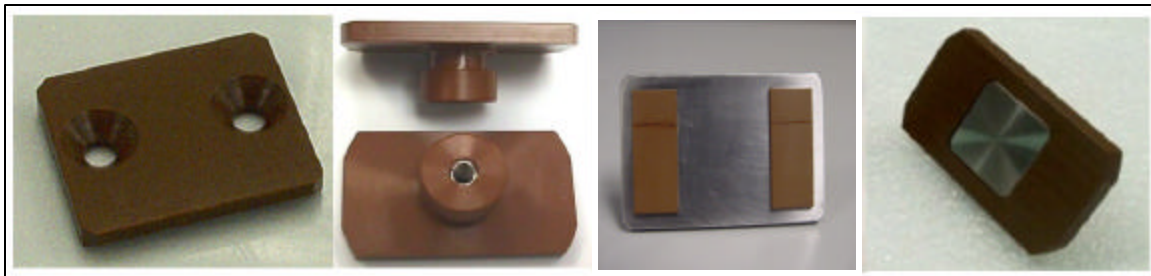

[Figure 11-A. Some different Hard Stop types]

NOTE

To access the Hard Stop with the Gate Valve mounted on the tool, use the Hard Stop Removal tool provided in the Nor-Cal tool Kit.

For 200mm Pendulum Valves, please skip to step 11.7

- 11.1 For 250 and 350mm valves, remove the outer cap of the hard stop on the side of the valve.

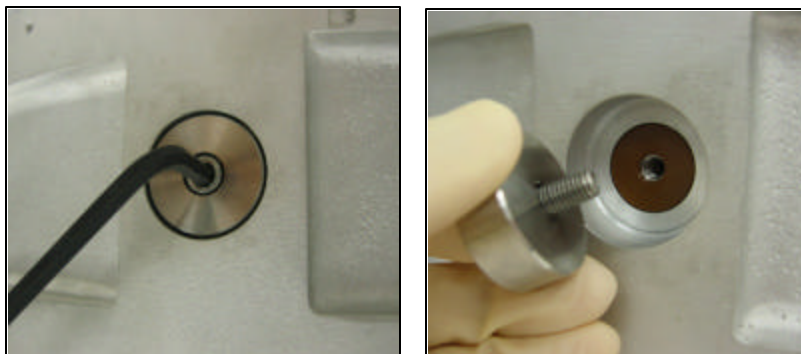

[Figure 11-B. Remove the Hard Stop Cap]

- 11.2 Use the Nor-Cal Hard Stop Removal Tool to push the hard stop through the body.

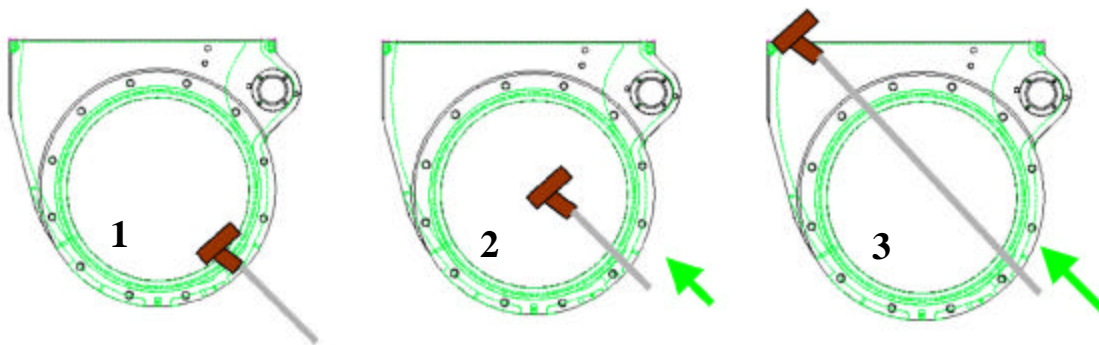

[Figure 11-C. Remove the Hard Stop Cap]

- 11.3 Remove the Hard Stop from the tool, and reverse the steps to reinstall the new hard stop and o-ring.

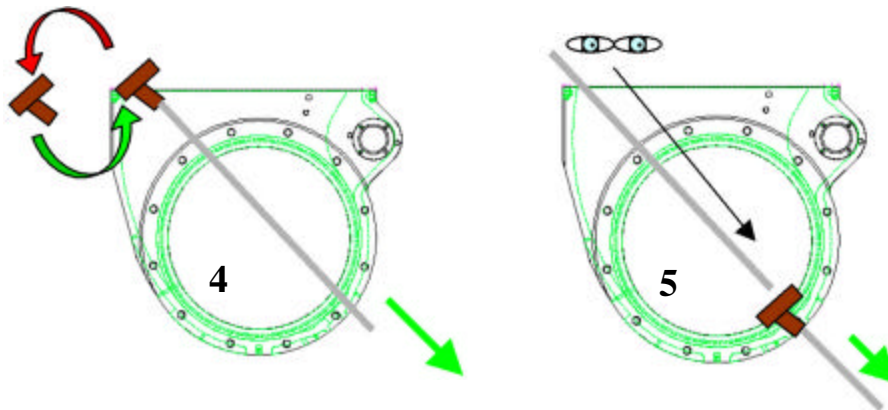

[Figure 11-D, Installation of the hard stop]

- 11.4 Inspect 2-piece hard stops and Vespel Hard Stops for erosion from process chemicals. On 2-piece hard stops, make sure there is no metal-to-metal contact from the Gate Stopper hitting the metal plug of the 2-piece hard stop. If excessive wear or metal-to-metal contact is observed, replace the hard stop.

- 11.5 When installing the Hard Stop, be sure the Hard Stop is square in the side of the body, not diagonal (Figure 11-E). **Look into the valve through the Bonnet, and inspect the hard stop orientation with a flashlight before torquing the bolt.**



[Figure 11-E, Incorrect (diagonal) installation of the hard stop]

- 11.6 Never apply Loctite to the hard stop bolt upon re-install



Over torque will break the Vespel Hard Stop. Do not over torque the bolt.

- 11.7 For 200mm Hard Stops, use the Nor-Cal Hard Stop Extension and 3mm socket head to remove the 2 flat-head bolts in the Hard Stop. There is no hole through the body.
 11.8 Change the hard stop and replace the 2 flat-head bolts. Never apply Loctite to the Hard Stop bolts.
 11.9 When installed correctly, torque the Hard Stop bolts to 30 in-lb.

All Valves
30 in-lb.



The Hard Stop is a piston-seal type.

If there is a leak at the hard stop, **increasing the torque WILL NOT stop the leak. Increasing the torque on the hard stop will break it!** This can cause permanent damage to the Gate Valve and possibly other components of the system such as the Turbo Pump. Make sure the hard stop is installed correctly. If you are unsure, ask a supervisor, or contact a local Nor-Cal Products representative.

 **NOTE**

A leak through the gate seal is an indicator that the hard stop is not installed correctly. If the Hard stop is installed incorrectly, the Gate will not fully close, and the o-ring may be visible (Fig 11-F)

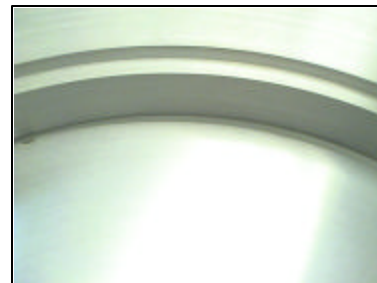

[Figure 11-F, Gate does not close completely when hard stop is installed incorrectly.]

Section 12 Installing the Gate Assembly

- 12.1 Spread ¼ bead of Krytox® LVP bead on the non-threaded (shoulder) surface of the Power Bolt.



[Figure 12-A, Spread ¼ bead on the Power Bolt shoulder]

- 12.2 Reinstall Gate Assembly back on to Gate Arm lifting it up and on, to avoid scratching the underside of the Gate Assembly. Locate the threads in the gate arm with your little finger, and center the Gate Assembly on the Gate Arm.



DO NOT use Loctite when installing the Power Bolt.

- 12.3 Make sure the Power Bolt washer is oriented correctly, with the round side towards the head of the bolt. This ensures the washer will lay flat on the Power Bolt without any gap.

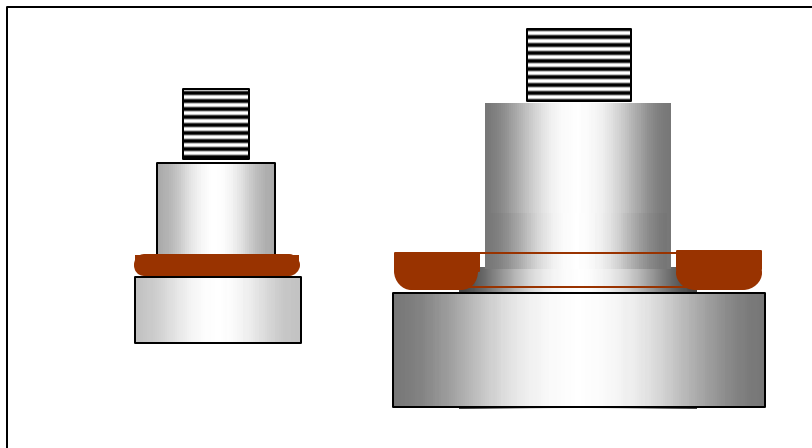

[Figure 12-B, Install the Power Bolt Washer with the round side towards the head]



V-Tex 250 & 350 valves do not use a Power Bolt washer

Use the long-shank socket extension to torque the Power Bolt.

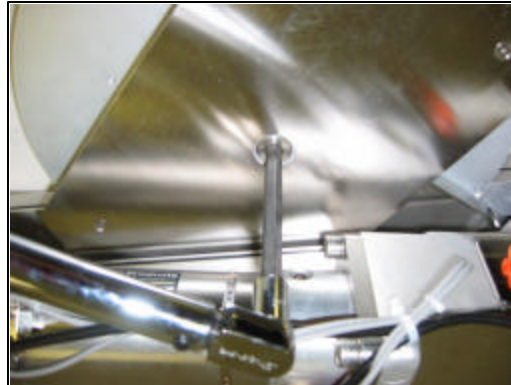

350 Valve	250 Valve	200 Valve
450 in-lb.	350 in-lb.	150 in-lb.

[Figure 12-C, Torque the Power Bolt]

- 12.4 After torquing the Power Bolt twist the Gate back and forth around the Power Bolt to make sure the Gate assembly moves freely using only 2 fingers to hold it. (Figure 12-D.) If there is binding, check the orientation of the Power Bolt washer in Step 12.3. Switching to a slightly thinner Power Bolt washer may solve the binding problem.

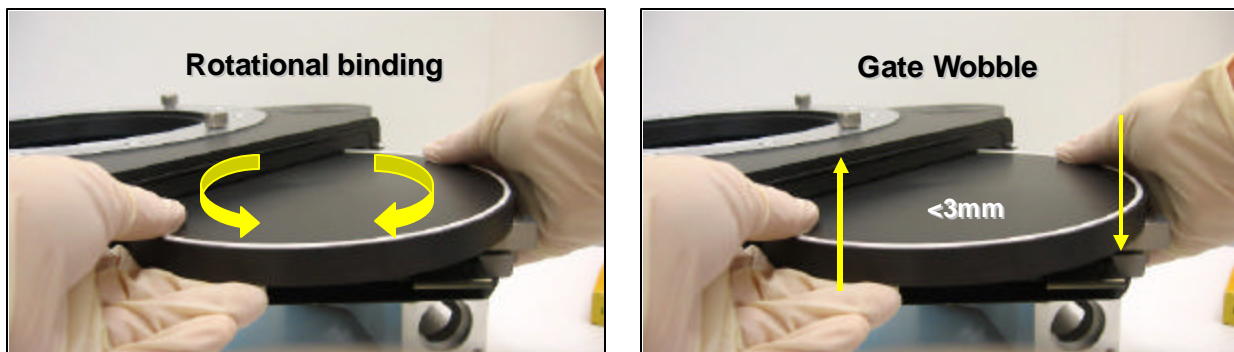

[Figure 12-D, Check Gate for rotational binding and Gate wobble]

- 12.5 Check for Gate "wobble" by lifting up and down on both sides of the Gate. If there is significant Gate wobble (more than 3mm of travel) the Power Bolt and/or Gate Arm threads may be damaged. In this case, loosen Power Bolt, clean all threads, and re-try. If this does not solve the wobble problem, replace the Power Bolt and the Gate Arm. See Section 4.13 for more information on Power Bolt and Gate Arm damage.

 **NOTE**

No wobble and a loose, non-binding gate are ideal. However, it is better to have a slight wobble than to have a tight gate that does not rotate. The Power Bolt Washer thickness and overtorque Damage determines the amount of gate binding, and contributes to the degree of wobble. The Gate Arm and Power Bolt may need to be replaced if binding or excess wobble is present.

- 12.6 Use the Spring Hook to reinstall the Coil Spring, then add the Spring Cover.
 Torque Spring Cover Plate captive bolts.

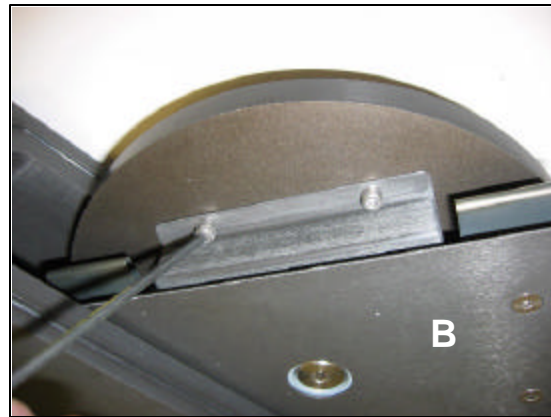
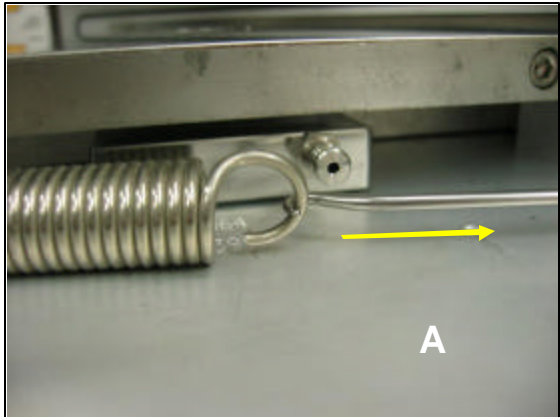

All Valves

25 in-lb.

[Figure 12-E, Add the Coil Spring and the Spring Cover]

- 12.7 Wipe down the Gate Assembly again using IPA or DI water, and finish with clean dry disposable cleanroom wipes. Do not let IPA drip into the gate mechanism. Use a dry cleanroom swab to remove any grease that has been worked out of the roller slots.
- 12.8 Gently push the Gate Assembly back into the valve body, and verify there is no mechanical scraping during opening/closing. If there is mechanical scraping, the gate Arm Height may need to be readjusted.
- 12.9 Clean the inside of bonnet with IPA and a cleanroom wipe, followed by a DI wipe and dry wipe.
- 12.10 Wipe down the Bonnet flange, o-ring and external flange mating area with IPA or DI, then re-install the Bonnet onto the gate valve housing. Make sure you do not damage the Bonnet sealing surface by bumping the Bonnet against the alignment pins.

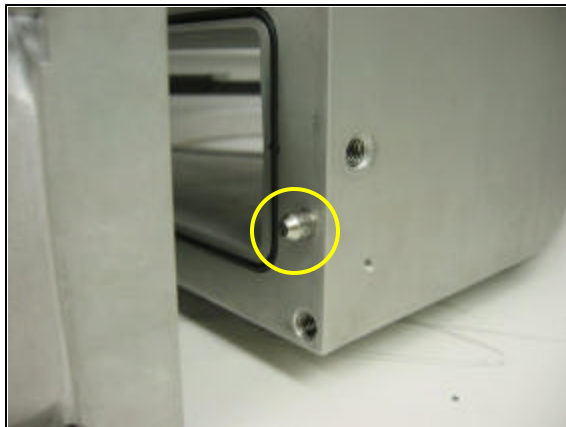

[Figure 12-F, Avoid damage to the Bonnet sealing surface]

- 12.11 Torque bonnet bolts to 100 in-lb.

All Valves

100 in-lb.

- 12.12 Re-connect the air lines and power cables, power-up and perform chamber leak-ups.

Section 13 TPV Sensors and Settings

Linear Sensor Setting (TPV Valves Only)

- 13.1 Attach the electrical connection (DB9 connector) to the Closed Position Sensor, and apply power.

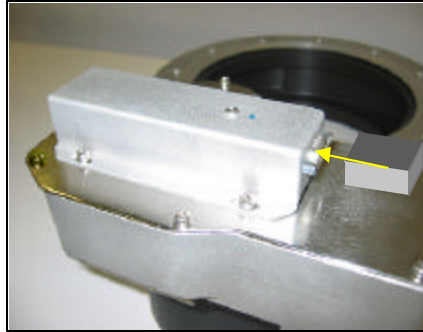

[Figure 13-A, Attach the DB9 Connector]

- 13.2 Loosen the four M4 screws that hold the Closed Position Sensor Bracket Assy to the Case Cover.
13.3 Slide the Sensor Bracket Assembly toward the Actuator end of the Case as far as it will go.

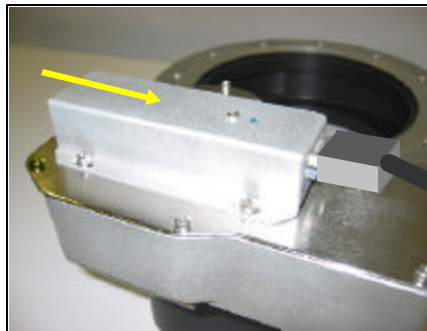

[Figure 13-B, Slide the Sensor towards the actuator]

- 13.4 Command the valve to 10% valve position.
13.5 Slide the Closed Position Sensor Bracket Assy until the Sensor indicator LED goes on.

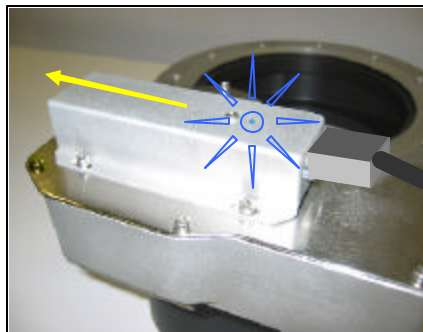

[Figure 13-C, Slide the cover back until the blue LED illuminates]

- 13.6 Tighten the four M4 screws.

Rotary Flag Sensor Setting (TPV Valves only)

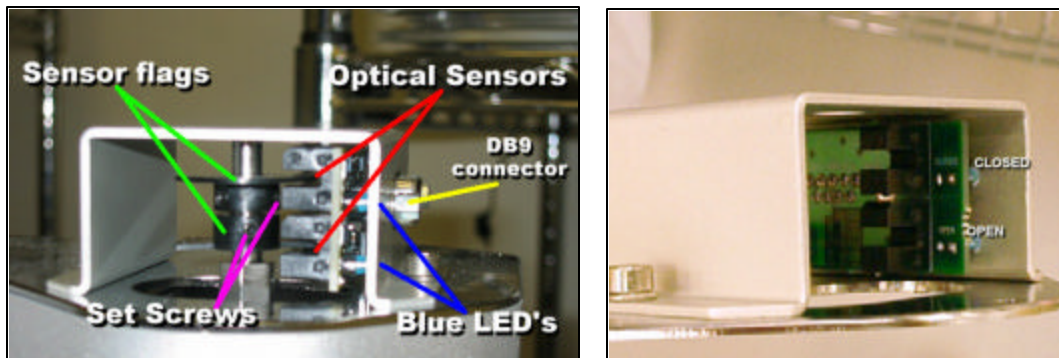

[Figure 13-D, Rotary Flag Sensors]

- 13.7 Using a valve controller (APC or IQ), or the screwdriver manual drive on the end of the motor block, place the valve in the full closed position.
- 13.8 If a lockout solenoid is attached to the side of the gear case, be sure it is disengaged, so as not to lock the gate in a closed position. Use a plastic spacer or alligator clip to keep the pin from engaging.

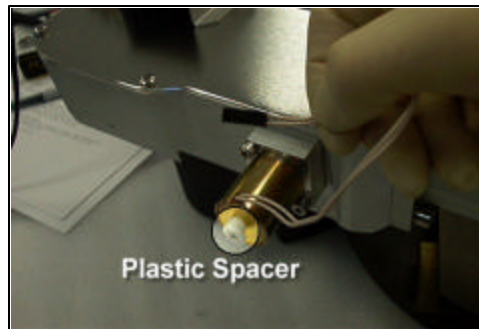

[Figure 13-E, A spacer on the solenoid keeps it from engaging]

- 13.9 Plug-in the Limit Switch Power Supply to the DB-9 connector.
- 13.10 On the Closed plastic flag, loosen the 3 hex-head set-screws with a 1.5mm Allen wrench. A ball-end Allen wrench is very helpful.
- 13.11 Swing the loose plastic flag in and out of the sensor area to make sure the Limit Switch Power Supply is working correctly. The Closed LED should illuminate and extinguish accordingly.

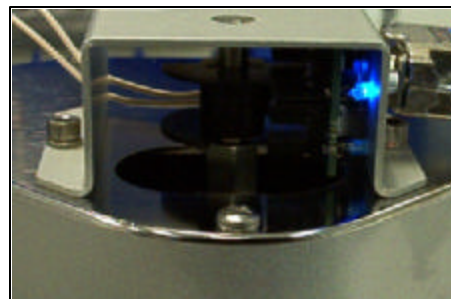

[Figure 13-F, "Closed" Indicator]

- 13.12 When you have verified that the power supply is connected correctly, and the valve is in the full-closed position, simply adjust the flag such that it illuminates the top LED, and gently tighten one of the set screws to hold it in place. Note that tightening the set screw may shift the flag, so pay close attention.
- 13.13 Actuate the valve to the full-open position, and then return it to the full closed position. Verify the proper “Closed” LED illuminates when the valve reaches the closed position. Nor-Cal recommends the “Closed” indicator illuminate between 3% and 10% of valve angle. A re-adjustment may be performed if it is not perfect the first time.
- 13.14 Once the “Closed” flag is fine-set as you require, tighten the remaining set-screws on the “Closed” flag.
- 13.15 For the “Open” sensor flag, place the valve in the full open position, and adjust the bottom flag in a similar manner.

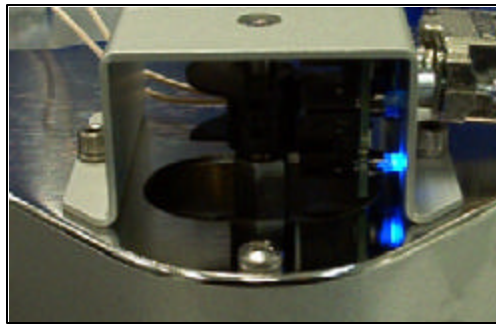

[Figure 13-G, “Open” Indicator]

- 13.16 Nor-Cal recommends the “Open” indicator illuminate between 90% and 100% of valve angle.

 **NOTE**

The rotary sensor flag Assembly is very sensitive to motion. Removing the Case cover and replacing it may shift the position of the sensors, causing an inaccurate reading. Pay attention to the settings.

 **NOTE**

The rotary sensor flag Assembly can be upgraded to a Linear Sensor Assembly. However, the Linear Sensor Assembly only provides a “closed” indication, and requires a new cover for the case to accommodate the assembly.

Section 14 Pneumatic Isolation Valve Sensors and Settings

NOTE: The sensors are set at the factory, and unless they are bumped or damaged in the field, *there is no need to adjust these sensors.* However, if there is a problem in the field, a 9-Volt battery circuit is required to provide the proper voltage and current to the when positioning the sensors on the air cylinder:

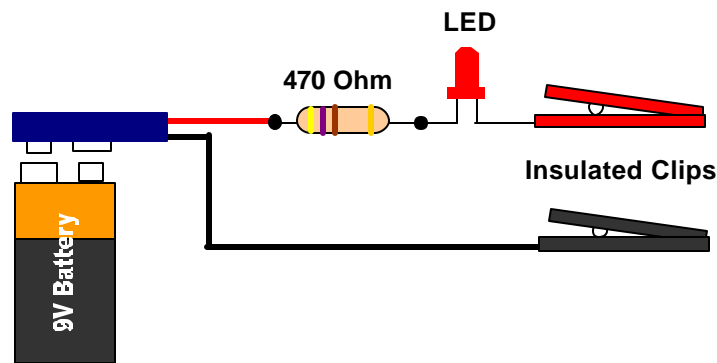
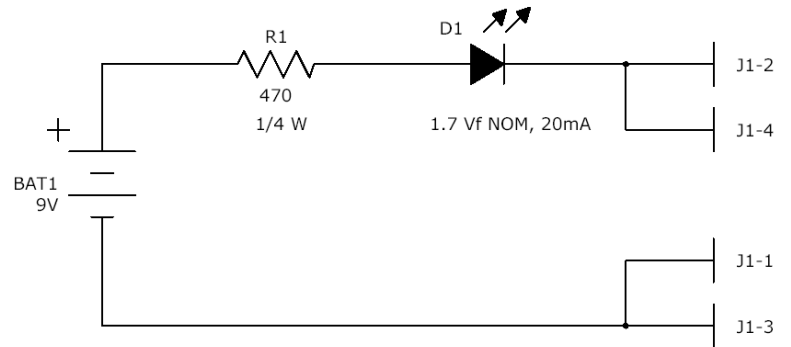

When the clip-leads are attached to the pins in the connector, the LED on this test circuit will illuminate when the sensor is activated.

Alternately, a pre-fabricated 9V test fixture which connects directly to the AMP connector on the sensor leads is available from Nor-Cal Products:

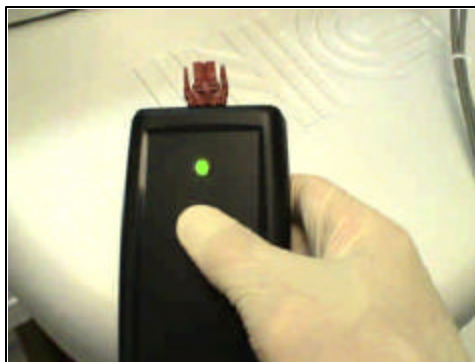

The procedure to set the position of the sensors is below.

- 14.1 Loosen the sensor attachment strap screws and leave the screws loose enough to slide the sensors back and forth on the actuator.
- 14.2 Position the 2 sensors all the way at either end, one at the Case end, and the other at the open end. (Fig 14-A)

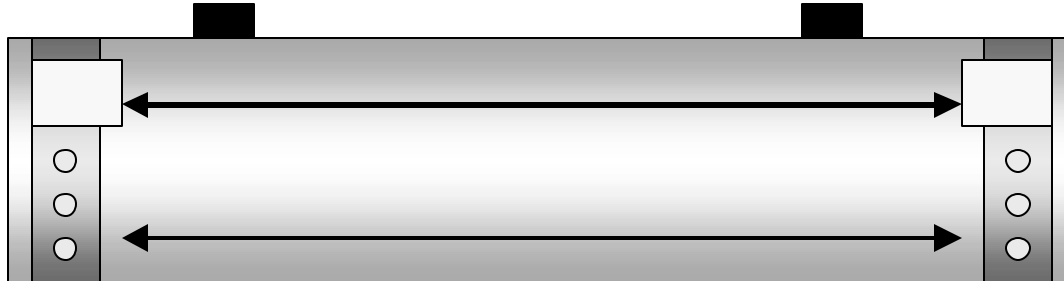

[Figure 14-A, Move Sensors to the ends]

- 14.3 Apply air pressure to the pendulum valve, *closing* the gate.

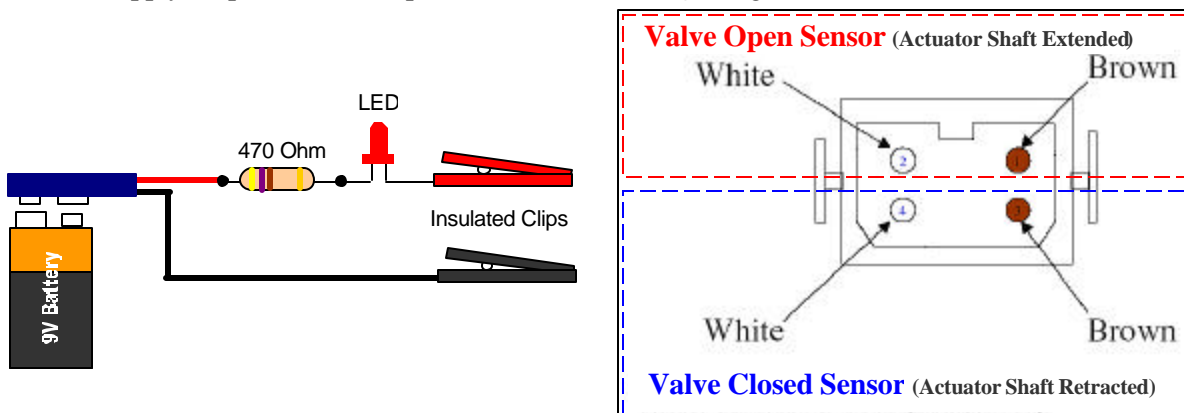

[Figure 14-B, Attach the 9V test circuit to the connector]

- 14.4 Attach the 9V test circuit to pins 3 & 4 of the connector.
- 14.5 *Slowly*, slide the closed sensor toward the center of the actuator. (Fig. 14C) Stop sliding the sensor when the LED on the 9V test circuit illuminates.
- 14.6 Tighten the strap screw at this position. Only the FIRST position is accurate.
- 14.7 Actuate the air solenoid, *opening* the valve's gate. Move the test leads to pins 1 and 2.
- 14.8 *Slowly*, move the open sensor (nearest the gear box) towards the center of the actuator until the LED on the 9V test circuit illuminates, and then tighten the strap screws.



[Figure 14-C, Push the sensor toward the center until the LED on the 9V test circuit illuminates]

US-Built, Nor-Cal Speed and Cushion Adjustment Procedure

For the V-TEX procedure, skip to step 14.12



Caution must be used in attempting to increase valve cycle speed. Forcing the valve to move faster can result in serious damage to internal components and affect the warranted performance.

- 14.9 **Cushion Control:** Adjust the Stroke Cushion Controls (Figure 14-C). Using a 1/8" hex wrench, rotate the adjusting screw clockwise until it lightly bottoms out in its closed position. Do not over tighten.
- 14.10 Rotate the adjusting screw counterclockwise 1/4 turn [90 deg.] Perform this adjustment to both cushion controls. This is the "factory pre-set" position.

NOTE

The total effective range of the cushion adjustment is 1/8 to 1 1/4 turns counterclockwise. If the customer specified total cycle time requirements differ from the factory pre-set, adjust both cushions by 1/8-turn increments until the specifications are achieved.

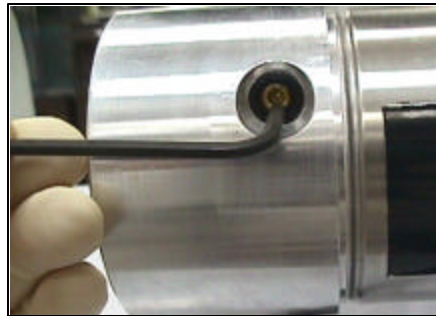

[Figure 14-D, Nor-Cal IPV Cushion Control]

- 14.11 **SPEED Control:** Adjust the Stroke Speed Regulator controls (Figure 14-D.) Using the thumbscrew on the control, rotate the screw clockwise until lightly seated. Metal air fittings employ a setscrew instead of a thumbscrew.
- 14.12 Once the screw is seated, rotate-out the screw counterclockwise 9 turns. This is the "factory pre-set" position, and will give a valve actuation speed of 4-5 seconds.



[Figure 14-E, Examples of Nor-Cal IPV Speed Controls]

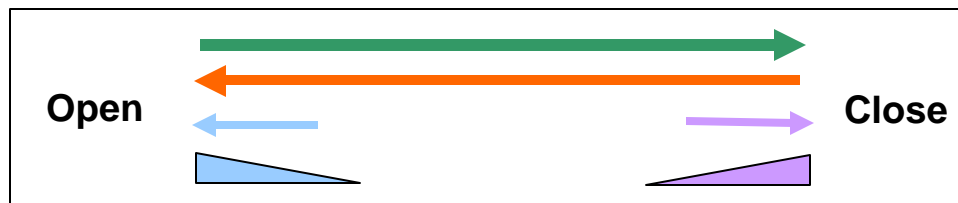
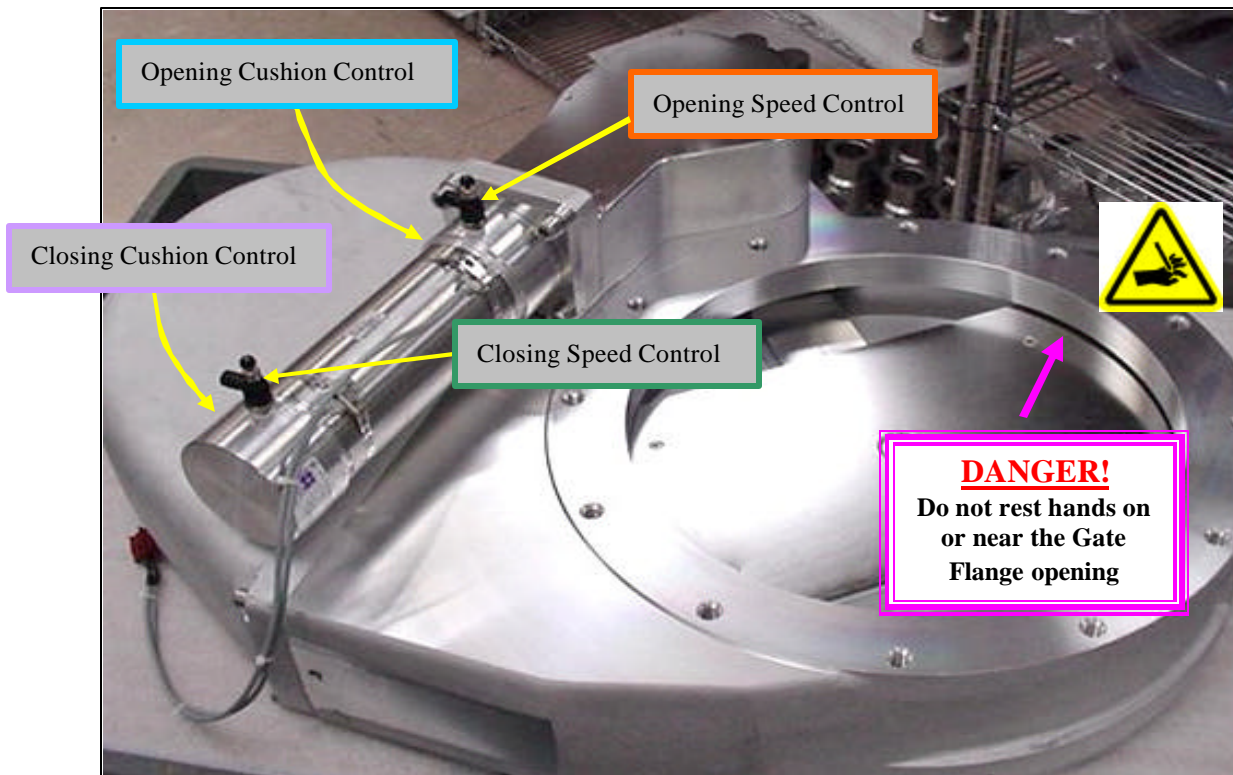

[Figure 14-F, Adjustment locations and a graphical representation of control]

Open/Close Speed

Green Closing speed is controlled by the outboard flow regulator on the end of the actuator.

Orange Opening speed is controlled by the inboard flow regulator closest to the gear case.

Cushion Controls

Purple The area of cushion controlled while the valve is closing.

Blue The area of cushion controlled while the valve is opening.

NOTE

Represented in the diagrams above are the cushion and flow regulator locations and the associated area of the stroke in which they control. When adjusting them, consider that the open to close time and close to open time will greatly affect the setting of the cushion adjustments.

Japan-Built, V-Tex Actuator Adjustment Procedure

- 14.13 **Speed Control:** Loosen the knurled jam-nut on the "OPEN" speed regulator full counterclockwise, so it is backed-up against the setting knob.
- 14.14 Bring the knob and jam-nut clockwise all the way in to the closed position until they bottom out.
- 14.15 Noting a mark on the setting knob, back out the knob counterclockwise 9 full turns.
- 14.16 Tighten the knurled jam-nut down clockwise, locking the setting knob so it does not move.
- 14.17 Repeat the above steps for the "CLOSE" speed regulator.

If necessary, fine-adjust the speed controls, in or out with ¼ turn increments to achieve a 4 to 6 second actuation time.

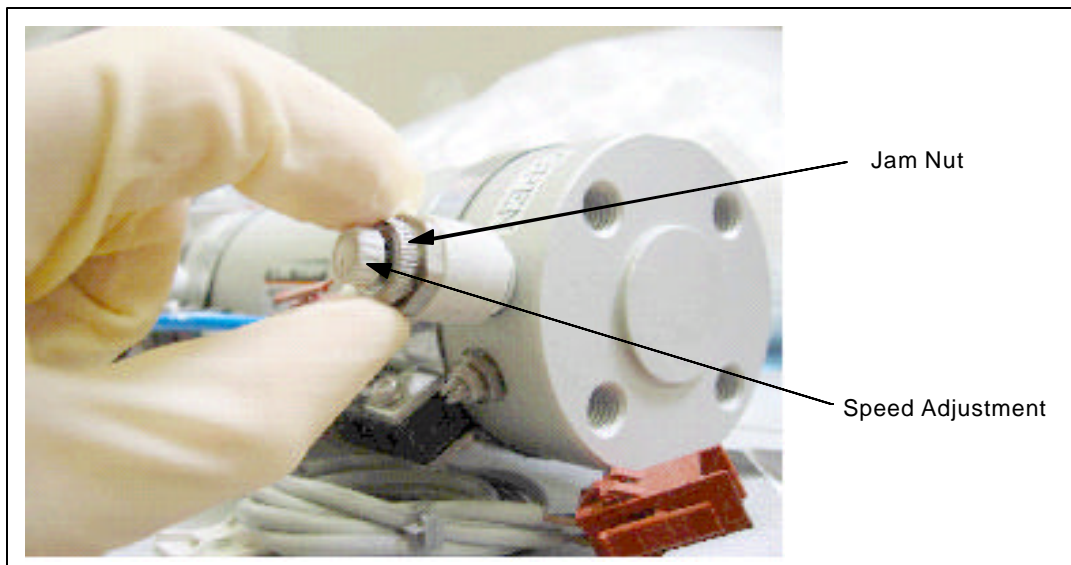

[Figure 14-G, V-Tex Speed Control]

- 14.18 **Cushion Control:** Loosen the 10mm jam-nut on the "CLOSE" cushion control.
- 14.19 With a screwdriver, turn in the cushion control clockwise, all the way in until it bottoms out, keeping the jam nut loose.
- 14.20 Back out the cushion control 1/8 to 1/4 turn, and tighten the 10mm jam-nut.
- 14.21 With 80 psi air pressure applied to the actuator (specification for air pressure: 65psi to 87 psi), test the speed of the open and close actuation. It should be 4 to 6 seconds.

Appendix A
Spare Parts

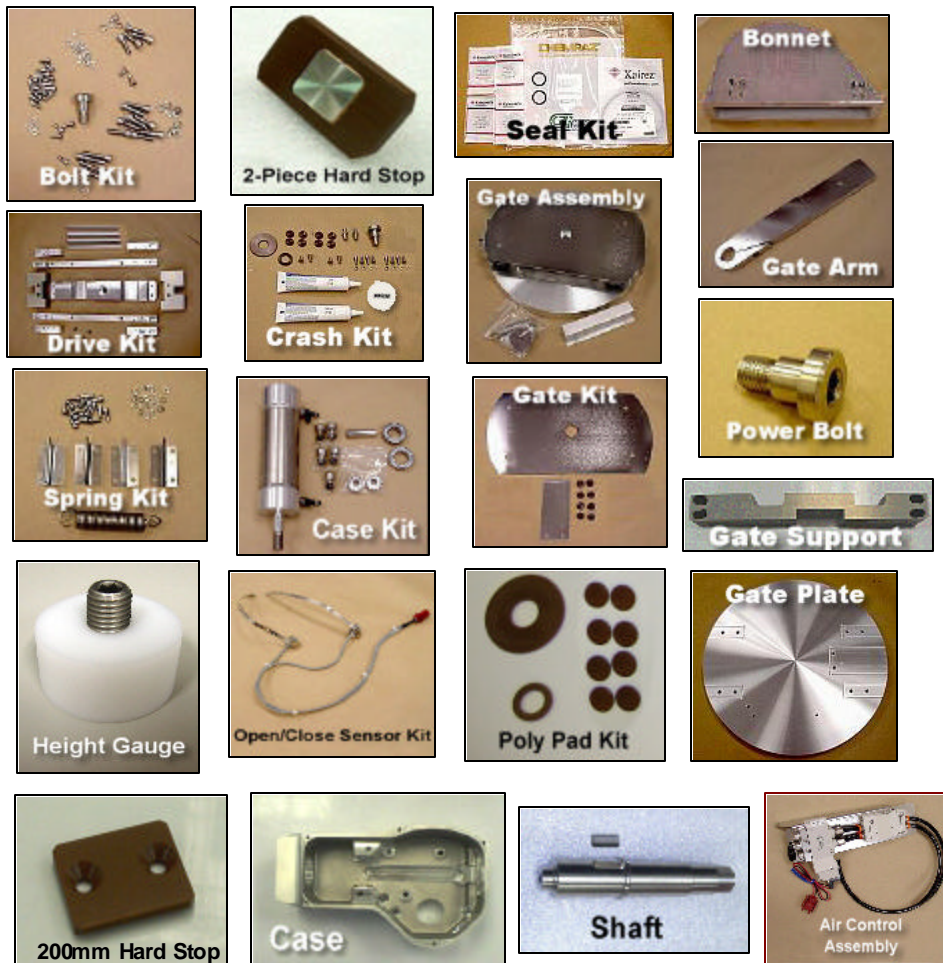

Photos of Spares & Kits

NOTE: Spares Kit photos are examples only.
 Kits for specific valve configurations may vary accordingly

[Figure A-1, Spare Part Kits Photos (examples only)]

 **NOTE**

Nor-Cal defines the valve size by the main bore opening, not by the size of wafer processed in the tool. Please refer to the part number for confirmation.

350mm Pendulum Valves

350mm Kits	350mm USA Nor-Cal Valves	350mm Japan VTEX Valves
350 Crash Kit	3870-04681	3870-03570
350 Seal Kit *	3870-03698	3870-03698
350 Spring Kit	3870-03601	3870-03574
350 Gate Assembly	3870-03602	3870-00915
350 Drive Kit	3870-04682	3870-04675
350 Gate Kit	3870-04871	3870-03576
350 Poly Pad Kit	No AMAT P/N Assigned	No AMAT P/N Assigned
350 Case Kit	3870-03605	3870-03577
350 Bolt Hardware Kit	3870-04683	3870-03578
350 Gate Arm	3870-04684	3870-04674
350 Air Control Assembly Kit	3870-03608	3870-03580
350 Bonnet	3870-03609	3870-03581
350 Hard Stop (1-piece)	3870-03610 (1-pc. Vespel)	3870-03582 (Stainless)
350 Hard Stop (2-piece)	3870-04448	Not available for VTEX valves
350 Hard Stop (3-piece)	3870-04591	Not available for VTEX valves
350 Gate Support (all 3-pieces)	3870-03611	3870-04676
350 IPV Open/Close Sensors (set of 2)	3870-04685	3870-03584
350 Gate Plate, (Plate only, for E38 o-ring)	3870-03613	3870-00938
350 Gate Plate, (Plate only, for 4079 o-ring)	3870-04277	Not Available for VTEX Valves
350 Power Bolt	3870-03614 (includes washer)	3870-00945
350 Gate Arm Shaft (includes key)	3870-03680	3870-04677
350 Gate Arm Height Gauge	3870-03561	3870-03561
350 Case	No AMAT P/N Assigned	No AMAT P/N Assigned
Pendulum Valve Tool Kit	3870-03699	3870-03699

* All O-rings are also available separately from the Seal Kit, directly through AMAT.

250mm Pendulum Valves

250mm Kits	250mm USA Nor-Cal Valves	250mm Japan VTEX Valves
250 Crash Kit	3870-04678	3870-03586
250 Seal Kit *	3870-03682	3870-03587
250 Spring Kit	3870-03683	3870-03588
250 Gate Assembly	3870-03684	3870-00958
250 Drive Kit	3870-04679	3870-03589
250 Gate Kit	3870-03686	3870-03590
250 Poly Pad Kit	No AMAT P/N Assigned	No AMAT P/N Assigned
250 Case Kit	3870-03687	3870-03591
250 Bolt Hardware Kit	3870-03688	3870-03592
250 Gate Arm, 14.8 degree	3870-04680	3870-04686
250 Air Control Assembly Kit	3870-03690	3870-03594
250 Bonnet	3870-03691	3870-03595
250 Hard Stop (1-piece)	3870-03692	3870-03596
250 Hard Stop (2-piece)	3870-04447	Not Available for VTEX Valves
250 Hard Stop (3-piece)	3870-04590	Not Available for VTEX Valves
250 Gate Support	3870-03693	3870-03594
250 IPV Open/Close Sensors (set of 2)	3870-03694	3870-03598
250 TPV Linear "Closed" sensor	No AMAT P/N Assigned	No AMAT P/N Assigned
250 Gate Plate (plate only)	3870-03695	3870-00921
250 Power Bolt	3870-03696 (includes washer)	3870-00926
250 Gate Arm Shaft (includes key)	3870-03697	3870-03599
250 Gate Arm Height Gauge	3870-03560	3870-03560
250 Case	No AMAT P/N Assigned	No AMAT P/N Assigned
Pendulum Valve Tool Kit	3870-03699	3870-03699

* All O-rings are also available separately from the Seal Kit, directly through AMAT.

200mm Pendulum Valves (USA Nor-Cal Only)

NOTE: Items with 1 part number are identical for Standard and Symmetrical valves

200mm Kits	200mm Standard Valves	200mm Symmetrical Valves
200 Crash Kit	3870-04175	
200 Seal Kit *	3870-04176	
200 Spring Kit	3870-04177	
200 Gate Assembly	3870-04178	3870-04184
200 Drive Kit	3870-04179	3870-04185
200 Gate Kit	3870-04180	
200 Poly Pad Kit	3870-04181	
200 Case Kit	3870-04275	3870-04182
200 Bolt Hardware Kit	No AMAT P/N Assigned	
200 Gate Arm	No AMAT P/N Assigned	No AMAT P/N Assigned
200 Air Control Assembly Kit	No AMAT P/N Assigned	No AMAT P/N Assigned
200 Bonnet	No AMAT P/N Assigned	No AMAT P/N Assigned
200 Hard Stop	3870-04186	
200 Gate Support	No AMAT P/N Assigned	No AMAT P/N Assigned
200 TPV Rotary Open/Close Sensors	3870-04187	
200 TPV Linear "Closed" sensor	No AMAT P/N Assigned	
200 Gate Plate (plate only)	No AMAT P/N Assigned	No AMAT P/N Assigned
200 Power Bolt	3870-04188	
200 Gate Arm Shaft (includes key)	No AMAT P/N Assigned	No AMAT P/N Assigned
200 Gate Arm Height Gauge	No AMAT P/N Assigned	
200 Case	No AMAT P/N Assigned	No AMAT P/N Assigned
Pendulum Valve Tool Kit	3870-03699	3870-03699

* All O-rings are also available separately from the Seal Kit, directly through AMAT.