

FOR SALES AND SERVICE PLEASE CALL:

PTB SALES T :: 626.334.0500
service@ptbsales.com
www.ptbsales.com

DATE SERVICED: _____

VIEW OUR INVENTORY

TV 1001 Navigator

Pump models: 969-8931, 969-8932,
969-8934, 969-8946, 969-8933, 969-8947

Kit models: 969-8838, 969-8839, 969-8841,
969-8844, 969-8840, 969-8845

Controller models: 969-8978

[Manual de Instrucciones](#)
[User Manual](#)

87-900-945-01 (I)

04/2011



Agilent Technologies

Notices

© Agilent Technologies, Inc. 2011

No part of this manual may be reproduced in any form or by any means (including electronic storage and retrieval or translation into a foreign language) without prior agreement and written consent from Agilent Technologies, Inc. as governed by United States and international copyright laws.

Manual Part Number

Publication Number: 87-900-945-01 (I)

Edition

Edition 04/2011

Printed in ITALY

Agilent Technologies Italia S.p.A.

Vacuum Products Division

Via F.lli Varian, 54

10040 Leini (TO)

ITALY

Warranty

The material contained in this document is provided “as is,” and is subject to being changed, without notice, in future editions. Further, to the maximum extent permitted by applicable law, Agilent disclaims all warranties, either express or implied, with regard to this manual and any information contained herein, including but not limited to the implied warranties of merchantability and fitness for a particular purpose. Agilent shall not be liable for errors or for incidental or consequential damages in connection with the furnishing, use, or performance of this document or of any information contained herein. Should Agilent and the user have a separate written agreement with warranty terms covering the material in this document that conflict with these terms, the warranty terms in the separate agreement shall control.

Technology Licenses

The hardware and/or software described in this document are furnished under a license and may be used or copied only in accordance with the terms of such license.

Restricted Rights Legend

If software is for use in the performance of a U.S. Government prime contract or subcontract, Software is delivered and licensed as “Commercial computer software” as defined in DFAR 252.227-7014 (June 1995), or as a “commercial item” as defined in FAR 2.101(a) or as “Restricted computer software” as defined in FAR 52.227-19 (June 1987) or any equivalent agency regulation or

contract clause. Use, duplication or disclosure of Software is subject to Agilent Technologies’ standard commercial license terms, and non-DOD Departments and Agencies of the U.S. Government will receive no greater than Restricted Rights as defined in FAR 52.227-19(c)(1-2) (June 1987). U.S. Government users will receive no greater than Limited Rights as defined in FAR 52.227-14 (June 1987) or DFAR 252.227-7015 (b)(2) (November 1995), as applicable in any technical data.

Trademarks

Windows and MS Windows are U.S. registered trademarks of Microsoft Corporation.

Safety Notices

CAUTION

A **CAUTION** notice denotes a hazard. It calls attention to an operating procedure, practice, or the like that, if not correctly performed or adhered to, could result in damage to the product or loss of important data. Do not proceed beyond a **CAUTION** notice until the indicated conditions are fully understood and met.

WARNING

A **WARNING** notice denotes a hazard. It calls attention to an operating procedure, practice, or the like that, if not correctly performed or adhered to, could result in personal injury or death. Do not proceed beyond a **WARNING** notice until the indicated conditions are fully understood and met.

TV 1001 Navigator



Contents

1 Istruzioni per l'uso 15

Indicazioni di Sicurezza per Pompe Turbomolecolari 16

Informazioni Generali 17

Immagazzinamento 19

Preparazione per l'installazione 20

Installazione 21

Fissaggio della pompa 22

Uso 24

Manutenzione 27

Smaltimento 28

2 Gebrauchsanleitung 29

Sicherheitshinweise für Turbomolekularpumpen 30

Allgemeine Informationen 31

Lagerung 33

Vor der Installation 34

Installation 35

Befestigung der Pumpe 36

Gebrauch 38

Wartung 41

Contents

Entsorgung	42
3 Mode d'emploi	43
Normes de sécurité pour Pompe Turbomoléculaires	44
Indications générales	45
Stockage	47
Preparation pour l'installation	48
Installation	49
Fixation de la pompe	50
Utilisation	52
Entretien	55
Mise au rebut	56
4 Manual de instrucciones	57
Indicaciones de Seguridad para Bombas Turbomoleculares	58
Información general	59
Almacenamiento	61
Preparación para la instalación	62
Instalación	63
Fijación de la bomba	64
Uso	66
Mantenimiento	69
Eliminación	70

5 Manual de Instruções 71

Indicações de Segurança para Bombas Turbomoleculares 72

Informações gerais 73

Armazenagem 75

Preparação para a instalação 76

Instalação 77

Fixação da bomba 78

Utilização 80

Manutenção 83

Eliminação 84

6 Bedrijfshandleiding 85

Veiligheidsinstructies voor Turbomoleculaire pompen 86

Algemene informatie 87

Opslag 89

Uitpakken 90

Installatie 91

Bevestiging van de pomp 92

Gebruik 94

Onderhoud 97

Afvalverwerking 98

7 Istruktionsbog 99

Sikkerhedsanvisninger for Molekylære turbopumper 100

Contents

Generel information	101
Opbevaring	103
Forberedelser før installation	104
Installation	105
Fastgørelse af pumpe	106
Anvendelse	108
Nødstop	110
Vedligeholdelse	111
Bortskaffelse	112

8 Bruksanvisning 113

Säkerhetsanvisningar för Molekylära turbopumpar	114
Allmän information	115
Förvaring	117
Forberedelser før installation	118
Installation	119
Fastsättning av pump	120
Användning	122
Underhåll	125
Bortskaffning	126

9 Instruksjon Manual 127

Sikkerhetsanvisninger for Turbomolekylære pumper	128
Generell informasjon	129

Lagring	131
Klargjøre til installasjon	132
Installasjon	133
Festing av pumpen	134
Bruk	136
Vedlikehold	139
Eliminering	140
10 Ohjekäsikirja	141
Turbomolekyylipumppujen Turvaohjeet	142
Yleisiä tietoja	143
Varastointi	145
Valmistelut asennusta varten	146
Asennus	147
Pumpun kinnitys	148
Käyttö	150
Huolto	153
Hävittäminen	154
11 Felhasználói Kézikönyv	155
Biztonsági útmutató Turbómolekuláris szivattyúkhöz	156
Általános információ	157
Tárolás	159
Előkészítés telepítésre	160

Contents

Telepítés	161
A szivattyú rögzítése	162
Használat	164
Karbantartás	167
Megsemmisítés	168

12 Podrecznik Instrukcji 169

Wskazówki dotyczące bezpieczeństwa dla Pomp Turbomolekularnych	170
Informacje ogólne	171
Magazynowanie	173
Przygotowanie do instalacji	174
Instalacja	175
Mocowanie pompy	176
Użytkowanie	178
Konserwacja	181
Przetworstwo odpadów	182

13 Návod k Použití 183

Bezpečnostní návod pro Turbomolekulární vývěvy	184
Všeobecné informace	185
Uskladnění	187
Příprava k instalaci	188
Instalace	189
Montáž vývěvy	190

Použití	192
Údržba	195
Likvidace	196

14 Návod na Obsluhu 197

Bezpečnostné pokyny pre Turbomolekulárne vývevy	198
Všeobecné informácie	199
Uchovávanie	201
Príprava na inštaláciu	202
Inštalácia	203
Upevnenie vývevy	204
Použitie	206
Údržba	209
Likvidácia	210

15 Priročnik za Navodila 211

Varnostna navodila za Turbomolekularne črpalke	212
Splošne informacije	213
Shranjevanje	215
Priprava za montažo	216
Montaža	217
Pritrjevanje črpalke	218
Uporaba	220
Vzdrževanje	223

Contents

Odlaganje odpadkov 224

16 Instructions for Use 225

Safety Guideline for Turbomolecular Pumps 226

General Information 227

Storage 229

Preparation for installation 230

Installation 231

Pump fixing 232

Use 234

Maintenance 237

Disposal 238

17 Technical Information 239

Description of the TV 1001 Navigator 241

Technical Specification 248

TV 1001 Navigator Outline 250

Interconnections 254

RS 232/RS 485 Communication Description 266

Inlet Screen Installation 275

Heater Band Installation 278

Air Cooling Kit Installation 280

Water Cooling Kit Installation 284

Vent Accessories 287

Vibration Isolator Installation	291
Purge Valve Installation	292
Serial Cable Installation	293
TV 1001 Controller Installation	294
Pump Used with Corrosive Gases	302
Pump Used in Presence of Magnetic Fields	304
Accessories and Spare Parts	305

Contents

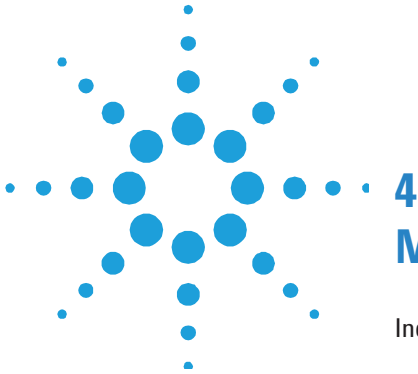

4 Manual de instrucciones

Indicaciones de Seguridad para Bombas Turbomoleculares	58
Información general	58
Almacenamiento	61
Preparación para la instalación	62
Instalación	63
Fijación de la bomba	64
Uso	66
Encendido y Uso del TV 1001 Navigator	67
Parada del TV 1001 Navigator	68
Parada de Emergencia	68
Mantenimiento	69
Eliminación	70

Traducción de las instrucciones originales



Indicaciones de Seguridad para Bombas Turbomoleculares

Las bombas Turbomoleculares descritas en el siguiente manual de instrucciones tienen una elevada cantidad de energía cinética debido a la alta velocidad de rotación en combinación a la masa específica de sus rotores.

En el caso de un daño del sistema, por ejemplo por un contacto entre el rotor y el estator o por una rotura del rotor, la energía de rotación podría ser liberada.

¡ADVERTENCIA!



Para evitar daños a los equipos y prevenir lesiones a los operadores, es necesario seguir atentamente las instrucciones de instalación descritas en el presente manual!

Información general

Este equipo es para uso profesional. El usuario ha de leer atentamente el presente manual de instrucciones y cualquier otra información suplementaria facilitada por Agilent antes de usar el aparato. Agilent se considera libre de posibles responsabilidades debidas al incumplimiento total o parcial de las instrucciones, al uso impropio por parte de personal no preparado, a operaciones no autorizadas o a un uso contrario a las normas nacionales específicas.

El TV 1001 Navigator es un sistema integrado compuesto por una bomba turbomolecular para aplicaciones de alto y ultra alto vacío integrada por el controler correspondiente. El sistema puede bombear cualquier tipo de gas o de composición gaseosa, pero no es adecuado para bombear líquidos o partículas sólidas. El efecto de bombeo se obtiene mediante una turbina rotativa de alta velocidad (38000 r.p.m. máx.) movida por un motor eléctrico trifásico de alto rendimiento. El TV 1001 Navigator no posee ningún agente contaminante y por lo tanto es adecuado para aplicaciones que requieren un vacío 'limpio'.

Asimismo, el TV 1001 Navigator posee conectores auxiliares con los que se puede alimentar un ventilador adicional, accionar la válvula de ventilación, pilotarla a distancia con un ordenador host conectado mediante línea serial (RS 232/RS 485).

A continuación se facilita toda la información necesaria para garantizar la seguridad del operador al usar el aparato. En el anexo "Technical Information" se facilita información más detallada.

4 Manual de instrucciones

Información general

Este manual utiliza las convenciones siguientes:

¡ATENCIÓN!

Los mensajes de atención se visualizan antes de los procedimientos que, al no respetarse, podrían provocar daños al equipo.

¡ADVERTENCIA!



Los mensajes de advertencia atraen la atención del operador sobre un procedimiento o una operación específica que, al no realizarse correctamente, podría provocar graves lesiones personales.

NOTA

Las notas contienen información importante extraída del texto.

Almacenamiento

Para garantizar el nivel máximo de funcionalidad y fiabilidad de las bombas turbomoleculares Agilent, deberán aplicarse las siguientes instrucciones:

- durante el transporte, desplazamiento y almacenamiento de las bombas no deberán superarse las siguientes condiciones ambientales:
 - temperatura: entre $-20\text{ }^{\circ}\text{C}$ y $70\text{ }^{\circ}\text{C}$;
 - humedad relativa: entre 0 y 95 % (no condensante);
- el cliente deberá activar siempre las bombas turbomoleculares en modalidad Soft-Start al recibirlas y ponerlas en funcionamiento por primera vez;
- el período máximo de almacenamiento de una bomba turbomolecular es de diez meses a contar de la fecha de envío al cliente.

¡ATENCIÓN!

En caso de superarse por cualquier motivo el período máximo permitido de almacenamiento, será necesario devolver la bomba al fabricante. Para mayores informaciones al respecto, se ruega contactar con el representante local de Agilent.

Preparación para la instalación

El TV 1001 Navigator se suministra en un embalaje especial de protección; si se observan daños, que podrían haberse producido durante el transporte, ponerse en contacto con la oficina local de ventas. Durante la operación de desembalaje, tener cuidado de que no se caiga el TV 1001 Navigator y de no someterlo a golpes o vibraciones. No abandonar el embalaje en el medio ambiente. El material es completamente reciclable y cumple con la directiva CEE 85/399 para la preservación del medio ambiente.

¡ATENCIÓN! Para evitar problemas de desgasificación, no tocar con las manos desnudas los componentes destinados a exponerse al vacío. Utilizar siempre guantes u otra protección adecuada.



Figura 1

NOTA

El TV 1001 Navigator no puede dañarse permaneciendo simplemente expuesto a la atmósfera. De todas formas, se aconseja mantener cerrada la bomba hasta que se instale en el sistema para evitar su posible contaminación por polvo.

Instalación

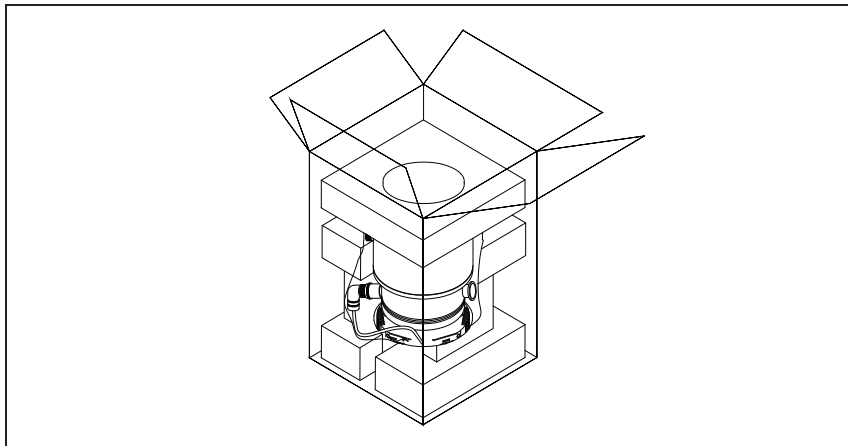
No instalar ni/o utilizar la bomba en lugares expuestos a agentes atmosféricos (lluvia, hielo y nieve), polvo y gases agresivos, en lugares explosivos o con alto riesgo de incendio. Durante el funcionamiento es necesario que se respeten las condiciones ambientales siguientes:

- presión máxima: 2 bares por encima de la presión atmosférica
- temperatura: de +5 °C a +35 °C (véase gráfico en el anexo “Technical Information”)
- humedad relativa: 0 – 95 % (no condensadora).

¡ATENCIÓN!

Despegar el adhesivo y quitar el tapón de protección sólo al conectar la bomba al sistema.



Figura 2

Cuando existan campos electromagnéticos, la bomba ha de protegerse mediante pantallas oportunas. Véase el anexo “Technical Information” para más detalles.

El TV 1001 Navigator ha de conectarse a una bomba primaria (véase diagrama en “Technical Information”).

Fijación de la bomba

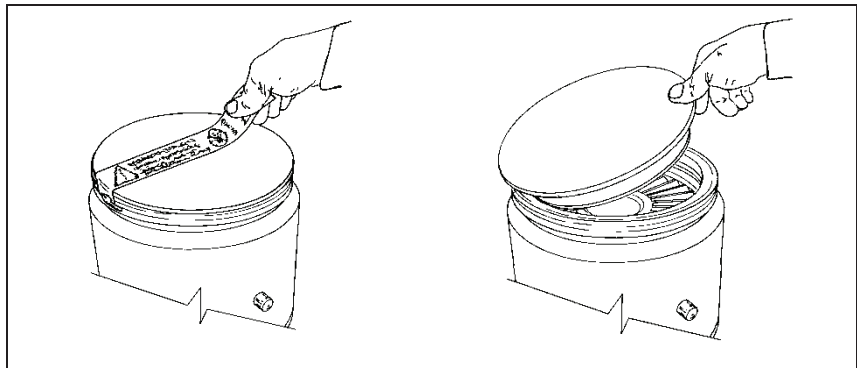
¡ADVERTENCIA!



En caso de dañarse el rotor, la conexión entre la bomba y el sistema puede ser sometida a un par de fuerza excesivo. En estas circunstancias, la conexión podría no resistir a dicho par de fuerza y, como consecuencia, la bomba podría separarse del sistema o el motor podría separarse respecto del contenedor de la bomba. En este caso fragmentos de metal pueden ser proyectados por la bomba o por el sistema, con consiguiente grave riesgo de lesiones o muerte y/o daños a los aparatos adyacentes.

Fijar el TV 1001 Navigator en posición estable, montando la brida de entrada de la turbo-bomba en la contrabrida del sistema, con conexión capaz de resistir a un par de 8900 Nm en torno a su propio eje. A modo de ejemplo, la brida ISO-K puede fijarse con mordazas de acero de alta resistencia (como el modelo Agilent IC 63250 DCMZ).

En la siguiente tabla se indican, respecto de cada brida, la cantidad de mordazas IC 63250 DCMZ necesarias y el par de apriete con el cual fijarlas.

Tab. 1

Brida	N.	Par de apriete
ISO 160	10	35 Nm
ISO 200	8	35 Nm
ISO 250	6	35 Nm

En la siguiente tabla se indican, respecto de cada brida ISO-F, la cantidad de los tornillos necesarios y el par de apriete con el cual fijarlas.

Tab. 2

Brida	N.	Par de apriete
ISO 200 F	12	5 Nm
ISO 250 F	12	5 Nm

En el caso de las bridas F los tornillos de acero deben ser de clase > 8.8

La turbobomba con brida de entrada ConFlat ha de fijarse a la cámara de vacío mediante los accesorios mecánicos específicos Agilent. Para más detalles véase el anexo “Technical Information”.

El TV 1001 Navigator puede instalarse en cualquier posición.

NOTA

El TV 1001 Navigator no puede fijarse utilizando su base.

¡ATENCIÓN!

El TV 1001 Navigator pertenece a la segunda categoría de instalación (o sobretensión) prevista por la normativa EN 61010-1. Por lo tanto este dispositivo debe ser conectado a una línea de alimentación adecuada para dicha categoría.

El TV 1001 Navigator tiene conectores para las entradas/salidas y para la comunicación serial que deben ser conectados a los circuitos externos de manera que ninguna parte bajo tensión quede accesible. Controlar que el aislamiento del dispositivo conectado al TV 1001 Navigator mantenga una acción aisladora incluso en caso de verificarse una avería, de conformidad con lo establecido por la normativa EN 61010-1.

Para instalar los accesorios opcionales, véase “Technical Information”.

Uso

En este apartado se citan los procedimientos operativos principales. Antes de usar el sistema realizar todas las conexiones eléctricas y neumáticas. Durante el posible calentamiento de la cámara de vacío, la temperatura de la brida de entrada no ha de ser superior a 120 °C.

¡ADVERTENCIA!



No hacer funcionar nunca la bomba si la brida de entrada no está conectada al sistema o no está cerrada con la brida de cierre. No tocar la turbo-bomba y sus posibles accesorios durante las operaciones de calentamiento. La alta temperatura puede provocar lesiones a las personas.

¡ATENCIÓN!

Evítense golpes, oscilaciones o bruscos desplazamientos de la turbobomba durante su funcionamiento. Los cojinetes podrían dañarse. Para el envío de aire de la bomba utilizar aire o gas inerte sin polvo o partículas. La presión de entrada a través de la puerta deberá ser inferior a 2 bar (por encima de la presión atmosférica). Para bombear gases agresivos estas bombas están dotadas de una puerta específica mediante la cual es necesario suministrar a la bomba un caudal de gas inerte (Nitrógeno o Argón) para proteger los rodamientos (véase el anexo "Technical Information").

¡ADVERTENCIA!



Cuando la bomba se utiliza para bombear gases tóxicos, inflamables o radioactivos, seguir los procedimientos apropiados típicos de cada gas. No usar la bomba cuando haya gases explosivos.

Encendido y Uso del TV 1001 Navigator

Para encender el TV 1001 Navigator basta con suministrar la tensión de alimentación. El controlador incorporado reconoce automáticamente la presencia de las señales de interbloqueo y de arranque y activa la bomba.

La modalidad “Soft Start” está prevista para poner en marcha la bomba luego de un período prolongado de inactividad.

Para utilizar una puesta en marcha “Soft Start” activa es necesario habilitar la forma anteriormente indicada mediante software (véase el apartado “RS 232/485 COMMUNICATION DESCRIPTION” en el anexo “Technical Information”).

El LED verde LD1 situado en el panel de la base del TV 1001 indica, con la frecuencia de su parpadeo, las condiciones operativas del sistema:

- encendido fijo: la bomba está en rotación normal;
- parpadea lentamente (periodo de 400 ms aproximadamente): el sistema está en estado de rampa, o de frenado, o de stop, o de “Waiting for interlock”;
- parpadea rápidamente (periodo de 200 ms aproximadamente): condición de error.

Parada del TV 1001 Navigator

Para parar el TV 1001 Navigator nte con desenchufarlo de la corriente. El controler incorporado detiene inmediatamente la bomba.

¡ADVERTENCIA!



Para seguridad del operador el controlador Turbo-V debe ser alimentado con cable de alimentación de 3 hilos (véase tabla de partes disponibles para pedido) provisto de un enchufe (aprobado internacionalmente). Utilizar el cable y el enchufe junto con un tomacorriente adecuadamente conectado a tierra para evitar descargas eléctricas y cumplir con los requerimientos de las normas CE. Las altas tensiones que se desarrollan en el controlador pueden provocar graves daños o incluso resultar fatales. Desconectar el cable de alimentación antes de ejecutar las operaciones de mantenimiento en el interior de la unidad. requerimientos de las normas CE.

Parada de Emergencia

Para detener en condiciones de emergencia el TV 1001 Navigator es necesario desconectar del controlador el cable de alimentación.

Mantenimiento

El TV 1001 Navigator no necesita ningún mantenimiento. Cualquier operación deberá ser realizada por personal autorizado.

¡ADVERTENCIA!



Antes de realizar cualquier operación en el sistema desconectarlo de la corriente, enviar aire de la bomba abriendo la válvula oportuna, esperar hasta que el rotor se pare completamente y esperar a que la temperatura superficial de la bomba sea inferior a 50 °C.

En caso de avería se podrá utilizar el servicio de reparación Agilent, que permite obtener una bomba regenerada para sustituir la averiada.

NOTA

Antes de enviar al fabricante una bomba para su reparación o “advanced exchange service”, es imprescindible cumplimentar y remitir a la oficina local de ventas la ficha de “Seguridad y Salud” adjunta al presente manual de instrucciones. Una copia de la misma se deberá introducir en el embalaje del sistema antes de enviarlo.

En caso de que la bomba se tenga que desguazar, eliminarla respetando las normas nacionales específicas.

Eliminación

Significado del logotipo "WEEE" presente en las etiquetas. El símbolo que se indica a continuación, es aplicado en observancia de la directiva CE denominada "WEEE". Este símbolo (**válido sólo para los países miembros de la Comunidad Europea**) indica que el producto sobre el cual ha sido aplicado, NO debe ser eliminado junto con los residuos comunes sean éstos domésticos o industriales, y que, por el contrario, deberá ser sometido a un procedimiento de recogida diferenciada. Por lo tanto, se invita al usuario final, a ponerse en contacto con el proveedor del dispositivo, tanto si éste es la casa fabricante o un distribuidor, para poder proveer a la recogida y eliminación del producto, después de haber efectuado una verificación de los términos y condiciones contractuales de venta.

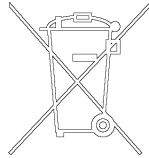

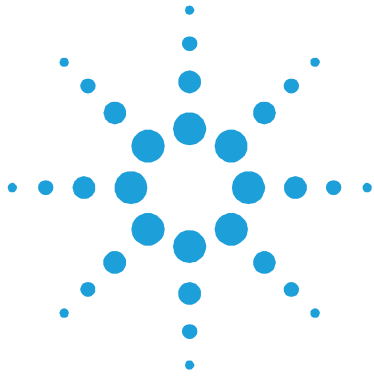

16 Instructions for Use

Safety Guideline for Turbomolecular Pumps	226
General Information	227
Storage	229
Preparation for installation	230
Installation	231
Pump fixing	232
Use	234
Switching on and Use of TV 1001 Navigator	235
TV 1001 Navigator Switching off	236
Emergency Stop	236
Maintenance	237
Disposal	238

Original Instructions



Safety Guideline for Turbomolecular Pumps

Turbomolecular pumps as described in the following operating manual contain a large amount of kinetic energy due to the high rotational speed in combination with the specific mass of their rotors.

In case of a malfunction of the system for example rotor/stator contact or even a rotor crash the rotational energy may be released.

WARNING!



To avoid damage to equipment and to prevent injuries to operating personnel the installation instructions as given in this manual should be strictly followed!

General Information

This equipment is destined for use by professionals. The user should read this instruction manual and any other additional information supplied by Agilent before operating the equipment. Agilent will not be held responsible for any events occurring due to non-compliance, even partial, with these instructions, improper use by untrained persons, non-authorized interference with the equipment or any action contrary to that provided for by specific national standards.

The TV 1001 Navigator is an integrated system with a turbo-molecular pump for high and ultra-high vacuum applications with its relevant controller. The system can pump any type of gas or gas compound. It is not suitable for pumping liquids or solid particles. The pumping action is obtained through a high speed turbine (max. 38000 rpm) driven by a high-performance 3-phase electric motor. The TV 1001 Navigator is free of contaminating agents and, therefore, is suitable for applications requiring a "clean" vacuum.

It is equipped with auxiliary connectors to supply an additional fan, to control the vent valve, to be controlled from a remote site by means of a host computer connected through a serial line (RS232 or RS485).

The following paragraphs contain all the information necessary to guarantee the safety of the operator when using the equipment. Detailed information is supplied in the appendix "Technical Information".

16 Instructions for Use

General Information

This manual uses the following standard protocol:

CAUTION!

The caution messages are displayed before procedures which, if not followed, could cause damage to the equipment.

WARNING!



The warning messages are for attracting the attention of the operator to a particular procedure or practice which, if not followed correctly, could lead to serious injury.

NOTE

The notes contain important information taken from the text.

Storage

In order to guarantee the maximum level of performance and reliability of Agilent Turbomolecular pumps, the following guidelines must be followed:

- when shipping, moving and storing pumps, the following environmental specifications should not be exceeded:
 - temperature range: -20 °C to 70 °C
 - relative humidity range: 0 to 95 % (non condensing)
- the turbomolecular pumps must be always soft-started when received and operated for the first time by the customer
- the shelf life of a turbomolecular pump is 10 months from the shipping date.

CAUTION!

If for any reason the shelf life time is exceeded, the pump has to be returned to the factory. Please contact the local Agilent Vacuum Sales and Service representative for informations.

Preparation for installation

The TV 1001 Navigator is supplied in a special protective packing. If this shows signs of damage which may have occurred during transport, contact your local sales office.

When unpacking the system, be sure not to drop it and avoid any kind of sudden impact or shock vibration to it.

Do not dispose of the packing materials in an unauthorized manner. The material is 100 % recyclable and complies with EEC Directive 85/399.

CAUTION!

In order to prevent outgassing problems, do not use bare hands to handle components which will be exposed to vacuum. Always use gloves or other appropriate protection.

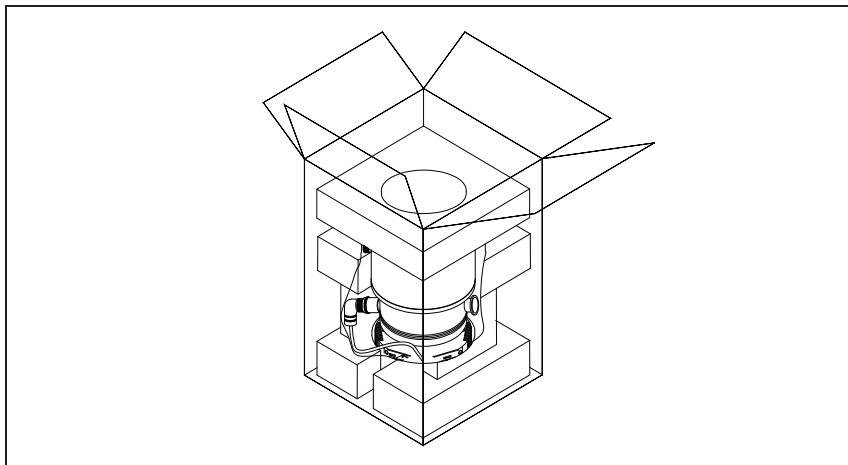

Figure 1

NOTE

Normal exposure to the environment cannot damage the TV 1001 Navigator. Nevertheless, it is advisable to keep it closed until it is installed in the system, thus preventing any form of pollution by dust.

Installation

Do not install or use the pump in an environment exposed to atmospheric agents (rain, snow, ice), dust, aggressive gases, or in explosive environments or those with a high fire risk.

During operation, the following environmental conditions must be respected:

- maximum pressure: 2 bar above atmospheric pressure
- temperature: from +5 °C to +35 °C (see the diagram pressure-temperature in the appendix "Technical Information")
- relative humidity: 0 - 95 % (non-condensing)

CAUTION!

Do not remove the adhesive and protective cap before connecting the turbopump to the system.

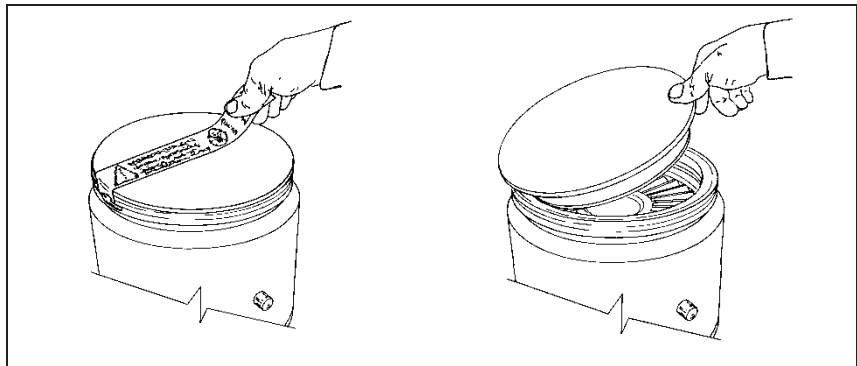

Figure 2

In the presence of magnetic fields the pump must be protected using a ferromagnetic shield. See the appendix "Technical Information" for detailed information.

The TV 1001 Navigator must be connected to a primary pump (see "Technical Information").

Pump fixing

WARNING!



If a rotor failure occurs, the connection of the pump to the system could be subjected to a significant torque. If the connection is not sufficient to withstand that torque, the pump could detach from the system or the motor housing could detach from the pump envelope. In this case metal fragments could be projected from the pump or system, which could cause serious injury or death and/or damage to surrounding equipment.

Fix the TV 1001 Navigator in a stable position mounting the inlet flange of the turbopump to the system counter-flange, with a connection capable of withstanding a torque of 8900 Nm around its axis.

For example the ISO-K flange can be fixed using high strength steel clamps (like Agilent model IC63250DCMZ).

The following table shows, for each flange, the necessary number of IC63250DCMZ clamps and the relevant fixing torque.

Tab. 1

FLANGE	N.	FIXING TORQUE
ISO 160	10	35 Nm
ISO 200	8	35 Nm
ISO 250	6	35 Nm

The following table shows, for each ISO-F flange, the necessary number of screws and the relevant fixing torque.

Tab. 2

FLANGE	N.	FIXING TORQUE
ISO 200 F	12	5 Nm
ISO 250 F	12	5 Nm

The class of the steel screws for "F" flange must be > 8.8

The turbopump with ConFlat inlet flange must be fixed to the vacuum chamber by means of the appropriate Agilent hardware. See the appendix "Technical Information" for a detailed description.

The TV 1001 Navigator can be installed in any position.

NOTE

The TV 1001 Navigator cannot be fixed by means of its base.

CAUTION!

The TV 1001 Navigator belongs to the second installation (or overvoltage) category as per directive EN 61010-1. Connect the device to a mains line that satisfy the above category.

The TV 1001 Navigator has Input/Output and serial communication connectors that must be connected to external circuits in such a way that no electrical part is accessible.

Be sure that the insulation of the device connected to the TV 1001 Navigator is adequate even in the case of single fault as per directive EN 61010-1.

Use

This paragraph details the fundamental operating procedures.

Make all electrical and pneumatic connections before the use of the system.

While heating the vacuum chamber, the temperature of the inlet flange must not exceed 120 °C.

WARNING!

Never use the turbopump when the inlet flange is not connected to the vacuum chamber. Do not touch the turbopump or any of its accessories during the heating process. The high temperatures may cause burns.

CAUTION!

Avoid impacts, oscillations or harsh movements of the pump when in operation. The bearings may become dam-aged. Use air or inert gas free from dust or particles for venting the pump. The pressure at the vent port must be less than 2 bar (above atmospheric pressure). For pumping aggressive gases, these pumps are fitted with a special port to allow a steady flow of inert gas (like N₂, Ar) for pump bearing protection (see the appendix "Technical Information").

WARNING!

When employing the pump for pumping toxic, flammable, or radioactive gases, please follow the required procedures for each gas disposal. Do not use the pump in presence of explosive gases.

Switching on and Use of TV 1001 Navigator

To switch on the TV 1001 Navigator it is necessary to supply the mains. The integrated controller automatically recognizes the interlock and start signals presence and start up the pump.

“Soft Start” mode is used to start the pump after it has stopped for a long time. To start with the “Soft Start” function on, activate the mode in the software (see paragraph “RS 232/485 COMMUNICATION DESCRIPTION” in the “Technical Information” appendix).

The green LED located on the TV 1001 Navigator base front panel indicates with its flashing frequency the system operating conditions:

- with no flashing: the pump is normally rotating;
- slowly flashing (period of about 400 ms): the system is in ramp, or in braking, or in Stop, or in “Waiting for interlock” status;
- fast flashing (period of about 200 ms): error condition.

TV 1001 Navigator Switching off

To switch off the TV 1001 Navigator it is necessary to re-move the mains. The integrated controller immediately stops the pump.

WARNING!



The Turbo-V controller must be powered with 3-wire power cord (see orderable parts table) and plug (internationally approved) for user's safety. Use this power cord and plug in conjunction with a properly grounded power socket to avoid electrical shock and to satisfy CE requirements. High voltage developed in the controller can cause severe injury or death. Before servicing the unit, disconnect the input power cable.

Emergency Stop

To immediately stop the TV 1001 Navigator in an emergency condition it is necessary to remove the supply cable from the mains plug.

Maintenance

The TV 1001 Navigator does not require any maintenance. Any work performed on the system must be carried out by authorized personnel.

WARNING!



Before carrying out any work on the system, disconnect it from the mains, vent the pump by opening the appropriate valve, wait until the rotor has stopped turning and wait until the surface temperature of the pump falls below 50 °C.

In the case of breakdown, contact your local Agilent service center who can supply a reconditioned pump to replace that broken down.

NOTE

Before returning the pump to the constructor for repairs, or advanced exchange service, the "Health and Safety" sheet attached to this instruction manual must be filled-in and sent to the local sales office. A copy of the sheet must be inserted in the system package before shipping.

If a pump is to be scrapped, it must be disposed of in accordance with the specific national standards.

Disposal

Meaning of the "WEEE" logo found in labels The following symbol is applied in accordance with the EC WEEE (Waste Electrical and Electronic Equipment) Directive. This symbol (**valid only in countries of the European Community**) indicates that the product it applies to must NOT be disposed of together with ordinary domestic or industrial waste but must be sent to a differentiated waste collection system. The end user is therefore invited to contact the supplier of the device, whether the Parent Company or a retailer, to initiate the collection and disposal process after checking the contractual terms and conditions of sale.





17 Technical Information

Description of the TV 1001 Navigator	241
Pump Description	245
Controller Description	247
Technical Specification	248
TV 1001 Navigator Outline	250
Interconnections	254
P3 - Vent	255
P4 – External Fan	255
J1 – In-Out	256
Signal Description	257
HOW to Connect the Open-Collector Inputs of the Controller	260
How to Connect the Outputs of the Controller	264
J2 – Serial	265
RS 232/RS 485 Communication Description	266
Communication Format	266
Communication Protocol	266
Window-Meanings	271
Inlet Screen Installation	275
Heater Band Installation	278

Original Instructions



Air Cooling Kit Installation	280
TV 1001 with Navigator Controller	280
TV 1001 Pump with Standard Rack Controller	282
Water Cooling Kit Installation	284
Vent Accessories	287
TV 1001 Navigator Controller Compatible Vent Valve mod. 969-9834	287
Standard Rack Controller Compatible Vent Valve mod. 969-9843	289
Vent Device mod. 969-9831	290
Vibration Isolator Installation	291
Purge Valve Installation	292
Serial Cable Installation	293
TV 1001 Controller Installation	294
Bottom Mounting	294
Side Mounting	296
Connection A - High Vacuum Flange	298
Connection B - Fore-Vacuum Pump	300
Connection C – Electrical	300
Pump Used with Corrosive Gases	302
Pump Used in Presence of Magnetic Fields	304
Accessories and Spare Parts	305

Description of the TV 1001 Navigator

The TV 1001 Navigator pumping system consists of a pump with a dedicated controller fixed to it. The system is available in six models that differ in the high vacuum flange.

The TV 1001 Navigator kit six models are:

- Model 969-8838 with ISO 200 high vacuum flange;
- Model 969-8844 with ISO 200 F high vacuum flange;
- Model 969-8839 with ConFlat 10" external di-iameter high vacuum flange;
- Model 969-8840 with ISO 160 high vacuum flange;
- Model 969-8841 with ISO 250 high vacuum flange;
- Model 969-8845 with ISO 250 F high vacuum flange.

17 Technical Information
Description of the TV 1001 Navigator

The following figure shows the six models.

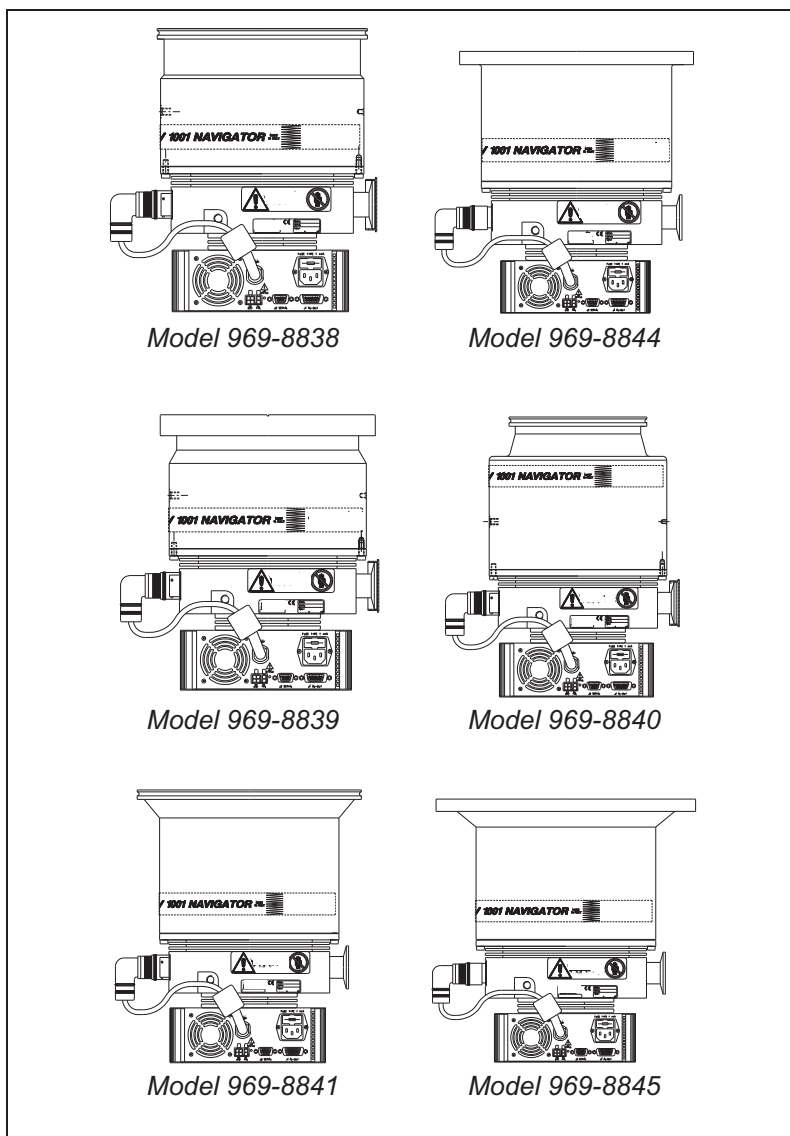

Figure 1

The pumps only are available with the following models:

- Model 969-8931 with ISO 200 high vacuum flange;
- Model 969-8946 with ISO 200 F high vacuum flange;
- Model 969-8932 with ConFlat 10" external di-iameter high vacuum flange;
- Model 969-8933 with ISO 160 high vacuum flange;
- Model 969-8934 with ISO 250 high vacuum flange;
- Model 969-8947 with ISO 250 F high vacuum flange.

17 Technical Information
Description of the TV 1001 Navigator

The following figure shows the six models.

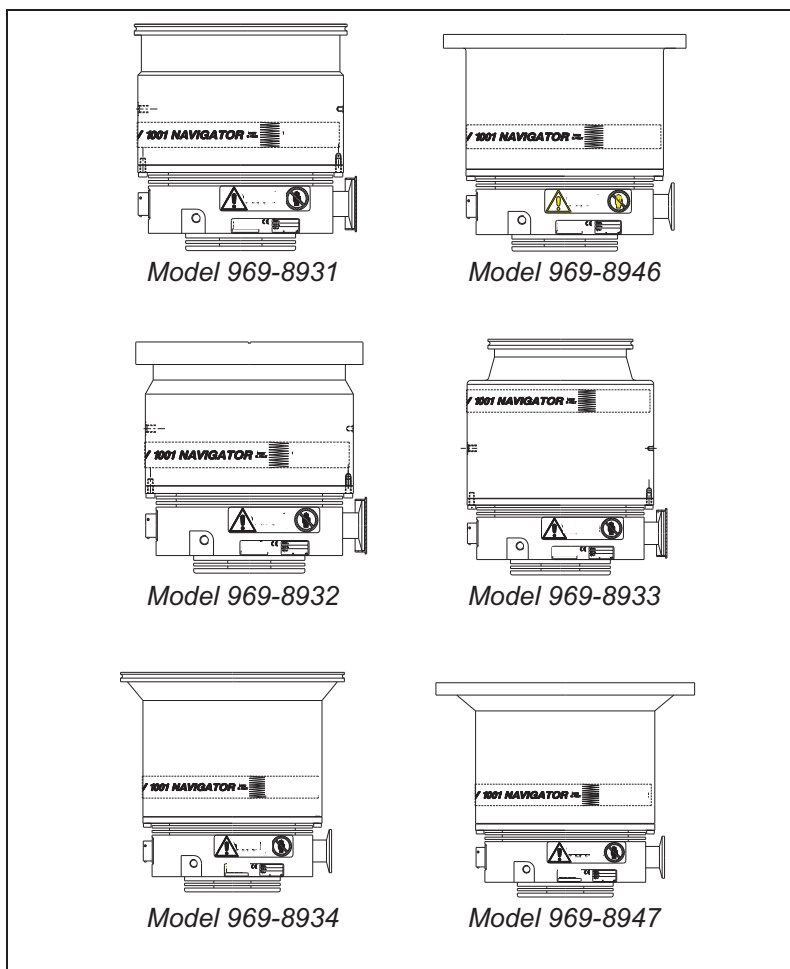

Figure 2

The controller model 969-8978 is also available as an option.

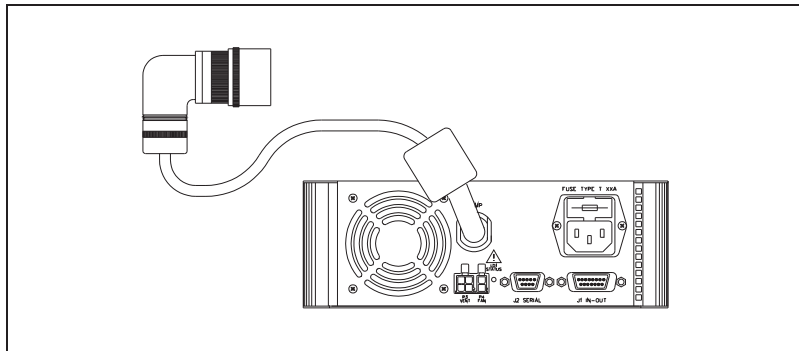

Figure 3 Controller model 969-8978

Pump Description

The pump consists of a high frequency motor driving a turbine fitted with 8 bladed stages and 4 Macrotorr stages. The turbine rotates in an anticlockwise direction when viewed from the high vacuum flange end.

The turbine is made of high-strength aluminium alloy, machined from a single block.

Proceeding from the high vacuum to the for vacuum region, the turbine stages sequence is:

- 1st stage with a blade angle of 40°,
- 2nd stage with a blade angle of 34°,
- 3rd stage with a blade angle of 28°,
- 4th and 5th stages with a blade angle of 24°,
- 6th stage with a blade angle of 20°,
- 7th and 8th stages with a blade angle of 16°.

The Macrotorr stages are in the form of four discs.

17 Technical Information

Description of the TV 1001 Navigator

The turbine rotor is supported by permanently lubricated high precision ceramic ball bearings in-stalled on the forevacuum side of the pump.

The static blades of the stator are made of stainless steel. These are supported and accurately po-sitioned by spacer rings.

The Macrotrorr stators are in the form of self-positioning machined discs with pumping channels and an opening restricted by the corresponding rotor discs. These are made of aluminium alloy.

During normal operation, the motor is fed with a voltage of 54 Vac three-phase at 715 Hz. To re-duce losses during start-up to a minimum, the frequency increases according to a ramp with a higher initial voltage/frequency ratio.

The pump can be water cooled or air cooled: in the first case the customer can use the dedicated channels on the pump body, in the second case an external optional fan is available.

A thermistor sensor is mounted near the upper bearing to prevent the pump from overheating.

The pump is balanced after assembly with a resid-ual vibration amplitude less than 0.01 μm .

The pump can operate in any position and can be supported on the high vacuum flange. The connection of the forevacuum on the side of the pump is a KF 40 NW flange.

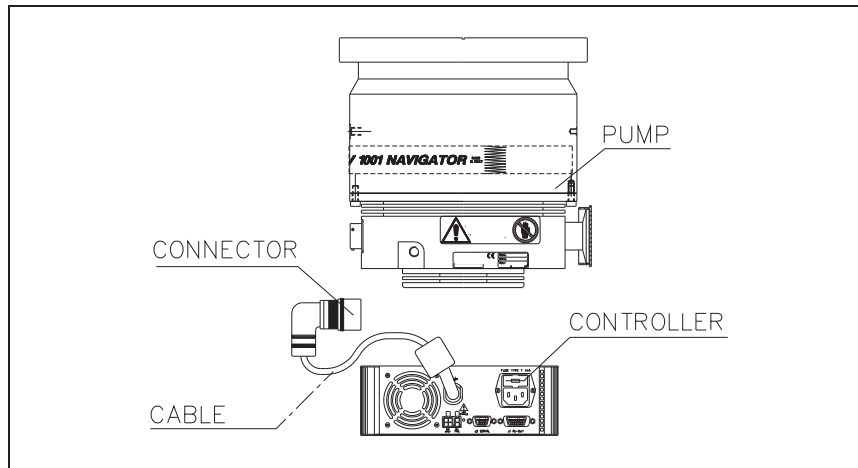

Figure 4

Controller Description

The dedicated controller is a solid-state frequency converter which is driven by a single chip micro-computer and is composed of two PCBs which include power supply and 3-phase output, analog and input/output section, microprocessor and digital section.

The power supply, together with the 3-phase out-put, converts the single phase AC mains supply into a 3-phase, low voltage, medium frequency output which is required to power the pump.

The controller can be operated by a remote host computer via the serial connection. A Windows-based software is available (optional).

Technical Specification

Tab. 3

Pumping speed (with inlet screen)	ISO 160:	CFF 10"/ ISO 200:	ISO 250:
N ₂ :	790 l/s	950 l/s	1050 l/s
He:	820 l/s	870 l/s	900 l/s
H ₂ :	860 l/s	900 l/s	920 l/s
Compression ratio			
N ₂ :	>1 x 10 ⁹	1 x 10 ⁹	
He:	5 x 10 ⁷	1 x 10 ⁷	
H ₂ :	2 x 10 ⁶	1 x 10 ⁶	
Base pressure with recommended forepump	< 1 x 10 ⁻¹⁰ mbar (< 1 x 10 ⁻¹⁰ Torr) (According to standard DIN 28 428, the base pressure is that measured in a leak-free test dome, 48 hours after the completion of test dome bake-out, with a Turbopump fitted with a ConFlat flange and using the recommended pre-vacuum pump)		
Inlet flange	ISO 160, ISO 200, ISO 250 CF 10"		
Foreline flange	KF 40 NW		
Rotational speed	38000 rpm		
Start-up time	< 4 minutes		
Recommended forepump	DS 402, TriScroll 300		
Operating position	Any		
Operating ambient temperature	+5 °C to +35 °C		
Bakeout temperature	120 °C at inlet flange max. (CF flange) 80 °C at inlet flange max. (ISO flange)		
Vibration level (displacement)	< 0.01 µm at inlet flange		
Lubricant	permanent lubrication		
Cooling requirements	Forced air or water		
Coolant water	Minimum flow: 200 l/h (0.89 GPM) Temperature: +10 °C to +20 °C Pressure: 3 to 5 bar (45 to 75 psi)		
Noise level	<45 dB(A) at 1 meter		

Power supply:	
Input voltage:	100 - 240 Vac
Input freq.:	50 - 60 Hz
Max input power:	600 VA
Stand-by power:	30 to 35 W
Max operating power:	450 W with water cooling 300 W with air cooling
Protection fuse	1 x 6.3 A
Compliance with:	UNI EN 292-1 UNI EN 292-2 EN-CENELEC 55011 IEC 1000-4-2 (ex 801-2) IEC 1000-4-3 (ex 801-3) IEC 1000-4-4 (ex 801-4) EN 61010-1 (IEC 1010-1) EN 1012-2
Power cable	With European or NEMA plug 3 meters long (optional)
Serial communication (Navigator kit)	RS232 cable with a 9-pin D type male connector and a 9-pin D type female connector, and Navigator software (optional)
Installation category	II
Pollution degree	2
Storage temperature	-20 °C to +70 °C
Weight kg (lbs)	
ISO 160 flange	19 (41.8)
ISO 200 flange	19.4 (43)
ISO 250 flange	21.2 (46.6)
CF 10" flange	25.5 (54.2)
Controller	5.4 (12)

NOTE

When the TV 1001 Navigator has been stored at a temperature less than 5 °C, wait until the system has reached the above mentioned temperature.

TV 1001 Navigator Outline

The following figures show the TV 1001 Navigator outlines (dimensions are in mm [inches]).

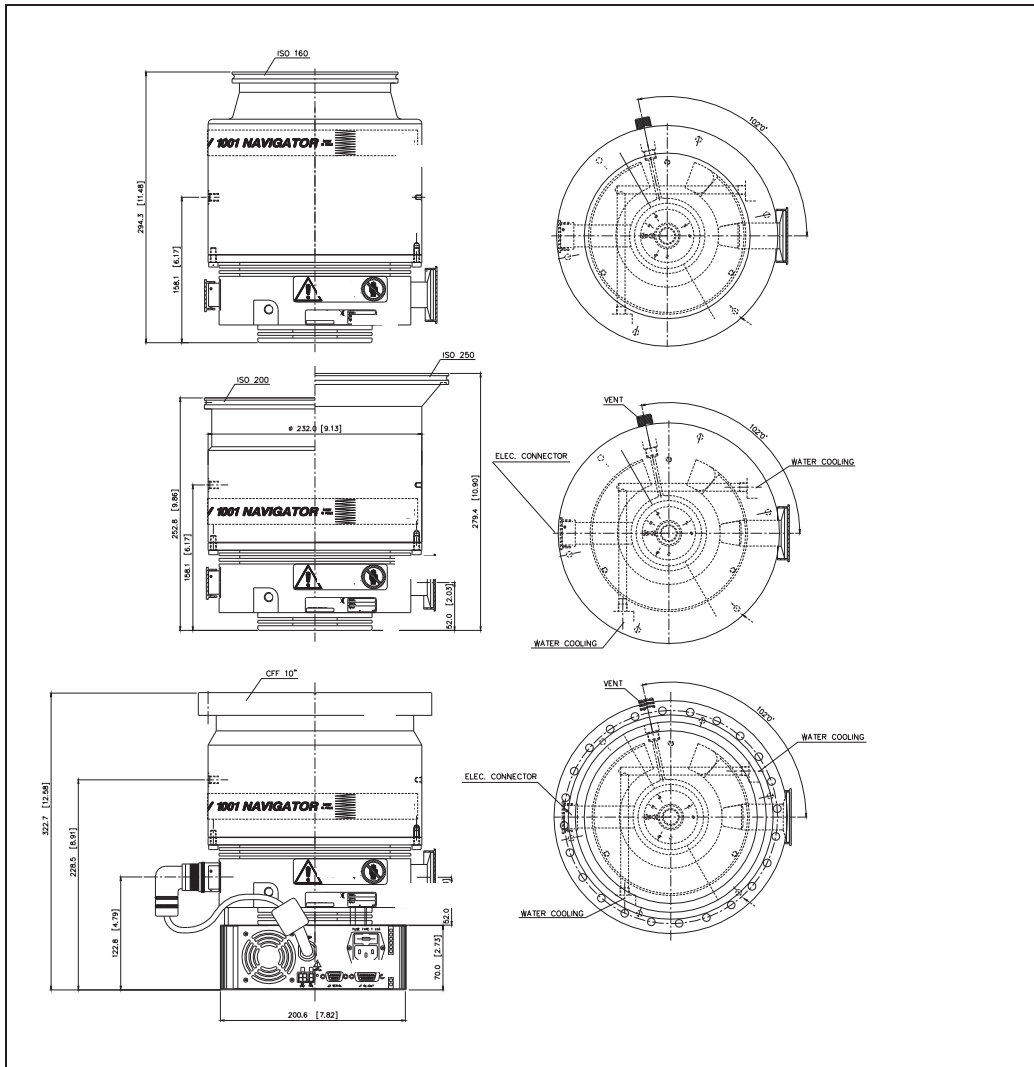

Figure 5

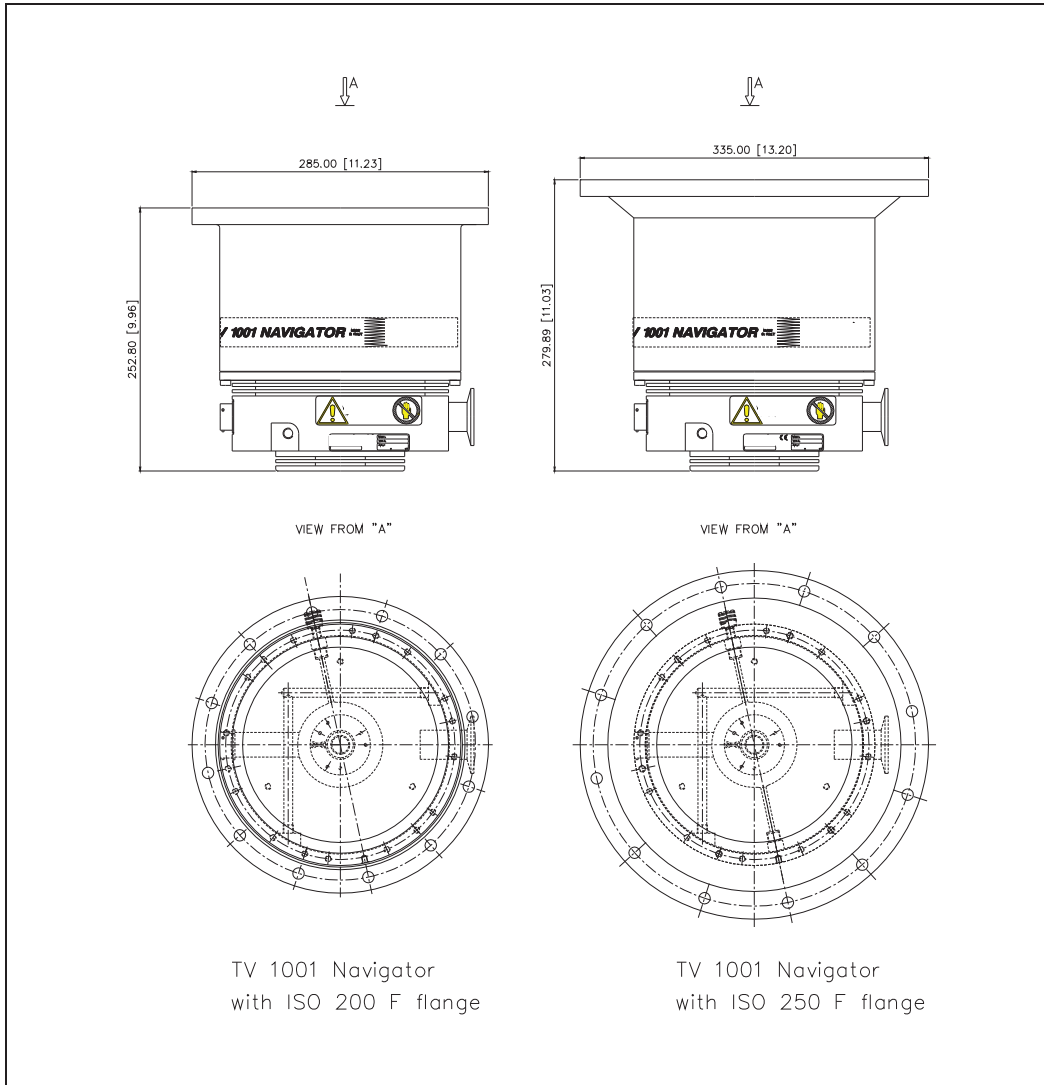

Figure 6

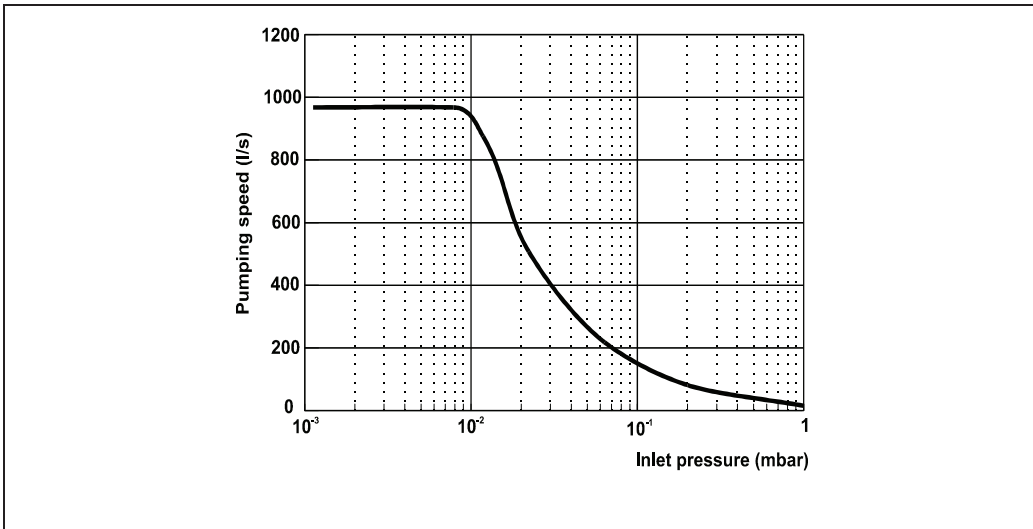

Figure 7 Graph of nitrogen pumping speed vs inlet pressure

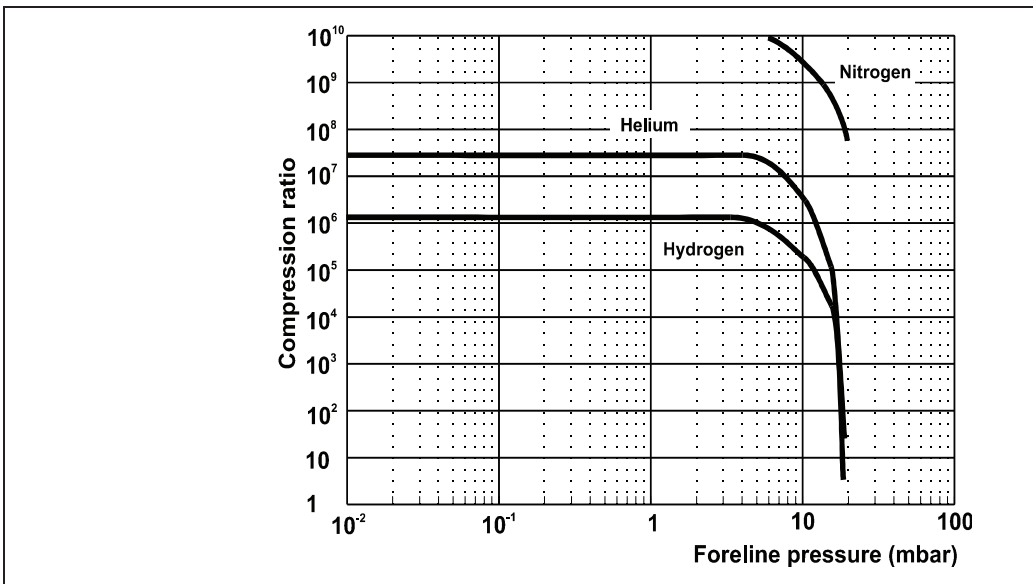

Figure 8 Graph of compression ratio vs foreline pressure

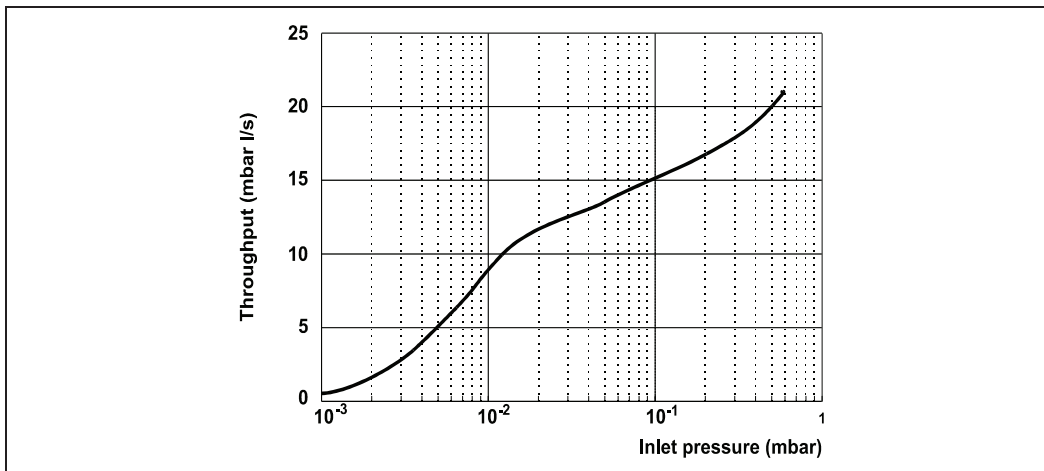

Figure 9 Graph of nitrogen throughput vs inlet pressure using the recommended mechanical forevacuum pump

Interconnections

The following figure shows the TV 1001 interconnections.

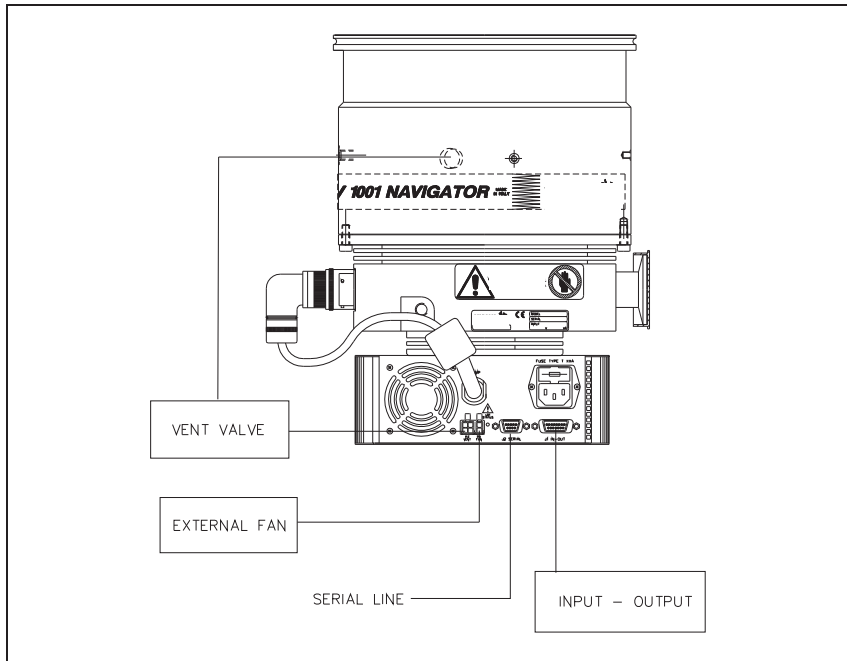

Figure 10

P3 - Vent

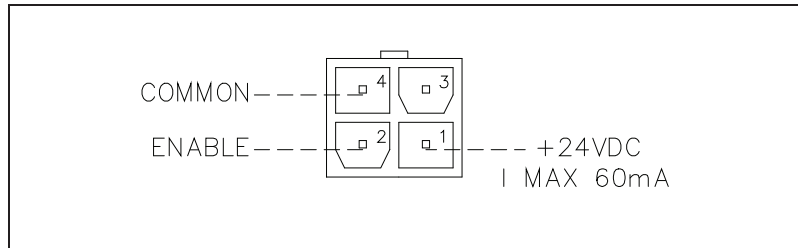

Figure 11

This is a dedicated 24 Vdc connector to control the optional vent valve.

P4 – External Fan

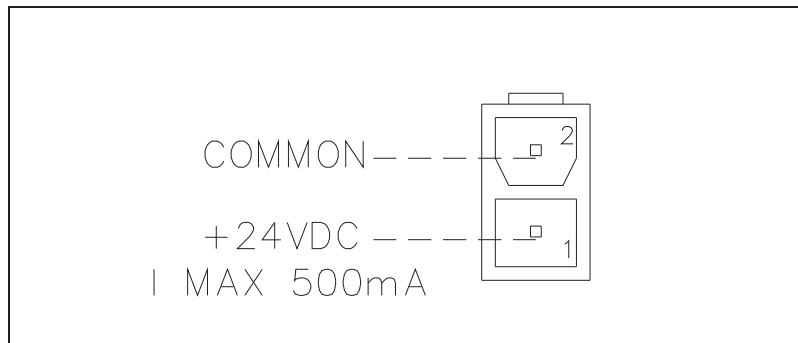

Figure 12

This is a dedicated 24 Vdc connector to supply the optional external fan.

J1 – In-Out

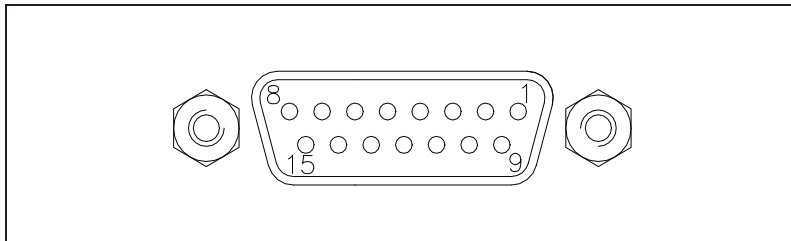

Figure 13

This connector carries all the input and output signals to remote control the TV 1001 Navigator.

It is a 15-pins D type connector; the available signals are detailed in the table, the following paragraphs describe the signal characteristics and use.

Tab. 4

Pin N.	Signal name	In-/Output
1	START/STOP (+)	IN
2	START/STOP (-)	IN
3	INTERLOCK (+)	IN
4	INTERLOCK (-)	IN
5	SPEED SETTING (+)	IN
6	SPEED SETTING (-)	IN
7	SOFT START (+)	IN
8	SOFT START (-)	IN
9	+24 Vdc	OUT
10	SPARE	
11	PROGRAMMABLE SET POINT	OUT
12	SPARE	
13	FAULT OUTPUT	OUT
14	PROGRAMMABLE ANALOG SIGNAL (+)	OUT
15	<ul style="list-style-type: none"> ▪ GROUND ▪ PROGRAMMABLE ANALOG SIGNAL (-) 	OUT

Signal Description

Start/Stop: input signal to start or stop the pump. With the supplied cover connector the START/STOP (+) signal is connected to the +24 Vdc pin and the START/STOP (-) signal to the GROUND pin: in this condition the pump automatically starts as soon as the controller recognises the input supply ("Plug & Pump").

Interlock: input signal to control the pump rotation. With the supplied cover connector the interlock (+) signal is connected to the +24 Vdc pin and the interlock (-) signal to the GROUND pin.

Speed setting: PWM input signal to set the pump speed. The PWM signal characteristics must be the following:

- frequency: 100 Hz +/-20 %
- amplitude: 24 V max
- duty cycle range: from 25 % to 75 %
- corresponding to an output frequency from 272 Hz to 633 Hz (see the following diagram):

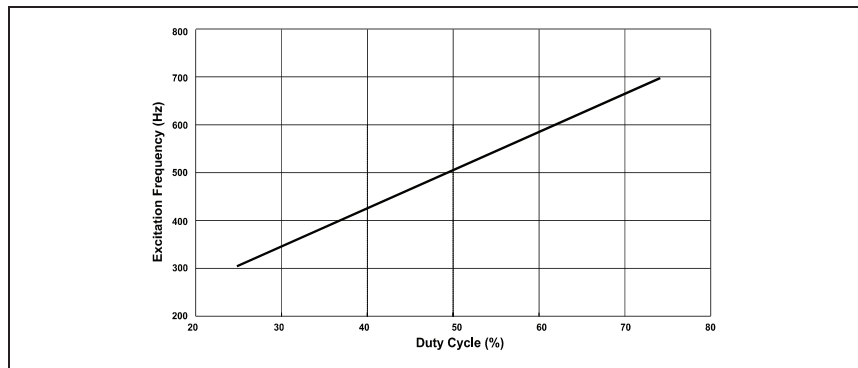

Figure 14

NOTE

The duty cycle percentage is referred to the low level portion of the PWM signal

Programmable analog signal: this output signal is a voltage (from 0 to 10 Vdc) proportional to a reference quantity (frequency or power) set by the user. The default setting is the frequency (see the following example diagram).

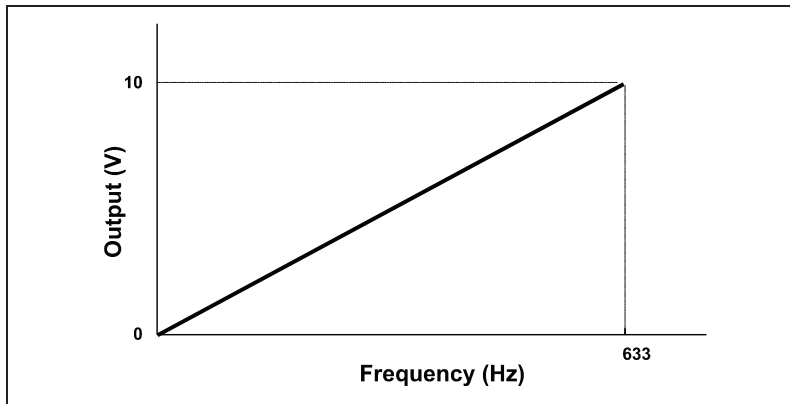

Figure 15

Fault: this open collector output signal is ON when a system fault condition is detected.

Programmable set point: this open collector output signal is enabled when the reference quantity chosen (frequency, current or time) is higher than the set threshold. The signal can be "high level active" (that is the output is normally at 0 Vdc and becomes 24 Vdc when activated), or "low level active" (that is the output is normally at 24 Vdc and becomes 0 Vdc when activated). Moreover, if the reference quantity is the frequency or the current drawn, it is possible to set the hysteresis (in % of the threshold value) to avoid bouncing.

For example:

- reference quantity: frequency
- threshold: 500 Hz
- hysteresis: 1 %
- activation type: "high level"

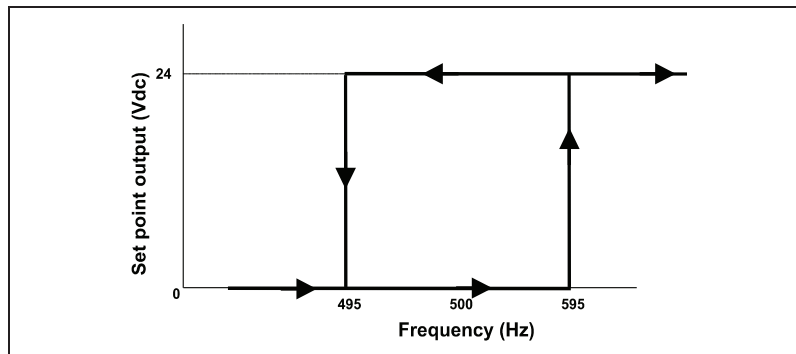

Figure 16

The set point output stays at 0 Vdc until the frequency becomes higher than 505 Hz (that is 500 Hz + 1 % of 500 Hz), then the output goes at 24 Vdc and stays at 24 Vdc until the frequency becomes lower than 495 Hz (that is 500 Hz - 1 % of 500 Hz).

It is possible to delay the set point checking for a programmable delay time.

The PROGRAMMABLE SET POINT signal has the following default settings:

- reference quantity: frequency
- threshold: 643 Hz
- hysteresis: 2 %
- activation type: high level
- delay time: 0 second

NOTE

The Navigator Software (optional) allows the operator to set all the programmable feature.

When no external input-output device is available this connector must be closed with the supplied mating connector that short-circuits the START and INTERLOCK inputs with the GROUND input (see the following figure).

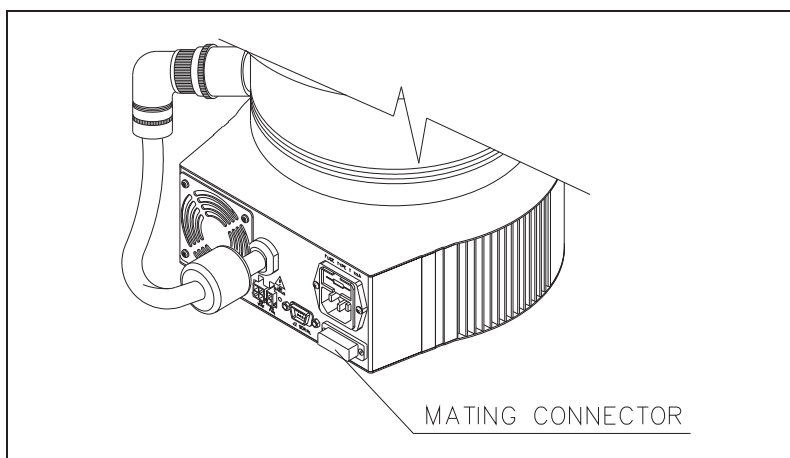

Figure 17

How to Connect the Open-Collector Inputs of the Controller

Here below there are the typical connections of the open collector input of TV551/701 Navigator to an external system. Two cases are considered:

1. the customer supplies the 24 Vdc
2. the customer does not supply the 24 Vdc.

Please note that on the connector a 24 Vdc, 60 mA voltage, a GROUND signal and the open collector pin are available.

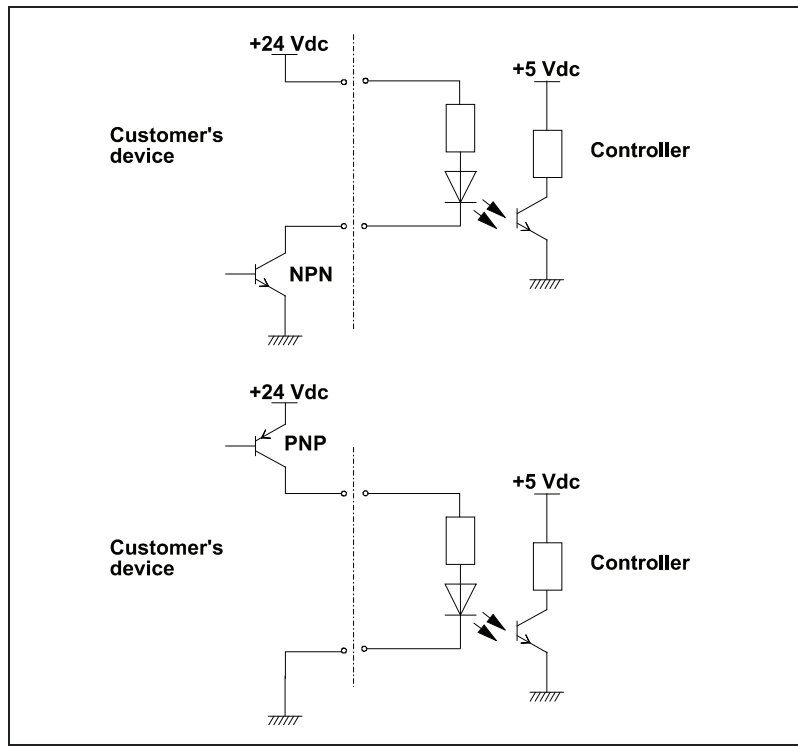

Figure 18 Case 1

17 Technical Information
Interconnections

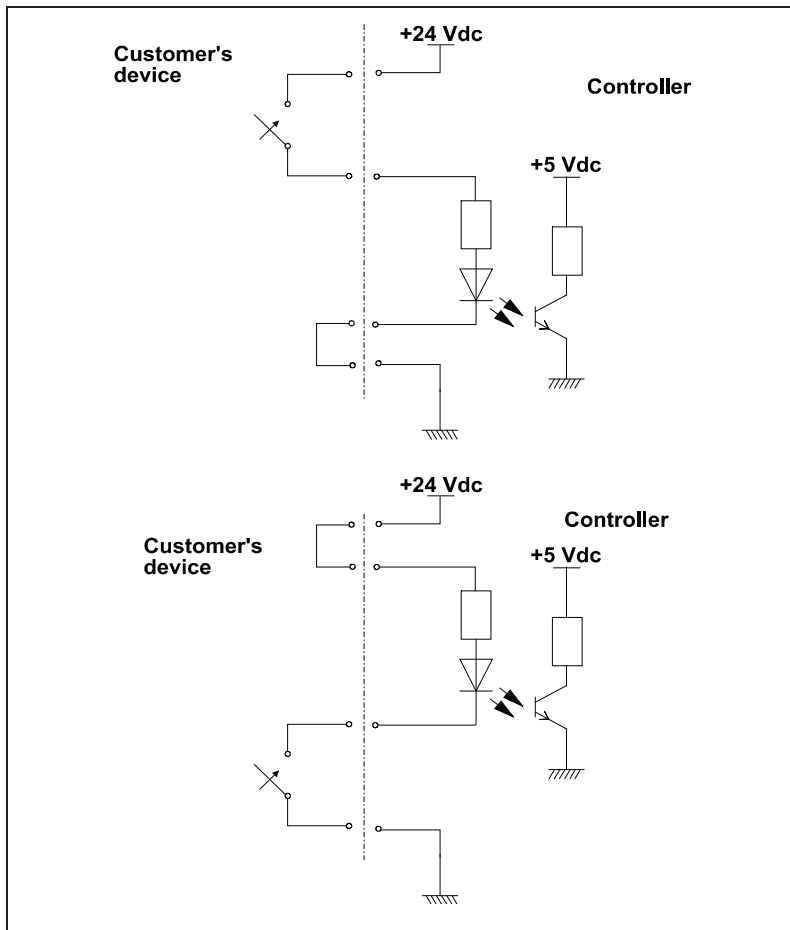

Figure 19 Case 2 with relay utilisation

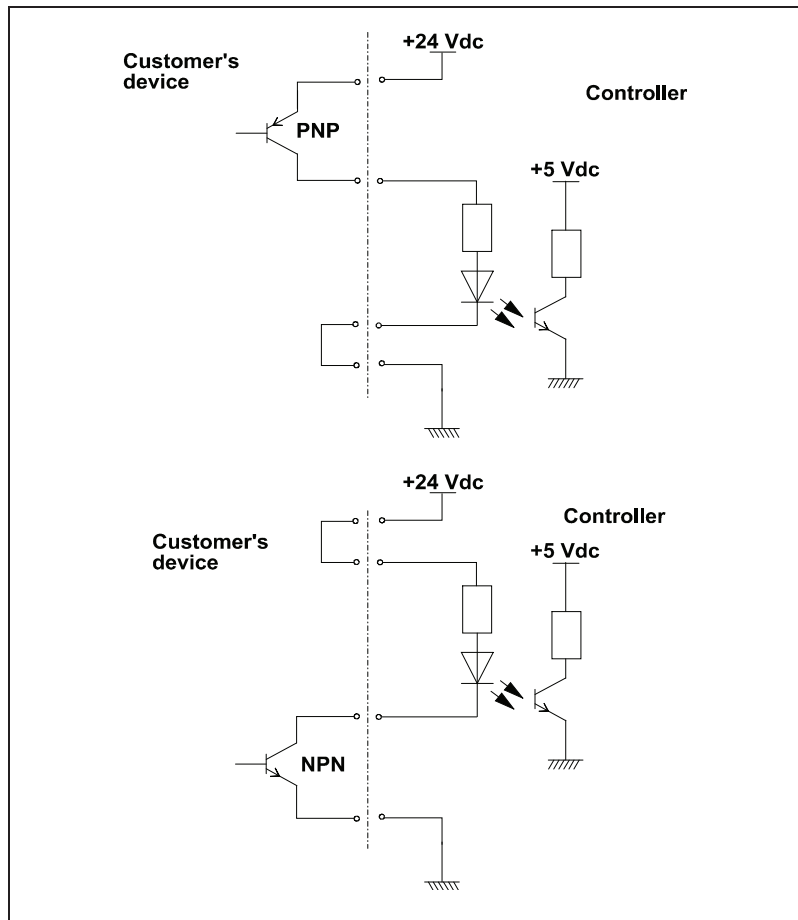

Figure 20 Case 2 with transistor utilization

How to Connect the Outputs of the Controller

The following figure shows a typical logic output connection (relay coil) but any other device may be connected e.g. a LED, a computer, etc., and the related simplified circuit of the controller. The figure example refers to the programmable set point signal on pins 11 and 9.

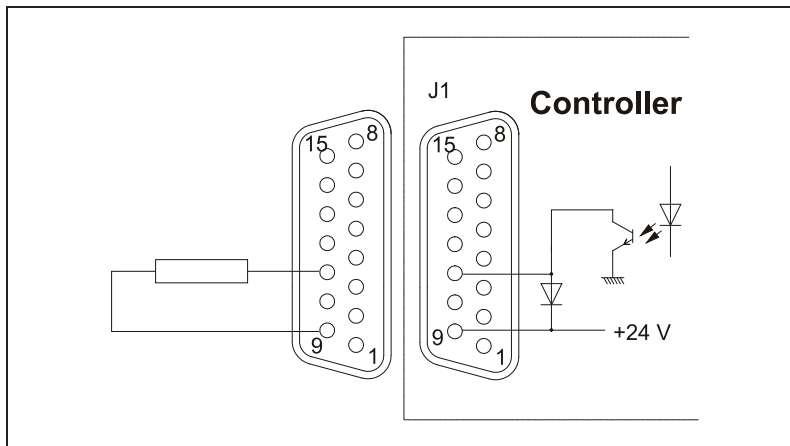

Figure 21 Typical output connection

J2 – Serial

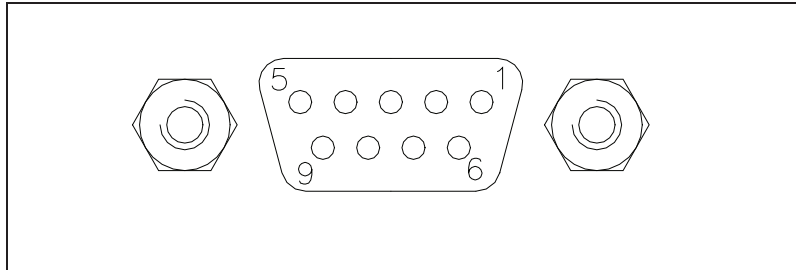

Figure 22 Typical output connection

This is a 9 pin D-type serial input/output connector to control via an RS 232 or RS 485 connection the TV 1001.

Tab. 5

Pin N.	Signal name
1	SPARE
2	TX (RS232)
3	RX (RS232)
4	SPARE
5	GND
6	A + (RS485)
7	SPARE
8	B – (RS485)
9	RESERVED

Note that the vent valve can also be controlled by means of the serial connection.

A serial communication kit with a serial cable and the T-Plus software is available (optional).

RS 232/RS 485 Communication Description

Both the RS 232 and the RS 485 interfaces are available on the connector J2.

The communication protocol is the same (see the structure below), but only the RS 485 manages the address field. Therefore to enable the RS 485 is necessary to select the type of communication as well as the device address by means of the Navigator software.

Communication Format

- 8 data bit
- no parity
- 1 stop bit
- baud rate: 600/1200/2400/4800/9600 programmable

Communication Protocol

The communication protocol is a MASTER/SLAVE type where:

- Host = MASTER
- Controller = SLAVE

The communication is performed in the following way:

1. the host (MASTER) send a MESSAGE + CRC to the controller (SLAVE);
2. the controller answer with an ANSWER + CRC to the host.

The MESSAGE is a string with the following format:

<STX>+<ADDR>+<WIN>+<COM>+<DATA>+<ETX>+<CRC>

where:

NOTE

When a data is indicated between two quotes ('...') it means that the indicated data is the corresponding ASCII character.

- <STX> (Start of transmission) = 0x02
- <ADDR> (Unit address) = 0x80 (for RS 232)
- <ADDR> (Unit address) = 0x80 + device number (0 to 31) (for RS 485)
- <WIN> (Window) = a string of 3 numeric character indicating the window number (from '000' to '999'); for the meaning of each window see the relevant paragraph.
- <COM> (Command) = 0x30 to read the window, 0x31 to write into the window
- <DATA> = an alphanumeric ASCII string with the data to be written into the window. In case of a reading command this field is not present

The field length is variable according to the data type as per the following table:

Tab. 6

Data type	Field length	Valid characters
Logic (L)	1	'0' = OFF '1' = ON
Numeric (N)	6	'-', '.', '0' ... '9' right justified with '0'
Alphanumeric (A)	10	from blank to '_' (ASCII)

- <ETX> (End of transmission) = 0x03
- <CRC> = XOR of all characters subsequent to <STX> and including the <ETX> terminator. The value is hexadecimal coded and indicated by two ASCII character.

The addressed SLAVE will respond with an ANSWER whose structure depends from the MESSAGE type.

17 Technical Information

RS 232/RS 485 Communication Description

When the MESSAGE is a reading command, the SLAVE will respond transmitting a string with the same structure of the MESSAGE.

NOTE

Using the RS 485 interface, the message structure remains identical to the one used for the RS 232 interface, the only difference being that the value assigned to the ADDRESS <ADDR>

The controller can answers with the following response types:

Tab. 7

Type	Length	Value	Description
Logic	1 byte	-	After a read instruction of a logic window
Numeric	6 bytes	-	After a read instruction of a numeric window
Alphanumeric	10 bytes	-	After a read instruction of an alphanumeric window
ACK	1 byte	(0x6)	The command execution has been successfully completed
NACK	1 byte	(0x15)	The command execution has been failed
Unknown Window	1 byte	(0x32)	The specified window in the command is not a valid window
Data Type Error	1 byte	(0x33)	The data type specified in the command (Logic, Numeric or Alphanumeric) is not accorded with the specified Window
Out of Range	1 byte	(0x34)	The value expressed during a write command is out of the range value of the specified window
Win Disabled	1 byte	(0x35)	The specified window is Read Only or temporarily disabled (for example you can't write the Soft Start when the Pump is running)

Examples

Command: START

Source: PC

Destination: Controller

02	80	30	30	30	31	31	03	42	33
STX	ADDR	WINDOW			WR	ON	ETX	CRC	

Source: Controller

Destination: PC

02	80	06	03	38	35
STX	ADDR	ACK	ETX	CRC	

Command: STOP

Source: PC

Destination: Controller

02	80	30	30	30	31	30	03	42	32
STX	ADDR	WINDOW			WR	OFF	ETX	CRC	

Source: Controller

Destination: PC

02	80	06	03	38	35
STX	ADDR	ACK	ETX	CRC	

17 Technical Information

RS 232/RS 485 Communication Description

Command: SOFT-START (ON)

Source: PC

Destination: Controller

02	80	31	30	30	31	31	03	42	32
STX	ADDR	WINDOW			WR	ON	ETX	CRC	

Source: Controller

Destination: PC

02	80	06	03	38	35
STX	ADDR	ACK	ETX	CRC	

Command: SOFT-START (OFF)

Source: PC

Destination: Controller

02	80	31	30	30	31	30	03	42	33
STX	ADDR	WINDOW			WR	OFF	ETX	CRC	

Source: Controller

Destination: PC

02	80	06	03	38	35
STX	ADDR	ACK	ETX	CRC	

Window-Meanings

Tab. 8

N.	Read/Write	Datatype	Description	Admitted Values
000	R/W	L	Start/Stop (in remote mode the window is a read only)	Start = 1 Stop = 0
008	R/W	L	Remote (default) or Serial configuration	Remote = 1 Serial = 0 (default = 1)
100	R/W	L	Soft Start (write only in Stop condition)	YES = 1 NO = 0
101	R/W	N	Set Point type	0 = Frequency 1 = Current 2 = Time (default = 0)
102	R/W	N	Set Point threshold (expressed in Hz, mA or s)	(default = 582)
103	R/W	N	Set Point delay: time between the pump start and the set point check (seconds)	0 to 99999 (default = 0)
104	R/W	L	Set Point signal activation type: the signal can be "high level active" or "low level active"	0 = high level active 1 = low level active (default = 0)
105	R/W	N	Set point hysteresis (in % of threshold)	0 to 100 (default = 2)
106	R/W	L	Intercooling	0 = NO 1 = YES
107	R/W	L	Active Stop (write only in stop)	0 = NO 1 = YES

17 Technical Information

RS 232/RS 485 Communication Description

N.	Read/Write	Datatype	Description	Admitted Values
108	R/W	N	Baud rate	600 = 0 1200 = 1 2400 = 2 4800 = 3 9600 = 4 (default = 4)
109	W	L	Pump life/ cycle time/ cycle number reset	To reset write '1'
110	R/W	L	Interlock type (default = 1)	Impulse = 0 Continuous = 1
111	R/W	L	Analog output type: output voltage signal proportional to frequency or power	0 = frequency 1 = power (default = 0)
120	R/W	N	Rotational frequency setting (Hz)	150 to 646 (default = 646)
121	R/W	N	Maximum rotational frequency in Hz (active only in Stop condition)	150 to 646 (default = 646)
122	R/W	L	Set vent valve on/off (on = closed)	On = 1 Off = 0 (default = 1)
123	Reserved to Agilent service			
124				
125	R/W	L	Set the vent valve operation	Automatic = 0 (see note 1.) On command = 1 (see note 2.)
126	R/W	N	Vent valve opening delay (expressed in 0.2 sec)	0 to 65535 (corresponding to 0 to 13107 sec)
130	Reserved to Agilent service			
200	R	N	Pump current in mA dc	
201	R	N	Pump voltage in Vdc	

N.	Read/Write	Datatype	Description	Admitted Values
202	R	N	Pump power in W (pump current x pump voltage duty cycle)	
203	R	N	Driving frequency in Hz	
204	R	N	Pump temperature in °C	0 to 70
205	R	N	Pump status	Stop = 0 Waiting intlk = 1 Starting = 2 Auto-tuning = 3 Braking = 4 Normal = 5 Fail = 6
206	R	N	Error code	Bit description: see the following figure
300	R	N	Cycle time in minutes (zeroed by the reset command)	0 to 999999
301	R	N	Cycle number (zeroed by the reset command)	0 to 9999
302	R	N	Pump life in hours (zeroed by the reset command)	0 to 999999
320 to 399	Reserved to Agilent service			
400	R	A	CRC EPROM (QE)	QE5XXXX (where "XXXX" are variable)
402	R	A	CRC Param. (PA)	PA5XXXX (where "XXXX" are variable)
500	Reserved to Agilent service			
503	R/W	N	RS 485 address	0 to 31 (default = 0)
504	R/W	L	Serial type select	0 = RS 232 1 = RS 485

17 Technical Information

RS 232/RS 485 Communication Description

N.	Read/Write	Datatype	Description	Admitted Values (default = 0)
----	------------	----------	-------------	----------------------------------

NOTE

1. Automatic means that when the controller stops, the vent valve is opened with a delay defined by window n. 126; when the controller starts, the vent valve is immediately closed.

2. On command means that the vent valve is opened or closed by means of window n. 122.

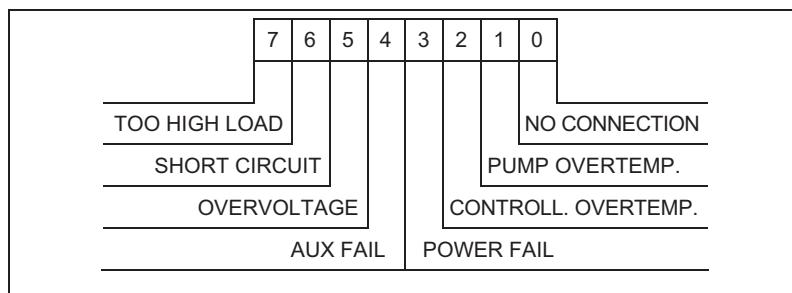

Figure 23 Window N. 206 Bit Description

Inlet Screen Installation

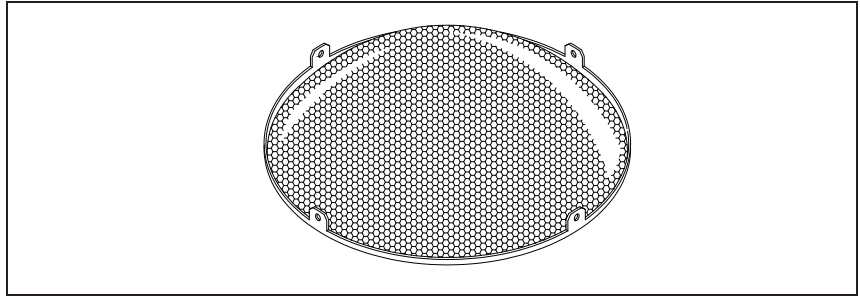

Figure 24

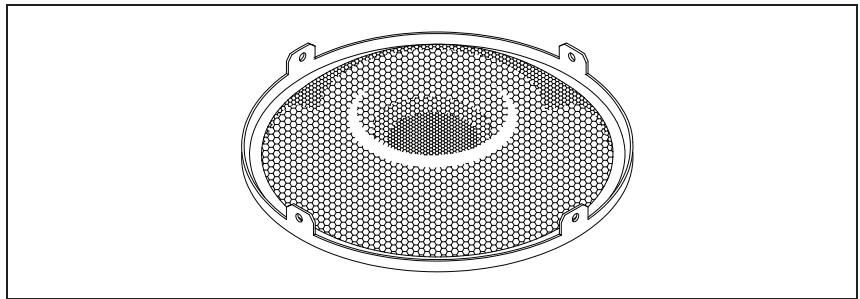

Figure 25

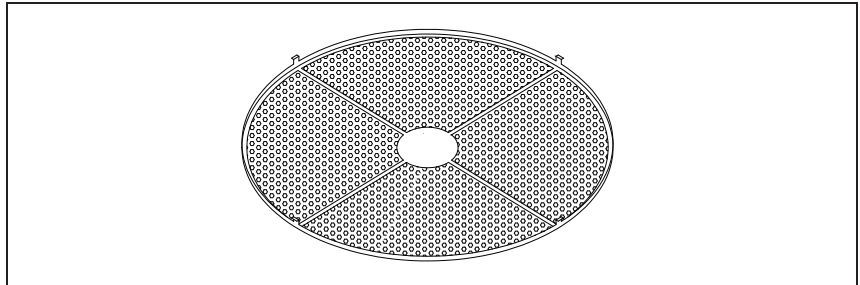

Figure 26

17 Technical Information

Inlet Screen Installation

The inlet screens mod. 969-9304, 969-9316 and 969-9350 prevent the blades of the pump from being damaged by debris greater than 0.7 mm diameter.

The inlet screen, however, does reduce the pumping speed by about 10 %.

The inlet screen is fitted in the upper part of the pump, as shown in the figure.

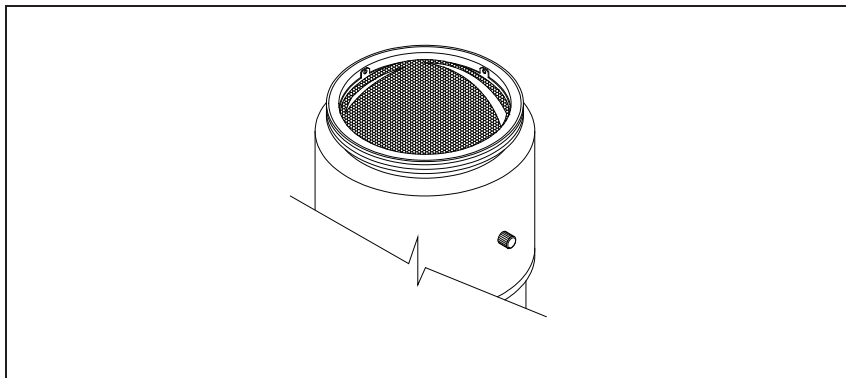

Figure 27

The screen can be mounted on each pump. The screen can be removed as shown in the following figure.

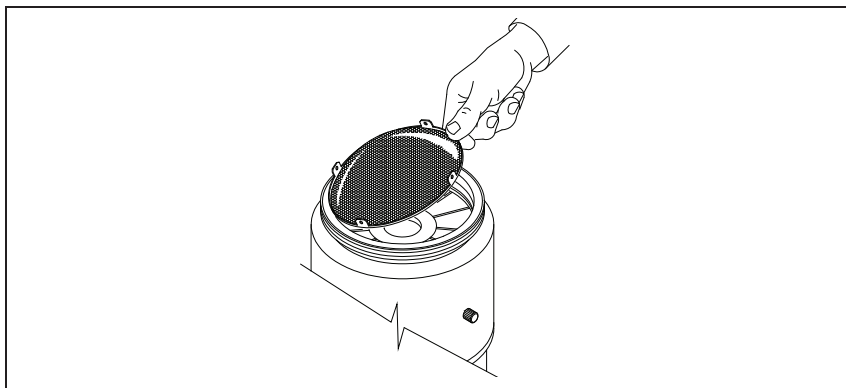

Figure 28

The following figure shows the overall flange di-mensions with the protection screen fitted on pump with ISO flange and pump with CFF flange.

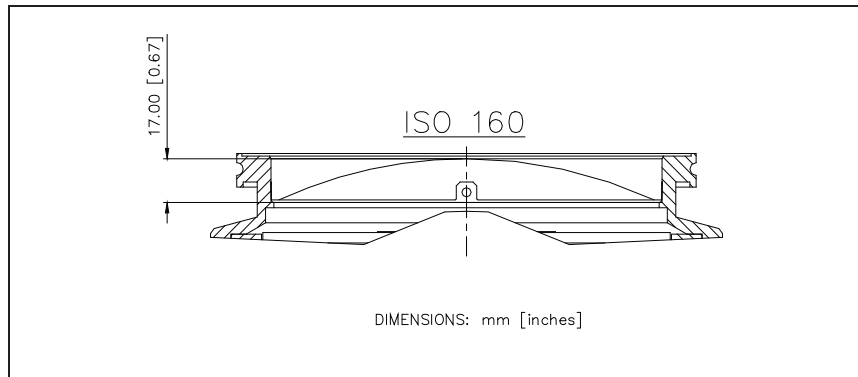

Figure 29

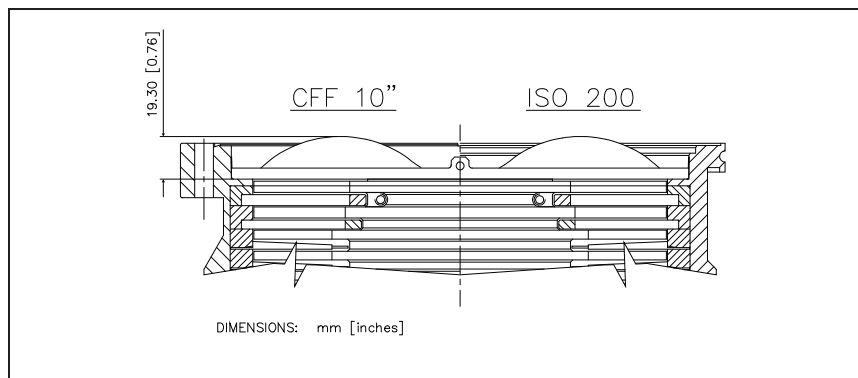

Figure 30

The following figure shows the ISO 250 pump flange section with the protection screen fitted on it. As you can see, the overall dimensions do not change as the inlet screen remains inside the pump profile.

17 Technical Information

Heater Band Installation

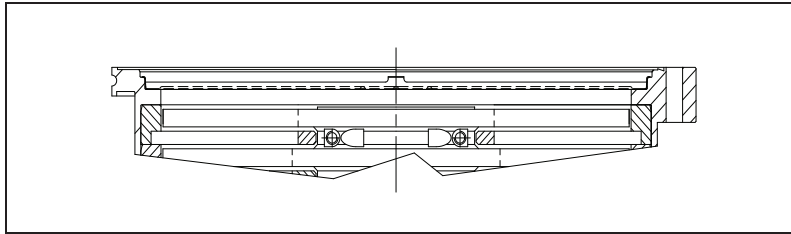

Figure 31

Heater Band Installation

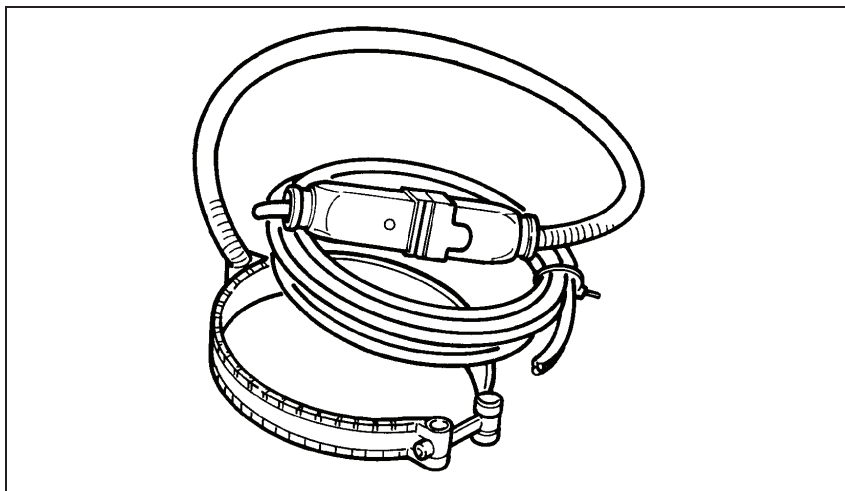

Figure 32

The heater band model 969-9317 and 969-9327 can be used to heat the pump casing when a bakeout is needed.

The heater band is available only for the pump with ConFlat inlet flange (model 969-8932). It is applied to the upper part of the pump casing, as shown in the figure, and heats it to a temperature of about 80° C.

The heater band must be mounted such that there is perfect thermal contact with the pump wall to obtain fast and efficient heating.

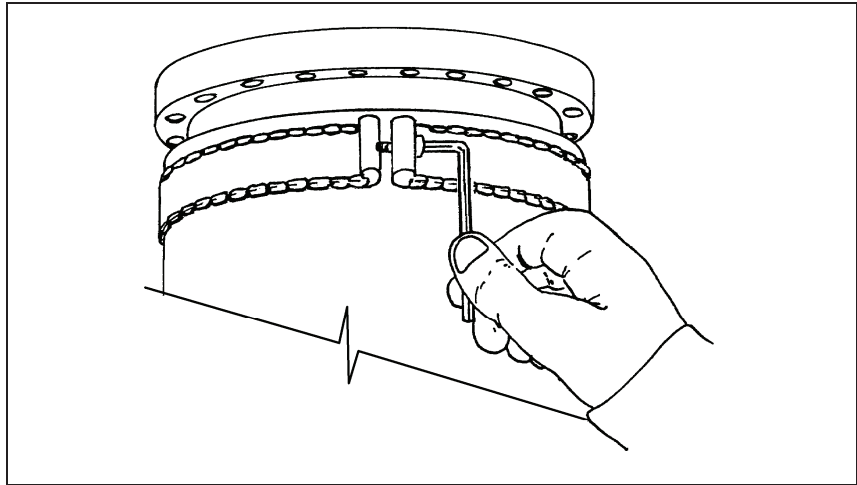

Figure 33

Switch on the heater while the turbopump is in operation. In the event of turbopump overheating, the pump will be automatically cut out by the thermistor sensor.

NOTE

The turbopump must be "baked" only when operating with an inlet pressure less than 10^{-4} mbar and with water cooling.

CAUTION!

If the chamber of the system is "baked" at a high temperature, a shield should be installed to prevent thermal radiation heating the high vacuum flange on the pump. The maximum temperature allowed for the inlet flange is 120° C.

Air Cooling Kit Installation

TV 1001 with Navigator Controller

An air cooling kit (mod. 969-9297) is available to improve the TV 1001 cooling during heavy operational conditions (optional).

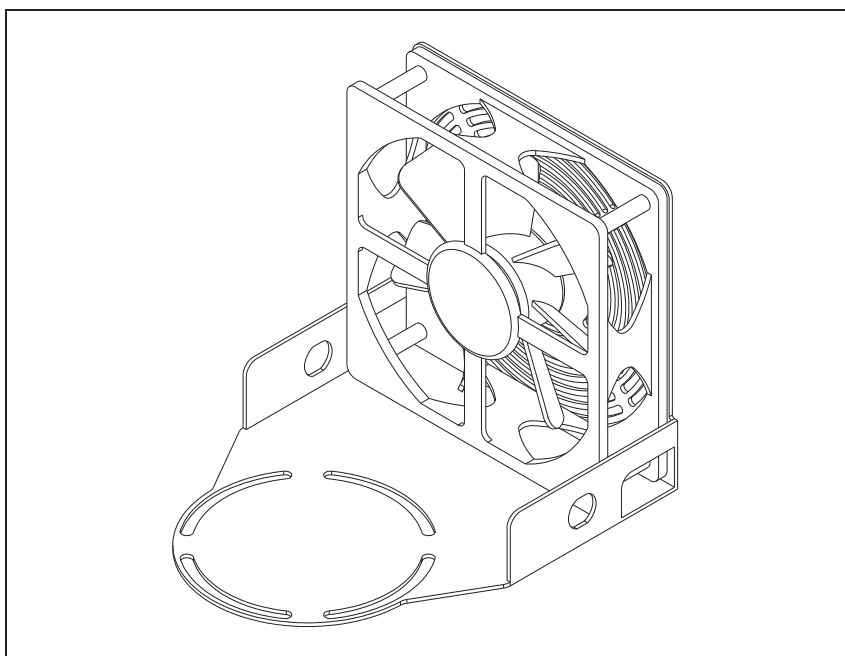

Figure 34

Fan specifications:

- air flow: 200m³/h
- input voltage: 24 Vdc
- dimensions: 127 x 127 x 38 mm (5 x 5 x 1.5 in.)
- power: 4.7 W

The fan bracket is shaped so that it can be mounted close to the pump.

To fix the fan to the TV 1001 case execute the following procedure (see the following figure):

- 1 Fix the fan to the suitable bracket by means of the furnished screws;
- 2 Fix the bracket to the pump body between the pump and the controller;
- 3 Connect the fan supply to the P4 connector of the controller.

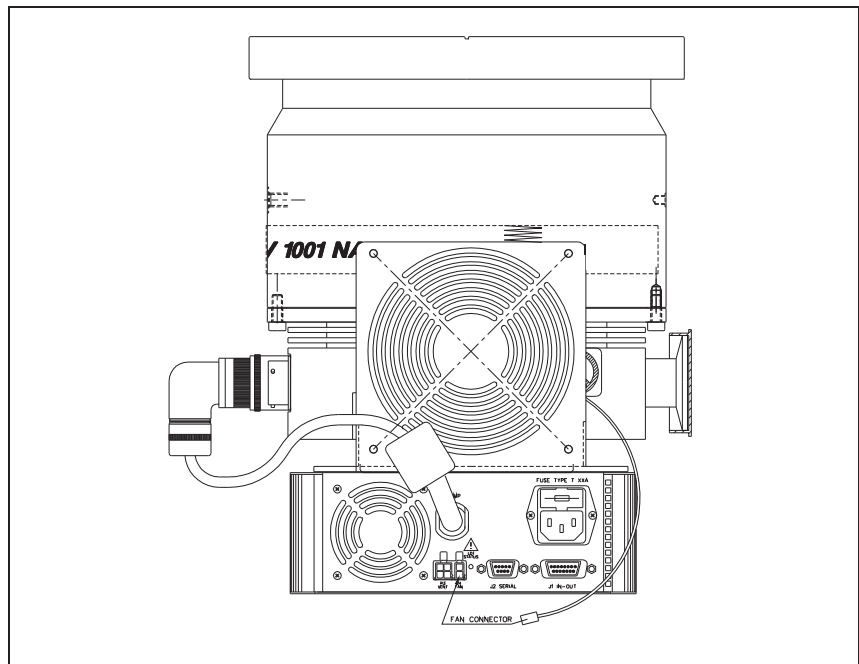

Figure 35

TV 1001 Pump with Standard Rack Controller

When the TV 1001 pumps are used with the standard rack controller, it is necessary to utilize the air cooling kit model 969-9315.

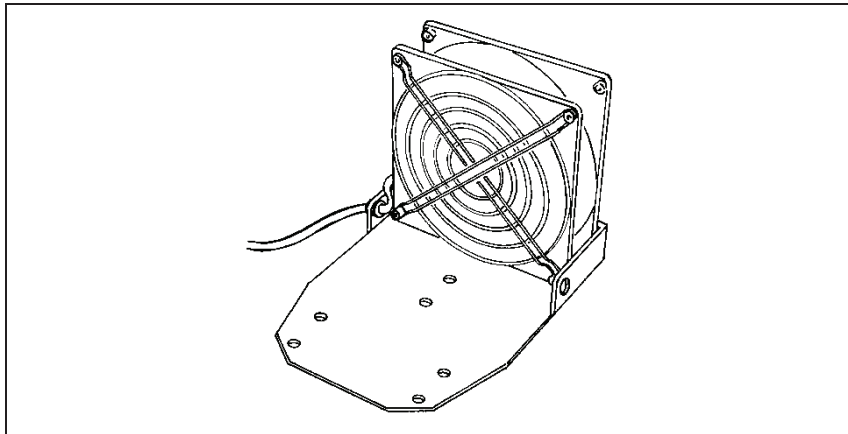

Figure 36

Fan specification:

- air flow: 55 l/s (120 CFM)
- input voltage: 120 Vac 50-60 Hz
- maximum power: 17 W
- dimensions: 127 x 127 mm (5 x 5 inches)

To fix the fan to the pump, position it ensuring that the holes in the plate line up with those in the pump base.

Insert the respective washers and screws and tighten with a screwdriver.

Connect the fan to the controller.

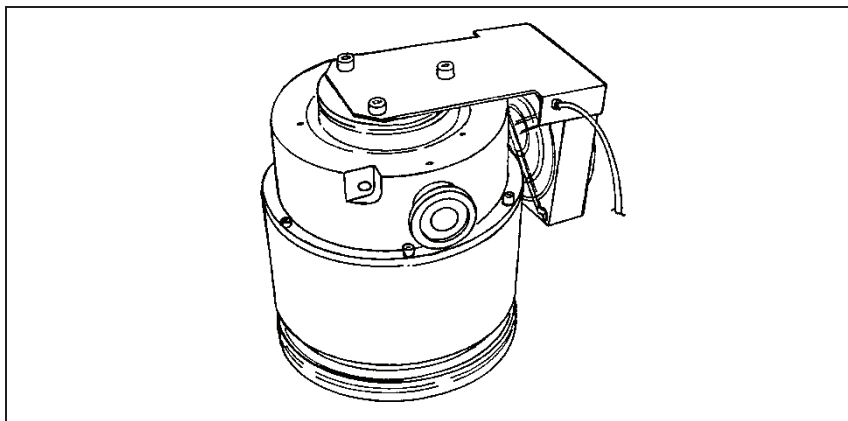

Figure 37

Water Cooling Kit Installation

Two types of water cooling kits are available to be mounted when the pump is used under heavy load conditions or when air cooling is insufficient.

The two model part numbers are: 969-9337 (metal-lic model), and 969-9347 (plastic model).

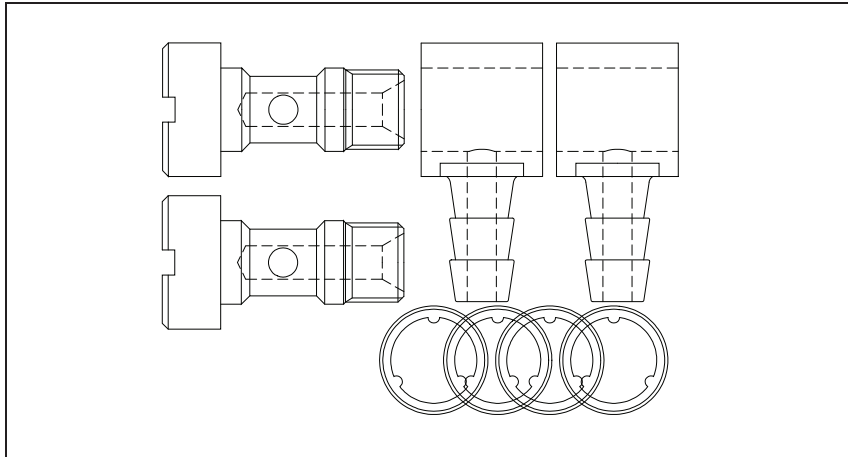

Figure 38 Model 969-9337

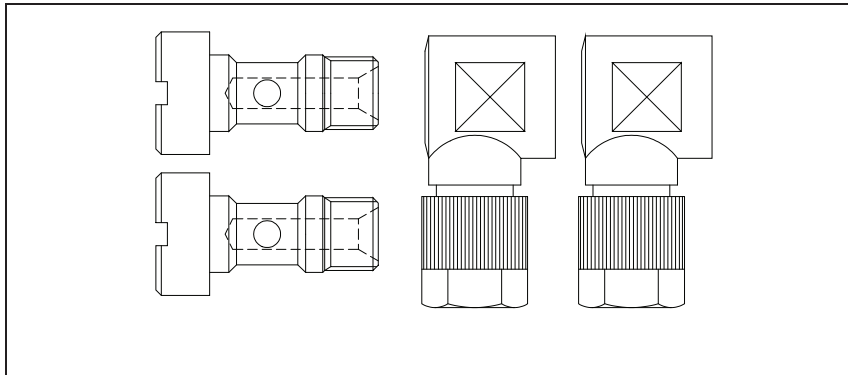

Figure 39 Model 969-9347

CAUTION!

The items of the plastic model kit must be assembled as shown in the following figure

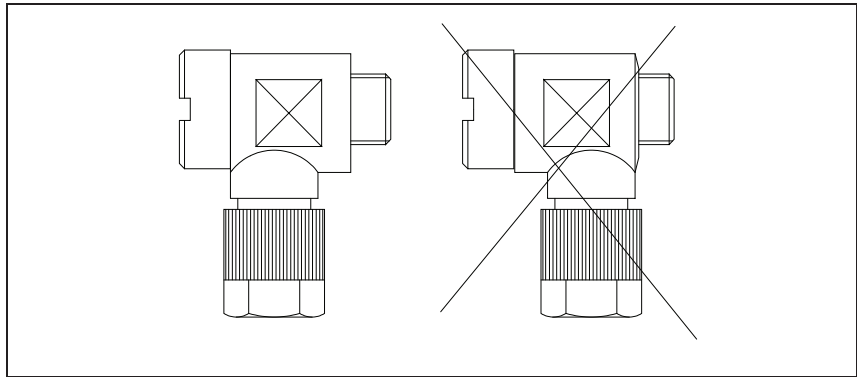

Figure 40

The assembled kit must be screwed into the suitable holes of the pump body with a recommended closing torque of 5 Nm.

17 Technical Information

Water Cooling Kit Installation

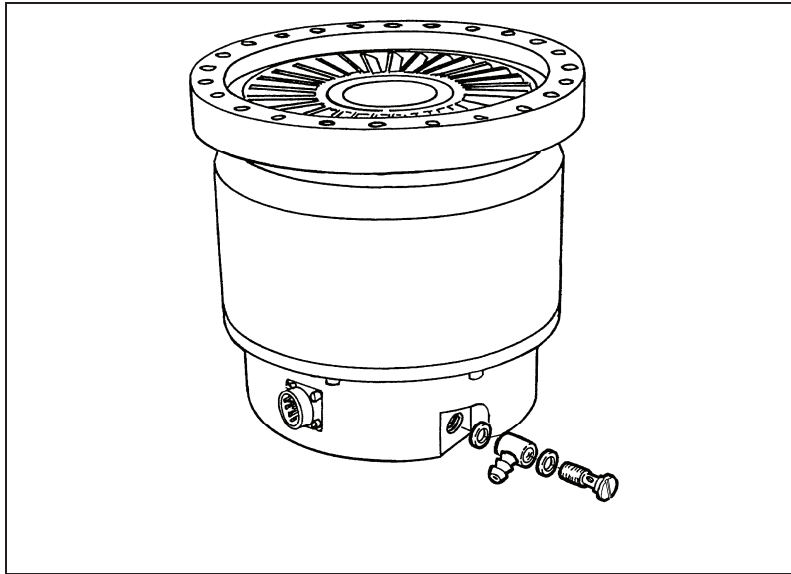

Figure 41

Two 6 mm (1/4") internal diameter rubber or plastic hoses from the water supply must be fitted to the two nozzles.

NOTE These hoses must be held on the respective nozzles using hose clips to avoid that the tube(s) gets loose or disconnected during operation.

Cooling may be carried out either through an open circuit with eventual discharge of the water, or using a closed circuit cooling system.

The water temperature must be between +10°C and +20°C, with an inlet pressure between 3 and 5 bar. This allows a flow of about 200 l/h.

NOTE The water electrical conductance must be $\leq 500 \mu\text{s}/\text{cm}$. When the conductance is higher, in closed water circuit, the use of up to 20 % of Ethyl-Glycole is suggested.

Vent Accessories

The vent valve and vent device allow to avoid undesired venting of the pump during temporary power failure and enables an automatic vent operation.

TV 1001 Navigator Controller Compatible Vent Valve mod. 969-9834

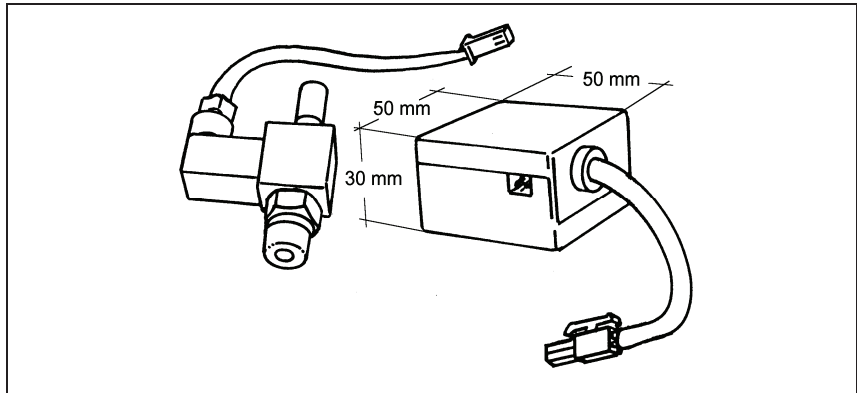

Figure 42

This vent valve waits before opening a minimum time of about 5 sec. This time can be increased up to about 220 min. by means of a setting of the Navigator software (optional).

17 Technical Information

Vent Accessories

To install the vent valve, unscrew the threaded plug (see figure below).

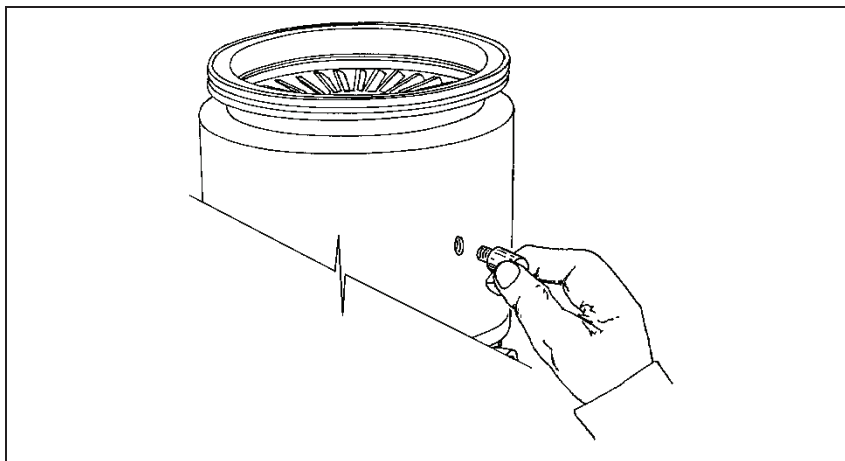

Figure 43

Then screw the vent valve into the pump and tight-en it using a 16 mm hexagonal spanner with a torque of 2.5 Nm.

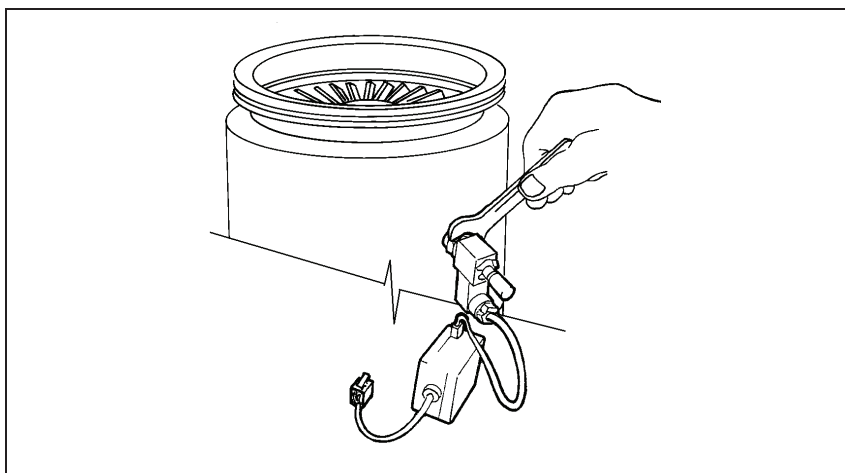

Figure 44

CAUTION! Do not overtighten the valve as this may damage the thread on the pump.

Then connect the cable from the valve to the suitable connector on the controller (see the preceding paragraph “INTERCONNECTIONS”).

Standard Rack Controller Compatible Vent Valve mod. 969-9843

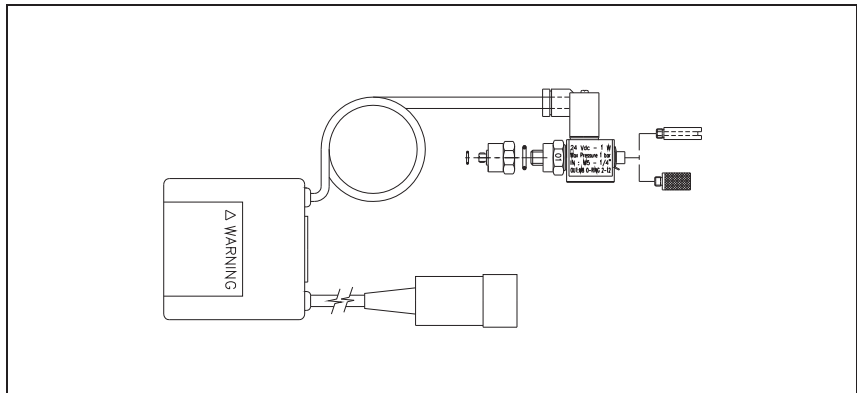

Figure 45

This vent valve has a fixed delay time of about 5 sec. This value can be used only with rack controller.

To install the vent valve execute the same steps as the vent valve model 969-9834 (see the above paragraph).

Vent Device mod. 969-9831

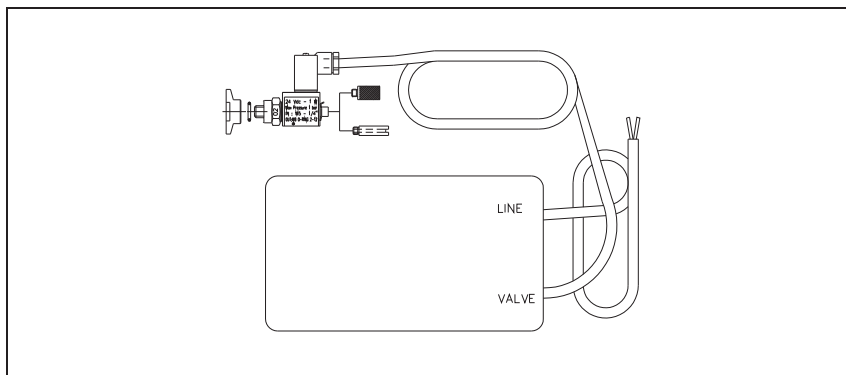

Figure 46

The vent device has adjustable delay time (up to 36 min.). This value can be used only with rack controller. To install the vent device unscrew and remove the threaded plug (see figure below).

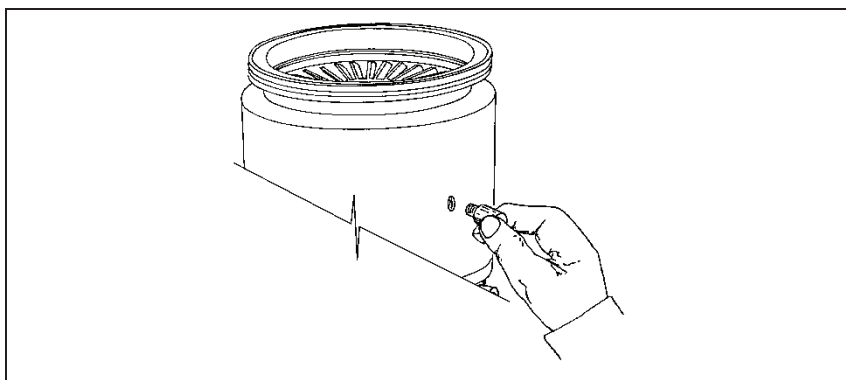

Figure 47

Screw the flange mod. 969-9108 on the pump, taking care of the o-ring right position.

Assemble the seal ring and lock the vent device in position using the KF klamp.

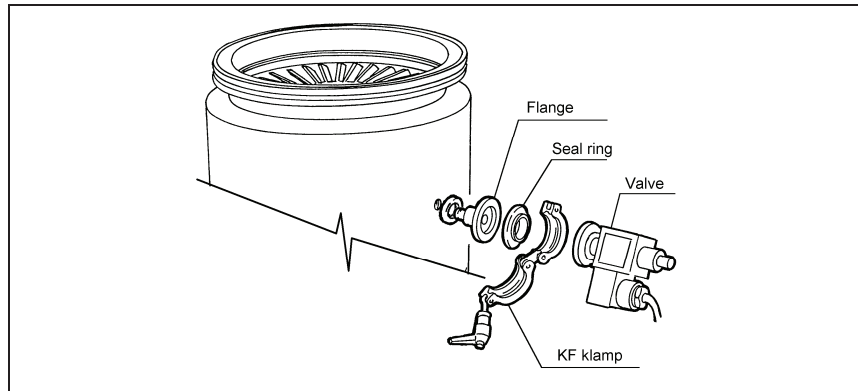

Figure 48

Vibration Isolator Installation

Three vibration isolators for ISO and CFF inlet flange version pumps are available as accessories.

The three model part numbers are the following:

- model 969-9345 for ISO 160 flange;
- model 969-9346 for ISO 200 flange;
- model 969-9336 for CFF 10" flange.

They typically reduce the vibration transmitted from the TV 1001 Navigator to the system by a factor of 20.

Please refer to the relevant instruction manual.

Purge Valve Installation

A gas purge valve is available to protect the pump bearings against particulate and corrosive gases that could move into the pump.

To install the gas purge valve it is necessary to unscrew the purge port cover as shown in the following figure,

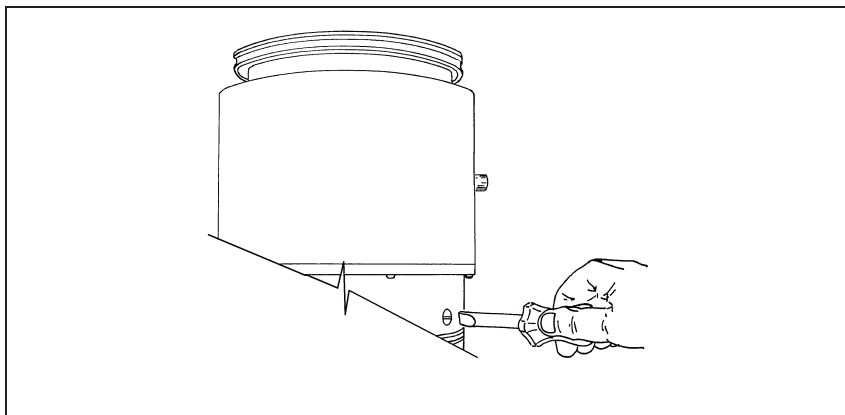

Figure 49

and then screw the gas purge valve (with a torque of 2.5 Nm) as shown in the following figure.

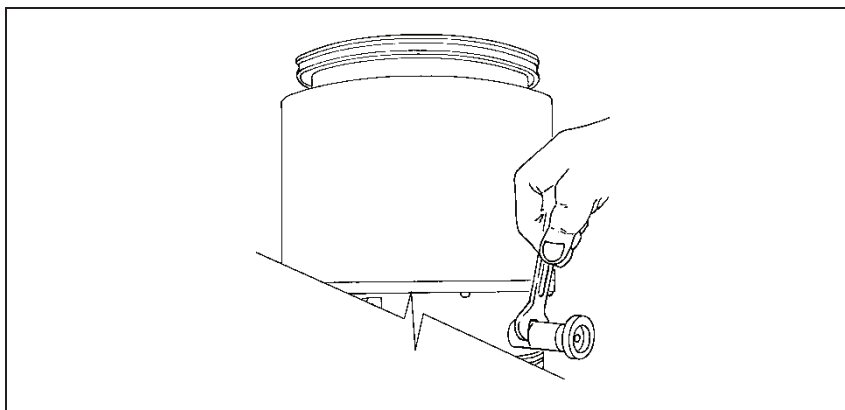

Figure 50

Serial Cable Installation

The supplied serial cable must be installed when the TV 1001 Navigator or the optional vent valve have to be controlled by means of a remote computer.

The cable is installed fixing the 9 pin D-type connector into the P2 serial connector as shown in the following figure.

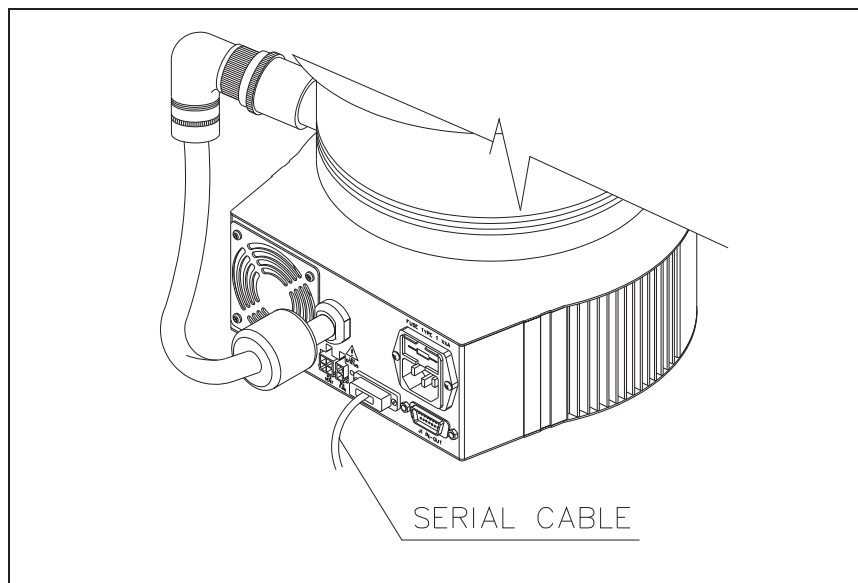

Figure 51

TV 1001 Controller Installation

The controller can be mounted in two position:

- bottom mounting (as per the complete system)
- side mounting.

To install the controller execute the following procedures.

Bottom Mounting

See the following figure.

- 1** Turn the pump upside-down;
- 2** Place the three fixing blocks with the through holes toward the inside, and fix them with the three M6 screws to the pump bottom;
- 3** Place the controller on the blocks, with the pump cable toward the pump body;
- 4** Fix the controller to the blocks by means of the three socket head screws M5;
- 5** Turn the pump again;
- 6** Plug the line card and connect the pump cable to the pump;
- 7** Connect the mating connector with the jumper on the interlock signal to start the pump.

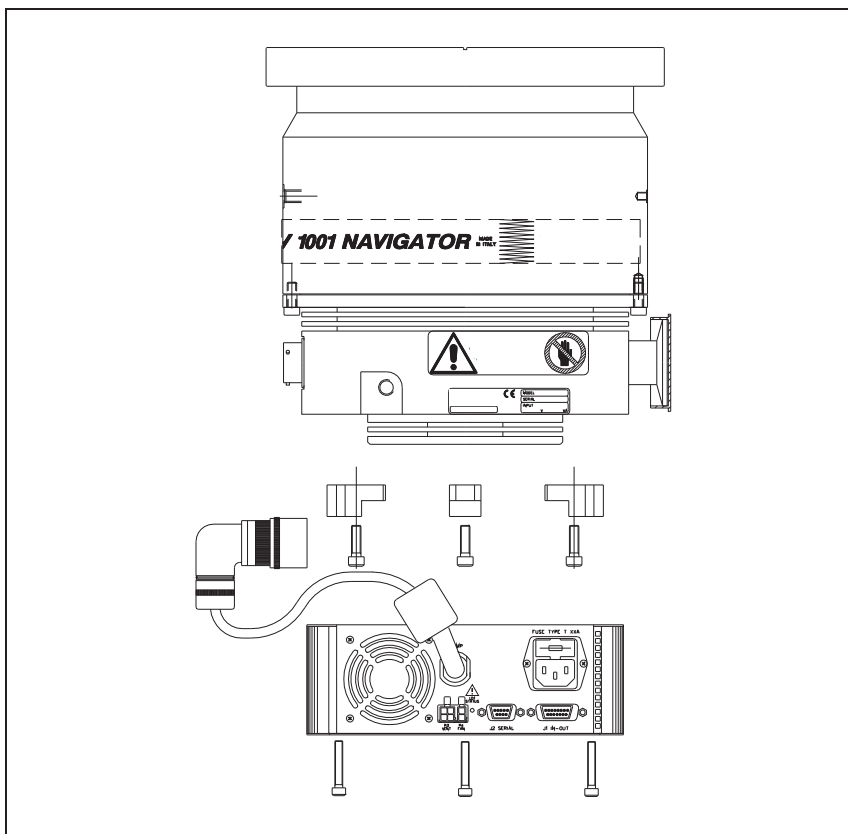

Figure 52

Side Mounting

NOTE The L-shaped bracket (P/N 969-9298) is available as an option.

See the following figure.

- 1** Place the L-shaped bracket on the controller, with the pump cable toward the bracket, and fix it by means of the three socket head screws M5, the washers and the nuts. The 6 holes on the bracket allows to mount the controller with the rotation angle that you like;
- 2** Turn the pump upside-down;
- 3** Place the bracket on the pump bottom (the hole on the bracket has the same diameter as the pump bottom flange);
- 4** Screw a little bit the three screws M6 in the holes on the pump bottom;
- 5** Rotate the bracket until the controller is on the chosen position;
- 6** Tighten the screws properly;
- 7** Turn the pump again;
- 8** Plug the line card and connect the pump cable to the pump;
- 9** Connect the mating connector with the jumper on the interlock signal to start the pump.

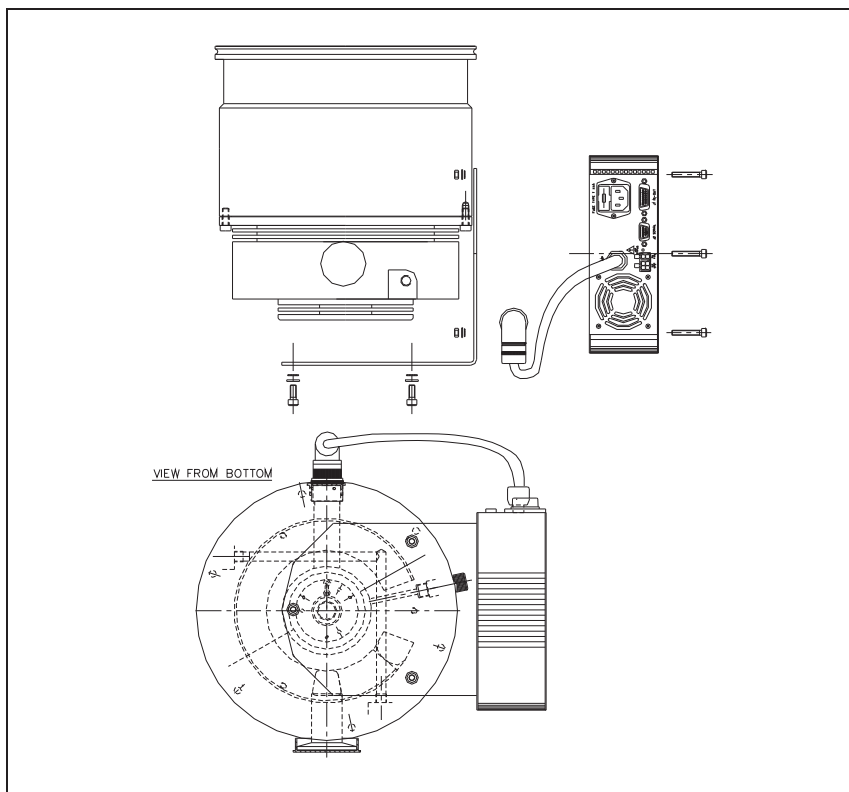

Figure 53

Connection A - High Vacuum Flange

For ISO-K flange connections, fix the two flanges with the clamps as shown in the figure.

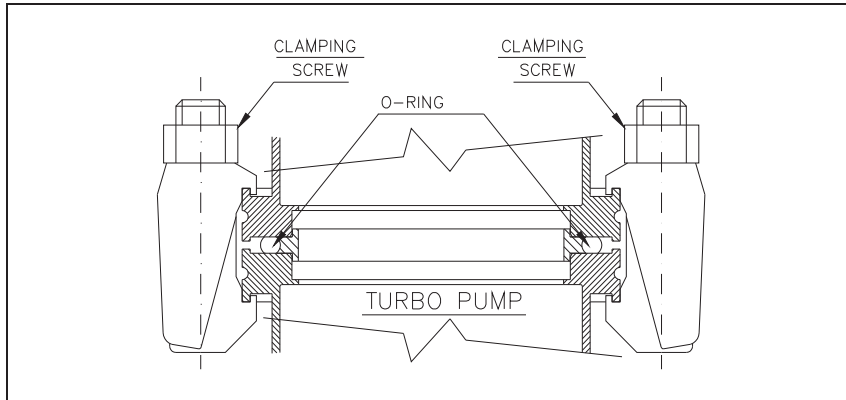

Figure 54

WARNING!



It is mandatory to connect the pump in such a way to withstand the torque specified in the "IN-STRUCTION FOR USE" section. Specifically pay attention to clamp design, material of clamps and bolts and bolt fixing torque

For ConFlat flange connections we recommend using Agilent hardware.

To facilitate assembly and dismantling, apply Fel-pro C-100 high temperature lubricant to the screw threads protruding from the flange and between the nuts and flange.

Note that the connections can be made only with the bolt in the lower side.

Attach the units and tighten each one in turn. Re-repeat the sequential tightening until the flange faces meet.

CAUTION! Exercise care when tightening nuts and bolts to avoid creating dents in the envelope as this may cause the pump rotor to lock.

Connection Configurations

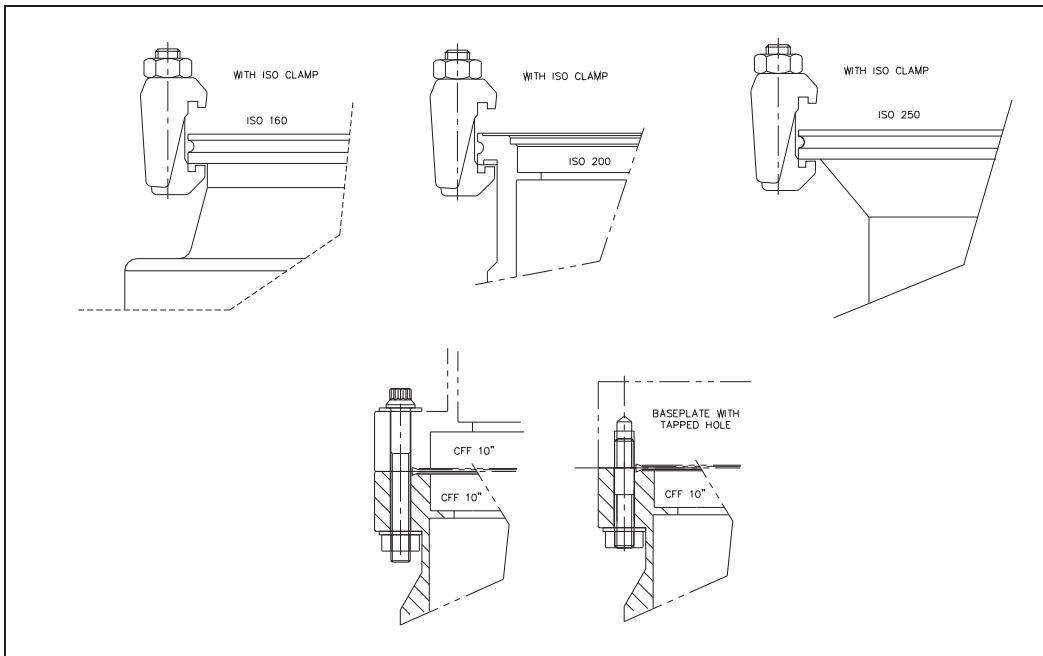

Figure 55

Connection B - Fore-Vacuum Pump

A flange KF 40 NW is available to connect the Turbo V1001 pump to the fore-vacuum pump. A hose or vacuum approved pipe can be used. If a rigid pipe is used, any vibration generated by the mechanical pump must be eliminated through the use of bellows.

NOTE The Turbo V1001 pump is characterized by its high compression ratio also for oil vapors. When using a mechanical oil-sealed pump, it is advisable to in-stall a suitable trap between the turbopump and the fore-vacuum pump in order to prevent oil back-streaming.

Connection C – Electrical

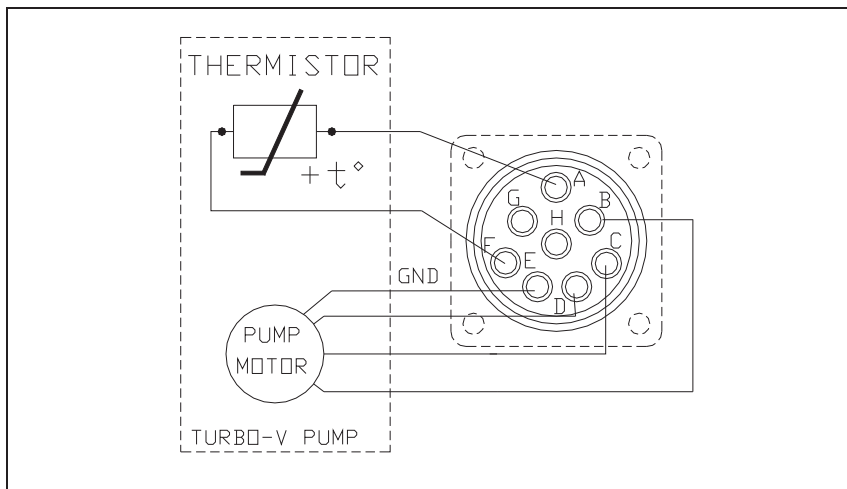

Figure 56

The turbopump is connected to the controller through an 8-pin connector. Pins B, C and D are the 3-phase supply to the motor, pins A and F are connected to the temperature sensor (NTC type, 30 K Ω resistance at 25° C) and pin E is connected to the pump ground; pins G and H are not connected.

If the temperature sensor is disconnected, the pump will not start. To prevent damage to the pump when the temperature exceeds 60° C, the sensor automatically cuts out the power supply.

Pump Used with Corrosive Gases

To prevent damage to the bearings, an inert gas must flow into the pump body around the upper bearing towards the forevacuum line. To supply the inert purge gas (e. g. nitrogen) to the pump through the purge port, connect a gas purge valve between the pressure regulator and the pump.

Adjust the pressure regulator in order to read a gas flow rate of 0.1 to 0.8 mbar l/s.

CAUTION!

To prevent bearing damage, Agilent suggests a minimum purge gas flow rate of 10 sccm (0.17 mbar l/s). This value can be exceeded, according to the process requirements. Please contact Agilent for specific applications.

The purge gas throughput with the recommended forepump of 15 m³/h (11 CFM) allows to achieve a high vacuum pressure in the 10⁻⁸ mbar range.

The recommended gas flow maintains a pressure into the pump body higher than the forevacuum pressure.

The recommended procedure to vent the system and the pump avoiding the contact between the pump bearings and the corrosive gas is described in the following points:

- 1 Close the corrosive gas flow into the system.
- 2 Leaving the Turbo-V pump and the backing pump running and the purge gas flowing, wait for enough time to evacuate the corrosive gas from the system.
- 3 Turn off the Turbopump.
- 4 Open the Turbo-V vent port slowly until to reach atmospheric pressure in the system.
- 5 When the Turbo-V pump and the backing pump are stopped and the system is at atmospheric pressure, for a better bearing protection it is advisable to leave the purge gas flowing into the Turbo-V pump, with the chamber or the Turbo-V vent valve opened, to avoid system overpressures. If the vent valve can't be kept opened, the backing pump should be left operating.

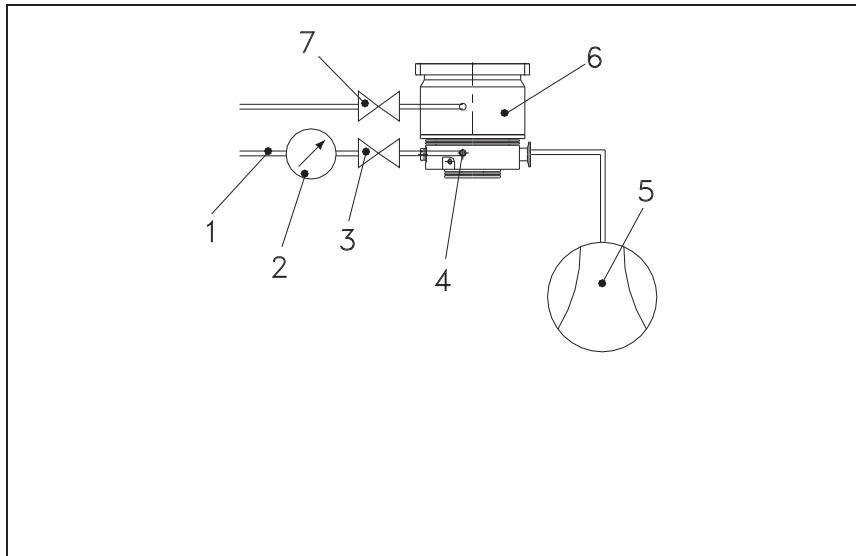

Figure 57 Purge layout

1	Purge gas line
2	Pressure regulator
3	Gas purge valve
4	Gas purge port
5	Forevacuum pump
6	Turbopump
7	Vent valve

Pump Used in Presence of Magnetic Fields

Magnetic fields induce eddy currents in the rotor of a turbomolecular pump that tend to oppose to its rotation.

The result is increased electrical power consumption by the motor, most of which is dissipated in the rotor.

Since the rotor is not in contact with the stator the above power can leave the rotor mainly by radiation and hence the rotor may be overheated while static parts of the pump remain cool.

This effect is strongly dependant from the intensity, time function and distribution of the magnetic field.

In general, therefore, an increase in pump current can be expected.

If this increase is lower than 50 % of the current value drawn by the motor in high vacuum operation, no particular problem should be expected.

However if the effect is grater, than the case should be carefully reviewed by Agilent's specialist. As a matter of fact, in case of high magnetic fields, also important forces might be generated and applied to the rotor.

Accessories and Spare Parts

Tab. 9

Description	Part number
Mains cable NEMA Plug, 3m long	969-9958
Mains cable European Plug, 3m long	969-9957
Serial cable and Navigator Software	969-9883
Bracket for controller side mounting	969-9298
Inlet screen ISO 160	969-9304
Inlet screen ISO 200 and CFF 10"	969-9316
Inlet screen ISO 250	969-9350
Heater band, 220 V	969-9327
Heater band, 120 V	969-9317
Water cooling kit (plastic model)	969-9347
Water cooling kit (metallic model)	969-9337
Air cooling kit for Navigator Controller	969-9297
Air cooling kit for standard rack controller	969-9315
Vibration isolator, ISO 160	969-9345
Vibration isolator, ISO 200	969-9346
Vibration isolator, CF 10"	969-9336
Vent flange, NW 10 KF / M8	969-9108
Vent device with adjustable delay time for standard rack controller	969-9831
Vent valve for standard rack controller	969-9843
Vent valve for Navigator Controller	969-9834
Purge valve with KF16 flange	969-9239
Purge valve with 7/16" flange	969-9240
Purge valve KF16-M12 20 SCCM	969-9241
Purge valve 7/16-M12 20 SCCM	969-9242
Forepump DS 402, with 1 ph. / 3 ph., universal motor	949-9382
Triscroll Dry Vacuum Pump PTS 300 single phase, universal motor	PTS03001UNIV
Triscroll Dry Vacuum Pump PTS 300 3 phase, universal motor	PTS03003UNIV

17 Technical Information
Accessories and Spare Parts



Agilent Technologies

Vacuum Products Division

Dear Customer,

Thank you for purchasing an Agilent vacuum product. At Agilent Vacuum Products Division we make every effort to ensure that you will be satisfied with the product and/or service you have purchased.

As part of our Continuous Improvement effort, we ask that you report to us any problem you may have had with the purchase or operation of our products. On the back side you find a Corrective Action request form that you may fill out in the first part and return to us.

This form is intended to supplement normal lines of communications and to resolve problems that existing systems are not addressing in an adequate or timely manner.

Upon receipt of your Corrective Action Request we will determine the Root Cause of the problem and take the necessary actions to eliminate it. You will be contacted by one of our employees who will review the problem with you and update you, with the second part of the same form, on our actions.

Your business is very important to us. Please, take the time and let us know how we can improve.

Sincerely,

Giampaolo LEVI

***Vice President and General Manager
Agilent Vacuum Products Division***

Note: Fax or mail the Customer Request for Action (see backside page) to Agilent Vacuum Products Division (Torino) – Quality Assurance or to your nearest Agilent representative for onward transmission to the same address.

CUSTOMER REQUEST FOR CORRECTIVE / PREVENTIVE / IMPROVEMENT ACTION

TO: AGILENT VACUUM PRODUCTS DIVISION TORINO – QUALITY ASSURANCE

FAX N°: XXXX-011-9979350

ADDRESS: AGILENT TECHNOLOGIES ITALIA S.p.A. – Vacuum Products Division –
Via F.lli Varian, 54 – 10040 Leinì (TO) – Italy

E-MAIL: vpd-qualityassurance_pdl-ext@agilent.com

NAME _____	COMPANY _____	FUNCTION _____
ADDRESS: _____		
TEL. N° : _____ FAX N° : _____		
E-MAIL: _____		
PROBLEM / SUGGESTION : _____ _____ _____ _____		
REFERENCE INFORMATION (model n°, serial n°, ordering information, time to failure after installation, etc.): _____ _____ _____ DATE _____		
CORRECTIVE ACTION PLAN / ACTUATION (by AGILENT VPD) _____ _____ _____ _____ _____		LOG N° _____

XXX = Code for dialing Italy from your country (es. 01139 from USA; 00139 from Japan, etc.)





**Vacuum Products Division
Instructions for returning products**

Dear Customer:

Please follow these instructions whenever one of our products needs to be returned.

- 1) Complete the attached Request for Return form and send it to Agilent Technologies (see below), taking particular care to identify all products that have pumped or been exposed to any toxic or hazardous materials.
- 2) After evaluating the information, Agilent Technologies will provide you with a Return Authorization (RA) number via email or fax, as requested.
Note: Depending on the type of return, a Purchase Order may be required at the time the Request for Return is submitted. We will quote any necessary services (evaluation, repair, special cleaning, eg).
- 3) **Important steps for the shipment of returning product:**
 - Remove all accessories from the core product (e.g. inlet screens, vent valves).
 - Prior to shipment, drain any oils or other liquids, purge or flush all gasses, and wipe off any excess residue.
 - If ordering an Advance Exchange product, please use the packaging from the Advance Exchange to return the defective product.
 - Seal the product in a plastic bag, and package product carefully to avoid damage in transit. You are responsible for loss or damage in transit.
 - Agilent Technologies is not responsible for returning customer provided packaging or containers.
 - **Clearly label package with RA number.** Using the shipping label provided will ensure the proper address and RA number are on the package. Packages shipped to Agilent without a RA clearly written on the outside cannot be accepted and will be returned.
- 4) Return only products for which the RA was issued.
- 5) **Product being returned under a RA must be received within 15 business days.**
- 6) **Ship to the location specified on the printable label, which will be sent, along with the RA number, as soon as we have received all of the required information.** Customer is responsible for freight charges on returning product.
- 7) Return shipments must comply with all applicable **Shipping Regulations** (IATA, DOT, etc.) and carrier requirements.

RETURN THE COMPLETED REQUEST FOR RETURN FORM TO YOUR NEAREST LOCATION:

EUROPE:	NORTH AMERICA:	PACIFIC RIM:
Fax: 00 39 011 9979 330 Fax Free: 00 800 345 345 00 Toll Free: 00 800 234 234 00 vpt-customer@agilent.com	Fax: 1 781 860 9252 Toll Free: 800 882 7426, Option 3 vpl-ra@agilent.com	please visit our website for individual office information http://www.agilent.com



Please read important policy information on Page 3 that applies to all returns.

1) CUSTOMER INFORMATION

Form with fields: Company Name, Contact Name, Tel, Email, Fax, Customer Ship To, Customer Bill To, Europe only: VAT reg. Number, USA/Canada only: Taxable, Non-taxable

2) PRODUCT IDENTIFICATION

Table with 4 columns: Product Description, Agilent P/N, Agilent S/N, Original Purchasing Reference

3) TYPE OF RETURN (Choose one from each row and supply Purchase Order if requesting a billable service)

- 3A. Non-Billable, Billable, New PO # (hard copy must be submitted with this form);
3B. Exchange, Repair, Upgrade, Consignment/Demo, Calibration, Evaluation, Return for Credit

4) HEALTH and SAFETY CERTIFICATION

AGILENT TECHNOLOGIES CANNOT ACCEPT ANY PRODUCTS CONTAMINATED WITH BIOLOGICAL OR EXPLOSIVE HAZARDS, RADIOACTIVE MATERIAL, OR MERCURY AT ITS FACILITY. Call Agilent Technologies to discuss alternatives if this requirement presents a problem. The equipment listed above (check one): HAS NOT pumped or been exposed to any toxic or hazardous materials. OR HAS pumped or been exposed to the following toxic or hazardous materials. List all toxic/hazardous materials. Include product name, chemical name, and chemical symbol or formula.

5) FAILURE INFORMATION:

Failure Mode (REQUIRED FIELD. See next page for suggestions of failure terms); Detailed Description of Malfunction: (Please provide the error message); Application (system and model):

I understand and agree to the terms of Section 6, Page 3/3. Print Name: Authorized Signature: Date:



Please use these Failure Mode to describe the concern about the product on Page 2.

TURBO PUMPS and TURBO CONTROLLERS

APPARENT DEFECT/MALFUNCTION	POSITION	PARAMETERS
- Does not start - Does not spin freely - Does not reach full speed - Mechanical Contact - Cooling defective	- Noise - Vibrations - Leak - Overtemperature - Clogging	- Vertical - Horizontal - Upside-down - Other:
		Power: Rotational Speed: Current: Inlet Pressure: Temp 1: Foreline Pressure: Temp 2: Purge flow: OPERATING TIME:

ION PUMPS/CONTROLLERS

- Bad feedthrough	- Poor vacuum
- Vacuum leak	- High voltage problem
- Error code on display	- Other

VALVES/COMPONENTS

- Main seal leak	- Bellows leak
- Solenoid failure	- Damaged flange
- Damaged sealing area	- Other

LEAK DETECTORS

- Cannot calibrate	- No zero/high background
- Vacuum system unstable	- Cannot reach test mode
- Failed to start	- Other

INSTRUMENTS

- Gauge tube not working	- Display problem
- Communication failure	- Degas not working
- Error code on display	- Other

SCROLL AND ROTARY VANE PUMPS

- Pump doesn't start	- Noisy pump (describe)
- Doesn't reach vacuum	- Over temperature
- Pump seized	- Other

DIFFUSION PUMPS

- Heater failure	- Electrical problem
- Doesn't reach vacuum	- Cooling coil damage
- Vacuum leak	- Other

Section 6) **ADDITIONAL TERMS**

Please read the terms and conditions below as they apply to all returns and are in addition to the Agilent Technologies Vacuum Product Division – Products and Services Terms of Sale.

- Customer is responsible for the freight charges for the returning product. Return shipments must comply with all applicable **Shipping Regulations** (IATA, DOT, etc.) and carrier requirements.
- Customers receiving an Advance Exchange product agree to return the defective, rebuildable part to Agilent Technologies **within 15 business days**. Failure to do so, or returning a non-rebuildable part (crashed), will result in an invoice for the non-returned/non-rebuildable part.
- Returns for credit toward the purchase of new or refurbished Products are subject to prior Agilent approval and may incur a restocking fee. Please reference the original purchase order number.
- Units returned for evaluation will be evaluated, and a quote for repair will be issued. If you choose to have the unit repaired, the cost of the evaluation will be deducted from the final repair pricing. A Purchase Order for the final repair price should be issued within 3 weeks of quotation date. Units without a Purchase Order for repair will be returned to the customer, and the evaluation fee will be invoiced.
- A Special Cleaning fee will apply to all exposed products per Section 4 of this document.
- If requesting a calibration service, units must be functionally capable of being calibrated.

Sales and Service Offices

United States

**Agilent Technologies
Vacuum Products Division**
121 Hartwell Avenue
Lexington, MA 02421 - USA
Tel.: +1 781 861 7200
Fax: +1 781 860 5437
Toll-Free: +1 800 882 7426

Benelux

**Agilent Technologies Netherlands B.V.
Vacuum Products Division**
Herculesweg 8
4338 PL Middelburg
The Netherlands
Tel.: +31 118 671570
Fax: +31 118 671569
Toll-Free: 00 800 234 234 00

Canada

**Central coordination through: Agilent Technologies
Vacuum Products Division**
121 Hartwell Avenue
Lexington, MA 02421 - USA
Tel.: +1 781 861 7200
Fax: +1 781 860 5437
Toll-Free: +1 800 882 7426

China

**Agilent Technologies (China) Co. Ltd
Vacuum Products Division**
No.3, Wang Jing Bei Lu,
Chao Yang District,
Beijing, 100102
China
Tel.: +86 (10) 6439 7718
Toll-Free: 800 820 6556

France

**Agilent Technologies France
Vacuum Products Division**
7 Avenue des Tropiques
Z.A. de Courtaboeuf - B.P. 12
91941 Les Ulis cedex - France
Tel.: +33 (0) 1 69 86 38 84
Fax: +33 (0) 1 69 86 29 88
Toll free: 00 800 234 234 00

Germany and Austria

**Agilent Technologies
Vacuum Products Division**
Alsfelder Strasse 6 Postfach 11
14 35
64289 Darmstadt – Germany
Tel.: +49 (0) 6151 703 353
Fax: +49 (0) 6151 703 302
Toll free: 00 800 234 234 00

India

**Agilent Technologies India Pvt. Ltd.
Vacuum Product Division**
G01. Prime corporate Park,
230/231, Sahar Road, Opp. Blue Dart Centre,
Andheri (East), Mumbai – 400 099.India
Tel: +91 22 30648287/8200
Fax: +91 22 30648250
Toll Free: 1800 113037

Italy

**Agilent Technologies Italia S.p.A.
Vacuum Products Division**
Via F.lli Varian 54
10040 Leini, (Torino) - Italy
Tel.: +39 011 997 9111 Fax: +39 011 997 9350
Toll-Free: 00 800 234 234 00

Japan

**Agilent Technologies Japan, Ltd.
Vacuum Products Division**
8th Floor Sumitomo Shibaura Building
4-16-36 Shibaura Minato-ku Tokyo 108-0023 - Japan
Tel.: +81 3 5232 1253
Fax: +81 3 5232 1710
Toll-Free: 0120 655 040

Korea

**Agilent Technologies Korea, Ltd.
Vacuum Products Division**
Shinsa 2nd Bldg. 2F 966-5 Daechi-dong
Kangnam-gu, Seoul
Korea 135-280
Tel.: +82 2 3452 2452
Fax: +82 2 3452 2451
Toll-Free: 080 222 2452

Mexico

**Agilent Technologies
Vacuum Products Division**
Concepcion Beistegui No 109 Col Del Valle
C.P. 03100 – Mexico, D.F.
Tel.: +52 5 523 9465
Fax: +52 5 523 9472

Singapore

**Agilent Technologies Singapore Pte. Ltd,
Vacuum Products Division**
Agilent Technologies Building,
1 Yishun Avenue 7,
Singapore 768923
Tel : (65) 6215 8045
Fax : (65) 6754 0574

Southeast Asia

**Agilent Technologies Sales Sdn Bhd
Vacuum Products Division**
Unit 201, Level 2 uptown 2,
2 Jalan SS21/37, Damansara Uptown
47400 Petaling Jaya,
Selangor, Malaysia
Tel : +603 7712 6106
Fax: +603 6733 8121

Taiwan

**Agilent Technologies Taiwan Limited
Vacuum Products Division (3F)**
20 Kao-Shuang Rd.,
Pin-Chen City, 324
Taoyuan Hsien , Taiwan, R.O.C.
Tel. +886 34959281
Toll Free: 0800 051 342

UK and Ireland

**Agilent Technologies UK, Ltd.
Vacuum Products Division**
6 Mead Road Oxford Industrial Park
Yarnton, Oxford OX5 1QU – UK
Tel.: +44 (0) 1865 291570
Fax: +44 (0) 1865 291571
Toll free: 00 800 234 234 00

Other Countries

**Agilent Technologies Italia S.p.A.
Vacuum Products Division**
Via F.lli Varian 54 10040 Leini, (Torino) -
Italy
Tel.: +39 011 997 9111
Fax: +39 011 997 9350
Toll-Free: 00 800 234 234 00

Customer Support & Service

NORTH AMERICA:

Toll Free: 800 882 7426, Option 3
vpl-ra@agilent.com

EUROPE:

Toll Free: 00 800 234 234 00
vpt-customer@agilent.com

PACIFIC RIM:

please visit our website for individual office
information <http://www.agilent.com>

Worldwide Web Site, Catalog and Order On-line:

www.agilent.com
Representative in most countries
12/10

© Agilent Technologies, Inc. 2011

Printed in ITALY
04/2011
Publication Number: 87-901-945-01 (I)



Agilent Technologies